

Installation and Servicing Instructions

ICS1



Wall mounted condensing boiler for central heating



6 720 610 598-00.10

ZSBR 7-28 ICS1 GC-Number: 41 108 04



6 720 610 603 GB (03.02) OSW



Contents

Safety precautions	3	6.5.3 Manual operating mode (if TR2 is not connected)	29
Symbols	3	6.6 Hot water	29
1 Details of the appliance	4	6.6.1 Hot water programme	29
1.1 EC Declaration of Conformity	4	6.6.2 Hot water immediately	29
1.2 Standard package	4	6.7 i Info	29
1.3 Description of appliance	4	6.8 Settings	30
1.4 Accessories	5	6.8.1 Heating (if TR 2 is connected)	30
1.5 Casing dimensions	5	6.8.2 Hot Water (Storage Tank, ZSBR models only)	30
1.6 Layout of appliance	6	6.8.3 Service	30
1.7 Function	7	6.9 Individual timer programmes	30
1.8 Electrical wiring diagram	8		
1.9 Technical data	9		
2 Installation regulations	10	7 Individual settings	31
3 Installation	11	7.1 Mechanical settings	31
3.1 Important remarks	11	7.1.1 Checking the size of the expansion vessel	31
3.2 Sealed systems	11	7.1.2 Setting the central heating flow temperature	31
3.3 Siting the appliance	13	7.2 Settings on the Bosch Heatronic	31
3.4 Wall mounting frame assembly	14	7.2.1 General description	31
3.5 Pre-piping the system	14	7.2.2 Setting the anti-cycle time (Service Function 2.4)	32
3.6 Fitting the appliance	15	7.2.3 Setting the maximum CH flow temperature (Service Function 2.5)	32
3.7 Checking the connections	16	7.2.4 Setting the heating output (Service Function 5.0)	32
3.8 Flue Systems	16	7.2.5 Variable pump settings (Service Function 7.0)	32
3.8.1 Siting the Flue Terminal	17	7.3 Setting the gas/air ratio	32
3.8.2 Installation of the flue	18		
3.8.3 Flue duct preparation and assembly	20	8 Converting the appliance to different gas types	33
4 Electrical connections	21	8.1 Setting the gas/air ratio	33
4.1 Connecting the appliance	21	8.2 Testing combustion air/flue gas at set heat output	35
4.2 Connecting TR2 Room thermostat	22	8.2.1 Testing the O ₂ or CO ₂ level in the combustion air	35
4.3 Mains Voltage external controls connections	22	8.2.2 Testing CO and CO ₂	35
4.4 Connecting a Hot Water Cylinder	22		
5 Commissioning	23	9 Maintenance	36
5.1 Commissioning	23	9.1 Pre-Service Check List	37
5.2 Switching the appliance on/off	24	9.2 Description of servicing operations	38
5.3 Switching on the central heating	24	9.3 Replacement of Parts	41
5.4 System controls	24	9.3.1 PCB control board and transformer	41
5.5 ZSBR-Appliances with Storage Tank: Setting hot water temperature	25	9.3.2 Fan Assembly	42
5.6 Summer mode, hot water only (ZSBR)	25	9.3.3 Pump	42
5.7 Frost protection	25	9.3.4 3-way diverter valve	42
5.8 Pump anti-seize function	25	9.3.5 3-way diverter valve motor	43
5.9 Fault Condition	25	9.3.6 Sensors	43
6 Text Display	26	9.3.7 Gas Valve	43
6.1 General Description	26	9.3.8 Electrode assembly	44
6.2 Programming	26	9.3.9 Pressure gauge	44
6.2.1 Deleting a setting	27	9.3.10 Expansion vessel	44
6.2.2 Resetting all parameters to their original settings	27	9.3.11 Pressure Relief Valve	44
6.3 Menu structure	27	9.3.12 Burner	44
6.4 Setting the time/day	28	9.3.13 Primary Heat Exchanger	44
6.4.1 Setting the time and day	28		
6.4.2 Holidays	28	10 Appendix	45
6.5 Heating	28	10.1 Fault Codes	45
6.5.1 Heating programme	28	10.2 Short parts list	46
6.5.2 Setting the Economy temperature (if TR2 is connected)	28	10.3 Heating/hot water output settings ZSBR 7-28 N.G.	46
		10.4 Heating/hot water output settings ZSBR 11-28 L.P.G	46
		10.5 Operational Flow diagrams	47
		10.5.1 Central heating function	47

Safety precautions

If you smell gas

- ▶ Turn off gas service cock at the meter.
- ▶ Open windows and doors.
- ▶ Do not operate any electrical switches.
- ▶ Extinguish any naked flames.
- ▶ Telephone your gas company.

If you smell fumes from the appliance

- ▶ Switch off appliance (see page 24).
- ▶ Open windows and doors.

Fitting and modifications

- ▶ Fitting of the appliance or any controls to the appliance may only be carried out by a competent engineer in accordance with the Gas Safety (Installation and Use) Regulations 1998.
- ▶ Flue systems must not be modified in any ways other than as described in the fitting instructions.
- ▶ This appliance is for use on sealed primary systems only.

Maintenance

- ▶ **The user is recommended:** to have the system regularly serviced in order to ensure that it functions reliably and safely.
- ▶ Use only original spare parts!

Combustible materials

- ▶ Do not store or use any combustible materials (paper, thinners, paints etc.) in the vicinity of the appliance.

Health and safety

- ▶ This appliance contains no asbestos products.
- ▶ There is no potential hazard due to the appliance being electrically unsafe.
- ▶ There are no substances used in the construction that are a potential hazard in relation to the COSHH Regulations (Control of Substances Hazardous to Health Regulations 1988).

Combustion air/Ambient atmosphere

- ▶ The combustion air/ambient atmosphere should be kept free of chemically aggressive substances (e.g. halogenated hydrocarbons which contain chlorine or fluorine compounds). This will prevent corrosion.

Instructions to the customer

- ▶ Explain to the customer how the appliance works and how to operate it.
- ▶ Advise the user that he/she must not make any modifications to the appliance or carry out any repairs on it.
- ▶ These instructions are to be left with the user or at the Gas meter.
- ▶ Important: These instructions apply in the UK only.

Symbols



Safety instructions in this document are identified by a warning-triangle symbol and are printed on a grey background.



Notes containing important information are identified by the symbol shown on the left. They are bordered by horizontal lines above and below the text.

1 Details of the appliance

1.1 EC Declaration of Conformity

This appliance is in accordance with the applicable requirements of the Gas Appliance Directive, Boiler Efficiency Directive, Electromagnetic Compatibility Directive and the Low Voltage Directive.

PIN	CE-0085 BL0507
Category UK	II _{2H} 3P
Appliance Type	C ₁₃ , C ₃₃

Table 1

1.2 Standard package

- Gas condensing boiler for central heating and domestic hot water
- Control panel cover
- Wall mounting frame
- Clamp for securing flue duct kit
- Fixings (screws etc.)
- Set of documentation for appliance
- Pre-plumbing manifold
- Condensate drain pipe
- Filling loop
- Room thermostat TR2
- Sensor for Hot Water Cylinder.

1.3 Description of appliance

- Wall-mounted appliance, siting not dependent on room size
- Natural gas models are low-emission appliances
- Multifunction display
- Bosch Heatronic control system with integrated textdisplay for servicefunctions and faults
- 3-channel - digital timer for one heating circuit
- Variable pump
- Automatic ignition
- Modulating control
- Full safety systems incorporating Bosch Heatronic with flame ionisation monitoring, solenoid valves and temperature sensors
- Concentric flue/air duct with testing point for CO₂/CO
- Regulated speed fan
- Pre-mix burner
- Temperature control for central heating
- Safety temperature limiter in 24 V electrical circuit
- Relief valve, pressure gauge, expansion vessel
- Flue gas temperature limiter (105 °C)
- Hot water priority circuit
- Motorised 3-way valve
- Condensate Trap.

1.4 Accessories

- Standard horizontal flue kit at 100 mm outside diameter for flues upto 4 m in length.
- Flue duct kits for horizontal (125 mm outside diameter) for flue lengths upto 13 m and vertical flue systems for flue lengths 15 m. Fitting instructions are sent with these kits.
- Heating programmer,
- Security kit.

1.5 Casing dimensions

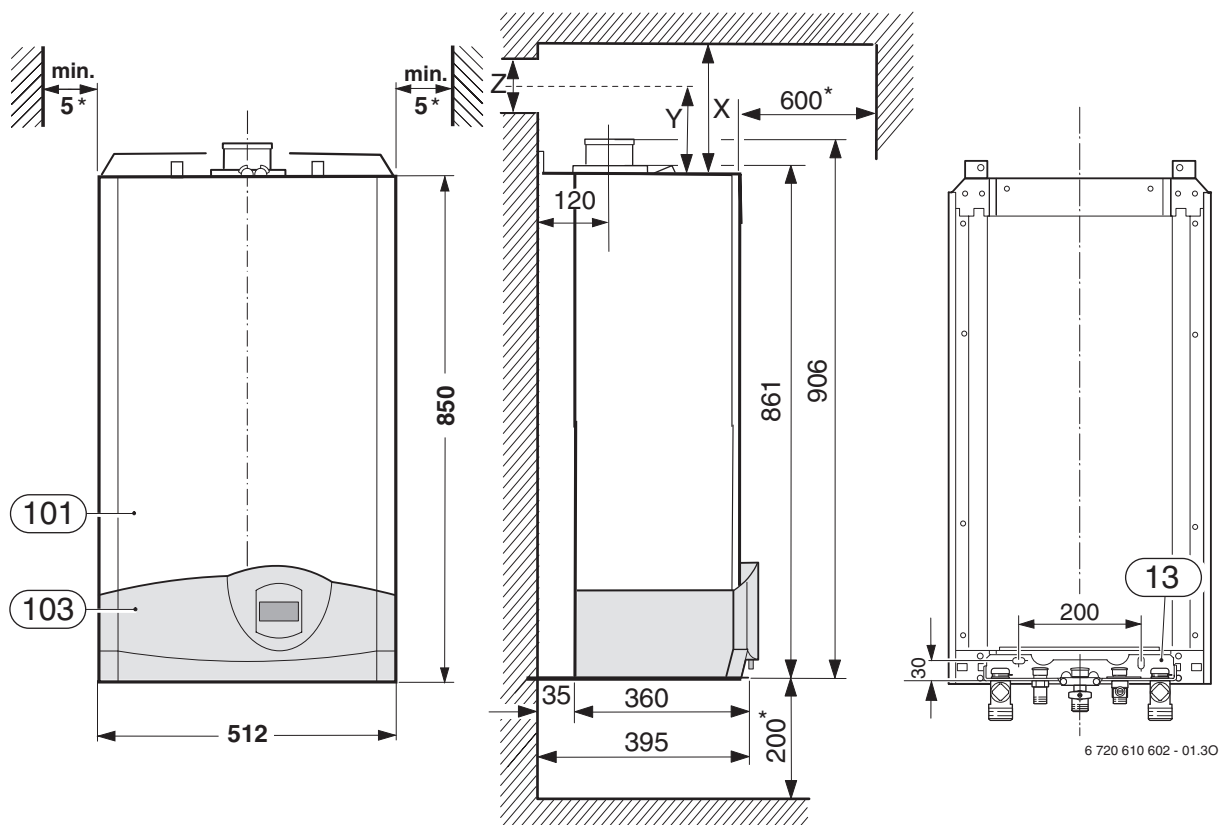

6 720 610 602 - 01.30

Fig. 1

- 13** Manifold assembly
101 Outer case
103 Facia cover
X Standard Concentric Horizontal Flue System: min. 310 mm
 Alternative Concentric Flue System: min. 250 mm
Y Standard Concentric Horizontal Flue System: 158 mm
 Alternative Concentric Flue System: 121 mm
Z Standard Concentric Horizontal Flue System: 105 mm
 Alternative Concentric Flue System: 105 mm
 * For servicing the appliance

1.6 Layout of appliance

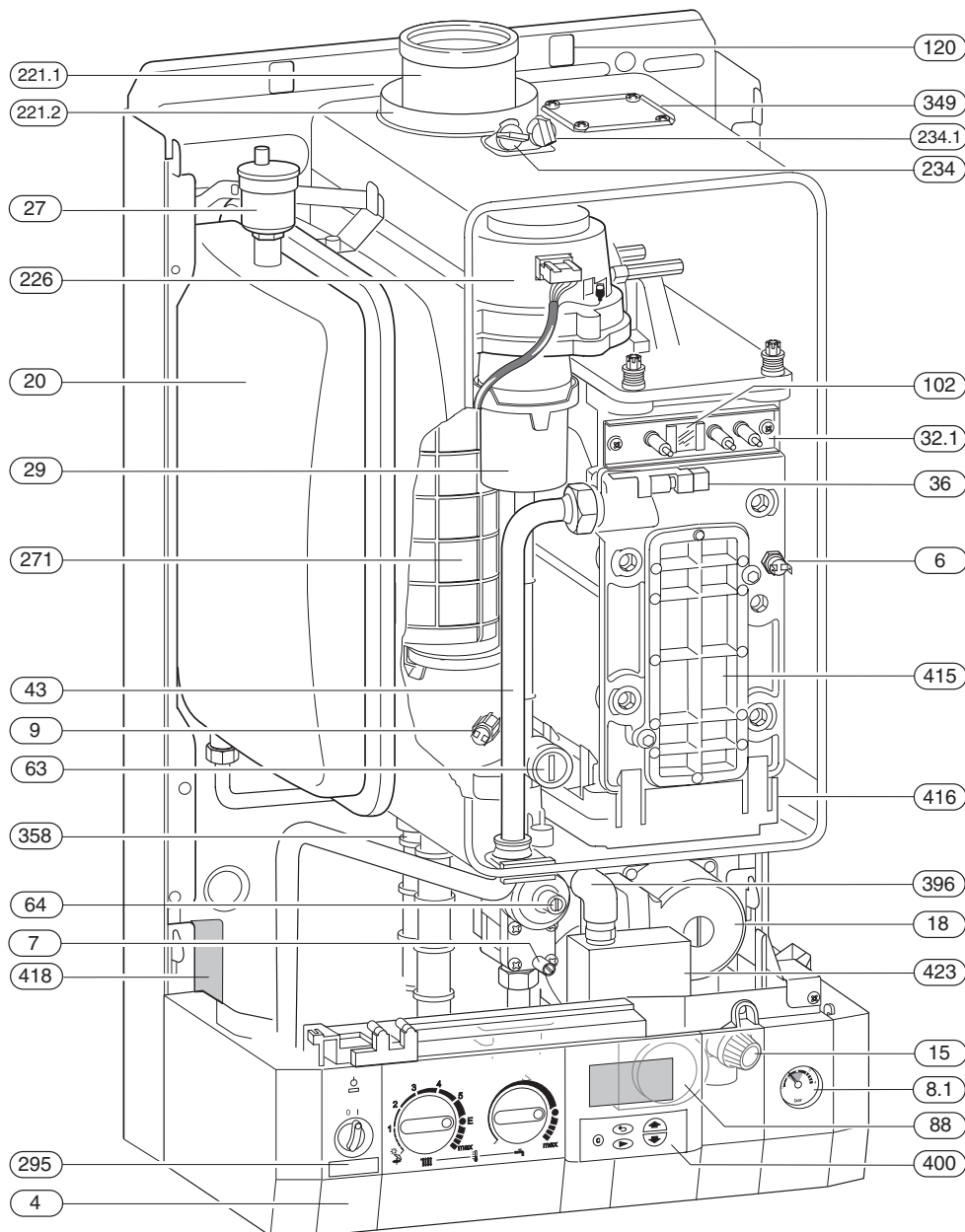

6 720 610 603 - 01.10

Fig. 2

4	Heatronic control	221.2	Combustion air intake
6	Heat exchanger safety temperature limiter	226	Fan assembly
7	Testing point for gas supply pressure	295	Appliance type sticker
8.1	Pressure gauge	234	Testing point for combustion products
9	Flue gas temperature limiter	234.1	Testing point for combustion air
15	Relief valve	271	Flue duct
18	Pump	349	Cover plate for twin flue duct connection
20	Expansion vessel	358	Condensate trap
27	Automatic air vent	396	Hose Condensate trap
29	Air gas Mixer unit	400	Textdisplay
32.1	Electrode assembly	415	Cover plate for cleaning access
36	Temperature sensor in CH flow	416	Condensate collector
43	CH flow	418	Data plate
63	Adjustable gas flow restrictor	423	Siphon
64	Adjusting screw for min. gas flow volume		
88	3-way valve		
102	Inspection window		
120	Fixing points		
221.1	Flue duct		

1.7 Function

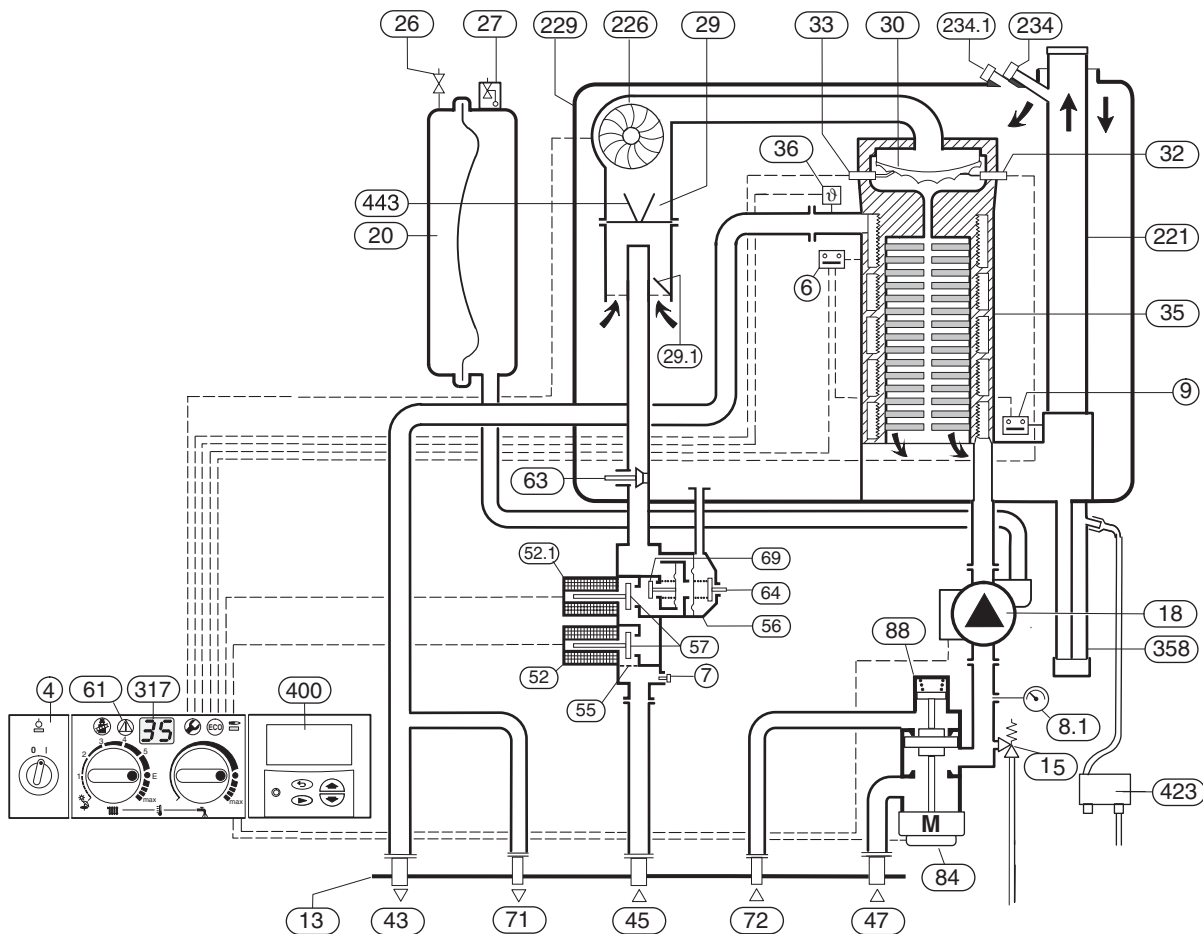

6 720 610 603 - 02.20

Fig. 3

- | | | | |
|-------------|--|--------------|----------------------------------|
| 4 | Bosch Heatronic control | 71 | Storage water heater outflow |
| 6 | Temperature limiter, heat exchanger | 72 | Storage water heater return |
| 7 | Testing point for gas supply pressure | 84 | Motor |
| 8.1 | Pressure gauge | 88 | 3-way valve |
| 9 | Flue gas temperature limiter | 221 | Flue duct |
| 13 | Manifold | 226 | Fan |
| 15 | Safety valve | 229 | Air box |
| 18 | Central heating pump | 234 | Testing point for flue gas |
| 20 | Expansion vessel | 234.1 | Testing point for combustion air |
| 26 | Charging valve | 317 | Display |
| 27 | Automatic vent | 358 | Condensation trap |
| 29 | Mixer unit | 400 | Textdisplay |
| 29.1 | Bi-metallic thermostat for combustion air compensation | 423 | Siphon |
| 30 | Burner | 443 | Diaphragm |
| 32 | Flame sensing electrode | | |
| 33 | Igniter electrode | | |
| 35 | Heat exchanger with cooled combustion chamber | | |
| 36 | Temperature sensor in CH flow | | |
| 43 | CH flow | | |
| 45 | Gas | | |
| 47 | CH return | | |
| 52 | Solenoid valve 1 | | |
| 52.1 | Solenoid valve 2 | | |
| 55 | Filter | | |
| 56 | Gas valve CE 427 | | |
| 57 | Main valve disc | | |
| 61 | Reset button | | |
| 63 | Adjustable gas flow restrictor | | |
| 64 | Adjusting screw for min. gas flow volume | | |
| 69 | Control valve | | |

1.8 Electrical wiring diagram

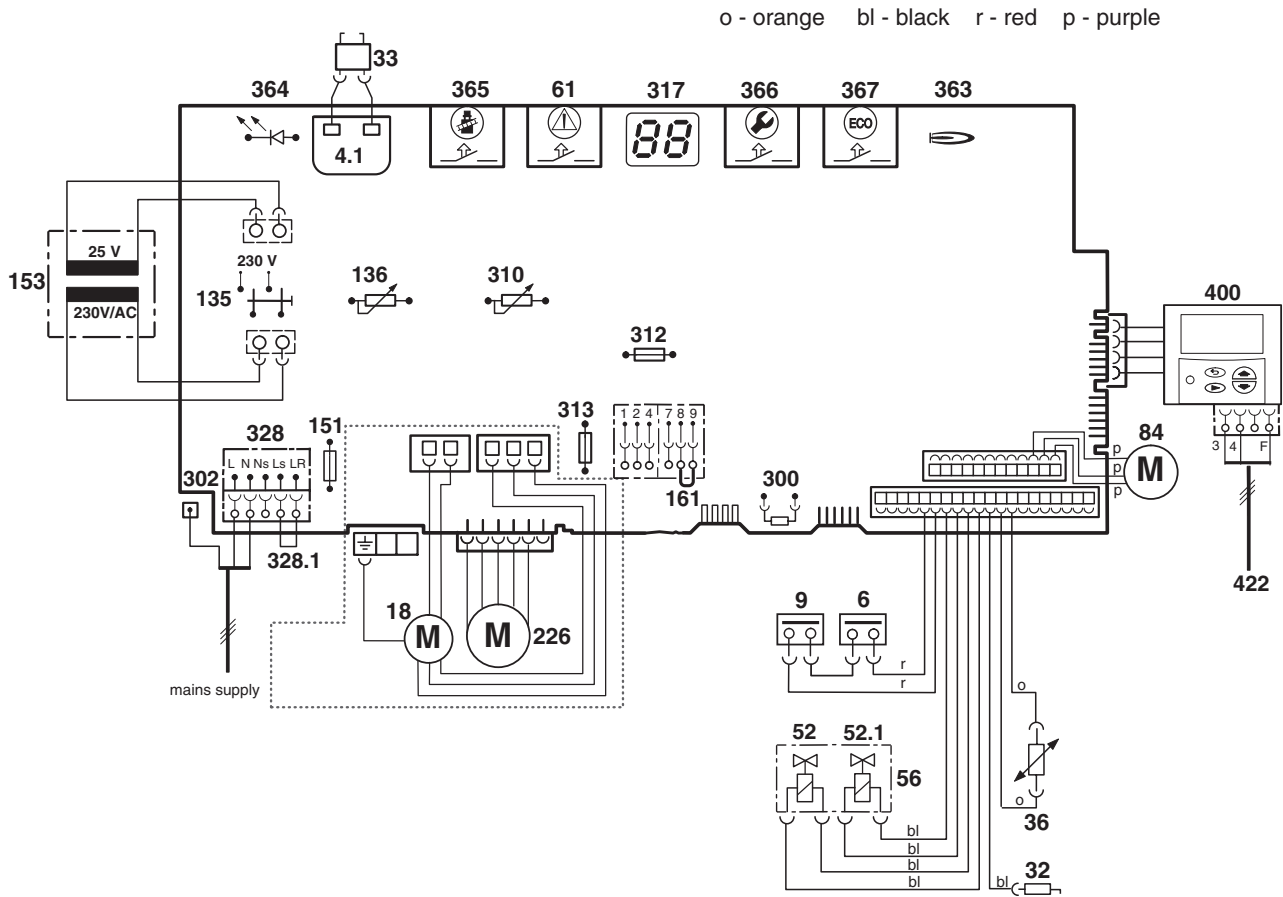

6 720 610 603 - 03.10

Fig. 4

- | | | | |
|--------------|--|------------|---------------------------------|
| 4.1 | Ignition transformer | 364 | Indicator lamp for power supply |
| 6 | Temperature limiter, heat exchanger | 365 | "Chimney sweep" button |
| 9 | Flue gas temperature limiter | 366 | Service button |
| 18 | Pump | 367 | ECO button |
| 32 | Flame sensing electrode | 400 | Textdisplay |
| 33 | Ignition electrode | 422 | Connecting TR2 |
| 36 | Temperature sensor in CH flow | | |
| 52 | Solenoid valve 1 | | |
| 52.1 | Solenoid valve 2 | | |
| 56 | Gas valve CE 427 | | |
| 61 | Reset button | | |
| 84 | Motor, 3-way valve | | |
| 135 | Master switch | | |
| 136 | Temperature control for CH flow | | |
| 151 | Fuse, slow 2.5 A, AC 230 V | | |
| 153 | Transformer | | |
| 161 | Link | | |
| 226 | Fan | | |
| 300 | Code plug | | |
| 302 | Earth connection | | |
| 310 | Temperature control for hot water | | |
| 312 | Fuse, slow T 1,6 A | | |
| 313 | Fuse, slow T 0,5 A | | |
| 317 | Digital display | | |
| 328 | Terminal block for AC 230 V Mains supply | | |
| 328.1 | Link | | |
| 363 | Indicator lamp for burner | | |

1.9 Technical data

	Units	ZSBR 7-28 Natural gas	ZSBR 11-28 Propane
Max. rated heat output net 40/30°C central heating	kW	29.3	29.3
Max. rated heat output net 50/30°C central heating	kW	29.0	29.0
Max. rated heat output net 80/60°C central heating	kW	27.4	27.4
Max. rated heat input net	kW	27.7	27.7
Min. rated heat output net 40/30°C	kW	8.4	11.6
Min. rated heat output net 50/30°C	kW	8.3	11.4
Min. rated heat output net 80/60°C	kW	7.4	10.5
Min. rated heat input net	kW	7.6	10.8
Maximum gas flow rate - After 10 minutes from lighting			
Natural gas G20 (CVnet 34.02 MJ/m ³)	m ³ /h	2.9	-
LPG (CVnet 88 MJ/m ³)	kg/h	-	2.1
Gas supply pressure			
Natural gas G20 (CVnet 34.02 MJ/m ³)	mbar	20	-
LPG (CVnet 88 MJ/m ³)	mbar	-	37
Expansion vessel			
Charge pressure	bar	0.75	0.75
Total capacity	l	18	18
Flue			
Flue gas temp. 80/60°C, rated/min. load	°C	67/55	67/55
Flue gas temp. 40/30°C, rated/min. load	°C	43/32	43/32
Residual delivery pressure (inc. pressure drop in air intake duct)	Pa	80	80
CO ₂ level at max. rated heat output	%	9.2	10.8
CO ₂ level at min. rated heat output	%	8.8	10.5
NO _x -class		5	5
SEDBUK figure, Band A	%	90.7	90.7
Condensate			
Max. condensation rate (t _R = 30°C)	l/h	2.3	2.3
pH-value, approx.		4.8	4.8
General Data			
Electrical power supply voltage	AC ... V	230	230
Frequency	Hz	50	50
Max. power consumption	W	121	121
Noise output level	dB(A)	36	36
Appliance protection rating	IP	X4D	X4D
Max. CH flow temperature	°C	nom. 90	nom. 90
Max. permissible operating pressure (CH)	bar	2.5	2.5
Permissible ambient temperatures	°C	0 - 50	0 - 50
Nominal capacity of appliance	l	3.75	3.75
Weight	kg	50	50

Table 2

Condensate analysis, mg/l

Ammonium	1.2	Nickel	0.15
Lead	≤ 0.01	Mercury	≤ 0.0001
Cadmium	≤ 0.001	Sulphate	1
Chromium	≤ 0.005	Zinc	≤ 0.015
Halogenated hydrocarbons	≤ 0.002	Tin	≤ 0.01
Hydrocarbons	0.015	Vanadium	≤ 0.001
Copper	0.028	pH-value	4.8

Table 3

Flue system

HORIZONTAL 100 mm – Standard			
Overall Diameter of Duct	mm	100	Max. 4 m
Flue Terminal / Duct Assembly Length	mm	600	
Extension Duct Length	mm	1000	

Table 4

ALTERNATIVE HORIZONTAL 125 mm FLUE SYSTEM			
Overall Diameter of Duct	mm	125	Max. 13 m (including turret)
Flue Terminal / Duct Assembly	mm	1030	

Table 5

VERTICAL 125 mm FLUE SYSTEM			
Overall Diameter of Duct	mm	125	Max. 15 m
Flue Terminal / Duct Assembly	mm	1360	

Table 6

Elbow - 90 ° Equivalent length 2 m

Bend - 45 ° Equivalent length 1 m

Gas supply

Total length of gas supply pipe (metres)			Pipe diameter (mm)
3	6	9	
Gas discharge rate (m ³ /h)			
8.7	5.8	4.6	22
18.0	12.0	9.4	28

Table 7

2 Installation regulations

Gas Safety (Installation & Use) Regulations 1998: All gas appliances must be installed by a competent person. Failure to install correctly could lead to prosecution.

The manufacturers notes must not be taken, in any way, as overriding statutory obligations.

The appliance must be installed in accordance with the current IEE Wiring Regulations, local Building Regulations, Building Standards (Scotland) (Consolidation), bye-laws of the local Water Company, Health and Safety Document 635 (Electricity at Work Regulations 1989) and any other local requirements.

Product Liability regulations indicate that, in certain circumstances, the installer can be held responsible, not only for mistakes on his part but also for damage resulting from the use of faulty materials. We advise the installer to avoid any risk by using only quality approved branded fittings.

The relevant British Standards should be followed i.e.

- BS 6798: Specification for the installation of gas fired hot water boilers of rated input not exceeding 60kW
- BS 5449: Central Heating for Domestic Premises
- BS 5546: Installation of gas hot water supplies for domestic purposes
- BS 5440:1: Flues and ventilation for gas appliances of rated input not exceeding 70 kW (net): Flues
- BS 5440:2: Flues and ventilation for gas appliances of rated input not exceeding 70 kW (net): Air Supply
- BS 6891: Installation of low pressure gas pipework installations up to 28 mm (R1).
- BS 7074:1: Code of practice for domestic heating and hot water supply
- BS 7671: Requirements for Electrical Installation.

These instructions must be followed.

3 Installation



- ▶ Always turn off the gas cock before carrying out any work on components which carry gas.



Fixing of the appliance, gas and flue connections, commissioning of the system and electrical connections may only be carried out by competent persons authorised by CORGI.

3.1 Important remarks

- ▶ Appliance should only be installed in sealed central heating and hot water systems.
- ▶ To avoid gas formation in the system, galvanised radiators or pipes must not be used.
- ▶ If a room thermostat is used: do not fit a thermostatic radiator valve on the radiator in the primary room.
- ▶ This appliance uses an automatically variable pump. An auto-bypass must not be fitted.
- ▶ Add a suitable anti-freeze fluid to the water in the central heating system.
Suitable products are available from Betz-Dearborn Tel.: 0151 4209563 and Fernox Tel.: 01799 550811.
- ▶ In our experience, the addition of sealing agents to the water in the central heating system can cause problems (deposits in the heat exchanger). For that reason we advise against their use.

3.2 Sealed systems

The appliance must not be operated without the system being full of water, properly vented and pressurised.

The expansion vessel has a volume of 10 litres and is charged to a pressure of 0.75 bar.

The water capacity of the system is shown in table 10, page 31. If a greater capacity is required then an additional expansion vessel must be fitted into the system return as close to the appliance as possible. The system pressure can be set up to a maximum of 1.5 bar with 1 bar being the normal setting.

If the system pressure is greater than 2.5 bar when the appliance is operating at maximum temperature then an additional expansion vessel must be fitted into the system return as close to the appliance as possible.

The filling point must be at low level and arranged as shown in figs. 5 and 8.

The pressure relief valve is set to operate at 3 bar.

There must be no connection to the mains without the approval of the local water company. All connections in the system must be capable of withstanding a pressure of up to 3 bar and the radiator valves conform to the requirements of BS2767:10.

If Thermostatic Radiator Valves are fitted then it is recommended that the primary radiator is left open.

Repeated venting probably indicates a leak and this must be rectified to ensure the proper operation of the appliance.

No galvanised radiators or pipes must be used.

If any system water treatment is required then only products suitable for use with Aluminium shall be used i.e Fernox- Copal or Superconcentrate or Sentinal X100, in accordance with the manufacturers instructions. The use of any other substances will invalidate the guarantee. The pH value of the system water must be less than 8 or the appliance guarantee will be invalidated.

A drain cock to BS2879 must be fitted to the lowest point of the system.

IMPORTANT: Check that no dirt is left in the water pipework as this could damage the appliance. Thoroughly flush the heating system and the mains water supply before fitting the appliance to the wall in accordance with the recommendations of BS7593:1992.

Note:
A drain cock should be fitted at the lowest point of the heating circuit and beneath the appliance

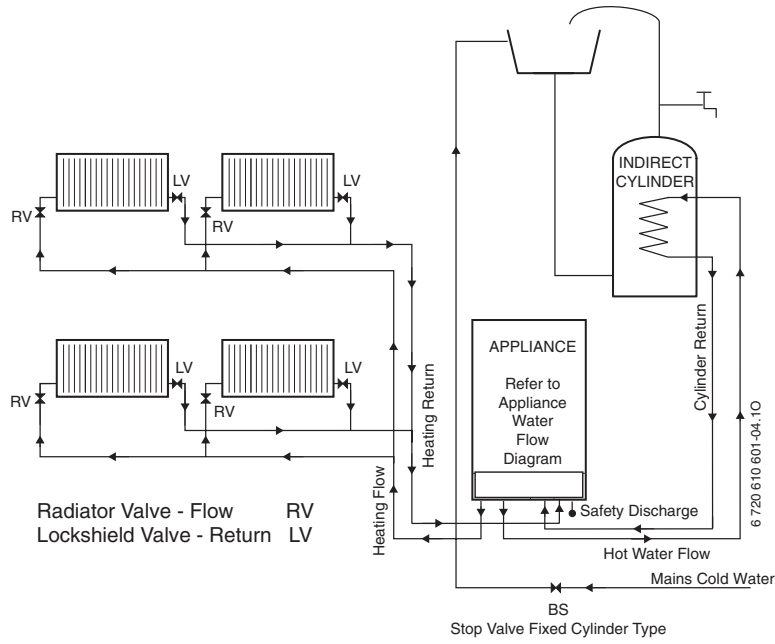

Fig. 5 System layout if using built-in diverter valve

Note:
A drain cock should be fitted at the lowest point of the heating circuit and beneath the appliance

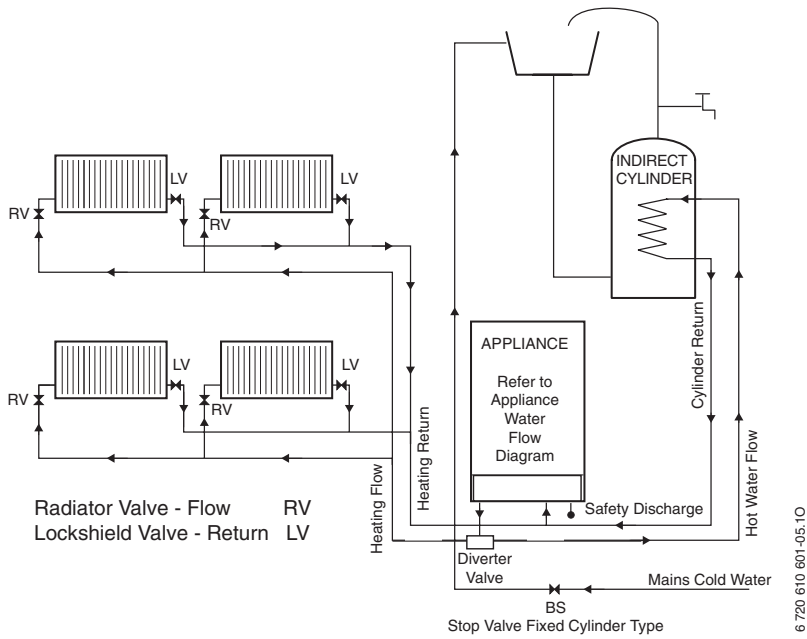

Fig. 6 System layout if using external diverter valve

Note:
A drain cock should be fitted at the lowest point of the heating circuit and beneath the appliance

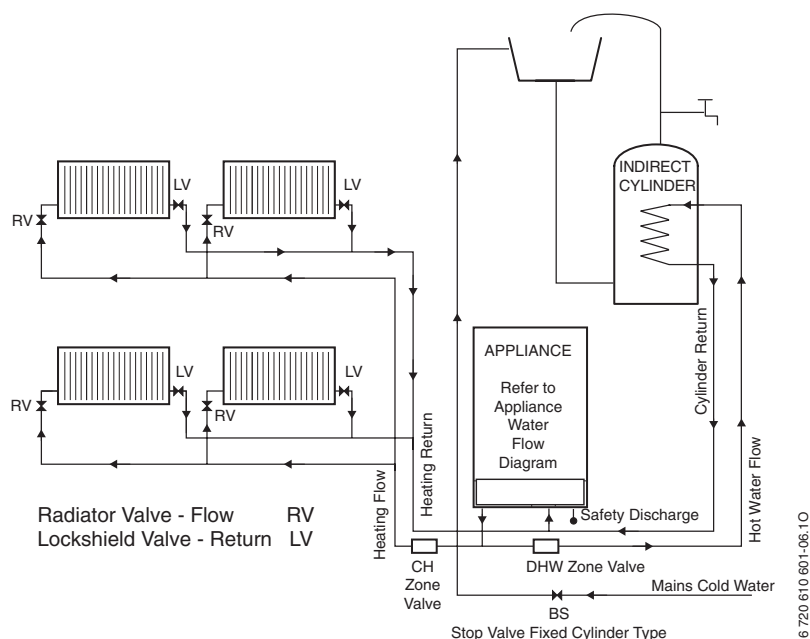

Fig. 7 System layout if using twin zone valves (S) plan

Sealed system filling and make up

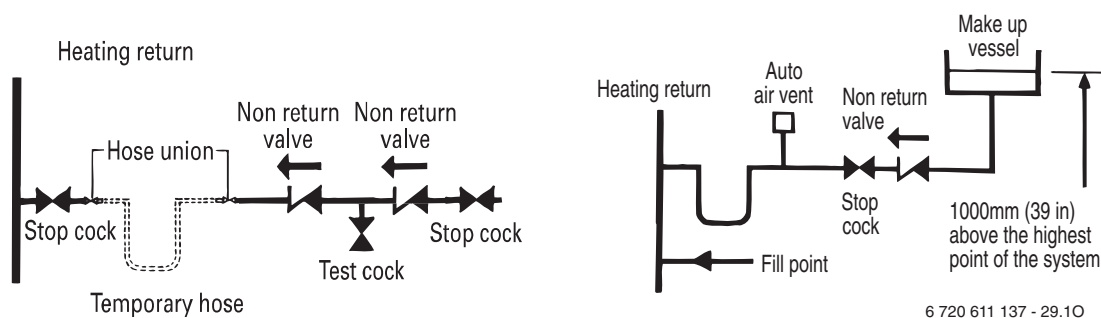

Fig. 8

3.3 Siting the appliance

Regulations concerning the Installation Site

- ▶ Relevant national regulations must be complied with section 3.8.1.
- ▶ Consult the installation instructions for details of minimum clearances required.

Combustion air

In order to prevent corrosion, the combustion air must not contain any corrosive substances.

Substances classed as corrosion-promoting include halogenated hydrocarbons which contain chlorine and fluorine compounds and are contained in some solvents, paints, adhesives, aerosol propellants and household cleaners, for example.

Surface temperature

The max. surface temperature of the casing and the flue is less than 85 °C.

This means that, no special safety precautions are required with regard to flammable building materials and fitted furniture. The specified clearances must be maintained.

Cupboard/Compartment

The appliance can be installed in a cupboard/compartment need for airing clothes providing that the requirements of BS6798 and BS5440:2 are followed. The low casing losses from the appliance eliminate the need for ventilation openings in the compartment.

3.4 Wall mounting frame assembly

- ▶ Take the wall mounting frame out of the package and screw together with 6 screws as shown in fig. 9. Use the outer lugs on the top and bottom horizontal sections for the appliances that are 512 mm wide.

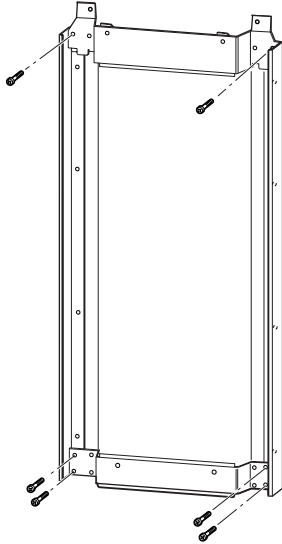

6 720 610 597-06.10

Fig. 9

- ▶ Hold the wall-mounting frame against the wall ensuring that it is vertical.
- ▶ Mark the position of the flue duct hole if a rear flue is to be used. Refer to fig. 1 and 18.
- ▶ Mark the holes for the wall mounting frame onto the wall, drill and plug the holes and screw the wall mounting frame to the wall with the screws provided.

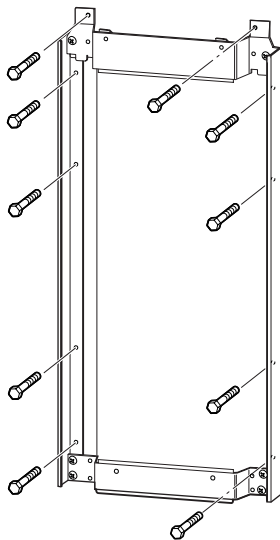

6 720 610 597-07.10

Fig. 10

- ▶ Screw the pre-plumbing manifold with two screws to the wall mounting frame.

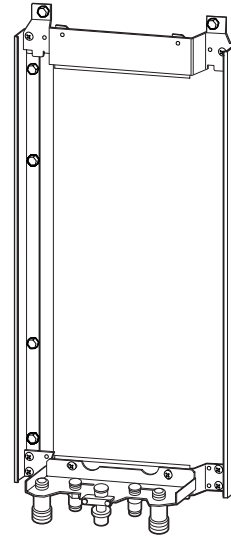

6 720 610 597-08.10

Fig. 11

3.5 Pre-piping the system

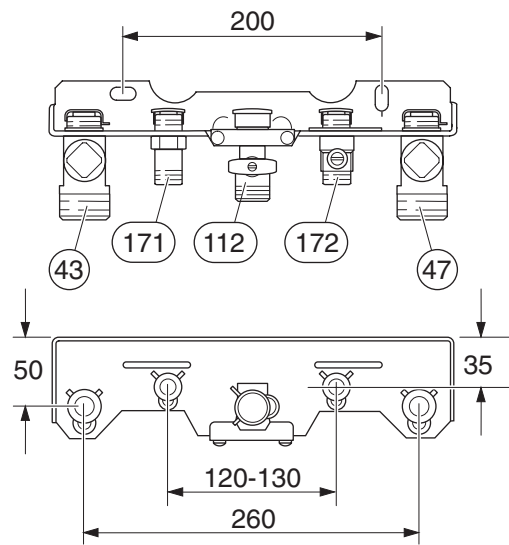

6 720 610 576-06.10

Fig. 12 Manifold

- 43** CH flow
- 47** CH return
- 112** Gas cock
- 171** Domestic hot water
- 172** Cold water relief

- ▶ A drain tap should be fitted at the lowest point of the central heating system.
- ▶ WRAS filling loop must be fitted.

Condensate Termination and Route

The condensate connection on the British Gas/Bosch appliances is in 22 mm plastic. The pipe should be extended and run away from the appliance with a constant fall of 2.5 ° or 40 mm in every metre.

The condensate pipe can terminate into any of four areas:

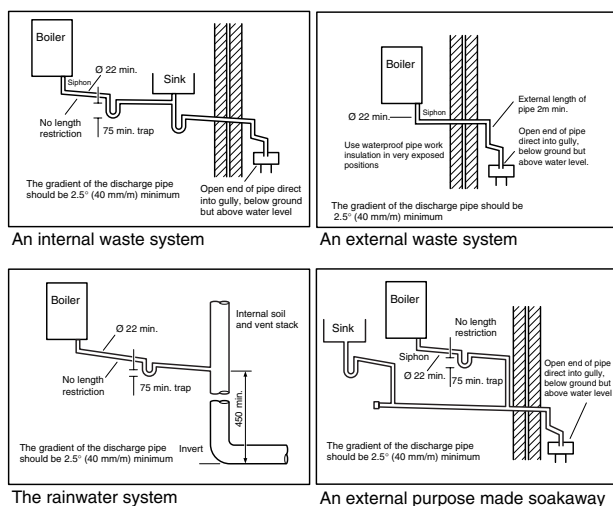

6 720 610 596 -03.10

Fig. 13

Whilst all of the above methods are acceptable it is always the best practice to terminate the condensate pipe via an internal waste system. This will eliminate the need for any external condensate pipe runs which can be susceptible to freezing in extreme weather.

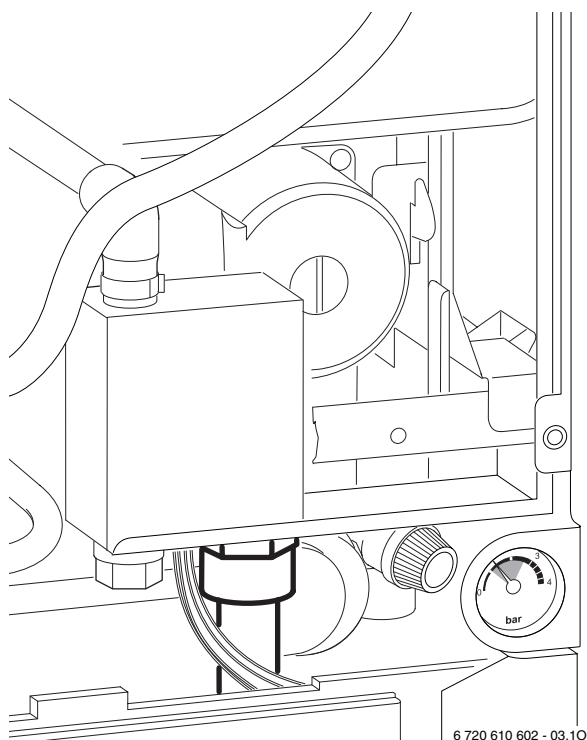

6 720 610 602 - 03.10

Fig. 14 Position of the condensate drain

External condensate pipework

All the British Gas/Bosch condensing boilers have within a syphonic condensate trap. Rather than the condensate constantly dripping into the discharge pipe, the condensate is collected into a trap which releases it in 100 ml quantities.

This will help prevent freezing occurring.

If there is no alternative and the condensate pipe has to be externally run, the following should be considered:

- The pipe run should take the shortest practical route.
- The pipework should be insulated with weather resistant insulation.
- The pipe should terminate as close as possible to the ground or drain, whilst still allowing the condensate to safely disperse. This would prevent wind blowing up the pipe.
- The pipework should be installed with the minimum of horizontal runs and with a downward slope of at least 2.5 °.

3.6 Fitting the appliance



Benchmark: For optimum performance after installation, this boiler and its associated central heating system must be flushed in accordance with the guidelines given in BS5793:1992 "Treatment of water in domestic hot water central heating systems".

- ▶ Remove packing, taking care to observe the instructions on the packing.
- ▶ Lie the boiler on its back.

Removing the outer case



The outer case is secured against unauthorised removal by a retaining bracket (electrical safety) at the bottom left. Always secure the outer case with this bracket again after refitting.

- ▶ Remove retaining screw on left hand side (1.).
- ▶ Press both catch levers backwards (2.).

- ▶ Lift off the top fixing lugs and slide the case forwards and remove (3.).

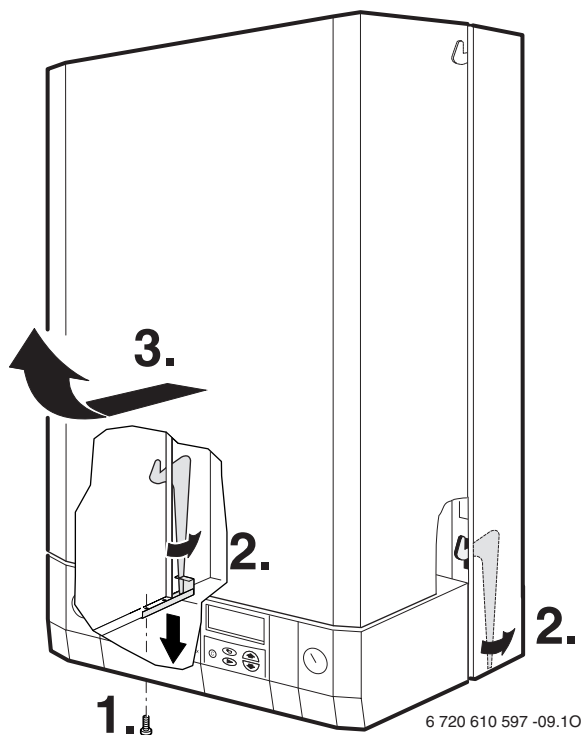

Fig. 15

Fixing the appliance

- ▶ Fit the washers onto the gas and water connections.
- ▶ Lift the boiler onto the wall-mounting frame. The lugs pass through the rectangular holes in the boiler back panel.
- ▶ Take care not to disturb the washers on the connections.

Connecting the flue duct

- ▶ Fit flue duct connector onto appliance flue spigot.
- ▶ Secure with the two screws supplied.

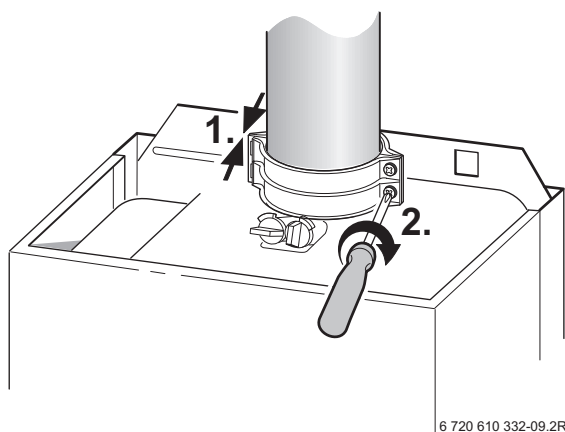

Fig. 16

- ▶ For remaining installation of flue assembly, refer to the relevant installation instructions.

3.7 Checking the connections

Water connections

- ▶ Check that the O-rings or seals are in place before tightening the connection.
- ▶ Turn on the service valves for central heating flow and return and fill the heating system through a WRAS approved filling loop.
- ▶ Check all seals and unions for leaks (testing pressure max. 3.0 bar as indicated by pressure gauge).
- ▶ Turn on cold water service cock and fill hot water system (testing pressure max. 10 bar).
- ▶ Check all connections for leaks.

Gas supply pipe

- ▶ Check that the seal is in place before tightening the connection.
- ▶ Turn off gas cock to protect gas valve against damage from excessive pressure.
- ▶ Check gas supply pipe.
- ▶ Release the pressure on the gas supply pipe.

3.8 Flue Systems

The only flue systems that may be used are those supplied with the boiler.

The flue system must be installed in accordance with the requirements of BS5440:1.

Standard 100 mm flue system

The standard concentric flue system provides for a horizontal length of upto 4 m. Full instructions for fitting this flue are in Subsection 3.8.2 "Installation of the flue".

Alternative 125 mm diameter flue systems

Installation instructions for the alternative flue systems are sent with the appropriate flue kit.

Systems are available to give a maximum horizontal length of 13 m.

A vertical flue system upto a height of 15 metres is available.

45° and 90° flue bends can be used with a corresponding reduction in flue length of 2 m for each 90° bend and 1 m for each 45° bend used.

IMPORTANT: Any horizontal flue system fitted to a condensing boiler must incline towards the appliance at an angle of 3 % (30 mm per metre length) to prevent condensate dripping from the flue terminal. **This means that the clearance above the appliance must be increased to match the duct length. Refer to fig. 1 on page 5.**

3.8.1 Siting the Flue Terminal

The flue must be installed in accordance with BS 5440:1 and the Building Regulations. Flue terminals in carports and under balconies are to be avoided.

The terminal must be positioned so that it does not cause an obstruction nor the combustion products a nuisance. See fig. 17 and table 8.

The terminal will, at times, give out a plume of water vapour and consideration must be given to this when choosing a terminal position. Keep clear of security

lighting, activated by passive infra-red sensing heads. If the terminal is less than 2 m above a surface to which people have access then a guard must be fitted. The guard must be evenly spaced about the terminal with a space of 50 mm in each direction and fixed with plated screws.

A guard Type K6 for the standard horizontal flue, can be obtained from Tower Flue Components, Vale Rise, Tonbridge TN9 1TB.

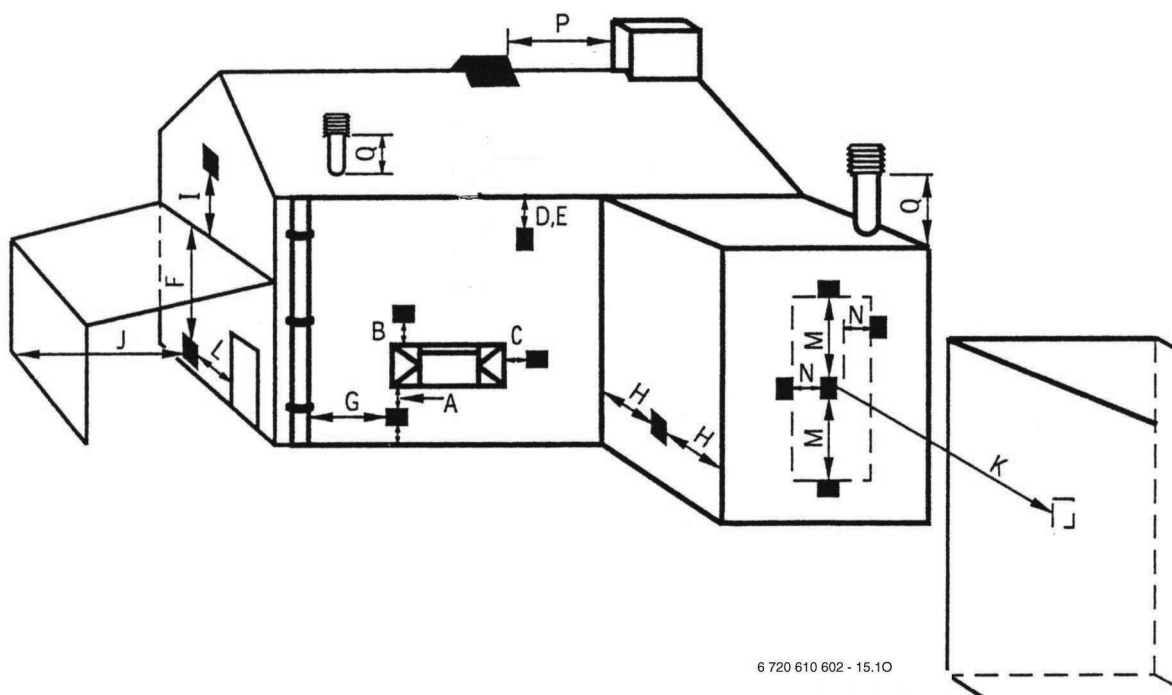

6 720 610 602 - 15.10

Fig. 17

Minimum dimensions of flue terminal positions (all types) (see fig. 17)

Dimension	Terminal Position (kW input expressed in net)	Balanced flues room sealed: Fanned draught
A ¹⁾	Directly below an opening, air brick, opening windows, etc.	300 mm
B ¹⁾	Above an opening, air brick, opening window, etc.	300 mm
C ¹⁾	Horizontally to an opening, air brick, opening window, etc.	300 mm
D	Below gutters, soil pipes or drain pipes	75 mm
E	Below eaves	200 mm
F ²⁾	Below balconies or car port roof (lowest point)	200 mm
G	From a vertical drain pipe or soil pipe	150 mm
H	From an internal or external corner	300 mm
I	Above ground roof or balcony level	300 mm
J	From a surface facing the terminal	600 mm
K	From a terminal facing the terminal	1200 mm
L	From an opening in the car port (e. g. door, window) into the dwelling	1200 mm
M	Vertically from a terminal on the same wall	1500 mm
N	Horizontally from a terminal on the same wall	300 mm
O	From the wall on which the terminal is mounted	Not applicable
P	From a vertical structure on the roof	Not applicable
Q	Above intersection with roof	Not applicable

Table 8

- 1) In addition, the terminal should not be nearer than 150 mm (fanned draught) to an opening in the building fabric formed for the purpose of accommodating a built-in element such as a window frame.
- 2) Not recommended.

3.8.2 Installation of the flue

The standard 100 mm diameter horizontal flue system is suitable for lengths upto 4 m.

Flues upto 650 mm do not require an extension duct assembly.

Flues between 1600 mm and 4000 mm require extension duct assemblies.

NOTE: Flue lengths between 650 mm and 730 mm cannot be accommodated. Refer to fig. 19, 20, 21.

Standard system comprise: Flue turret - Flue turret clamp - Terminal assembly - Wall sealing - plates.
 Extension kit comprises: Air duct - Flue duct - Duct clamp. Refer to fig. 22.

Instructions for fitting other flue systems are packed with the relevant flue kit.

Check that the position chosen for the appliance is satisfactory Refer to fig. 18.

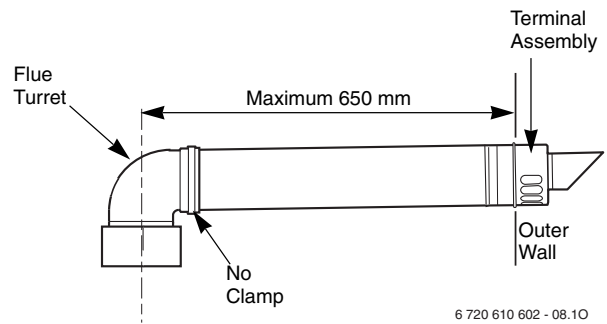

6 720 610 602 - 08.10

Fig. 19 Standard Flue

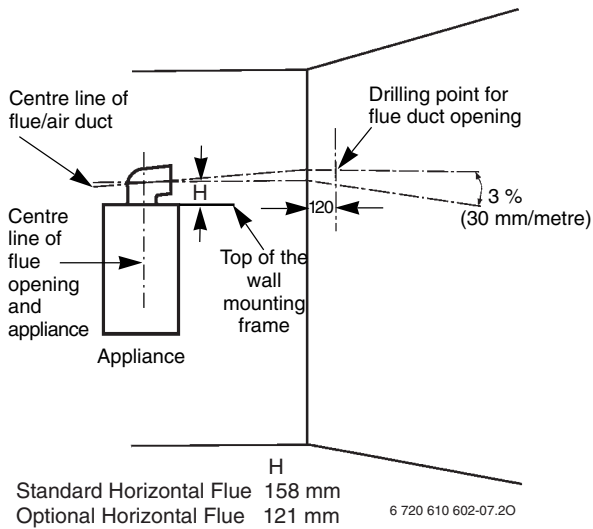

6 720 610 602-07.20

Fig. 18 Marking the position of the side flue opening

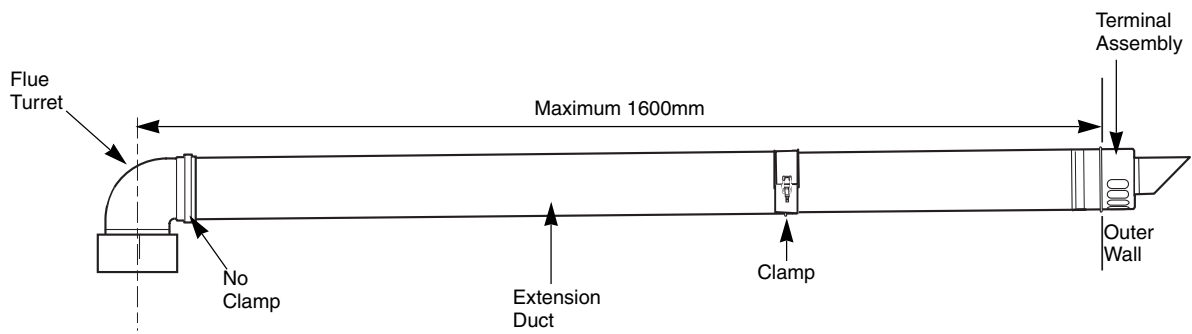

6 720 610 602 - 09.10

Fig. 20 Flue with One Extension

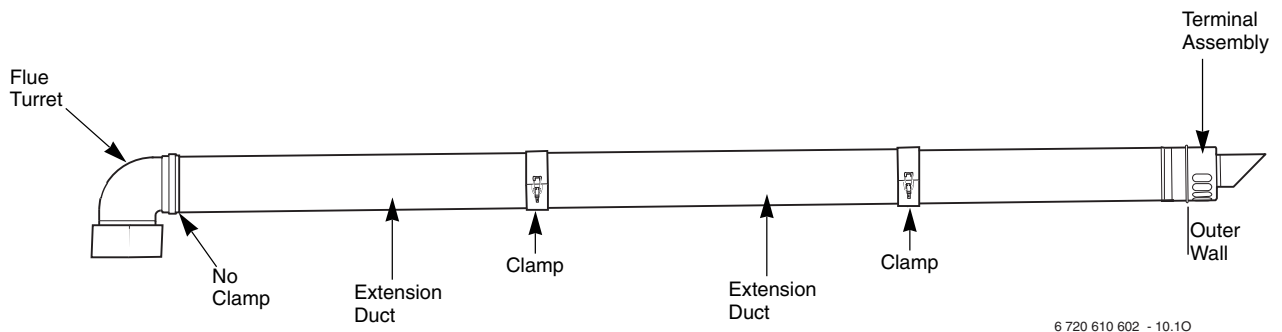

6 720 610 602 - 10.10

Fig. 21 Flue with extensions

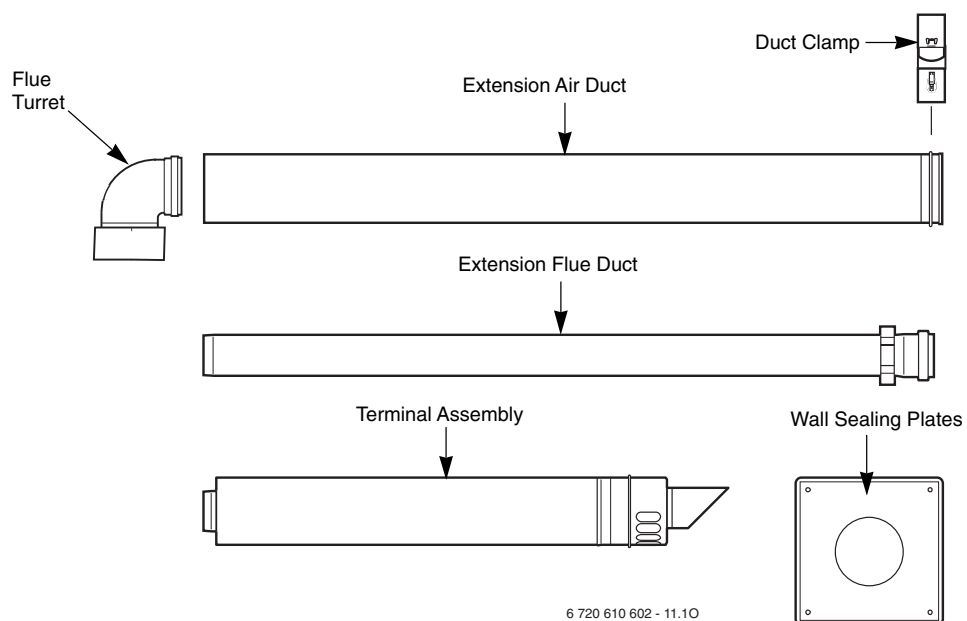

6 720 610 602 - 11.10

Fig. 22 Flue Components

3.8.3 Flue duct preparation and assembly

Measure the flue length L. Refer to fig. 23, 24.

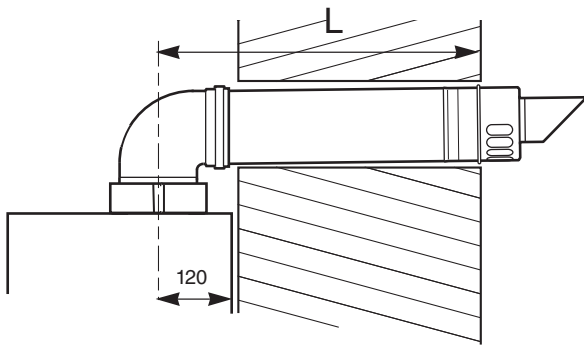

NOTE: THE FLUE MUST BE INCLINED TO THE BOILER
6 720 610 602 - 12.10

Fig. 23 Flue length - rear

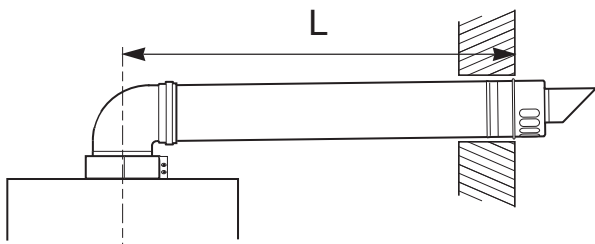

NOTE: THE FLUE MUST BE INCLINED TO THE BOILER
6 720 610 602 - 13.10

Fig. 24 Flue length - side

Mark off the lengths shown onto the ducts and cut to length. The cuts must be square and free from burrs. Terminal assembly outer (air) duct - L- 70 mm, inner (flue) duct - L- 50 mm. The measurement is made from the ridge at the terminal indicating the outer face of the wall. Refer to fig. 25. Extension air duct - L- 70mm, flue duct - L- 50 mm. The measurement is from the formed end.

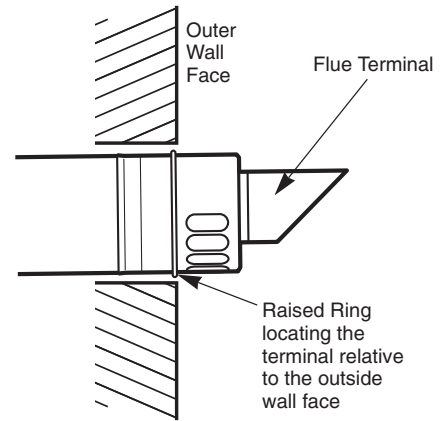

6 720 610 576 - 20.10

Fig. 25 Flue terminal position

Assemble flue system completely. Push the ducts fully together and clamp in the positions. The slope of the terminal outlet must face downwards.

The assembly will be made easier if a solvent free grease is lightly applied i.e Vaseline, to the male end of the ducts.

NOTE: An inner wall sealing plate is provided which should be fitted to the ducts before assembly.

Push the assembly through the wall and fix the turret to the appliance with the clamp. Refer to fig. 26.

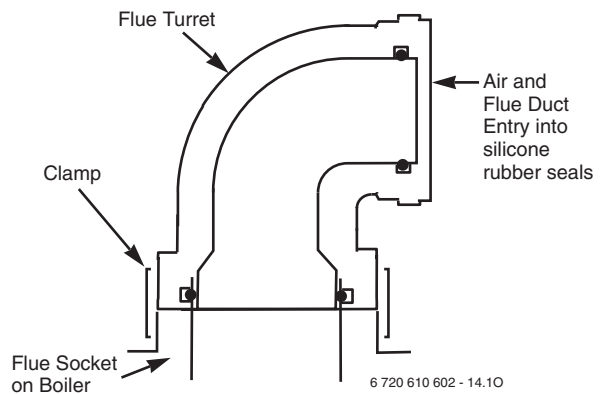

6 720 610 602 - 14.10

Fig. 26 Flue turret

Ensure that the turret is fully entered into the socket on the boiler. From the outside fix the outer wall plate to the terminal and, after ensuring the duct is properly inclined towards the boiler, fix the plate to the wall.

If the terminal is within 2 m of the ground where there is access then an approved terminal guard must be fitted. The guard must give a clearance of at least 50 mm around the terminal and be fixed with corrosion resistant screws.

4 Electrical connections



- ▶ Always disconnect the power supply to the appliance at the mains before carrying out any work on the electrical systems and components.

All control and safety systems are built into the appliance.

- ▶ Allow mains cable to protrude at least 50 cm from wall.
- ▶ To make splash-water proof (IP): cut the cable grommet hole size to match diameter of cable, see fig. 29.

It must be possible to isolate the appliance. The appliance must be earthed.

The appliance must be connected to the mains through a 6 A double pole isolator with a contact separation 3 mm in all poles and supplying the appliance and controls only. The wiring must comply with the current requirements of the IEE Wiring Regulations and any local regulations which apply.

- Supply: 230 V ~ 50 Hz, 140 Watts
- Mains cable: PVC insulated 0.75 mm² (24 x 0.20 mm) to BS6500-Table 6. Temperature rated 100°C.
- Protection IPX4D
- External fuse 3 A.

4.1 Connecting the appliance

To gain access to the mains connection remove the drop down facia cover. The drop down cover is removed by lowering it to the horizontal position and pushing firmly upwards at the rear of the supports to release the cover. Lift cover from the appliance.

After installation (or in the event of an electrical fault) the electrical system shall be checked for short circuits, fuse failure, incorrect polarity of connections, earth continuity and resistance to earth.

- ▶ Pull out cover panel at the bottom and remove. Refer to fig. 27.

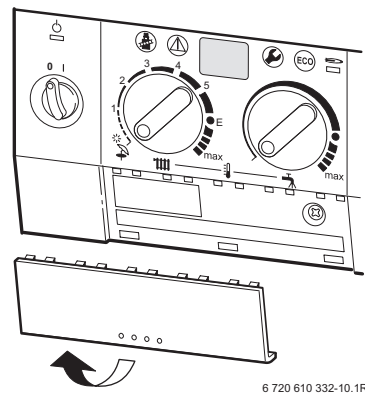

Fig. 27

- ▶ Remove screw and slide terminal cover forwards to remove. Refer to fig. 28.

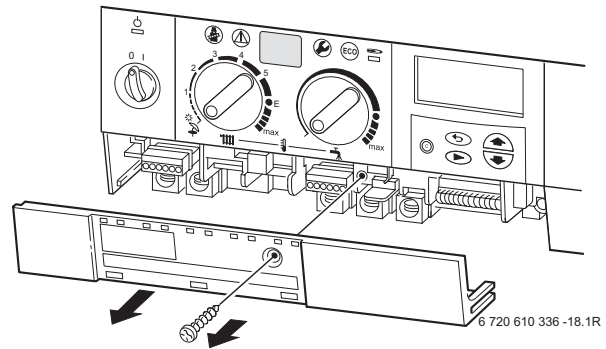

Fig. 28

- ▶ Cut cable grommet to diameter of cable.

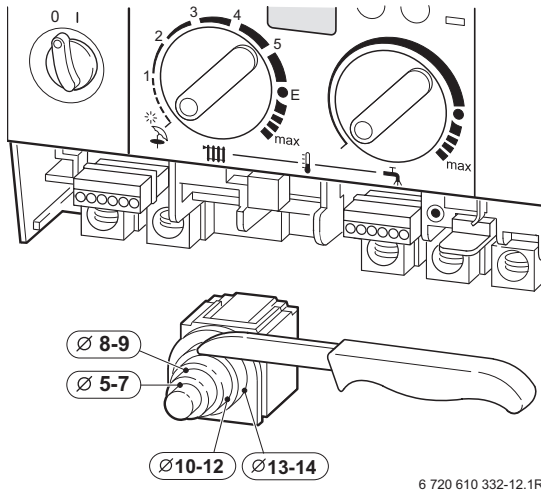

Fig. 29

- ▶ Feed cable through cable grommet and connect the mains supply cable, see fig. 30.
- ▶ Secure cable in cable grommet by means of cable grip.

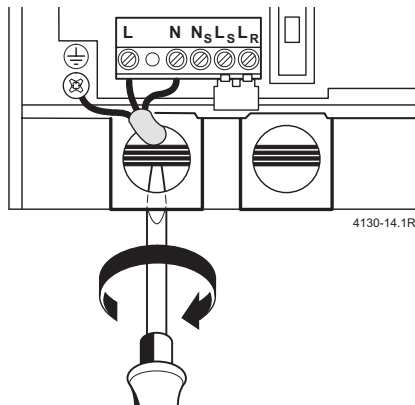

Fig. 30

4.2 Connecting TR2 Room thermostat

The TR2 should be connected to terminals 3, 4 and F beneath the Textdisplay, page 8, Fig. 4, Pos. 422.

4.3 Mains Voltage external controls connections

NOTE: Only double insulated controls not requiring an earth can be used

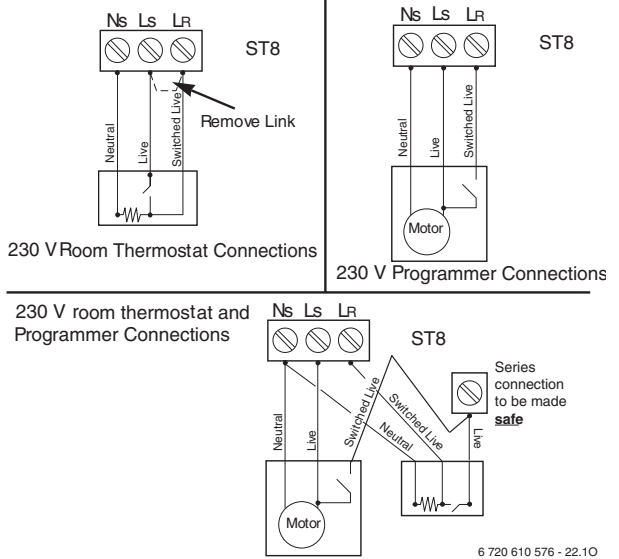

Fig. 31

4.4 Connecting a Hot Water Cylinder

The sensor for the connection is in the package of the appliance.

- ▶ Snap out plastic tongue.
- ▶ Insert cylinder NTC sensor lead.
- ▶ Plug connector into PCB.

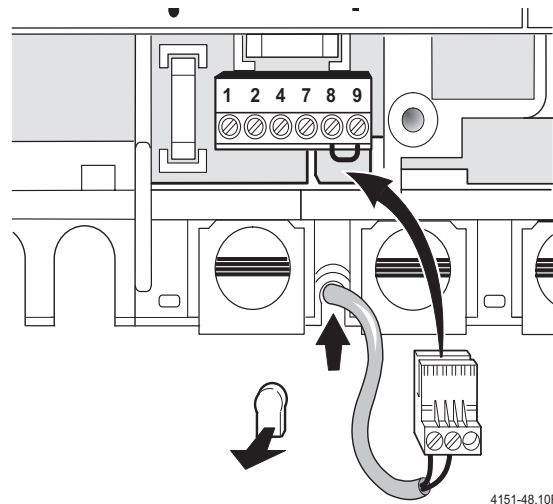
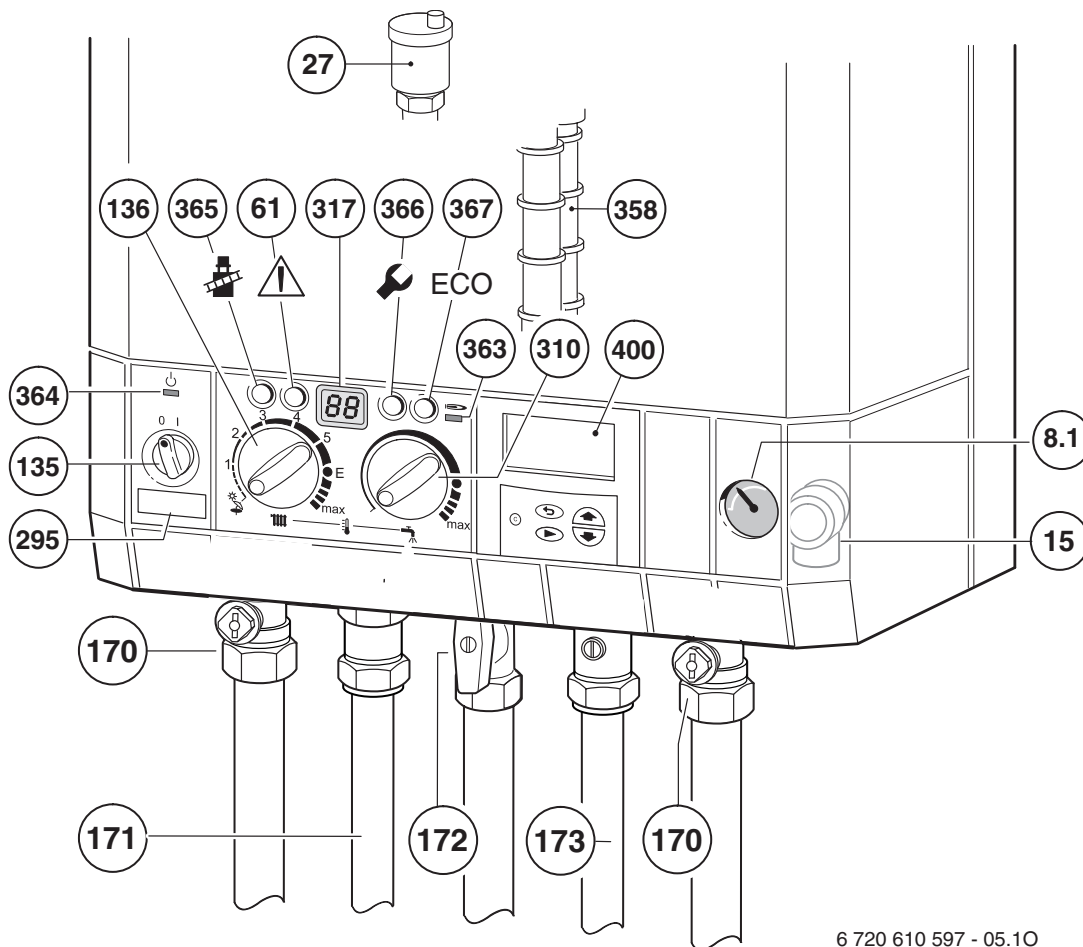

Fig. 32



Position the sensor for the Hot Water Cylinder according to the cylinder manufacturers instruction.

5 Commissioning



6 720 610 597 - 05.10

Fig. 33

- 8.1** Pressure gauge
- 15** Safety valve
- 27** Automatic vent
- 61** Reset button
- 135** Master switch
- 136** Temperature control for central heating
- 170** Service cocks on CH flow and return
- 171** Hot water
- 172** Gas cock (shown in off position)
- 173** Cold water service cock
- 295** Appliance type sticker
- 310** Temperature control for hot water
- 317** Multifunction display
- 358** Condensation trap
- 363** Indicator lamp for burner
- 364** Indicator lamp for power supply
- 365** "Chimney sweep" button
- 366** Service button
- 367** ECO button
- 400** Textdisplay

5.1 Commissioning



Never run the appliance when empty or unpressurised.



The operational CO₂ level is set at the factory and no adjustment is necessary when installing a natural gas fired appliance.

Benchmark Water Treatment: For optimum performance after installation, this boiler and its associated central heating system should be flushed in accordance with the guidelines given in BS7593:1992 - Treatment of water in domestic hot water systems. Full instructions are supplied with proprietary cleansers sold for this purpose. If an inhibitor is to be used after flushing, it should be used in accordance with the inhibitor manufacturers instructions.

To drain the appliance shut the system valves and open the pressure relief valve.

Suitable flushing agents and inhibitors are available from Betz/Dearborn Tel.: 0151 4209563, Fernox Tel.: 01799 550811 and Salamander Tel.: 0121 378 0952. Instructions for use are supplied with the these products.

- ▶ **Before commissioning, the gas supply pressure must be checked at the gas supply pressure test point (see page 6, fig. 2, item 7). Natural gas appliances must not be operated if the gas supply pressure is below 18 mbar or above 24 mbar. LPG appliances must not be operated if the supply pressure is not 37 mbar at the inlet to the appliance.**
- ▶ Unscrew the condensation trap (358) and pull out, fill with approx. 1/4 l of water and refit. Refer to fig. 33.
- ▶ Adjust charge pressure of expansion vessel to static head of the central heating system (see page 31).
- ▶ Open all system radiator valves.
- ▶ Turn on service valves (170), fill central heating system to pressure of 1 - 2 bar through the WRAS approved filling loop. Refer to fig. 33.
- ▶ Vent radiators.
- ▶ Refill heating system and set the pressure to 1 bar.
- ▶ Turn on cold water service cock (173). Refer to fig. 33.
- ▶ Check that the gas type specified on the identification plate matches that of the gas supply.
- ▶ Turn on gas cock (172). Refer to fig. 33.

5.2 Switching the appliance on/off

Switching on

- ▶ Switch on the appliance at the master switch (I). The indicator lamp shows green and the display will show the central heating flow temperature, when the appliance is operating in the central heating mode.

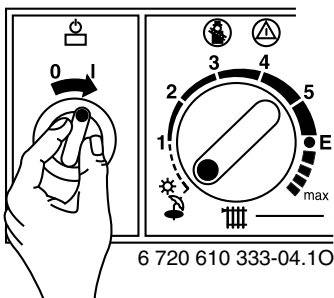

Fig. 34



If the display alternates between **-II-** and the central heating flow temperature, the trap filling programme is active.

The trap filling programme ensures that the condensation trap is filled after the appliance has been installed or after the appliance has been out of use for a long period or the mains supply has been interrupted. For that reason, the appliance remains at minimum heating output for 15 minutes.

- ▶ Open automatic vent (27) and re-close after venting (page 23).

Switching off the appliance

- ▶ Set the master switch to (0). The green indicator lamp goes out. The optional timer will continue running until the emergency supply is exhausted.



▶ Always disconnect the appliance from the power supply (fuse, circuit breaker) before carrying out any work on the electrical systems or components.

5.3 Switching on the central heating

The central heating flow temperature is adjustable between 35°C and 88°C (refer to tables 11, page 31).

- ▶ Turn the temperature control **||||** to set the flow temperature to a level appropriate to the type of central heating system:
 - Underfloor heating: e.g. setting **“3”** (approx. 50°C)
 - Low-temperature heating: setting **“E”** (approx. 75°C)
 - Central heating systems for flow temperatures up to 88 °C: limited **“max”** setting for low-temperature operation (see page 31).

When the burner is alight, the **red** indicator lamp lights up.

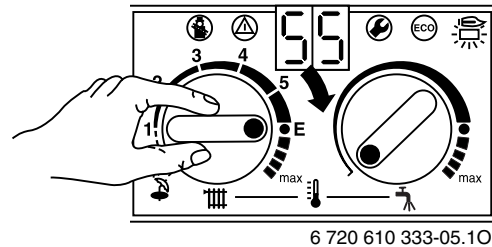

Fig. 35

5.4 System controls

- ▶ Set room thermostat to the desired room temperature.
- ▶ Set outside- temperature driven control unit, if fitted. Refer to the instructions with the control.
- ▶ Set the thermostatic radiator valves to the desired settings.

5.5 ZSBR-Appliances with Storage Tank: Setting hot water temperature



- ▶ Do not set the temperature higher than 60°C for normal operation.
- ▶ Only use temperatures of up to 70°C temporarily for thermal disinfection purposes.



With the text display you can additionally set hot water charging times or times and temperatures.

- ▶ Set the hot water temperature by means of the temperature control  on the appliance.

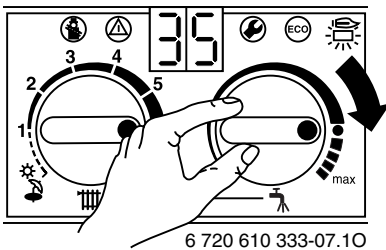

Fig. 36

Control Setting	Water Temperature
Anti-clockwise limit	approx. 10°C (frost protection)
●	approx. 60°C
Clockwise limit	approx. 70°C

Table 9

ECO button

Pressing and holding the ECO button , until it lights up switches from **Comfort mode** to **ECO-mode**.

Comfort mode, ECO button is not lit (factory setting)

Comfort mode the hot water tank has priority. The hot water cylinder is first heated up to the set temperature. The appliance then switches to central heating mode.

ECO mode, button is lit

In ECO mode the appliance switches between central heating mode and cylinder charging mode every 12 minutes.

5.6 Summer mode, hot water only (ZSBR)

With room thermostat

- ▶ Turn temperature control  on the appliance anti-clockwise as far as the stop. The central heating is now turned off. The hot water function and the mains power supply for the heating programmer and timer remain switched on.

5.7 Frost protection

- ▶ Leave master switch switched on.



Frost protection and constant frost protection modes can be set on the text display module.

If the appliance is to be left for long periods switch the central heating off:

- ▶ Add a suitable anti-freeze fluid to the water in the central heating system. Suitable products are available from Betz-Dearborn Tel.: 0151 4209563 and Fernox Tel.: 01799 550811.

5.8 Pump anti-seize function



This function prevents the central heating pump seizing after long periods of inactivity.

Every time the pump is switched off, a timer is started. If after 24 hours the pump has not run again, it is switched on for a period of 10 seconds.

5.9 Fault Condition



A list of faults that may occur is given on page 45.

In the unlikely event of a fault occurring while the appliance is in operation:

The display and the textdisplay then show a fault code and the button  may also flash.

If the button  flashes:

- ▶ Press and hold the button  until the display shows “- -”. The appliance will then start up again and the display will show the central heating flow temperature.

If the button  does not flash:

- ▶ Switch the appliance off and then on again at the master switch. The appliance will start up again and the central heating flow temperature will be displayed.

6 Text Display

6.1 General Description

- The text display is used to display information about the appliance and the system and to alter the settings displayed.
- Once the appliance has been in operation for one day, the text display module has a power buffer period of about 10 hours during which it will run without the mains power supply. After that period has elapsed, the clock function shuts down but all other settings are retained.

6.2 Programming

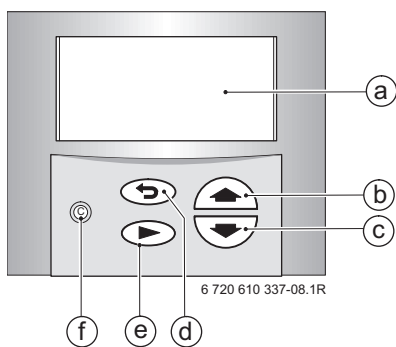

Fig. 37 Controls

- a Display
- b "Up"/"More" button
- c "Down"/"Less" button
- d "Back" button
- e "Next" button
- f "Delete" button

The standard display shows the following information:

- Time
- Room temperature (if TR 2 connected)
- CH flow temperature
- Domestic Hot Water temperature (ZSBR if a Storage Tank is accorded).

Additional indication if a special programme is active:

- x holidays
- Hot water immediately
- Constant on (comfort, if TR2 is not connected)
- Constant off (economy, if TR2 is not connected).

Other special operating modes may be displayed during commissioning, servicing, etc.

The programming procedure is described in detail below **using the clock** function as an example:

- ▶ To start programming, press any button, e. g. . The display lighting switches on and the main menu is displayed:

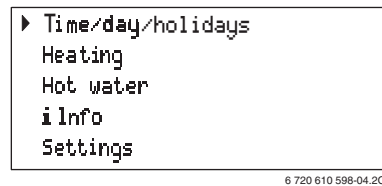

Fig. 38 Main menu

- ▶ Use the or button to move the cursor arrow on the left of the menu so that it points to the desired menu item. In this example, the cursor is positioned next to the menu item **Time/day/holidays**.
- ▶ Confirm the selection by pressing the button. The corresponding submenu is displayed:



Fig. 39 Submenu: Time/day

In the submenus, the top line indicates what action is required.

The bottom line shows the previous menu level, if applicable (see Fig. 40).

- ▶ Use the or button to select **Time/day**.
- ▶ Confirm the selection by pressing the button. The corresponding submenu is displayed:

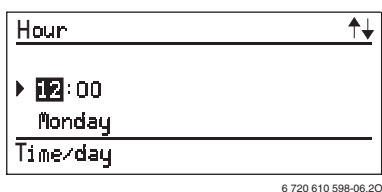



Fig. 40 Setting the hour

When settings are being entered, the setting to be altered is indicated on the top line. In addition, the setting being altered is displayed with a dark background.

- ▶ Use the or button to set the hour.
 - Press and release to change the display by one unit at a time
 - Press and hold to change the display rapidly
- ▶ Confirm the setting by pressing the button.
- ▶ Use the or button to set the minutes.
- ▶ Confirm the setting by pressing the button.
- ▶ Use the or button to set the day of the week.

- ▶ Press the  button to confirm the setting. The cursor then returns to the top line.

-or-

- ▶ Press the  button to confirm the setting and return to the previous menu (Fig. 39 page 26).

-or-

- ▶ Do not press any other buttons for 15 minutes.

6.2.1 Deleting a setting

Either overwrite the setting or press the  button to delete it.

- ▶ Find the setting to be deleted.
- ▶ Press and release the  button.
The display shows --:--

6.2.2 Resetting all parameters to their original settings



The hours of service can not be reset to 0.

- ▶ Press and hold the  button for more than 15 seconds.

After about 5 seconds, the following message appears on the display:

ATTENTION

Delete all parameters in x seconds

Once the reset has been completed, the following message is displayed:

Please wait... Initialising

6.3 Menu structure

Main menu	Submenu			Parameters to change/select	Page	
	1.	2.	3.			
Set hour/day	Set hour/day	-	-	- Hours - Minutes - Day of week	28	
	Holidays	-	-	Days holiday	28	
Heating	Heating program	-	-	- Day - 1st operating mode - 1st switching point ... - 6th switching point	28	
	Set economy temp. (if TR2 is connected)	-	-	5...30°C	28	
	Manual (if TR2 is not connected)	-	-	- Automatic - Constant on (comfort) - Constant off (economy)	29	
Hot water	Hot water program	-	-	- Day - 1st operating mode - 1st switching point ... - 6th switching point	29	
	Hot water immediately	-	-	Off/On	29	
Info	-	-	-	-	29	
Settings	Heating	-	-	Optimum Start Off/On	30	
	Hot water (ZSBR-models)	-	-	Only charging times/times and temperatures	29	
	Service	Display service param.	-	-	-	30
			Further options	Language	-English/ -Français/ -Deutsch	30
		-Time correction -LCD contrast			30	
		Operating times		-	-	-
Fault history			-	-	-	30

6.4 Setting the time/day

6.4.1 Setting the time and day

For details of how to set the time and day, refer to page 26.



Changing winter and summer time:

- ▶ Only adjust the clock! Do not alter the switching points (for heating, economy, etc.).

6.4.2 Holidays

In the Holiday programme, the central heating runs in Economy mode and the hot water is switched off (frost protection function remains active).

- ▶ From the main menu, select **Time/day/holidays**, and from the first submenu select **Holidays**.
- ▶ Enter the number of days holiday by pressing or (max. 99 days holiday).
After the set number of days, the text display module automatically cancels Economy mode at midnight on the last day and returns to Automatic mode.



The day on which you enter the days holiday counts as the first day of the holiday, i.e. the unit starts the holiday program immediately. Only include the day on which you are returning if you **don't** want the heating to return to the normal program on that day!

To cancel Holiday mode early:

- ▶ In the **Holidays** submenu:
Press the button until the display shows **0**.

6.5 Heating

6.5.1 Heating programme

Basic setting (Automatic mode)

- The appliance switches automatically between normal heating, Economy mode and Frost protection mode according to the timer settings entered.
- Basic setting:
 - Heating starts at 6:00 am
 - Economy starts at 10:00 pm

Setting options

- Maximum of six switching points per day with three different operating modes (Heating, Economy, Frost protection).
- Same times for Monday to Friday.
- Same times for Saturday and Sunday.
- Different times for every day.

Setting switching times and operating mode

- ▶ From the main menu select **Heating** and then from the first submenu, select **Heating program**.
- ▶ Select **Monday - Friday**, Saturday and Sunday or an individual day of the week.
 - **Monday - Friday**: to have "Heating" and "Economy" or "Frost protection" switching on at the same times every weekday.
 - **Saturday - Sunday**: to have "Heating" and "Economy" or "Frost protection" switching on at the same times Saturday and Sunday.
 - Individual day of the week (e. g. **Thursday**): to have the relevant program always switching on at the specified time on that day of the week, i.e. "Heating", "Economy" or "Frost protection" at the same time every Thursday.
- ▶ Press . The display shows **Set 1. operating mode**.
- ▶ Set the desired first operating mode (Heating, Economy or Frost protection).
- ▶ Press . The display shows **Set 1. time period**.
- ▶ Set the desired first time period.
- ▶ Press . Set the following operating modes and time periods as described for the first.
- ▶ If necessary: select the next day and enter the operating modes and timer periods as described above.



If the settings for a particular day of the week are different from the settings for the other days, then if **Monday - Friday or Saturday and Sunday** is selected, the display shows **--:--**, i.e. there are no common switching points for those options.

Timer periods and operating modes are you do not wish to change can be skipped by pressing .

6.5.2 Setting the Economy temperature (if TR2 is connected)

This option allows you to set the room temperature for **Economy mode (Off (Economy))**.

This function is only active if:

- Automatic mode or Economy mode is set on the TR2 room thermostat.
- ▶ From the main menu, select **Heating** and then from the first submenu, select **Set Economy temp.**
- ▶ Use the or button to set a temperature between 5 and 30 °C.

6.5.3 Manual operating mode (if TR2 is not connected)

For selecting an operating mode that is different from the one set in the heating programme (**Automatic mode**).

- You can choose between **Automatic, Constant on (comfort)** and **Constant off (economy)**.
 - The manually selected operating mode starts immediately.
 - Constant off (economy) and Constant on (comfort) are automatically reset at 00.00 (midnight).
 - To cancel the manually selected operating mode:
 - select the relevant menu and then press the  button,
 - or select a different operating mode,
 - or set **Holiday**.
- From the main menu select **Heating** and then from the first submenu **Manual** select required mode.

6.6 Hot water



General description

- **ZSBR models (with Storage Tank):** The basic settings provide a timer programme: enable from 5:00 am, disable from 10:00 pm. With the menu **Hot water** (see page 30) you can choose a timer-/temperature programme with the basic settings: 60°C from 5:00 am, 10°C from 10:00 pm.

6.6.1 Hot water programme

- Up to six switching points per day can be set.
 - There are two operating modes: Blocked and Released.
- From the main menu, select **Hot water** and then from the first submenu, select **Hot water program**.
- Set the days of the week, Blocked/Released (operating mode) in the same way as for the switching points and modes for heating as described on page 28.

6.6.2 Hot water immediately

- **Hot water immediately ON:**
 - Comfort mode is active for 2 hours.
 - **Comfort mode is active for 2 hours:** normal automatic program (Hot water mode according to timer programme entered).
- From the main menu, select **Hot water** and then from the first submenu, select **Hot water immediately**.
- Press  or  to switch **Hot water immediately** on or off.

6.7 i Info

- Select **Info** from the main menu.



You can view the following information:

Display text	Description
Room temperature (if TR 2 connected)	Current temperature in the room where TR 2 is installed
Required room temperature (if TR 2 connected)	Required temperature in room where TR 2 is installed
Operating mode (if TR 2 connected)	E. g. Heating, Economy in Automatic mode or Economy, Heating, Frost protection in manual mode
Max. flow temp.	Maximum CH flow temperature set on the temperature control for CH flow
Actual flow temp.	Actual CH flow temperature
Required flow temp.	Required CH flow temperature
Max HW temp.	Maximum permissible hot water outflow temperature
Required HW temp.	Required hot water temperature
Actual HW temp.	Actual hot water outflow temperature
Storage Tank charge released or blocked	Shows, if hot water is released or blocked
Storage Tank charge on or off or Storage Tank charge afterrunning	Shows, if hot water is on or off, or if the pump for the Storage Tank afterrunning is on
Boiler operat. mode winter/ summer	Indicates which mode the CH flow temperature control is set to
Burner on/off	Indicates whether the burner is alight or not
Pump on/off	Indicates whether the integral pump is switched on or off

6.8 Settings

6.8.1 Heating (if TR 2 is connected)



Optimum Start

- ▶ From the main menu, select **Settings** and from the first submenu, select **Heating**.
- ▶ Press  or  to switch Optimum Start on or off.

Basic setting: "ON"

6.8.2 Hot Water (Storage Tank, ZSBR models only)

The text display can control the hot water either with **Times and temperatures** or **only times**.

- **Times and temperatures:** One can choose up to six different times with temperatures, see page 29 "Hot water".
- **Only times:** During that times the Storage Tank will be charged to the choosed temperature.
- ▶ From the main menu, select **Settings** and from the first submenu select **hot water**.
- ▶ Press  or  to switch Times and temperatures or **only times**.



Turn the hot water temperature control  always higher than the temperature at the text display is choosen.

6.8.3 Service



Displaying service functions

This option displays various current settings and statuses of the electrically controlled appliance and system components for the benefit of the heating engineer.

Service parameters

Language



Available languages are: English, Français (French), Deutsch (German).



- ▶ From the main menu, select **Settings**, from the first submenu select **Service**, from the Second submenu select **Further options**, and from the third submenu select **Language**.
- ▶ Press  or  to select the desired language.

Two other supplementary functions can be selected from the third submenu Language:

- Time correction
- LCD contrast.







Time correction:

- ▶ Press and hold the  button (about 5 seconds) until the display shows **Time correction and LCD contrast**.
- ▶ Press  or  to select **Time correction**.

- ▶ Press the  button. The display shows **Change value**.
- ▶ Press  or  to set the number of seconds in 24 hours.

Basic setting: "+ 0 s"

LCD contrast:

- ▶ Press and hold the  button (about 5 seconds) until the display shows **Time correction and LCD contrast**.
- ▶ Press  or  to select **LCD contrast**.
- ▶ Press the  button. The display shows **Change value**.
- ▶ Press  or  to adjust the **LCD contrast**.

Basic setting: e. g. "47"

Operating times

This option shows the hours of service (appliance, burner and hot water) since commissioning.

- ▶ From the main menu, select **Settings**, from the first submenu select **Service**, from the Second submenu select **Further options**, and from the third submenu select **Operating times**.

Fault history

This option displays any faults that have occurred for the information of the service engineer. The first fault displayed may still be active. Any other faults displayed are no longer active.

- ▶ From the main menu, select **Settings**, from the first submenu select **Service**, from the Second submenu select **Further options**, and from the third submenu select **Fault history**.

6.9 Individual timer programmes

Tables for your own timer programmes you find in the User Manual.

7 Individual settings

7.1 Mechanical settings

7.1.1 Checking the size of the expansion vessel

Maximum pressure at maximum CH flow temperature is 2.5 bar. If the pressure is greater than this then fit an extra expansion vessel. Refer to table 10.

System Capacity – BS7074:1

Expansion Vessel Pressure and System Capacity			
Expansion Vessel	litres		18
Expansion Vessel Charge Pressure	bar		0.75
System pressure and capacity	1 bar	litres	147
	1.5 bar	litres	82

Table 10

7.1.2 Setting the central heating flow temperature

The central heating flow temperature can be set to between 35°C and 88°C.



With underfloor heating systems, observe the maximum permissible flow temperatures.

Limited maximum setting for low-temperature operation

The temperature control is factory limited to setting **E**, giving a maximum flow temperature of 75°C.

Adjustment of the heating output to the calculated heat demand is not required by the heating systems regulations.

Removing the maximum setting limit

For heating systems which require higher flow temperatures, the maximum setting limit can be removed.

- ▶ Lift off the yellow button on the temperature control  with a screwdriver.

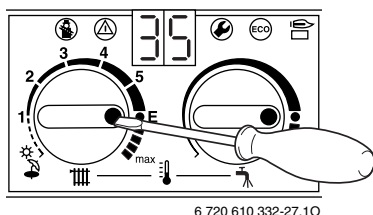

6 720 610 332-27.10

Fig. 41

- ▶ Rotate yellow button through 180° and replace (dot facing inwards).
The CH flow temperature is no longer limited.

Control setting	CH flow temperature
1	approx. 35°C
2	approx. 43°C
3	approx. 51°C
4	approx. 59°C
5	approx. 67°C
E	approx. 75°C
max	approx. 88°C

Table 11

7.2 Settings on the Bosch Heatronic

7.2.1 General description

The text display module provides a convenient means of setting various appliance functions.

This description is limited to those functions necessary for commissioning.

Service function	Code no.	see page
Anti-cycle time	2.4	32
Max. CH flow temp.	2.5	32
Max. heating output	5.0	32
Variable pump settings	7.0	32











Table 12



For a detailed description, refer to Service Booklet for the Engineer 7 181 465 347.

Displaying service functions



















All service functions are displayed.

- ▶ Press any button to activate the main menu.
- ▶ Press  or  button until the arrow cursor is pointing to **Settings**.
- ▶ Press the  button.
- ▶ Press  or  button until the arrow cursor is pointing to **Service**.
- ▶ Press the  button.
- ▶ Press the  button to select **Display service parameters**.
Service function **0.0, Last fault** is displayed.
- ▶ Press the  or  button to cycle through the current settings.
- ▶ Press the  button to exit the menu.

Setting service functions

Only the service functions that can be set are displayed.

- ▶ Press any button to activate the main menu.

- ▶ Press  or  button until the arrow cursor is pointing to **Settings**.
- ▶ Press the  button.
- ▶ Press  oder  button until the arrow cursor is pointing to **Service**.
- ▶ Press the  button.
The cursor is pointing to **Display service parameters**.
- ▶ Press and hold the  button (for about 5 seconds) until the display shows **Adjust service parameters** and the first service function to be set, e.g. **2.0, Operating mode**. If a fault has occurred, the display will show 0.0 and the last fault.
- ▶ Press the  or  button until the desired service function is displayed.
- ▶ Press the  button.
The first line of the display shows **Change value**.
- ▶ Use the  or  buttons to enter the required setting.
- ▶ Press the  button.
The text display shows **ATTENTION Store settings?**.
- ▶ Press  or  to select **yes** or **no**.
- ▶ Press  to confirm your selection.
The text display shows **Please wait**, and the service function is then displayed with the new setting.
- ▶ Press the  or  button until the next function you wish to change is displayed.

-or-

- ▶ Press the  button to exit the menu.

7.2.2 Setting the anti-cycle time (Service Function 2.4)

This service function is only active if Service Function 2.7, automatic anti-cycle time, is deactivated.

The anti-cycle time can be set to between 0 and 15 minutes (is factory set to 3 minutes).

If the setting 0 is entered, the anti-cycle time is inactive.

The shortest possible anti-cycle time is 1 minute (recommended for single-pipe and hot-air heating systems).



If the appliance is connected to an outside-temperature controlled heating programmer, the anti-cycle time does not need to be set on the appliance and is optimised by the programmer instead.

7.2.3 Setting the maximum CH flow temperature (Service Function 2.5)

The maximum CH flow temperature can be set to between 35°C and 88°C (factory setting).

7.2.4 Setting the heating output (Service Function 5.0)

The heating output can be set to any level between min. rated heat output and max rated heat output to limit it to the specific heat requirements.



The full rated heat output is still available for hot water or charging the hot water cylinder even if the heating output has been limited.

The factory setting is the max. rated heat output, 100 %.

- ▶ Look up heating output in kW and corresponding code number on the settings tables for heating output (see page 46).
- ▶ Enter the code number on the text display module.
- ▶ Measure the gas flow rate and compare with the figures specified for the code number shown. If different, correct code number.

7.2.5 Variable pump settings (Service Function 7.0)

The pump speed varies automatically to match the water flow requirement of the system determined by the position of thermostatic radiator valves. An automatic by-pass must not be used.

The Service Function 7.0 is factory set to 4 which will accommodate the majority of heating systems.

Information on the re-settings of this functions can be found in the Service Booklet for the Engineer number 7 181 465 347.

7.3 Setting the gas/air ratio

The appliance is set at the factory and adjustment is not necessary.

8 Converting the appliance to different gas types

The setting is factory sealed at maximum. Adjustment to the rated heat input and min. heat input is not necessary.

Checking the gas supply pressure

- ▶ Check the gas supply pressure at the gas supply pressure testing point.



Natural gas appliances must not be operated if the gas supply pressure is below 18 mbar or above 24 mbar.
LPG appliances must not be operated if the supply pressure is below or above 37 mbar.

Natural gas

- Appliances for **natural gas type G20** are factory set to Wobbe-Index 15 kWh/m³ and 20 mbar supply pressure and sealed.

Conversion kits

Model	For conversion from ...	Order no.
ZSBR 7-28	N.G to L.P.G	7 710 149 052
ZSBR 11-28	L.P.G to N.G	7 710 239 088

Table 13

- Instructions are sent with each conversion kit.

8.1 Setting the gas/air ratio

The gas/air ratio may only be adjusted on the basis of a CO₂ measurement at max. heat output and min. heat output using an electronic tester.

- ▶ Switch off the appliance at the master switch (O).
- ▶ Remove the outer case (see page 16, refer to fig. 15).
- ▶ Switch on the appliance at the master switch (I).
- ▶ Unscrew sealing plug from flue gas testing point (234). Refer to fig. 42.
- ▶ Insert testing probe about 135 mm into the flue gas testing point and seal testing point.

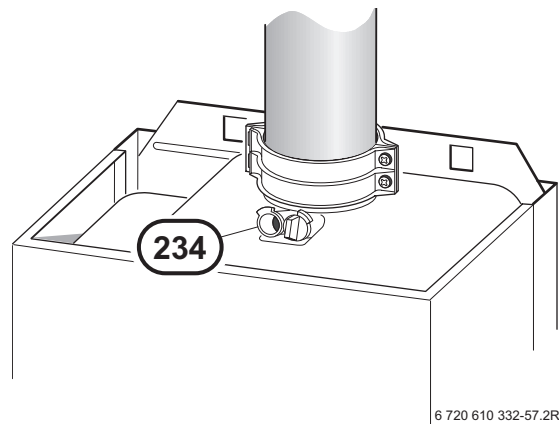

Fig. 42

- ▶ On the text display unit, select in the main menu **Settings, Service, Display service parameters**.
- ▶ Press and hold the button (for about 5 seconds) until the display shows **Adjust service parameters** and the first service function to be set, **2.0 Operating mode**. If a fault has occurred, the display will show 0.0 and the last fault.
- ▶ Press or until the display shows **2.0 Operating mode normal**.
- ▶ Press the button.
- ▶ Press or to select Max.
- ▶ Measure the CO₂ level.
- ▶ Prise off the seal on the gas flow restrictor.

- ▶ Adjust the gas flow restrictor (63) to obtain the CO₂ level given in Table 14. Refer to fig. 43.

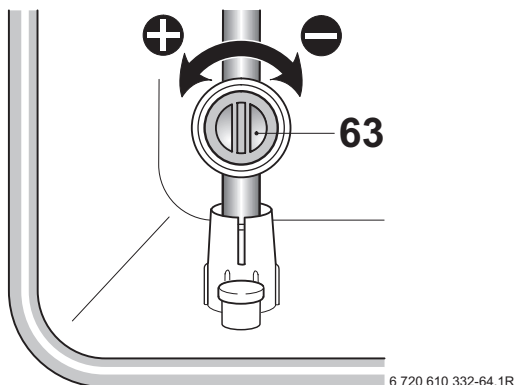



Fig. 43

- ▶ Remove testing probe from the flue gas testing point (234) and refit sealing plug.
- ▶ Re-seal gas valve adjusting screw and gas flow restrictor.
- ▶ Replace the outer case by locating it on the top lugs and pushing backwards until the bottom clips are fully engaged. Check that the case is properly aligned with fascia. Refer to fig. 15.
- ▶ Secure by replacing the screw at the bottom left. Refer to fig. 15.

ZSBR 7-28		
Gas Type	CO ₂ reading at max. rated heat output	CO ₂ reading at min. rated heat output
Natural gas type G20	9.2 %	8.8 %
LPG G31 (propane)	10.8 %	10.5 %

Table 14

- ▶ Press  or  to select Min.
- ▶ Measure the CO₂ level.
- ▶ Remove the seal from the gas valve adjusting screw (64) and adjust the CO₂ level to the figure given in Table 14 for min. rated heat output. Refer to fig. 44.

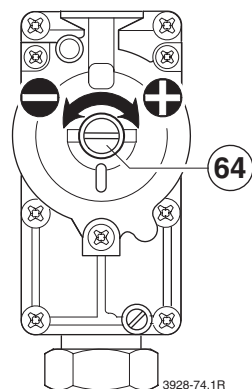









Fig. 44

- ▶ Recheck the levels at min. and max. rated heat output and re-adjust if necessary.
- ▶ Press  or  until the display shows **normal**.
- ▶ Press the  button. The text display shows **Store settings**.
- ▶ Press  to select **yes**.
- ▶ Press the  button.

8.2 Testing combustion air/flue gas at set heat output

8.2.1 Testing the O₂ or CO₂ level in the combustion air

i By testing the O₂ or CO₂ level in the combustion air the gas tightness of a type C₁₃ or C₃₃ **flue system** can be checked. The O₂ level must not be less than 20,6 %. The CO₂ level must not exceed 0,2 %.

- ▶ Press and hold the  button until the display shows --. "Chimney sweep" mode is now active. The  button will light up and the display shows the CH flow temperature.

i In "chimney sweep" mode, the appliance switches to max. rated heat output or the set heating output. You then have 15 minutes in which to measure the levels. After that, the appliance switches back from "chimney sweep" mode to normal mode.

- ▶ Remove sealing plug from combustion air testing point (234.1, fig. 45).
- ▶ Insert testing probe about 80 mm into the testing point and seal testing point.

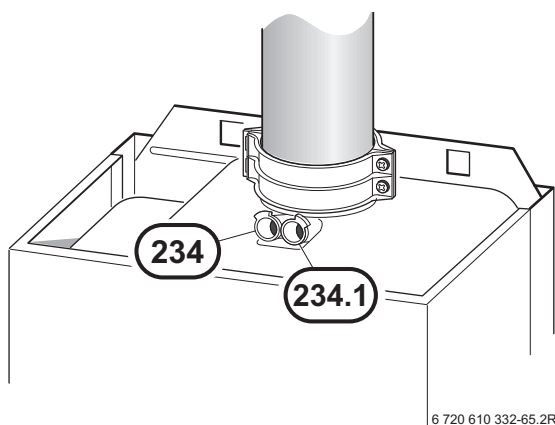







Fig. 45

- ▶ Measure O₂ and CO₂ levels.
- ▶ Refit sealing plug.
- ▶ Press and hold  button until the display shows --. The  button will stop flashing and the display shows the CH flow temperature.

8.2.2 Testing CO and CO₂

- ▶ Press and hold the  button until the display shows --. "Chimney sweep" mode is now active. The  button will light up and the display shows the CH flow temperature.

i You have 15 minutes in which to measure the levels. After that, the appliance switches back from "chimney sweep" mode to normal mode.

- ▶ Remove sealing plug from flue gas testing point (234, fig. 45).
- ▶ Insert testing probe about 135 mm into the testing point and seal testing point.
- ▶ CO- and CO₂ levels.
- ▶ Refit sealing plug.
- ▶ Press and hold  button until the display shows --. The  button will stop flashing and the display shows the CH flow temperature.

9 Maintenance



- ▶ Always disconnect the appliance from the electrical power supply (fuse, circuit breaker) before carrying out any work on the electrical systems or components.



- ▶ Always turn off the gas cock before carrying out any work on components which carry gas.



There is a Service booklet for the Engineer, order no. 7 181 465 347, available to competent persons.



All safety and control systems are monitored by the Bosch Heatronic. In the event of a component fault, the textdisplay shows a fault code.

- ▶ The User should be recommended to have the appliance serviced regularly by a competent person.
- ▶ Use only genuine spare parts
- ▶ Refer to the Spare Parts List when ordering spare parts.
- ▶ Always renew seals and O-rings removed during servicing or repair work.
- ▶ Use only the following types of grease:
 - Water valve: WRAS approved silicon based grease
 - Unions: approved sealant.
- ▶ To drain the appliance shut the system valves and open the pressure relief valve.
- ▶ Upon completion of any electrical work check for earth continuity, correct polarisation and resistance to earth.

Replace the text display module or the Heatronic PCB

If the text display module is replaced, the service function settings are retained.

- ▶ The remaining settings have to be re-entered.

If the Heatronic PCB is replaced:

- ▶ Re-enter the service function settings as recorded in the commissioning record.

9.1 Pre-Service Check List

		Date							
1	Call up the last fault stored by the text-display , (see page 30).								
2	Check ionisation current, Service Function 3.3 , (see page 38).								
3	Perform visual check of air/flue duct. Visual check of diaphragm for soiling and splits (see page 40).								
4	Check gas supply pressure (see page 33).	mbar							
5	Test combustion air/flue gas (see page 35).								
6	Check CO ₂ setting for min./max. (gas/air ratio) (see page 35).	min. % max. %							
7	Check gas and water systems for leaks (see page 16).								
8	Check heat exchanger (see page 38).	mbar							
9	Check burner (see page 39).								
10	Clean condensation trap (see page 39).								
11	Check charge pressure of expansion vessel matches static head of heating system.	mbar							
12	Check central heating system pressure.	mbar							
13	Check electrical wiring for damage.								
14	Check heating programmer settings in the textdisplay.								
15	Check appliances that are part of the heating system.								

Table 15

9.2 Description of servicing operations

The combustion performance must be checked before and after any servicing work on the combustion and burner components. Refer to section 8.2.

Checking the ionisation current, Service Function 3.3

- ▶ Select Service Function **3.3**. (See page 31 “Displaying Service Functions”)

If the display shows 2 or 3, the ionisation current is OK. If the display shows 0 or 1, the electrode assembly (32.1, page 6) must be cleaned or replaced.

Primary Heat exchanger

There is a special accessory kit (no. 840) for cleaning the heat exchanger, order no. 7 719 001 996.

- ▶ Check control pressure on the air - gas mixer unit at max. rated heat output using an electronic manometer.

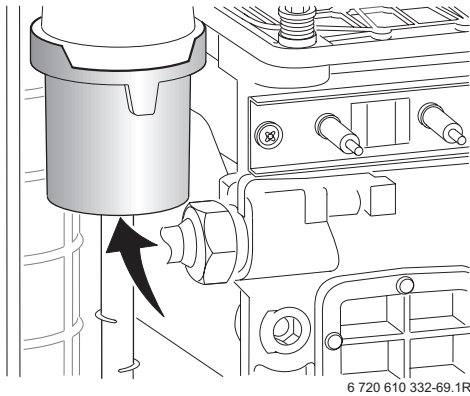

Fig. 46



The heat exchanger should only be cleaned if the control pressure is **2.2 mbar** (depression) or less.

- ▶ Remove cleaning access cover (415, page 6) and the metal plate below it, if present. Refer to fig. 2.
- ▶ Unscrew condensation trap and place suitable container underneath. Refer to fig. 47.

- ▶ Remove the fan and the burner as described in the text headed “Burner” (see page 39).

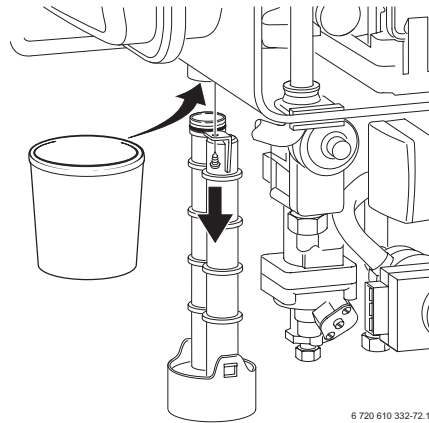

Fig. 47

- ▶ Loosen any deposits in the heat exchanger from top to bottom using the cleaning blade. Refer to fig. 48.

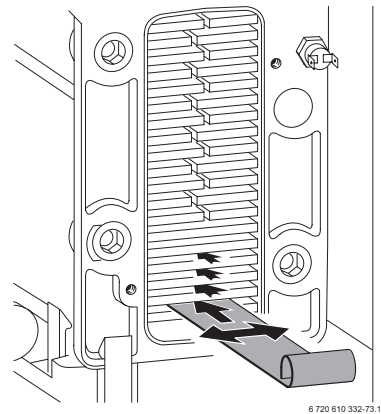

Fig. 48

- ▶ Clean the heat exchanger from top to bottom using the brush. Refer to fig. 49.

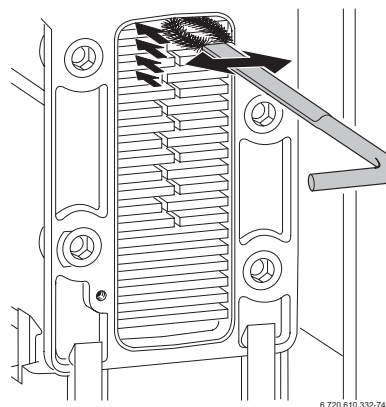

Fig. 49

- ▶ Flush the heat exchanger from the top. Refer to fig. 50.

- ▶ Clean out the condensate collector and trap connection (with other end of brush).

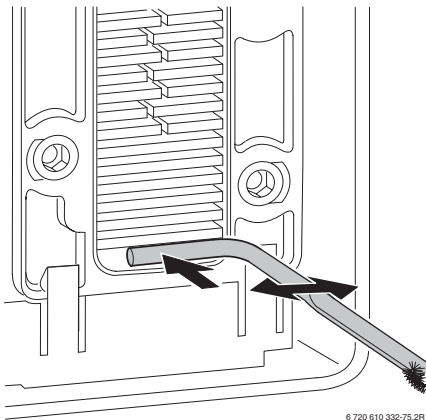

Fig. 50

- ▶ Refit the clean-out cover using a new seal and tighten screws to torque of approx. 5 Nm.

Burner

- ▶ Check that the gas cock is turned off and the master switch is in the OFF position.
- ▶ Remove the clips (1.) and unscrew the two bolts (2.). Refer to fig. 51.
- ▶ Unscrew and remove the two hexagon screws securing the fan (3.).
- ▶ Slacken fully the rear securing bolt (4.).
- ▶ Remove the burner coverplate.

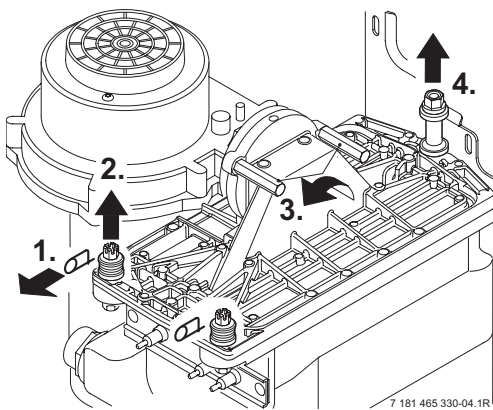

Fig. 51

- ▶ Remove the burner skin and clean components. Do not use a wire brush. Refer to fig. 52.

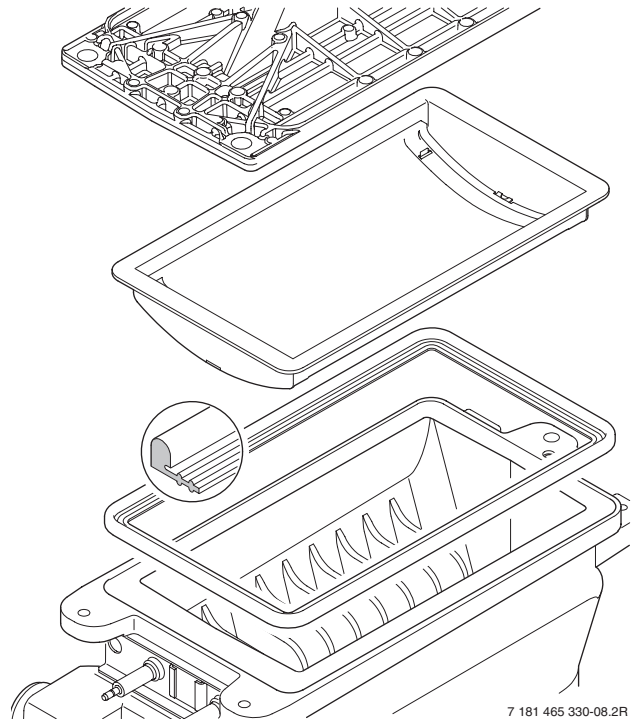

Fig. 52

- ▶ Re-assemble burner in reverse order using a new seal.
- ▶ Adjust gas/air ratio (see page 33). Refer to section 8.2.

Condensation trap

In order to prevent spillage of condensate the condensation trap should be completely removed, (see page 38, fig. 47).

- ▶ Unscrew condensation trap and check connection to heat exchanger is clear.
- ▶ Remove condensation trap cover and clean.
- ▶ Fill condensation trap with approx. 1/4 l of water and refit.

Electrode assembly

- ▶ Switch off the master switch.
- ▶ Pull off the leads from the electrodes. Refer to fig. 2.
- ▶ Unscrew the two fixing screws and carefully remove the electrode assembly. Refer to fig. 46.
- ▶ Clean the electrodes with a non-metallic brush. (The spark gap should be $4,5 \text{ mm} \pm 0,5 \text{ mm}$.)
- ▶ Replace and re-connect the assembly taking care not to mislay the inspection window.

Diaphragm in mixer unit



- ▶ Take care not to damage diaphragm (443) when removing and refitting it.

- ▶ Open mixer unit (29).
- ▶ Carefully withdraw diaphragm (443) from fan intake tube and check for soiling and splits.

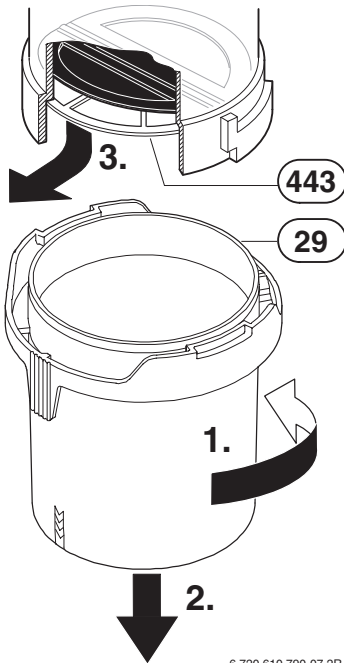

6 720 610 790-07.2R

Fig. 53

- ▶ Carefully refit diaphragm (443) the correct way round into the fan intake tube.



The flaps of the diaphragm (443) must open upwards.

- ▶ Seal the mixer unit (29).

Siphon

- ▶ Unscrew the clip and disconnect the pipe to the siphon.
- ▶ Remove the yellow plug to drain the siphon.
- ▶ Unscrew the securing nut from beneath the side facia and remove the siphon. Refer to figure below.

- ▶ Refit and prime the siphon.

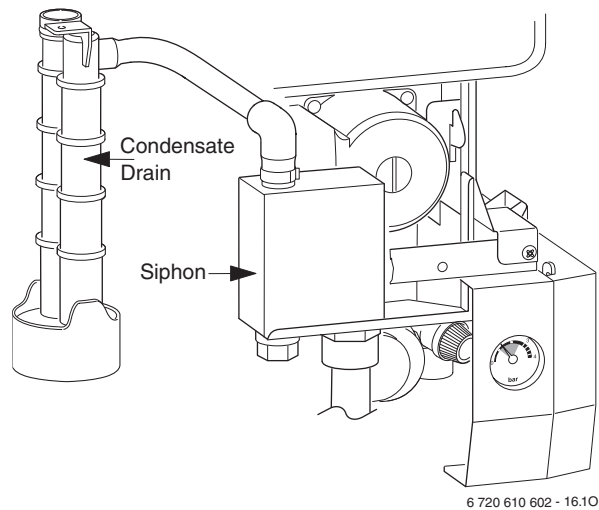

6 720 610 602 - 16.10

Fig. 54

Expansion vessel

The expansion vessel should be checked once a year.

- ▶ Depressurise appliance.
- ▶ If necessary, adjust expansion vessel charge pressure to static head of the heating system.

Heating system pressure



Fill the system using the WRAS approved filling loop.

- ▶ The pointer on the pressure gauge should be 1 bar.
- ▶ If the pointer is below 1 bar (when the system is cold), water should be added until the pointer is 1 bar again.
- ▶ **Max. pressure** of 2.5 bar when the heating system water is at maximum temperature must not be exceeded. If this pressure is exceeded then an extra expansion vessel must be fitted in the system return as close to the appliance as possible.
- ▶ If the system does not retain the pressure, the expansion vessel and the heating system should be checked for leaks.

9.3 Replacement of Parts

Before changing any components check that the gas is turned off and that the appliance is electrically isolated. When necessary close the system valves and drain the appliance.

Refitting is a reverse of the procedure for removal using new seals or o-rings as appropriate.

9.3.1 PCB control board and transformer

- ▶ Switch off the appliance.
- ▶ Disconnect appliance from the power supply.
- ▶ Unplug all connectors from the control box (inc. keyed plug). Access is gained by removing the covers. Refer to fig. 27, 28.
- ▶ Remove screw holding power connector earth lead and remove earth lead.
- ▶ Remove two top fixing screws from the control box. Refer to fig. 55.

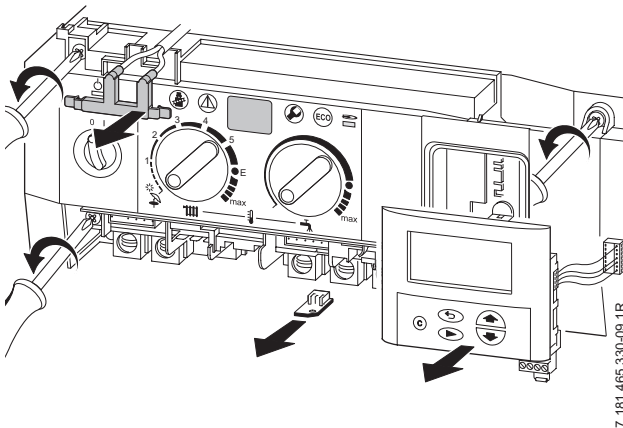

Fig. 55

- ▶ Lower the control box.
- ▶ Unscrew earth lead.
- ▶ Unscrew four fixing screws from cover plate. Refer to fig. 56.
- ▶ Prise off cover plate.
- ▶ Pull off transformer.
- ▶ Remove pcb holder.

- ▶ Remove the pcb control board.

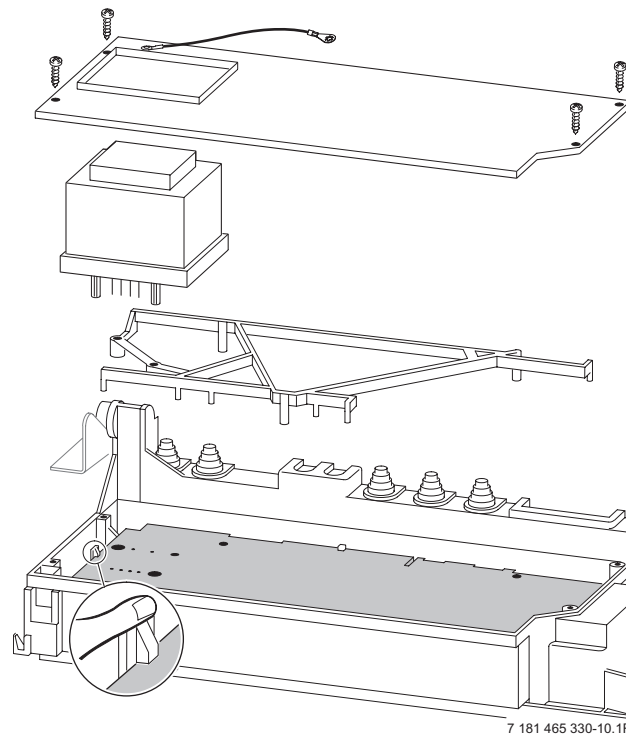

Fig. 56

Fuses

- ▶ Remove the connections covers. Refer to fig. 27, 28.

The fuses are located adjacent to the mains connector block and connector ST18. Refer to fig. 4.

Fuse, item 312, is only replaceable by removing the pcb.

Spare fuses are fixed to the connections cover.

A fuse pack is available: Part number 8 744 503 010 0.

9.3.2 Fan Assembly

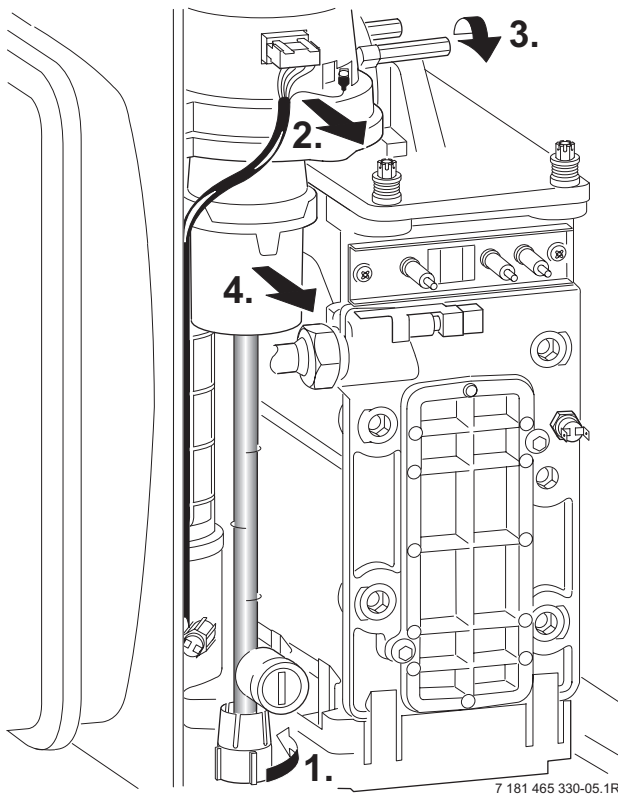

Fig. 57

- ▶ Switch off the appliance.
- ▶ Disconnect the appliance from the power supply.
- ▶ Undo lower pipe union on gas pipe (1.). Refer to fig. 57.
- ▶ Remove fan lead and earth connector (2.). The earth connector has a positive clip fixing.
- ▶ Remove fixing screws attaching fan to the burner cover (3.).
- ▶ Remove fan together with gas pipe and mixer unit.
- ▶ Separate the fan from the pipe and mixer unit by twisting the mixer unit to release it (4.).

9.3.3 Pump

- ▶ Switch off the appliance.
- ▶ Disconnect the appliance from the power supply.
- ▶ Remove two switchbox fixing screws (1.). Refer to fig. 58.
- ▶ Lower switchbox (2.).
- ▶ Remove screw from underside of right-hand plastic cover plate (3.).
- ▶ Pull cover plate forwards to remove (4.).
- ▶ Unscrew and remove the the siphon by releasing the jubilee clip. Refer to fig. 54.
- ▶ Unscrew the pump union nuts (5.). Refer to fig. 58.
- ▶ Carefully remove the pump and disconnect the leads.

Alternatively

- ▶ After removing the siphon release the four Allen screws and remove and replace the pump head.

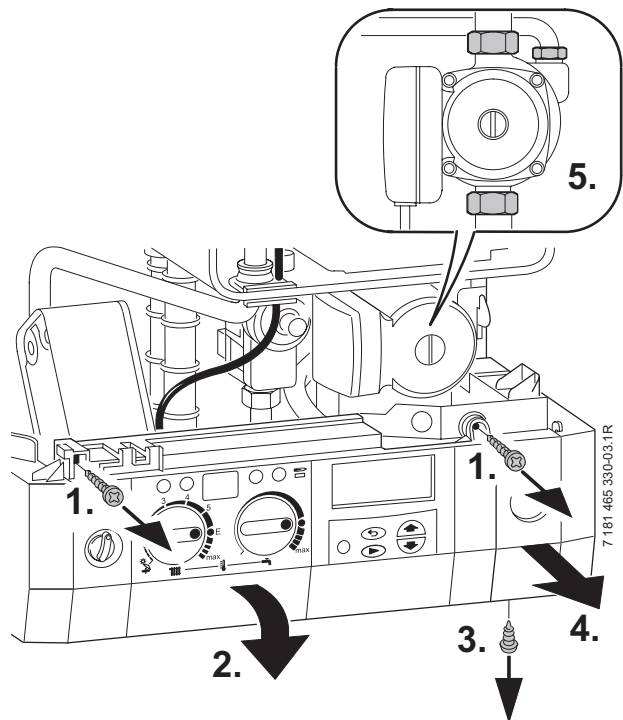
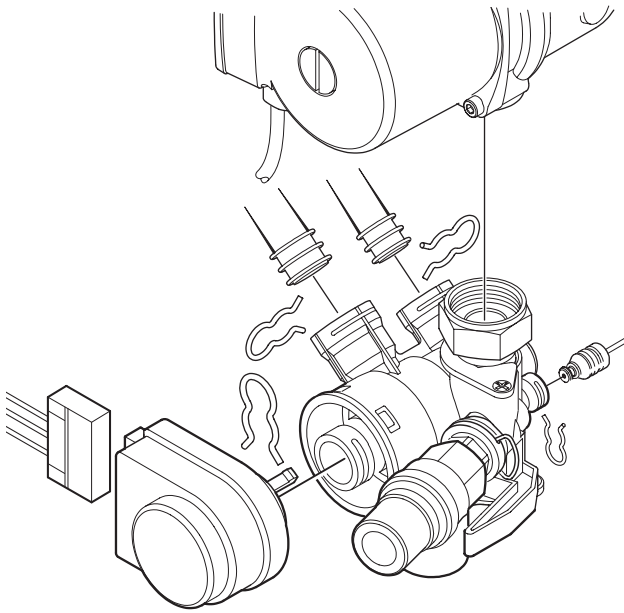

Fig. 58

9.3.4 3-way diverter valve

- ▶ Switch off the appliance.
- ▶ Disconnect appliance from the power supply.
- ▶ Turn off service cocks.
- ▶ Unplug connector from 3-way valve motor. Refer to fig. 59.
- ▶ Pull out retaining clip.
- ▶ Remove motor.
- ▶ Disconnect the relief valve drain.
- ▶ Disconnect the pressure gauge by withdrawing the clip and pulling out the capillary head.

- ▶ Undo pipe unions by withdrawing the clips.
- ▶ Remove 3-way valve.



7 181 465 330-12.1R

Fig. 59

After refitting:

- ▶ Fill system, bleed and re-pressurise (see Installation Instructions).

9.3.5 3-way diverter valve motor

- ▶ Switch off the appliance.
- ▶ Turn off the service cocks.
- ▶ Unplug connector from 3-way valve motor. Refer to fig. 59.
- ▶ Pull out retaining clip.
- ▶ Remove motor.

9.3.6 Sensors

- ▶ Check that the appliance is electrically isolated.

Central Heating Flow Temperature Sensor – Item 36, fig. 2, 55

- ▶ Pull-off the connector.
- ▶ Release the sensor clip and withdraw the sensor.
- ▶ Apply heat transfer paste to the replacement sensor.

Safety Temperature Limiter – Item 6, fig. 2, 55

- ▶ Pull-off the connectors.
- ▶ Unscrew the sensor.

Flue Temperature Limiter – Item 9, fig. 2, 55

- ▶ Pull-off the connectors.
- ▶ Unscrew the sensor.

9.3.7 Gas Valve

- ▶ Check that the gas cock is turned off.
- ▶ Lower the control panel. Refer to fig. 58.
- ▶ Pull off the solenoid connections at the rear of the valve.
- ▶ Undo the union, within the inner casing, securing the valve to the gas/air tube. Refer to fig. 57.
- ▶ Remove the white plastic cap from the gas valve.
- ▶ Release the gas inlet union at the manifold assembly.
- ▶ Unscrew the two screws securing the gas valve assembly bracket to the back panel and withdraw the assembly.
- ▶ Transfer the bracket and inlet pipe assembly to the new gas valve.
- ▶ Check for gas soundness when the new gas valve has been fitted.
- ▶ Recheck the combustion performance as described in section 8.1.

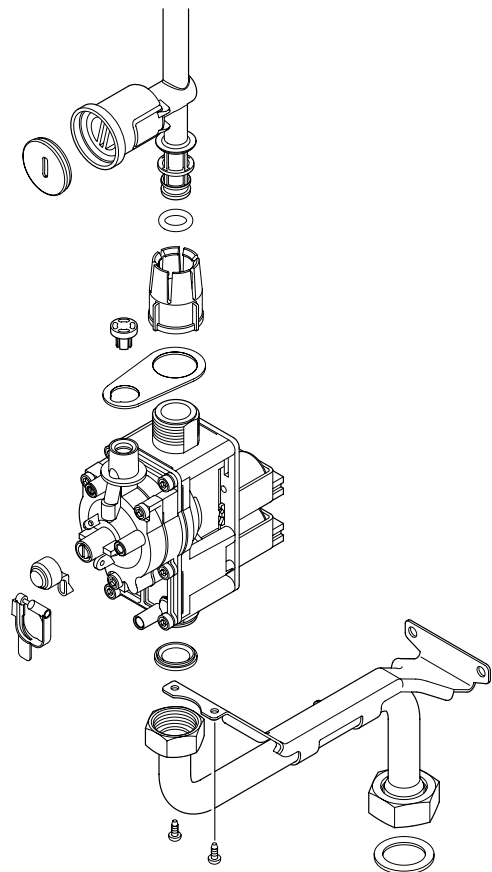

6 720 610 602 - 04.10

Fig. 60

9.3.8 Electrode assembly

- ▶ Refer to section 9.2.
- ▶ Use a new seal if the existing seal is damaged.

9.3.9 Pressure gauge

- ▶ Drain the appliance.
- ▶ Lower the facia. Refer to fig. 58.
- ▶ Twist the pressure gauge head anti-clockwise to release it from the casing. Refer to fig. 2.
- ▶ Disconnect the capillary head from the rear of the diverter valve by withdrawing the clip and pulling out the head. Refer to fig. 59.

9.3.10 Expansion vessel

- ▶ Drain the appliance.
- ▶ Undo the union connection at the base of the vessel. Refer to fig. 2.
- ▶ Unscrew the top and bottom fixing screws and remove the vessel.
- ▶ Set the pressure of the new vessel to that required by the system.

9.3.11 Pressure Relief Valve

- ▶ Drain the appliance.
- ▶ Disconnect the drain pipe from the valve. Refer to fig. 33.
- ▶ Pull-out the clip securing the valve.
- ▶ Pull-out the valve.
- ▶ Ensure that the replacement valve is fully entered before fitting the clip.

9.3.12 Burner

- ▶ Refer to section 9.2.

9.3.13 Primary Heat Exchanger

- ▶ Drain the appliance.
- ▶ Check that the gas supply is turned off.
- ▶ Check that the appliance is electrically isolated.
- ▶ Remove the fan assembly complete with the gas/air tube and mixer assembly. Refer to section 9.3.2.
- ▶ Remove the burner. Refer to section 9.2.
- ▶ Disconnect the sensors. Refer to section 9.3.6.
- ▶ Undo the central heating flow union.
- ▶ Undo the top connection of the pump. Refer to fig. 57.
- ▶ Undo the grey plastic cap, next to the top pump connection at the base of the heat exchanger.
- ▶ Unscrew and remove the condensate trap. Refer to section 9.2.
- ▶ Unscrew and remove the two screws securing the heat exchanger top bracket to the rear panel.
- ▶ Lift up the flue duct, item 271, refer to fig. 2.

- ▶ Pull forward from the top and lift the heat exchanger from the casing.
- ▶ Transfer components, as necessary, to the new heat exchanger.
- ▶ Ensure that all the seals are in place and all of the connections are tight before re-commissioning the appliance.

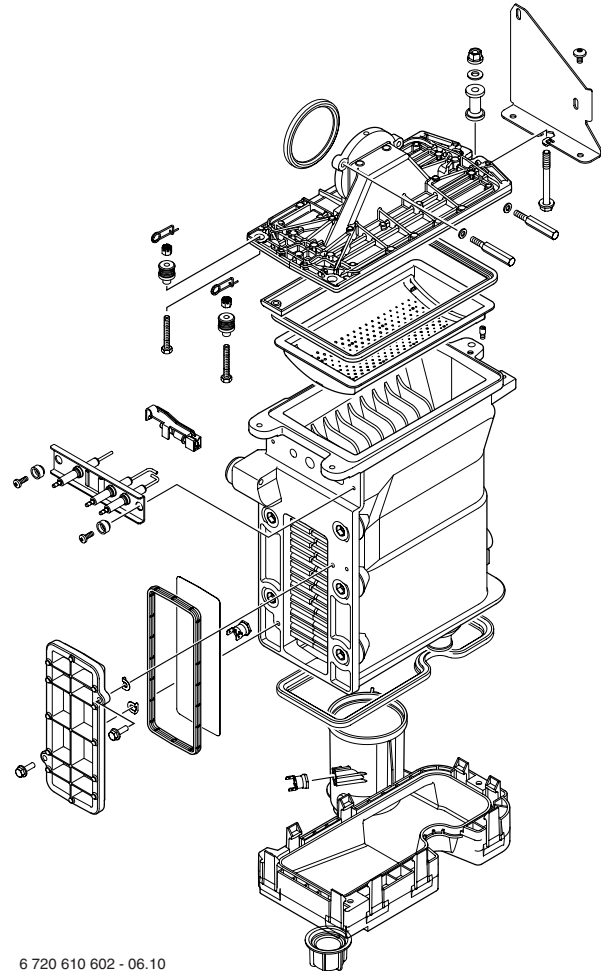

Fig. 61

10 Appendix

10.1 Fault Codes

More detailed fault finding procedures are described in the Service Booklet for the Engineer number 7 181 465 347.

Display code	Description	Remedy
A1	Pump has run dry	Check system pressure, add water and bleed system as necessary
A8	Break in communication	Check connecting lead to TR2
b1	Keyed plug not detected.	Insert keyed plug correctly, test and replace if necessary.
C1	Fan speed too low.	Check fan lead and connector, and fan; replace as necessary.
d3	Jumper 8-9 not detected.	Connector not connected, link missing, underfloor heating limiter tripped.
E2	CH flow NTC sensor defective	Check CH flow NTC sensor and connecting lead.
E9	Safety temp. limiter in CH flow has tripped.	Check system pressure, check safety temp. limiters, check pump operation, check fuse on pcb, bleed appliance.
EA	Flame not detected.	Is gas cock turned on? Check gas supply pressure, power supply, igniter electrode and lead, ionisation sensing electrode and lead, flue duct and CO2 level.
F0	Internal error.	Check electrical connector contacts, programmer interface module ignition leads and bus module are not loose; replace pcb or bus module if necessary.
F7	Flame detected even though appliance switched off.	Check electrode assembly, dry pcb. Flue clear?
FA	Flame detected after gas shut off.	Check gas valve and wiring to gas valve. Clean condensation trap and check electrode assembly. Flue clear?
FC	Textdisplay not detected.	Check connecting lead between Textdisplay and Heatronic, change Textdisplay
Fd	Reset button pressed by mistake.	Press reset button again
P1, P2, P3, P1...	Please wait, initialisation in progress.	24 V fuse blown. Replace fuse.

Table 16

10.2 Short parts list

Key	Description	Qty GC	Spare part number
1	Sensor - Flue gas temp.	1	8 729 000 144 0
2	Sensor - CH flow temp.	1	8 714 500 087 0
3	Control board	1	8 748 300 418 0
4	Gas valve	1	8 747 003 516 0
5	Fan assembly	1	8 717 204 373 0
6	Fan washer	1	8 729 000 183 0
7	Expansion vessel	1	8 715 407 236 0
8	Relief valve	1	8 717 401 012 0
9	Electrode assembly	1	8 718 107 077 0
10	Electrode lead	1	8 714 401 999 0
11	Pump	1	8 717 204 477 0
12	Pressure gauge	1	8 717 208 079 0
13	Burner skin seal	1	8 711 004 168 0
14	Transformer - facia	1	8 747 201 358 0
15	Flow switch	1	8 717 002 110 0
16	3-way diverter valve	1	8 717 010 062 0
17	Heat exchanger washer	1	8 710 103 153 0
18	Washer set Condensation Trap	1	8 710 103 154 0
19	Fuse set	1	8 744 503 010 0
20	Service set Water Valve	1	8 710 503 031 0
21	Text Display	1	8 747 208 103 0
22	Primary heat exchanger	1	8 715 406 615 0
23	Diaphragm	1	8 715 505 801 0

Table 17

10.3 Heating/hot water output settings ZSBR 7-28 N.G.

Display code	Heat output, kW	Heat input, kW	Natural gas G20 Gas vol. flow rate (l/min at $t_V/t_R = 80/60^\circ\text{C}$)
30	8.2	8.3	14.5
40	11.0	11.1	19.4
50	13.7	13.9	24.2
60	16.4	16.6	29.1
70	19.2	19.4	33.9
80	21.9	22.2	38.8
90	24.7	24.9	43.6
100	27.4	27.7	48.5

Table 18

10.4 Heating/hot water output settings ZSBR 11-28 L.P.G

Display code	Propane	
	Heat output kW	Heat input kW
40	11.0	11.1
50	13.7	13.9
60	16.4	16.6
70	19.2	19.4
80	21.9	22.2
90	24.7	24.9
100	27.4	27.7

Table 19

10.5 Operational Flow diagrams

10.5.1 Central heating function

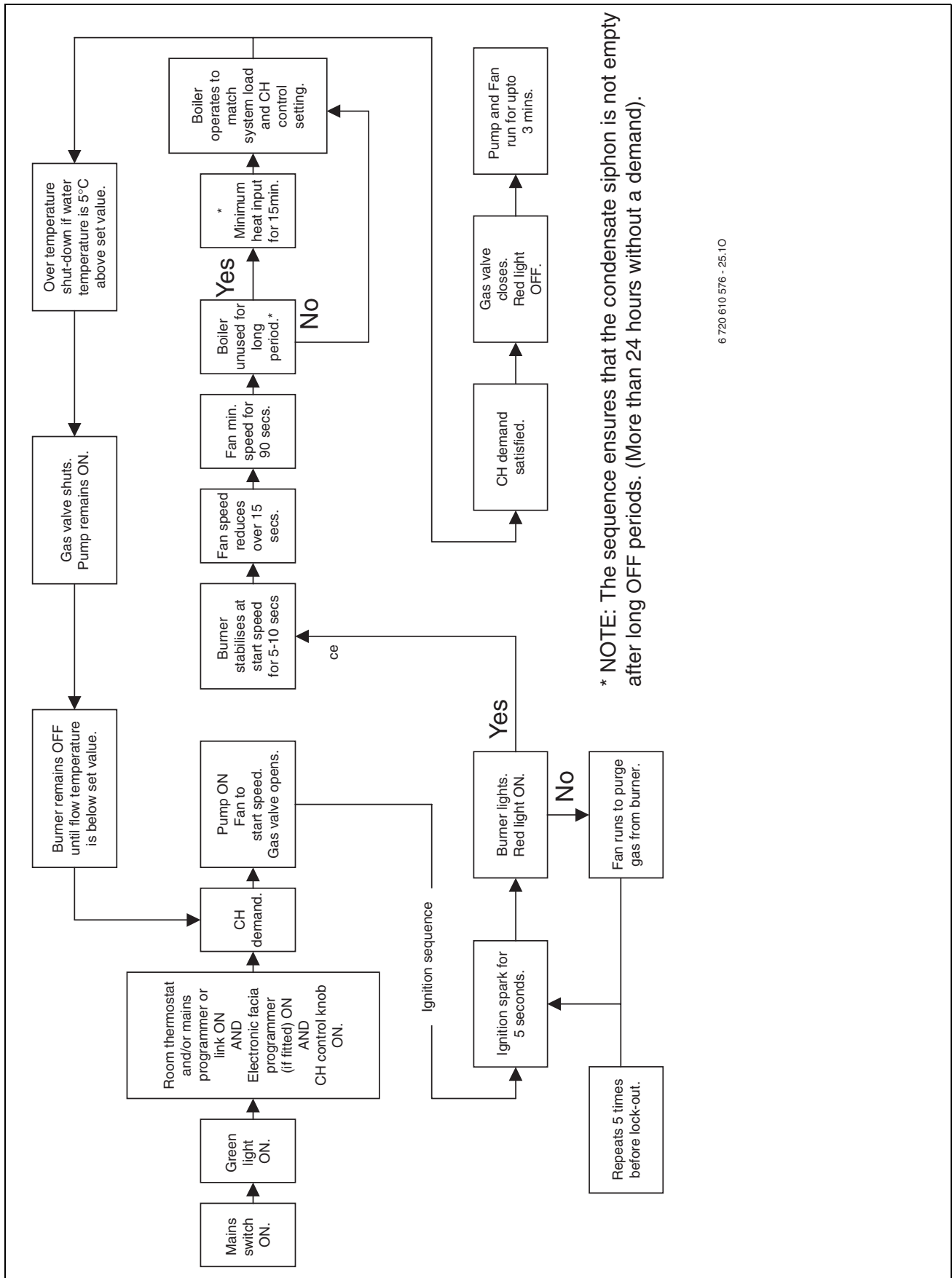
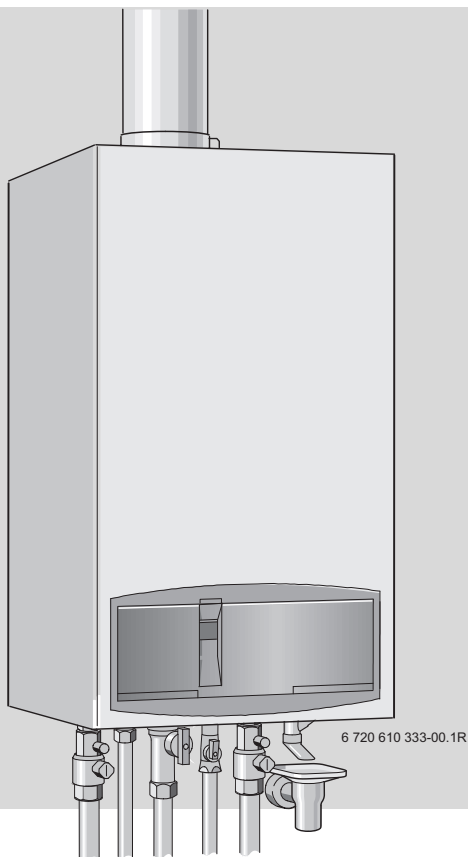

Fig. 62

EXCELLENCE COMES AS STANDARD
Manufactured exclusively for British Gas by The Bosch Group
Bosch Group, Worcester Heat Systems, Cotswold Way, Warndon, Worcester WR4 9SW.
Telephone: (01905) 754624 Fax: (01905) 754619

Service Booklet for the Engineer for Gas Condensing Boilers



- ZSBR 7-28 ICS1** GC-Number: 41 108 04
- ZWBR 8-30 ICC2** GC-Number: 41 108 09
- ZBR 8-35 ICS1** GC-Number: 41 108 05
- ZWBR 11-37 ICC1** GC-Number: 41 108 10
- ZWBR 7-28 HE plus** GC-Number: 47 311 56
- ZWBR 11-35 HE plus** GC-Number: 47 311 57

Contents

Safety precautions	3
<hr/>	
Symbols	3
<hr/>	
1 Layout of Appliance (ZSBR/ZWBR)	4
<hr/>	
2 Operation	5
2.1 Standard display	5
2.2 Displaying service functions	5
2.3 Setting service functions	5
2.4 Resetting service functions to factory settings	5
2.4.1 Resetting service functions 0.0 to 4.9 to their factory settings (Reset 1):	5
2.4.2 Resetting service functions 0.0 to 9.9 to the factory setting (Reset 2):	5
<hr/>	
3 Boiler service functions	6
3.1 Summary	6
3.2 Explanation of service functions	9
<hr/>	
4 Rectifying faults	14
4.1 Boiler failure codes indication	14
4.1.1 ... on the boiler	14
4.1.2 ... on the programmer (optional accessory)	14
4.2 Summary	14
4.2.1 Appliance faults	14
4.2.2 Faults that are not indicated on any display	14
4.3 How to use the fault tables	16
4.4 Faults indicated on display	17
4.5 Faults that are not displayed	36
4.5.1 Appliance faults	36
4.5.2 Programmer faults	41
<hr/>	
5 Appendix	45
5.1 NTC values	45
5.1.1 Outside temperature sensor	45
5.1.2 CH flow NTC sensor, heat store NTC sensor, constant hot water NTC sensor and hot water NTC sensor	45
5.2 Electronic schemes	46
5.3 List of most important replacement parts	47
5.4 Approved corrosion inhibitors and anti-freeze fluids for central heating water	48
5.5 Detecting corrosion by CFCs	49

Safety precautions

Repairs

- ▶ Repairs may only be carried out by an approved installer!
- ▶ Before carrying out any work on the appliance, switch it off at the master switch!
- ▶ Even when the appliance is switched off at the master switch, some components on the PCB control board inside the control box are still live. Therefore:
 - ▶ Before carrying out any work on the electrical parts of the appliance fully disconnect it from the power supply (e. g. by means of fuse or circuit breaker)!
- ▶ Flue ducting must not be modified in any way.
- ▶ Use only original spare parts!

Instructions to the customer

- ▶ Advise the customer that he/she must not make any modifications to the appliance or carry out any repairs on it.
- ▶ Draw attention to the need for an annual service (or maintenance contract if applicable).



Symbols



Safety instructions in this document are identified by a warning-triangle symbol and are printed on a grey background.

Signal words indicate the seriousness of the hazard in terms of the consequences of not following the safety instructions.

- **Caution** indicates that minor damage to property could result.
- **Warning** indicates that minor personal injury or serious damage to property could result.
- **Danger** indicates that serious personal injury could result. In particularly serious cases, lives could be at risk.



Notes are identified by the symbol shown on the left. They are bordered by horizontal lines above and below the text

Notes contain important information in cases where there is no risk of personal injury or damage to property.

1 Layout of Appliance (ZSBR/ZWBR)

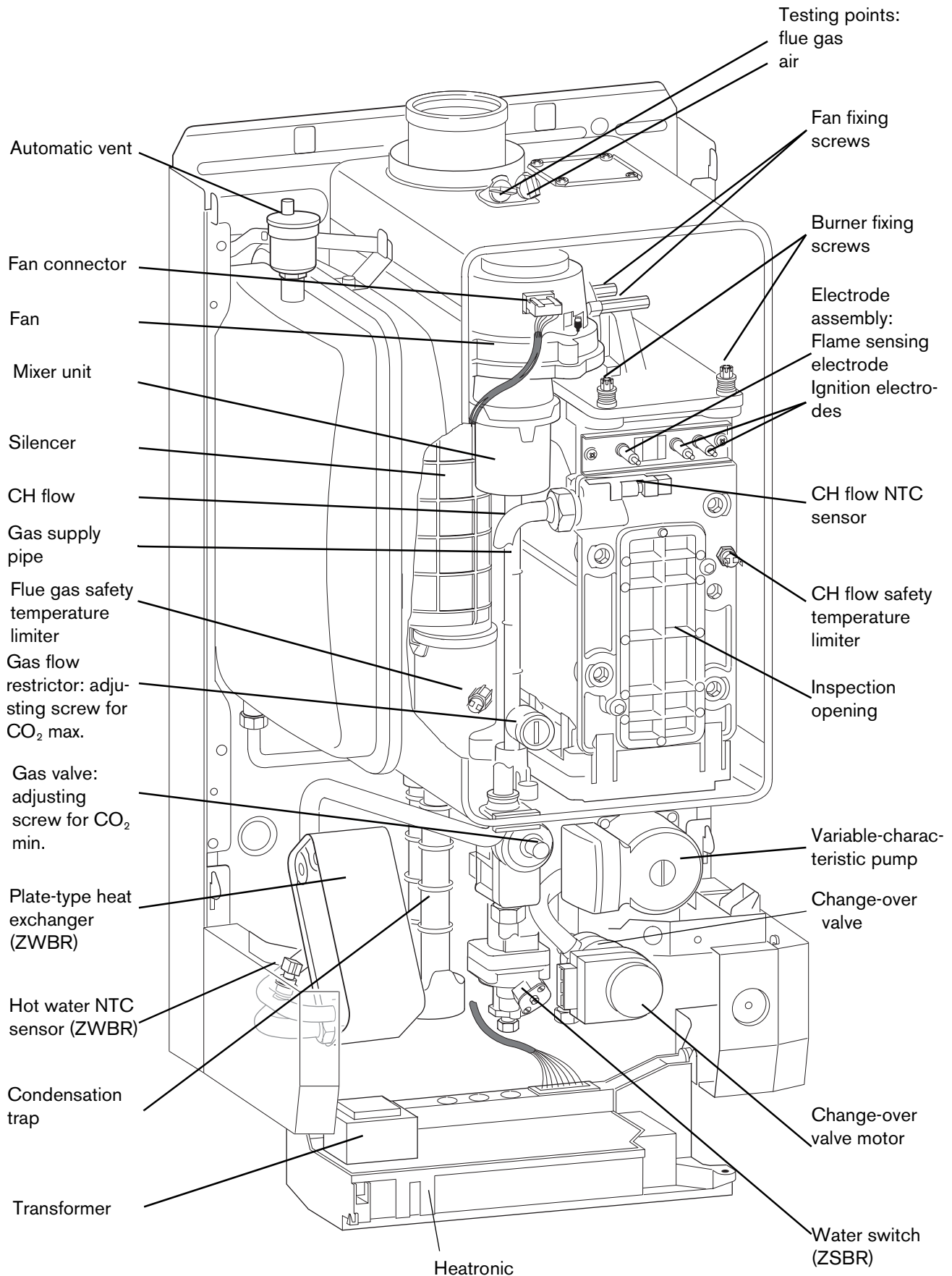

2 Operation

Instructions on the use of the text display module are given in the operating and installation instructions for the boiler.

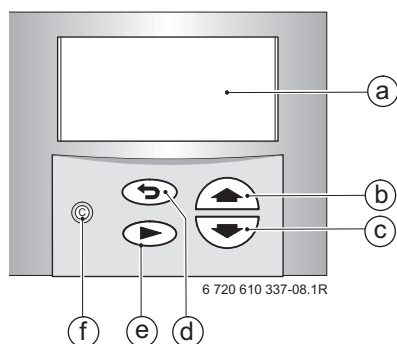

Fig. 1 Controls

- a Display
- b "Up" or "More" button
- c "Down", or "Less" button
- d "Back" button
- e "Nest" button
- f "Delete" button

2.1 Standard display

The text display shows the time, the CH flow temperature and the measured outside temperature in plain English.

In addition, the 2-digit display also shows the current CH flow temperature in Heating mode and Hot Water mode (display range 00 °C to 99 °C).

2.2 Displaying service functions

- ▶ Press any button to activate the main menu.
- ▶ Press or button until the arrow cursor is pointing to **Settings**.
- ▶ Press the button.
- ▶ Press or button until the arrow cursor is pointing to **Service**.
- ▶ Press the button.
- ▶ Press button to select **Display service parameters**.
Service function 0.0, Last fault is displayed.
- ▶ Press or button to cycle through the current settings.
- ▶ Press button to exit the menu.

2.3 Setting service functions

- ▶ Press any button to activate the main menu.
- ▶ Press or button until the arrow cursor is pointing to **Settings**.
- ▶ Press the button.
- ▶ Press or button until the arrow cursor is pointing to **Service**.

- ▶ Press the button.
The cursor is pointing to **Display service parameters**.
- ▶ Press and hold the button (for about 5 seconds) until the display shows **Adjust service parameters** and the first service function to be set, e.g. **2.0, Operating mode**. If a fault has occurred, the display will show 0.0 and the last fault.
- ▶ Press or button until the desired service function is displayed.
- ▶ Press the button.
The first line of the display shows **Change value**.
- ▶ Use the and buttons to enter the required setting.
- ▶ Press the button.
The text display shows **ATTENTION Store settings?**
- ▶ Press or to select **yes** or **no**.
- ▶ Press to confirm your selection.
The text display shows **Please wait ...**, and the service function is then displayed with the new setting.
- ▶ Press the or button until the next function you wish to change is displayed.

-or-

- ▶ Press the button to exit the menu.

2.4 Resetting service functions to factory settings

2.4.1 Resetting service functions 0.0 to 4.9 to their factory settings (Reset 1):

- ▶ Power OFF the appliance.
- ▶ Press the button and keep it pressed.
- ▶ Switch on the appliance, press and hold the button until the display shows r1 followed by [] .

2.4.2 Resetting service functions 0.0 to 9.9 to the factory setting (Reset 2):

- ▶ Power OFF the appliance.
- ▶ Simultaneously press and hold buttons and .
- ▶ Switch on appliance, press and hold the and buttons until the display shows r2 followed by [] .



To reset all parameters (except service settings) set on the text display module):

- ▶ Press and hold the button until the settings are deleted.

3 Boiler service functions

3.1 Summary

	Text display message	Display	Range adjustable from - to	Reset Value
0.0	Last fault	00 - FF	Clear only	0
0.1	Flow temp. sensor	0 - 99 °C	-	-
0.2	Hot water temp. sensor	0 - 99 °C	-	-
0.3	Stor. tank temp. sensor1	0 - 99 °C	-	-
0.4	Stor. tank temp. sensor2	0 - 99 °C	-	-
1.2	Code plug 8714411 XXX	0 - 255	-	-
1.5	Required flow temp.	0 - 99 °C	-	-
1.9	Module detection	no module detected bus module	-	-
2.0	Operating mode	-	normal Min Max	normal
2.2	Pump switch mode	-	1 - 3	2
2.3	Stor. tank charge output	-	0 - 100%	100 %
2.4	Anti-cycle mode	-	0 - 15 min	3 min
2.5	Max. flow temperature	-	35 - 88 °C	88 °C
2.6	Switch.diff.flow temperature	-	0 - 30 °C	0 °C
2.7	Autom. anti-cycle mode	-	on off	on
2.9	Actual output	0 - 100 %	-	-
3.0	Fan speed	0 - 255 U/s	-	-
3.3	Ionisations current	no low middle high	-	-
3.4	Pump mode	-	0 - 3	0 ¹⁾
3.5	Pump blocking time	-	0 - 240 s in 15-s increments	0 s
3.6	Software version	BF 11.XX	-	-

Table 1

	Text display message	Display	Range adjustable from - to	Reset Value
3.9	Link 8 - 9	open closed	-	-
	Link Ls-Lr	open closed	-	-
4.0	Stor. tank. therm.. (7-9)	blocked heat demand	-	-
4.1	Room therm. LSM	blocked heat demand	-	-
	LSM release	blocked heat demand	-	-
4.2	Timer ch. 1 (heating)	blocked heat demand	-	-
	Timer ch. 2 (hot wat.)	blocked heat demand	-	-
4.4	Heat demand (heating).	yes no	-	-
	Heat demand (stor. tank).	yes no	-	-
4.5	Heat demand (hot water).	yes no	-	-
	Keep hot period	yes no	-	-
4.6	Internal regulator	blocked heat demand	-	-
5.0	Max. output (heating)	-	27 - 100%	100 %
5.1	Permanent ignition	-	no yes	no
5.2	GFA status / error	00h - FFh	-	-
5.5	Min. output	-	27 - 100 %	27 %
5.8	Cyclic boiler starts	-	on off	on
5.9	Fan speed (start)	-	low high	low
6.7	Pump off (hot water).	-	off on	off

Table 1

	Text display message	Display	Range adjustable from - to	Reset Value
6.8	Cycle time (hot water)	-	0 - 60 min	0 min
6.9	Duration (hot water)	-	0 - 30 min	1 min
7.0	Pump map (heating)	-	0 Pump step adjustable 1 Const. pressure high 2 Const. pressure middle 3 Const. pressure low 4 Prop.pressure high 5 Prop.pressure low	4 Prop. pressure high
7.1	Map pump step (heat.).	-	2 - 7	7
7.2	Antiblock. map pump.	-	off on	on
7.3	Air purge mode	-	off on autom. deaktiv. permanent on	on autom. deaktiv at./ off
7.4	Actual map pump step	1 - 8	-	-
7.5	Map pump load index	0 ... 255	-	-
7.6	Map pump type	0 .. 99	-	-
7.7	Output reduction	-	off only in heating mode only in hot water mode in heat./hot water mode.	only in heating mode
8.5	Siphonfillprogram	-	on, boiler min.output, on, adjust. min output, off	on, boiler min. output
9.2	Hot water on demand	-	off on	on
9.3	GFA-Asic-error	00h - FFh	-	-

Table 1





1) The reset value depends on the code plug.

3.2 Explanation of service functions

0.0 Last fault

The last fault can also be recalled for servicing purposes when the appliance is functioning correctly.

To delete the stored fault:

- ▶ Delete fault (no fault displayed).
- ▶ Press the  button.
- ▶ Use the  or  button to select **yes**.
- ▶ Press the  button.

If a list of the last 10 indicated faults is required for servicing purposes, look under **Settings -> Service -> Further options -> Fault history**.

0.1 Flow NTC

The temperature measured by the NTC sensor on the CH flow pipe is indicated.

0.2 Hot water NTC

The temperature measured by the NTC sensor on the plate-type heat exchanger outflow is indicated.

0.3 Storage tank NTC 1

Indirectly heated heat store (SO..., SK..., ST...):
The temperature measured by NTC sensor 1 in the heat store is indicated.

Stratified-charge tank (ST...S):

The temperature measured by NTC sensor 2 at the **bottom** of the heat store is indicated.

0.4 Storage tank NTC 2

Stratified-charge tank (ST...S):

The temperature measured by NTC sensor 2 at the **top** of the heat store is indicated.

1.2 Code plug

The 10-digit part number of the code plug is indicated.

The code plug determines the appliance functions. If the appliance is converted from natural gas to LPG or vice versa (using conversion kit) the code plug also has to be changed.

1.5 Desired flow temp.

The CH flow temperature demanded by the text display module or a programmer connected to the bus module is displayed.

1.9 Module detection

The text display module shows the modules detected by the appliance.

2.0 Operating mode

There are 3 operating modes to choose from.

- **Normal mode:** the appliance operates according to the commands received from the programmer.

- **Min mode:** the appliance runs constantly at minimum output.

The text display shows **Min mode**. The 2-digit display alternates between the CH flow temperature and **_ _**.

- **Max mode:** the appliance runs constantly at maximum output.

The text display shows **Max mode**. The 2-digit display alternates between the CH flow temperature and **- -**.

2.3 Stor. tank charge outp

The heat store charging output can be set to any level between the minimum and maximum rated heat output for hot water according to the heat transfer capacity of the heat store.

- ▶ Enter the heat store charging output setting on the commissioning record enclosed with the appliance.

2.4 Anti-cycle mode

This function is only active if service function **2.7 Automatic anti-cycle mode** is **disabled**.

The anti-cycle time is factory set to 3 minutes.

The shortest possible period is 1 minute (recommended for single-pipe and hot-air heating systems).

The setting 0 means that the anti-cycle time is disabled.



If an outside-temperature controlled heating programmer is used, no setting is required.

The anti-cycle time is optimised by the programmer.

- ▶ Enter the anti-cycle time on the commissioning record enclosed with the appliance.

2.5 Max. flow temperature

The maximum CH flow temperature can be set to between 35 °C and 88 °C (factory setting).

2.6 Switch diff. flow NTC



If an outside-temperature controlled heating programmer is used, no setting is required on the appliance.

The switching difference is the permissible deviation from the specified CH flow temperature. It can be set in increments of 1 K. The adjustment range is from 0 to 30 K (factory setting: 0 K). The minimum CH flow temperature is 30 °C.

- ▶ Disable anti-cycle time (setting 0).
- ▶ The switching difference setting should be entered on the commissioning record supplied with the appliance.

2.7 Autom. anti-cycle mode

If an outside-temperature controlled programmer is connected to the appliance, the anti-cycle time is adjusted automatically.

Automatic adjustment of the anti-cycle time can be disabled. This may be necessary in the case of unfavourably dimensioned heating systems.

If automatic adjustment of the anti-cycle time is disabled, the length of the anti-cycle time must be set under service function 2.4.

- ▶ If automatic adjustment of the anti-cycle time has been disabled, this should be entered on the commissioning record enclosed with the appliance.

2.9 Actual output

The actual output of the appliance at the time viewed is displayed.

3.0 Fan speed

The current fan speed is displayed.

3.3 Ionisation current

The burner flame is monitored by measuring the ionisation current generated during combustion. If no ionisation current is detected, the gas valve shuts off. This ensures that unburned gas does not escape.

3.4 Pump mode (ZBR.. models only)

The possible settings are:

- **Pump mode 1:** if a heating pump and a 3-way valve for charging the heat store are connected. The 3-way valve is de-energised when the heat store circuit is open.
 - **Pump mode 2 (factory setting):** if a circulation pump and a heat store charging pump are connected. In ECO mode, if the circulation pump and the heat store charging pump call for heat simultaneously, the system alternates between 12 minutes heating and 12 minutes hot water.
 - **Pump mode 3:** if a circulation pump and a heat store charging pump are connected. In ECO mode, if the circulation pump and the heat store charging pump call for heat at the same time, both pumps run simultaneously. The heat store charging temperature has priority (up to 85 °C). The hydraulic configuration must be matched to this pump mode (use of a mixer unit and hydraulic balancing).
- ▶ The pump mode setting should be entered on the commissioning record enclosed with the appliance.

3.5 Pump blocking time (ZBR.. models only)



Only applies if service function 3.4, Pump mode, is set to Pump mode 1 (external 3-way valve for heat store charging is connected). Otherwise has no function.

If the system incorporates a 3-way valve external to the appliance, the heating pump is disabled while the 3-way valve is being actuated. therefore, the blocking time of the heating pump should be \geq the actuation time of the 3-way valve.

The blocking time has an adjustment range of 0 to 16, with each increment equivalent to 15 seconds. The adjustment range therefore equates to 0 to 240 seconds.

Factory setting is 30 seconds.

- ▶ Enter the pump blocking time on the commissioning record enclosed with the appliance.

3.6 Software version

The version number of the software is displayed.

3.9 Jumper 8 - 9 /

3.9 Jumper Ls - Lr

When supplied, the appliance has a jumper fitted across terminals 8-9 (= Heat demand). If that connection is opened (e.g. by a limiter for an underfloor heating system), heating mode is disabled.

When supplied, the appliance has a jumper fitted across terminals Ls-Lr (= Heat demand). If that connection is opened (e.g. by an external 2-point programmer), heating mode is disabled.

4.0 Stor. tank therm. (7 - 9)

When supplied, the appliance has no jumper across terminals 7- 9 (= Disabled). If that connection is closed (e.g. by a heat store thermostat) heat store charging is enabled.

4.1 Room therm. LSM/ 4.1 LSM release

When supplied, a jumper is fitted across terminals LZ - L1 on the LSM (= Heat demand). If that connection is opened (e.g. by a connected room thermostat), heating mode is disabled.

LSM release shows the total number of all possible enable signals connected via the LSM. As soon as a module connected to it (e.g. mechanical limiter for underfloor heating, limit switch on flue flap, combustion air flap, etc.) shuts off, heating and hot water modes are disabled.

4.2 Timer ch. 1 (heating)/ 4.2 Timer ch. 2 (hot water)

Shows the status of channel 1 of the timer integrated in the text display module or the separate programmer. If that channel's status is "Heat demand", heating mode will be activated according to the programmer commands.

Shows the status of channel 2 of the timer integrated in the text display module or the separate programmer. If that channel's status is "Heat demand", hot water mode will be activated according to the programmer commands.

4.4 Heat demand (heating)/ Heat demand (stor. tank) (ZSBR.. only)

Heat demand (heating) shows the heat demand status for the central heating system.

If this channel's status is "Heat demand", heating mode will be activated according to the programmer commands.

Heat demand (stor. tank) shows the heat demand status for charging the heat store.

If this channel's status is "Heat demand", the heat store will be charged according to the commands from the heat store thermostat or NTC sensor.

4.5 Heat demand (hot water)/ Keep hot period (ZWBR... models only)

Heat demand (hot water) shows the heat demand status for the hot water function.

If this channel's status is "Heat demand", the hot water function operates according to the commands from the hot water NTC sensor.

Keep hot period shows the constant hot water circuit status of the heat exchanger (ECO or Comfort mode). If this channel's status is "Heat demand", Comfort mode is active. If the status is "Disabled", ECO mode with demand detection is active.

4.6 Internal regulator

The boiler has an internal anti-cycle function which prevents the burner overheating if the heat output can not be dissipated even in Min mode. The appliance will then switch off even when the system is calling for heat.

It will subsequently switch on again

- after 5 seconds in hot water mode
- after 30 seconds in heat store charging mode
- after 0 to 15 minutes in heating mode (depending on the setting for service function 2.4 Anti-cycle mode).

The anti-cycle function is cancelled by

- switching the appliance off and on again at the master switch,
- another demand for heat,
- activating Min or Max mode
- or briefly switching to summer mode on the temperature control for CH flow.

5.0 Max. output (heating)

Some gas suppliers demand an output-dependent basic charge.

The heating output can be limited to any level between the min. rated heat output and the max. rated heat output to suit the specific heat requirements.



Even if the heating output is limited, the full rated heat output remains available for hot water or heat store charging.

The factory setting is maximum rated output – display shows "100 %".

5.1 Permanent ignition

This function allows permanent ignition without gas supply to be activated for the purposes of checking the ignition mechanism.

5.2 GFA status/error

The status of the automatic ignition module integrated in the PCB control board is indicated.

5.5 Min. output

The min. heat input is factory set, see technical data. The modulation range can be extended at the top end to suit the chimney conditions.

- ▶ Refer to settings table for heating and heat store charging output for details of the min. heat output in kW and the corresponding percentage (see installation instructions for boiler).
- ▶ Enter percentage on text display module and confirm.
- ▶ Measure gas flow rate and compare with the figures quoted for the percentage shown. If different, correct the percentage figure!
- ▶ Enter min. rated heat output on the commissioning record enclosed with the appliance.

5.8 Cyclic boiler starts (ZSBR 3/5-16 A... only)

When supplied, this function is activated on the above appliances and prevents start-up problems caused by poor ignition characteristics.

A truncated start cycle is activated if the burner has not been in operation for more than 3 hours.

During a truncated start cycle, the fan runs and the gas valve is opened long enough to completely fill the gas pipe with gas (approx. 1 - 2 seconds) but the burner is not ignited.

This function is not required, and can not be activated, on any other models.

6.7 Pump off (hot water)

The appliance is supplied with this function activated, i.e. there is a delay before the pump switches on in hot water mode. This means that cold water comes out of the pipe to begin with, followed by hot water once the pump switches on.

If the pump is set to switch on immediately (Pump off function deactivated), the hot water temperature rises gradually until the set temperature is reached.

If a stratified-charge tank is connected, it is useful to have the function activated.

The delayed cut-in of the pump then prevents cold water being pumped through the tank and cooling it down.

6.8 Cycle time (hot water) (ZWBR... only)

The appliance is supplied with the hot water cycle time set to 3 minutes.

The hot water cycle time specifies how long after hot water is drawn the pump continues to pump water through the internal hot water system.

6.9 Duration (hot water) (ZWBR... only)

The appliance is supplied with the hot water duration set to 3 minutes.

The hot water duration specifies how long after hot water is drawn heating mode remains disabled.

7.0 Pump map (heating) (not ZBR...)

The appliance is supplied with this function set to "4 Prop. pressure high" (see pump characteristic in boiler installation instructions).

The pump map indicates how the pump is controlled in heating mode. The pump switches between the various pump speeds so as to reproduce the characteristic curve selected. (The current setting can be viewed by means of service function 7.4.)

Changing the pump characteristic can be helpful if a lower pressure difference will guarantee the necessary circulation on the basis of the system dimensions and pump characteristic (see installation instructions).



In order to save as much energy as possible and to minimise the possibility of water circulation noise, a low characteristic should be chosen.

If this parameter is set to "0 Pump step adjustable", then the pump speed set under function 7.1 is active.

7.1 Map pump step (heat.) (not ZBR...)

The appliance is supplied with this function set to 1 (see pump characteristic in boiler installation instructions). However, the setting is only active if function 7.0, Pump map (heating), is set to "0 Pump step adjustable".

This service function corresponds to the pump speed switch used on conventional heating pumps.

7.2 Antiblock. map pump (not ZBR...)

The appliance is supplied with this function activated. If the pump threatens to jam, an oscillating pump action is activated. Afterwards, the required operating mode is continued.

7.3 Aeration mode (not ZBR...)

The first time the appliance is switched on, a once-only venting function is activated. The heating pump then switches on and off at intervals. This sequence lasts about 8 minutes and the text display shows "Aeration mode". The 2-digit display shows "o^o" in alternation with the CH flow temperature. The automatic vent must be opened and then closed again once the venting sequence is complete.



The venting function can be activated manually after servicing.

- If the venting function is set to "On, autom. deactivate.", once the sequence has been completed.

7.4 Actual map pump step (not ZBR...)

The currently active pump speed is displayed (see function 7.0).

7.5 Map pump load index (not ZBR...)

The load index is displayed.

7.6 Map pump type (not ZBR...)

The pump type code of the pump fitted is displayed.

7.7 Output reduction

The appliance is supplied with this function activated. It prevents overload of the heat exchanger with high CH flow temperatures.

The output of the burner is reduced according to the CH flow temperature, i.e. up to 80 °C flow temperature, full burner output is permitted. Above 80 °C, the burner output is reduced as flow temperature increases up to 90 °C at which only minimum output is available (even with maximum heat demand).

This function can be deactivated for hot water and/or central heating mode.

8.5 Siphon fill program

The trap filling programme ensures that the condensation trap is filled when the appliance is first installed or after it has been shut down for a long period: The condensation trap prevents flue gas escaping from the appliance into the room in which it is installed.

The trap filling programme is activated:

- the appliance is switched on at the master switch
- the burner has not been in operation for at least 48 hours
- the appliance is switched from summer to winter mode.

The next time the heating or hot water system calls for heat, the appliance is held at minimum output for 15 minutes. The trap filling programme remains active until the appliance has completed 15 minutes of operation at minimum output.

The text display shows "Siphon fill program" and the 2-digit display alternates between „II-“ and the CH flow temperature.

The factory setting is „1“ (activated).



Warning: if the condensation trap is not filled, flue gas can escape!

- ▶ Only deactivate the trap filling programme in order to carry out servicing work.
- ▶ Always re-activate trap filling programme once servicing is complete.

9.2 Hot water on demand

The appliance is supplied with this function activated.

This function relates to mode, the  button lights up.

The demand detection function enables maximum gas and water economy.

Briefly turning a hot water tap on and then off again signals demand to the appliance which then heats up the water to the set temperature.

Hot water is then available at short notice.

9.3 GFA-Asic error (automatic ignition module, extended messages)

The status of, or an error message from the automatic ignition module integrated in the PCB control board is displayed.

4 Rectifying faults

4.1 Boiler failure codes indication

4.1.1 ... on the boiler

In order to identify the specific boiler failure a two digit alphanumeric code is used. This allows a quick fault identification and solution.

The text display shows the message **Fault EA. Please call service**, for example. At the same time, the fault code appears on the 2-digit display, in this example: **EA**. You can view an explanatory description of the fault indicated by going to **Settings -> Service -> Service parameters**, in this example: **EA: During operation: Flame not detected**.

The failures can be divided into four basic typologies, as described:

- The appliance continues to work at a minimum function level (e. g. with error codes A5, A7, A8, AC, Ad, CC, FC).
- The appliance is locked until the failure is repaired (e. g. with error codes (b1, C1, d1, d3, E2, F0)).
- The appliance is locked, until the ON/OFF switch is turned (A1).
- The boiler has shut down and locked out (⚠ flashes) and remains so until the cause of the fault has been eliminated and the lock-out cancelled (e.g. E9, EA, F0, F7, FA,Fd).



To unblock the appliance:

- ▶ Press the unblock button (⚠) until the digit -- appears on the display. Once the appliance starts up successfully, the fault disappears from the text display.

4.1.2 ... on the programmer (optional accessory)

A TW 2 remote control unit can also be connected to the text display module.

If other/more functions are required, another programmer must be connected. Those programmers are then controlled via the bus module BM1.

For more detailed information, refer to the installation instructions for the boiler and the installed programmer.

Faults on this programmer are indicated by text messages on the programmer display.

Once the fault has been put right, the programmer reverts to its normal display.

4.2 Summary

4.2.1 Appliance faults

Appliance faults	ZBR ... A	ZSBR ... A	ZWBR ... A	Page
A1		X	X	17
A5		X		18
A7	X	X	X	19
A8	X	X	X	20
Ad	X	X	X	21
b1	X	X	X	22
C1	X	X	X	23
d3	X	X	X	24
E2	X	X	X	25
E9	X	X	X	26
EA	X	X	X	28
F0	X	X	X	32
F7	X	X	X	33
FA	X	X	X	34
FC	X	X	X	35
Fd	X	X	X	35

Table 2

4.2.2 Faults that are not indicated on any display

Appliance faults	ZBR ... A	ZSBR ... A	ZWBR ... A	Page
Excessive burner noise, rumbling noises	X	X	X	36
Flue gas levels incorrect, CO level too high	X	X	X	37
Ignition too harsh, ignition poor	X	X	X	38
Boiler indicates P1, P2, P3 at start-up and then restarts with P1, ...	X	X	X	36

Table 3

Appliance faults	ZBR ... A	ZSBR ... A	ZWBR ... A	Page
Loose or broken contact on heat store NTC sensor	X	X		39
Specified CH flow temperature from TA... programmer exceeded	X	X		40

Table 3

Programmer faults	TR 2	Page
Set room temperature not reached	X	41
Set room temperature exceeded by large amount	X	43
Set room temperature not reached		41
Temperature rises instead of falling	X	43
Room temperature too high in Economy mode	X	43
Incorrect or no modulation	X	43
Heat store fails to heat up		44

Table 4

4.3 How to use the fault tables

The procedure is explained using the fault code EA as an example:

The table heading shows the fault code and a general description of the fault.



In the example shown, you are instructed to note the current settings before going any further. If you can see the flame (answer to question is “yes”) you move on to Step 5. (↓ 5.). The question asked in Step 5 is “Is there a problem with the flue”. The flue must then be checked.

If the answer to the first question (“Is burner flame visible?”) was “no”, then you go to and answer Question 2, “Is the gas cock turned on?”. If the gas cock is turned off, it must be turned on and the appliance reset. To do so, you press the  button. **Restart the appliance** and run through a complete heat-demand cycle until the appliance switches off.

If the fault is now cured, the appliance will revert to normal operation and the fault-finding process is complete. Now simply re-check the setting of the two temperature controls.

If the fault EA recurs **during** the heat-demand cycle, it will be shown on the display again. In that case continue the fault finding procedure from Step 3 (thermal cut-out in gas cock) as described above.

If a different fault code is displayed after the heat-demand cycle, find the appropriate section of the fault finding table and work through the procedure described step by step.

EA and  flashing.			
Flame not detected			
	Check		Action
1.	Is burner flame visible?	yes:	↓5.
		no:	↓2.
2.	Is the gas cock turned on?	yes:	↓3.
		no:	▶ Turn on the gas cock. ▶ Press  , does appliance restart??? EA? ↓3.
3.	Did the thermal security of the gas cock lock out?	yes:	▶ ...
		no:	↓ ...
4.	...		
5.	Is there a problem with the flue? ▶ Check CO ₂ level in combustion air. > 0,2 % CO ₂ ?	yes:	▶ Check the flue.
		no:	↓
...	...		

4.4 Faults indicated on display

<h1>A1</h1> flashing.			
Controlled-characteristic pump has run dry			
	Check		Action
1.	System pressure below 1.2 bar?	yes:	<ul style="list-style-type: none"> ▶ Power OFF the appliance. ▶ Check appliance and system for water leaks and repair as necessary. ▶ Top up system. ▶ Turn ON the appliance. A1? ↓2.
		no:	↓2.
2.	Activate venting sequence.		<ul style="list-style-type: none"> ▶ Activate menu option Show service parameters. ▶ Select 7.3 Aeration mode select setting On, autom. deactivat. and confirm. ▶ Vent appliance¹⁾. ▶ Vent radiators. ↓3.
3.	Audible bearing damage on pump?	yes:	<ul style="list-style-type: none"> ▶ Power OFF the appliance. ▶ Drain appliance. ▶ Replace pump. ▶ Top up system. ▶ Turn ON the appliance.

1) See installation instructions

A5 flashing.			
Heat store NTC sensor 2 defective			
	Check		Action
1.	<ul style="list-style-type: none"> ▶ Activate menu option Show service parameters. ▶ Select .4 Stor.tank temp.sensor2 . Is a temperature between 0. and 5. displayed? 	yes:	<ul style="list-style-type: none"> ▶ Is the connector for heat store NTC sensor 2 corroded¹⁾, damaged or dirty? Replace affected components. ↓2.
		no:	↓3.
2.	<ul style="list-style-type: none"> ▶ Disconnect connector for heat store NTC sensor 2. ▶ Short-circuit the 2-pin connector on the end of the 20-pin connector lead assembly. After max. 60 sec: Display changes to temperature between 100. and 95.? 	yes:	<ul style="list-style-type: none"> ▶ Power OFF the appliance. ▶ Change heat store NTC sensor 2. ▶ Plug the connection wire. ▶ Turn ON the appliance. A7? ↓3.
		no:	<ul style="list-style-type: none"> ▶ Change the 20-pin connector lead assembly. ↓3.
3.	Temperature between 95. and 100. is displayed. <ul style="list-style-type: none"> ▶ Unplug the connector. After max. 60 sec.: Does the displayed code change to a value between 0. and 5.? 	yes:	<ul style="list-style-type: none"> ▶ Power OFF the appliance. ▶ Change heat store NTC sensor 2. ▶ Plug the connection wire. ▶ Turn ON the appliance. A7? ↓4.
		no:	↓4.
4.	<ul style="list-style-type: none"> ▶ Unplug the 20-pin connector lead assembly from the Heatronix. After max. 60 sec.: Does the displayed code change to a value between 0. and 5.? 	yes:	<ul style="list-style-type: none"> ▶ Change the 20-pin connector lead assembly.
		no:	<ul style="list-style-type: none"> ▶ Power OFF the appliance. ▶ Disconnect the boiler electrical connection. ▶ Change PCB control board. ▶ Reconnect the boiler electrical connection. ▶ Turn ON the appliance.

1) For notes, refer to Appendix.

A7 flashing.

Hot water NTC sensor defective

	Check		Action
1.	<ul style="list-style-type: none"> ▶ Activate menu option Show service parameters. ▶ Select .2 Hot water temp.sensor . Is a temperature between 0. and 5. displayed? 	yes:	<ul style="list-style-type: none"> ▶ Is the connector for hot water NTC sensor corroded¹⁾, damaged or dirty? Replace affected components. ↓2.
		no:	↓3.
2.	<ul style="list-style-type: none"> ▶ Disconnect connector for hot water NTC sensor. ▶ Short-circuit the 2-pin connector on the end of the 20-pin connector lead assembly. Display changes to temperature between 100. and 95.? 	yes:	<ul style="list-style-type: none"> ▶ Power OFF the appliance. ▶ Change hot water NTC sensor. ▶ Plug the connection wire. ▶ Turn ON the appliance. A7? ↓3.
		no:	<ul style="list-style-type: none"> ▶ Change the 20-pin connector lead assembly. ↓3.
3.	Temperature between 95. and 100. is displayed. <ul style="list-style-type: none"> ▶ Unplug the connector. After max. 60 sec.: Does the displayed code change to a value between 0. and 5.? 	yes:	<ul style="list-style-type: none"> ▶ Power OFF the appliance. ▶ Change hot water NTC sensor. ▶ Plug the connection wire. ▶ Turn ON the appliance. A7? ↓4.
		no:	↓4.
4.	<ul style="list-style-type: none"> ▶ Unplug the 20-pin connector lead assembly from the Heatronic. After max. 60 sec.: Does the displayed code change to a value between 0. and 5.? 	yes:	<ul style="list-style-type: none"> ▶ Change the 20-pin connector lead assembly.
		no:	<ul style="list-style-type: none"> ▶ Power OFF the appliance. ▶ Disconnect the boiler electrical connection. ▶ Change PCB control board. ▶ Reconnect the boiler electrical connection. ▶ Turn ON the appliance.

1) For notes, refer to Appendix.

<h1>A8</h1> flashing.			
No correct electrical connection			
	Check		Action
1.	Mode selector switch is between two settings		<ul style="list-style-type: none"> ▶ Turn switch until it clicks into position. A8? ↓2.
2.	<ul style="list-style-type: none"> ▶ Power OFF the appliance. Wiring between TR 2 and textdisplay OK? <ul style="list-style-type: none"> • Terminal 3 on TR 2 connected to Terminal 3 on textdisplay ? • Terminal 4 ... Terminal 4 etc.	yes:	<ul style="list-style-type: none"> ▶ Turn ON the appliance. ↓3.
		no:	<ul style="list-style-type: none"> ▶ Rewire correctly as specified in the installation instructions. ▶ Turn ON the appliance. after 90 sek.: A8? ↓3.
3.	Lead(s) defective.		<ul style="list-style-type: none"> ▶ Check leads for continuity and replace as necessary. A8? ↓4.
4.	TR 2 defective.		<ul style="list-style-type: none"> ▶ Power OFF the appliance. ▶ Change TR 2 . ▶ Turn ON the appliance.

Ad flashing.

Heat store NTC sensor 1 not detected

	Check		Action
1.	Is lead for heat store NTC sensor correctly routed, i.e. not through cable clamp?	yes:	↓2.
		no:	▶ Route connecting lead for heat store temperature sensor as specified in installation instructions.
2.	<ul style="list-style-type: none"> ▶ Activate menu option Show service parameters. ▶ Select .3 Stor.tank temp.sensor1 . Is a temperature between 0. and 5. displayed?	yes:	Connector on end of NTC sensor lead: <ul style="list-style-type: none"> ▶ Flue gas connector corroded¹⁾, damaged or dirty? Change relative parts. ▶ Press button . Ad? ↓3.
		no:	↓4.
3.	Heat store -NTC 1: <ul style="list-style-type: none"> ▶ Unplug connector from PCB control board. ▶ Short circuit the connector using wire jumper. After max. 60 sec: Display changes to temperature between 100. and 95.	yes:	▶ Replace heat store NTC sensor 1.
		no:	<ul style="list-style-type: none"> ▶ Power OFF the appliance. ▶ Disconnect the boiler electrical connection. ▶ Change PCB control board. ▶ Reconnect the boiler electrical connection. ▶ Turn ON the appliance.
4.	Temperature between 95. and 100. is displayed. <ul style="list-style-type: none"> ▶ Unplug the connector. After max. 60 sec.: Does the displayed code change to a value between 0. and 5. ?	yes:	▶ Replace heat store NTC sensor 1.
		no:	<ul style="list-style-type: none"> ▶ Power OFF the appliance. ▶ Disconnect the boiler electrical connection. ▶ Change PCB control board. ▶ Reconnect the boiler electrical connection. ▶ Turn ON the appliance.

1)

b1 flashing.

Code plug not detected.

	Check		Action
1.	No fault or fault code FC displayed on text display?	yes:	<ul style="list-style-type: none"> ▶ Power OFF the appliance. ▶ Fit code plug (correctly), making sure code number (see Appendix) is correct. ▶ Turn ON the appliance. b1? ↓2.
		no:	↓2.
2.	<ul style="list-style-type: none"> ▶ Activate menu option Show service parameters. ▶ Select 1.2 Code plug. ▶ Compare number displayed with that shown in Appendix. No number or incorrect number (last three digits) displayed. 	yes:	↓2.
		no:	↓4.
3.	Code plug loose, incorrect or defective.		<ul style="list-style-type: none"> ▶ Power OFF the appliance. ▶ Replace code plug¹⁾, making sure code number is correct. ▶ Turn ON the appliance. b1? ↓4.
4.	The PCB control board is damaged.		<ul style="list-style-type: none"> ▶ Power OFF the appliance. ▶ Disconnect the boiler electrical connection. ▶ Change PCB control board. ▶ Reconnect the boiler electrical connection. ▶ Turn ON the appliance.

1) For order no., refer to Appendix

C1 flashing.**Fan speed too low**

	Check		Action
1.	Fan lead connector properly connected?	yes:	↓2.
		no:	<ul style="list-style-type: none"> ▶ Power OFF the appliance. ▶ Plug in connector. ▶ Turn ON the appliance. C6? ↓2.
2.	Fan lead defective?	yes:	<ul style="list-style-type: none"> ▶ Power OFF the appliance. ▶ Replace fan lead. ▶ Turn ON the appliance. C6? ↓3.
		no:	↓3.
3.	Fan defective?	yes:	<ul style="list-style-type: none"> ▶ Power OFF the appliance. ▶ Plug the connection wire. ▶ Replace fan. ▶ Plug the connection wire. ▶ Turn ON the appliance. C6? ↓4.
		no:	↓4.
4.	The PCB control board is damaged.		<ul style="list-style-type: none"> ▶ Power OFF the appliance. ▶ Disconnect the boiler electrical connection. ▶ Change PCB control board. ▶ Reconnect the boiler electrical connection. ▶ Turn ON the appliance.

d3 flashing.**Wrong signal from pin 8-9.**

	Check		Action
1.	Jumper 8 - 9 fitted correctly?	yes:	↓2.
		no:	<ul style="list-style-type: none"> ▶ Power OFF the appliance. ▶ Fit jumper 8 - 9 correctly, tighten screw. ▶ Turn ON the appliance. d3? ↓2.
2.	<ul style="list-style-type: none"> ▶ Turn ON the appliance. ▶ Measure voltage between Terminal 4 and Terminal 8. 24 V DC?	yes:	↓3.
		no:	↓5.
3.	Heat store NTC sensor connected to terminals 7, 8 and 9?	yes:	<ul style="list-style-type: none"> ▶ Power OFF the appliance. ▶ Plug heat store NTC sensor connector into PCB control board (303, page 46, Pos. 303). If lead has no connector: replace heat store NTC sensor. ▶ Turn ON the appliance. d3? ↓4.
		no:	↓4.
4.	Existing heat store thermostat connected to Terminals 7, 8 and 9?	yes:	<ul style="list-style-type: none"> ▶ Power OFF the appliance. ▶ Fix the additional bridge 8-9 in the right position and close the screws. ▶ Turn ON the appliance. d3? ↓5.
		no:	↓5.
5.	The PCB control board is damaged.		<ul style="list-style-type: none"> ▶ Power OFF the appliance. ▶ Disconnect the boiler electrical connection. ▶ Change PCB control board. ▶ Reconnect the boiler electrical connection. ▶ Turn ON the appliance.





E2 flashing.

The heating outlet NTC sensor is damaged.

	Check		Action
1.	<ul style="list-style-type: none"> ▶ Activate menu option Show service parameters. ▶ Select .1 Flow temp.sensor. Is a temperature between 0. and 5. displayed? 	yes:	The heating outlet NTC sensor is in short circuit: <ul style="list-style-type: none"> ▶ Power OFF the appliance. ▶ Replace CH flow NTC sensor; observe fitting instructions for NTC sensor when doing so. ▶ Turn ON the appliance. E2? ↓2.
		no:	↓2.
2.	Heating outlet NTC sensor: Temperature between 95. and 100. is displayed.	yes:	The CH flow NTC sensor is interrupted: <ul style="list-style-type: none"> ▶ Power OFF the appliance. ▶ Replace CH flow NTC sensor; observe fitting instructions for NTC sensor when doing so. ▶ Turn ON the appliance. E2? ↓3.
		no:	↓3.
3.	Check if the 20-pin connector lead assembly is damaged.		<ul style="list-style-type: none"> ▶ Power OFF the appliance. ▶ Change the 20-pin connector lead assembly. ▶ Turn ON the appliance. E2? ↓4.
4.	The PCB control board is damaged.		<ul style="list-style-type: none"> ▶ Power OFF the appliance. ▶ Disconnect the boiler electrical connection. ▶ Change PCB control board. ▶ Reconnect the boiler electrical connection. ▶ Turn ON the appliance.

E9 and flashing.

Safety temperature limiter has tripped.

	Check		Action
1.	Is the heating pressure between 1 and 2 bar?	yes:	<ul style="list-style-type: none"> ▶ Top up system. ▶ Vent appliance. ▶ Press , does appliance restart??? E9? ↓2.
		no:	↓2.
2.	Is the pump blocked?	yes:	<ul style="list-style-type: none"> ▶ Unblock the pump. If pump won't start: <ul style="list-style-type: none"> ▶ Power OFF the appliance. ▶ Disconnect the boiler electrical connection. ▶ Change the pump. ▶ Reconnect the boiler electrical connection. ▶ Turn ON the appliance. ▶ Press , does appliance restart??? E9? ↓3.
		no:	↓3.
3.	Is lead disconnected from one/both safety temperature limiters?	yes:	<ul style="list-style-type: none"> ▶ Power OFF the appliance. ▶ Connect lead. ▶ Turn ON the appliance. ▶ Press , does appliance restart??? E9? ↓4.
		no:	↓4.
4.	<ul style="list-style-type: none"> ▶ Power OFF the appliance. ▶ Unplug the connector from the cut-off device. ▶ Measure the NTC electrical resistance. R = ∞?	yes:	<ul style="list-style-type: none"> ▶ Change the over heating cut-off device. ▶ Connect flue gas safety temperature limiter lead. ▶ Turn ON the appliance. ▶ Press , does appliance restart??? E9? ↓5.
		no:	<ul style="list-style-type: none"> ▶ Connect flue gas safety temperature limiter lead. ▶ Turn ON the appliance. E9? ↓5.





E9 and flashing.

Safety temperature limiter has tripped.

	Check		Action
5.	<ul style="list-style-type: none"> ▶ Power OFF the appliance. ▶ Remove fuse SI 3 from appliance PCB control board and test for continuity. <p>R = ∞?</p>	yes:	<ul style="list-style-type: none"> ▶ Change the fuse. ▶ Turn ON the appliance. ▶ Press , does appliance restart??? <p>E9? ↓6.</p>
		no:	<ul style="list-style-type: none"> ▶ Remount the fuse. ▶ Turn ON the appliance.
6.	The PCB control board is damaged.		<ul style="list-style-type: none"> ▶ Power OFF the appliance. ▶ Disconnect the boiler electrical connection. ▶ Change PCB control board. ▶ Reconnect the boiler electrical connection. ▶ Turn ON the appliance.



EA and flashing.

During operation: flame not detected

	Check		Action
1.	Is the flame present?	yes:	↓6.
		no:	↓2.
2.	Is the gas cock open?	yes:	↓3.
		no:	<ul style="list-style-type: none"> ▶ Open the gas cock ▶ Press , does appliance restart??? EA? ↓3.
3.	Is there air in the supply pipe?	yes:	<ul style="list-style-type: none"> ▶ Vent supply pipe. ▶ Press , does appliance restart??? EA? ↓4.
		no:	↓4.
4.	Did the thermal security of the gas cock lock out?	yes:	<ul style="list-style-type: none"> ▶ Reset security. ▶ Press , does appliance restart??? EA? ↓5.
		no:	↓5.
5.	Natural gas models: does the building have a supply pressure regulator?	yes:	<ul style="list-style-type: none"> ▶ Check that it is fitted correctly and functioning properly and correct if necessary. ▶ Check supply pressure, inform gas company if outside correct range. ▶ Press , does appliance restart??? EA? ↓6.
		no:	↓6.
	LPG models: is the flow rate of the gas supply to the appliance correct?	yes:	↓6.
		no:	<ul style="list-style-type: none"> ▶ Is there enough gas in the supply cylinder? ▶ Is there air in the supply pipe? ▶ Is the solenoid valve in the “meter cabinet” opening? ▶ Is the supply pressure OK? (if the supply pressure is too high, check the pressure regulator in the “meter cabinet” and on the LPG supply cylinder). ▶ Press , does appliance restart??? EA? ↓6.





EA and flashing.

During operation: flame not detected

	Check		Action
6.	Is the ground connection correct?	yes:	↓7.
		no:	<ul style="list-style-type: none"> ▶ Rewire correctly as specified in the installation instructions. ▶ Press , does appliance restart??? EA? ↓7.
7.	Two phase net: Is there a resistor fitted between Pe and N?	yes:	↓8.
		no:	<ul style="list-style-type: none"> ▶ Power OFF the appliance. ▶ Disconnect the boiler electrical connection. ▶ Insert resistance (Order no. 8 900 431 516) between the ground and the N connection. ▶ Reconnect the boiler electrical connection. ▶ Turn ON the appliance. ▶ Press , does appliance restart??? EA? ↓10.
8.	Is condensation trap in condensing boiler blocked?	yes:	<ul style="list-style-type: none"> ▶ Unscrew condensation trap and clean. ▶ Press , does appliance restart??? EA? ↓12.
		no:	↓9.
9.	Check the gas valve? <ul style="list-style-type: none"> ▶ Power OFF the appliance. ▶ Unplug the connectors from the gas valve. ▶ Measure the gas valve coils I and II electrical resistance. R = 164 ± 40 Ω? 	yes:	<ul style="list-style-type: none"> ▶ Reconnect the gas valve. ▶ Turn ON the appliance. ▶ Press , does appliance restart??? EA? ↓10.
		no:	<ul style="list-style-type: none"> ▶ Change the gas valve. ▶ Reconnect the gas valve. ▶ Turn ON the appliance. ▶ Press , does appliance restart??? EA? ↓10.
10.	Is flue blocked? <ul style="list-style-type: none"> ▶ Check CO₂ level in combustion air. > 0,2 % CO₂? 	yes:	<ul style="list-style-type: none"> ▶ Check the flue. ▶ Press , does appliance restart??? EA? ↓11.
		no:	↓11.



EA and flashing.

During operation: flame not detected





	Check		Action
11.	Is flue gas CO ₂ level incorrect ¹⁾ ?	yes:	<ul style="list-style-type: none"> ▶ Adjust to correct level. ▶ Press , does appliance restart??? EA? ↓12.
		no:	↓12.
12.	<ul style="list-style-type: none"> ▶ Activate menu option Show service parameters. ▶ Select 5.1 Permanent ignition. Continuous ignition OK?	yes:	↓13.
		no:	↓16.
13.	Ignition lead connected to ignition electrodes?	yes:	↓14.
		no:	<ul style="list-style-type: none"> ▶ Connect cable to ignition electrode. ▶ Press , does appliance restart??? EA? ↓14.
14.	Ignition cable connector engaged in switchbox?	yes:	↓15.
		no:	<ul style="list-style-type: none"> ▶ Power OFF the appliance. ▶ Engage ignition cable connector in switchbox. ▶ Turn ON the appliance. ▶ Press , does appliance restart??? EA? ↓15.
15.	Ignition cable defective?	yes:	<ul style="list-style-type: none"> ▶ Power OFF the appliance. ▶ Replace ignition cable. ▶ Turn ON the appliance. ▶ Press , does appliance restart??? EA? ↓16.
		no:	↓16.
16.	<ul style="list-style-type: none"> ▶ Select 3.3 Ionisation current. Measured ionisation current medium or high?	yes:	↓18.
		no:	↓17.

EA and flashing.

During operation: flame not detected



	Check		Action
17.	Electrode assembly defective? ▶ Power OFF the appliance. ▶ Remove electrode assembly. Electrodes worn out?	yes:	▶ Replace electrode assembly. ▶ Turn ON the appliance. ▶ Press  , does appliance restart??? EA? ↓18.
		no:	▶ Refit electrode assembly. ▶ Turn ON the appliance. ▶ Press  , does appliance restart??? EA? ↓18.
18.	Check if the 20-pin connector lead assembly is damaged.		▶ Power OFF the appliance. ▶ Change the 20-pin connector lead assembly. ▶ Turn ON the appliance. ▶ Press  , does appliance restart??? EA? ↓19.
19.	The PCB control board is damaged.		▶ Power OFF the appliance. ▶ Disconnect the boiler electrical connection. ▶ Change PCB control board. ▶ Reconnect the boiler electrical connection. ▶ Turn ON the appliance.

1) See installation instructions

<h1>F0</h1> (and possibly ) flashing.			
Internal failure			
	Check		Action
1.	<ul style="list-style-type: none"> ▶ Activate menu option Show service parameters. ▶ Select 9.3 GFA-Asic-error. A message is displayed. 		<ul style="list-style-type: none"> ▶ Record figure displayed in service report. ↓2.
2.	<ul style="list-style-type: none"> ▶ Select 5.2 GFA status / error. A message is displayed. 		<ul style="list-style-type: none"> ▶ Record figure displayed in service report.
3.	<ul style="list-style-type: none"> ▶ Select Settings -> Service -> Further options -> Fault history. Other faults apart from F0 displayed? 	yes:	<ul style="list-style-type: none"> ▶ Deal with fault(s) displayed as instructed in relevant fault table(s) .
		no:	↓3.
4.	 flashing?	yes:	<ul style="list-style-type: none"> ▶ Press button . ▶ Initiate demand for heat by pressing the  button and then cancel after 30 seconds by pressing the button again. ▶ Initiate demand for heat twice more as described above. F0? ↓4.
		no:	↓4.
5.	The PCB control board is damaged.		<ul style="list-style-type: none"> ▶ Power OFF the appliance. ▶ Disconnect the boiler electrical connection. ▶ Change PCB control board. ▶ Reconnect the boiler electrical connection. ▶ Turn ON the appliance.



F7 and flashing.

Although appliance switches off, flame still detected

	Check		Action
1.	Electrode(s) dirty or defective.		<ul style="list-style-type: none"> ▶ Power OFF the appliance. ▶ Replace electrode assembly. ▶ Turn ON the appliance. ▶ Press , does appliance restart??? F7? ↓2.
2.	<ul style="list-style-type: none"> ▶ Power OFF the appliance. ▶ Disconnect the boiler electrical connection. ▶ Remove PCB control board. PCB control board damp?	yes:	<ul style="list-style-type: none"> ▶ Dry PCB control board (e.g. with hair dryer). ▶ Refit PCB control board. ▶ Reconnect the boiler electrical connection. ▶ Press , does appliance restart??? F7? ↓3.
		no:	↓3.
3.	Is there a problem with the flue? <ul style="list-style-type: none"> ▶ Check CO₂ level in combustion air. > 0,2 % CO₂? 	yes:	▶ Check flue and repair or replace if necessary.
		no:	↓4.
4.	The PCB control board is damaged.		<ul style="list-style-type: none"> ▶ Power OFF the appliance. ▶ Disconnect the boiler electrical connection. ▶ Change PCB control board. ▶ Reconnect the boiler electrical connection. ▶ Turn ON the appliance.

FA and flashing.

After appliance switches off flame is detected

	Check		Action
1.	Is condensation trap in condensing boiler blocked?	yes:	<ul style="list-style-type: none"> ▶ Clean condensation trap discharge pipe. ▶ Press , does appliance restart??? FA? ↓2.
		no:	↓2.
2.	Electrodes faulty.		<ul style="list-style-type: none"> ▶ Replace electrode assembly. ▶ Turn ON the appliance. ▶ Press , does appliance restart??? FA? ▶ Power OFF the appliance. ↓3.
3.	Problem with flue? ▶ Check CO ₂ level in combustion air. > 0,2 % CO ₂ ?	yes:	<ul style="list-style-type: none"> ▶ Check flue and repair or replace if necessary. ▶ Press , does appliance restart??? FA? ▶ Power OFF the appliance. ↓4.
		no:	↓4.
4.	The gas valve is damaged.		<ul style="list-style-type: none"> ▶ Change the gas valve. ▶ Turn ON the appliance. ▶ Press , does appliance restart??? FA? ▶ Power OFF the appliance. ↓5.
5.	Check if the 20-pin connector lead assembly is damaged.		<ul style="list-style-type: none"> ▶ Change the 20-pin connector lead assembly. ▶ Turn ON the appliance. ▶ Press , does appliance restart??? FA? ▶ Power OFF the appliance. ↓6.
6.	The PCB control board is damaged.		<ul style="list-style-type: none"> ▶ Disconnect the boiler electrical connection. ▶ Change PCB control board. ▶ Reconnect the boiler electrical connection. ▶ Turn ON the appliance.

FC flashing.**Text display module not detected**

	Check		Action
1.	No fault or fault code FC displayed on text display?		<ul style="list-style-type: none"> ▶ Power OFF the appliance. ▶ Fit code plug (correctly), making sure code number is correct (see Appendix). ▶ Turn ON the appliance. FC? ↓2.
2.	<ul style="list-style-type: none"> ▶ Unplug text display module connector. ▶ Connecting lead between text display module and Heatronic OK.? 	yes:	<ul style="list-style-type: none"> ▶ Plug in connector. FC? ↓3.
		no:	<ul style="list-style-type: none"> ▶ Replace text display module. FC? ↓3.
3.	Text display module defective.		<ul style="list-style-type: none"> ▶ Replace text display module.

Fd and  flashing.**Reset button pressed inadvertently**

	Check		Action
1.			<ul style="list-style-type: none"> ▶ Press button  again.
2.	The PCB control board is damaged.		<ul style="list-style-type: none"> ▶ Disconnect the boiler electrical connection. ▶ Change PCB control board. ▶ Reconnect the boiler electrical connection. ▶ Turn ON the appliance.

4.5 Faults that are not displayed

4.5.1 Appliance faults





Boiler indicates P1, P2, P3 at start-up and then restarts with P1..			
	Check		Action
1.	Fuse T 1.6 A (312) defective.	yes:	<ul style="list-style-type: none"> ▶ Turn ON the appliance. ▶ Change the fuse. ▶ Power OFF the appliance. Start sequence not completed? ↓2.
		no:	↓2.
2.	The PCB control board is damaged.		▶ Change PCB control board.

Excessive burner noise, rumbling noises			
	Check		Action
1.	Does the gas supply type match the specifications on the appliance identification plate?	yes:	↓2.
		no:	▶ Convert appliance to correct gas type ¹⁾ .
2.	▶ Test gas supply pressure - OK? ¹⁾ ?	yes:	↓3.
		no:	<ul style="list-style-type: none"> ▶ Decommission appliance. ▶ Notify gas company.
3.	Problem with flue? ▶ Check CO ₂ level in combustion air. > 0,2 % CO ₂ ?	yes:	▶ Check flue and repair or replace if necessary.
		no:	↓4.
4.	▶ Remove silencer, flue pipe and mixer unit. Is internal flue pipe/silencer dirty or clogged or are seals defective or incorrectly fitted?	yes:	<ul style="list-style-type: none"> ▶ Repair or replace components. ▶ Grease seal before fitting, ▶ Make sure it is fitted in correct position.
		no:	↓5.
5.	Flue gas CO ₂ levels measured at min. and max. load do not match specified levels ¹⁾ . ▶ Measure CO ₂ levels.	yes:	▶ Adjust CO ₂ levels.
		no:	<ul style="list-style-type: none"> ▶ Power OFF the appliance. ▶ Change the gas valve. ▶ Turn ON the appliance.

1) See installation instructions

Flue gas levels incorrect, CO level too high			
	Check		Action
1.	Does the gas supply type match the specifications on the appliance identification plate?	yes:	↓2.
		no:	▶ Convert appliance to correct gas type ¹⁾ .
2.	▶ Test gas supply pressure ¹⁾ , - OK?	yes:	↓3.
		no:	▶ Decommission appliance. ▶ Notify gas company.
3.	Problem with flue? ▶ Check CO ₂ level in combustion air. > 0,2 % CO ₂ ?	yes:	▶ Check flue and repair or replace if necessary.
		no:	↓4.
4.	Flue gas CO ₂ levels measured at min. and max. load do not match specified levels? ¹⁾ . ▶ Measure CO ₂ levels.	yes:	▶ Adjust CO ₂ levels.
		no:	↓5.
5.	Gas volumetric flow too high when CO ₂ level correctly set ¹⁾ .	yes:	▶ Reduce gas volumetric flow rate by means of adjusting screw on gas valve and/or gas flow restrictor. ▶ Check CO ₂ adjustment.
		no:	↓6.
6.			▶ Change the gas valve.

1) See installation instructions

Ignition too harsh, ignition poor			
	Check		Action
1.	<ul style="list-style-type: none"> ▶ Activate menu option Show service parameters. ▶ Select 5.1 Permanent ignition. Continuous ignition OK?	yes:	↓6.
		no:	↓2.
2.	Ignition lead connected to ignition electrodes?	yes:	↓3.
		no:	<ul style="list-style-type: none"> ▶ Connect cable to ignition electrode. ▶ Press button . Ignition poor? ↓3.
3.	Ignition cable connector engaged in switchbox?	yes:	↓4.
		no:	<ul style="list-style-type: none"> ▶ Power OFF the appliance. ▶ Engage ignition cable connector in switchbox. ▶ Turn ON the appliance. ▶ Press button . ▶ Power OFF the appliance. Ignition poor? ↓4.
4.	Ignition cable defective?	yes:	<ul style="list-style-type: none"> ▶ Power OFF the appliance. ▶ Replace ignition cable. ▶ Turn ON the appliance. ▶ Press button . ▶ Power OFF the appliance. Ignition poor? ↓5.
		no:	↓5.
5.	Electrode assembly defective? <ul style="list-style-type: none"> ▶ Power OFF the appliance. ▶ Remove electrode assembly. Electrodes worn out?	yes:	<ul style="list-style-type: none"> ▶ Replace electrode assembly. ▶ Turn ON the appliance. ▶ Press , does appliance restart??? Ignition poor? ↓6.
		no:	<ul style="list-style-type: none"> ▶ Refit electrode assembly. ▶ Turn ON the appliance. ▶ Press , does appliance restart??? Ignition poor? ↓6.
6.	Does the gas supply type match the specifications on the appliance identification plate?	yes:	↓7.
		no:	<ul style="list-style-type: none"> ▶ Carry out gas type conversion as described in installation instructions. Ignition poor? ↓7.

Ignition too harsh, ignition poor			
	Check		Action
7.	▶ Test gas supply pressure ¹⁾ - OK?.	yes:	↓8.
		no:	▶ Decommission appliance. ▶ Notify gas company.
8.	Problem with flue? ▶ Check CO ₂ level in combustion air. > 0,2 % CO ₂ ?	yes:	▶ Check flue and repair or replace if necessary. Ignition poor? ↓8.
		no:	↓9.
9.	Flue gas CO ₂ levels measured at min. and max. load do not match specified levels. ▶ Measure CO ₂ levels.	yes:	▶ Adjust CO ₂ levels.
		no:	↓9.
10.	Burner not correctly fitted or defective? ▶ Remove burner. Cover fixings not tight or seal defective or not correctly fitted or burner defective.		▶ Replace burner and seal if necessary ▶ Ensure seal is fitted in correct position.

1) See installation instructions

Loose or broken contact on heat store NTC sensor			
	Check		Action
	Heat store NTC sensor lead is not fitted as described in the installation instructions (i.e. the cable does not pass through the cable grip in the switchbox).		▶ Record condition of appliance as found in customer service record. ▶ Route cable as specified in installation instructions.

Text display fails to respond, no display or display incorrect			
	Check		Action
	Ignition lead is not fitted as specified in installation instructions (i.e. the lead should be routed through the clip on the underside of the air box).		▶ Route cable as specified in installation instructions.

Specified CH flow temperature from TA... programmer exceeded		
	Check	Action
	<p>If outside-temperature controlled programmer (TA...) is connected to boiler:</p> <ul style="list-style-type: none"> • The anti-cycle time is adjusted by the programmer to the suit the system. • The factory setting for the anti-cycle time (3 min.) and the heating mode hysteresis setting, if applicable, are deactivated. • In cyclic mode, the switching of the boiler on or off is subject to a time delay in order to prevent divergence between the average CH flow temperature and the specified CH flow temperature. As a result (depending on the heat draw), the specified CH flow temperature is briefly exceeded. In extreme cases, it can happen that the burner does not switch off until the maximum CH flow temperature is reached even though a lower CH flow temperature has been specified. 	
1.	<ul style="list-style-type: none"> ▶ Activate menu option Show service parameters. ▶ Select 2.7 Autom. anti-cycle mode. Read off status of automatic anti-cycle time (0 = Disabled, 1 = Enabled) 	<ul style="list-style-type: none"> ▶ Disable automatic anti-cycle time, i.e. change setting to 0.
2.	<ul style="list-style-type: none"> ▶ Select 2.4 Anti-cycle mode. Read off anti-cycle time setting (0 ... 15 min) 	<ul style="list-style-type: none"> ▶ Set anti-cycle time as required, e.g. factory setting 3 min.

4.5.2 Programmer faults

Set room temperature not reached (TR 2)			
	Check		Action
1.	Thermostatic valve(s) set too low?	yes:	▶ Turn up thermostatic valve(s). ↓2.
		no:	↓2.
2.	CH flow temperature control on boiler set too low?	yes:	▶ Turn up CH flow temperature control.
		no:	↓3.
3.	Air in the heating system.		<ul style="list-style-type: none"> ▶ Power OFF the appliance. ▶ Check appliance and system for water leaks and repair as necessary. ▶ Top up system. ▶ Activate menu option Show service parameters. ▶ Select 7.3 Aeration mode , select setting On, autom. deactivat. and confirm. ▶ Vent appliance¹⁾. ▶ Vent radiators. ▶ Turn ON the appliance.

1) See installation instructions

Set room temperature not reached			
	Check		Action
1.	Thermostatic valve(s) set too low?	yes:	▶ Turn up thermostatic valve(s). ↓2.
		no:	↓2.
2.	Heating characteristic set too low?	yes:	▶ Correct heating characteristic. ↓3.
		no:	↓3.
3.	CH flow temperature control on boiler set too low?	yes:	▶ Turn up CH flow temperature control. ↓4.
		no:	↓4.
4.	Heat store connected via HSM?	yes:	↓5.
		no:	↓6.
5.	Is heat store temperature unreach- able (CH flow temperature control set too low)?	yes:	▶ Turn up CH flow temperature control. ↓6.
		no:	↓6.
6.	Air in the heating system.		<ul style="list-style-type: none"> ▶ Power OFF the appliance. ▶ Check appliance and system for water leaks and repair as necessary. ▶ Top up system. ▶ Activate menu option Show service parameters. ▶ Select 7.3 Aeration mode , select setting On, autom. deactivat. and confirm. ▶ Vent appliance¹⁾. ▶ Vent radiators. ▶ Turn ON the appliance.

1) See installation instructions

Set room temperature exceeded by large amount			
	Check		Action
1.	Do radiators get too hot?	yes:	TR 2: ▶ Decrease setting of "Heating" control ↓2.
		no:	↓2.
2.	Bad choice of location for programmer, e.g. outside wall, near window, in draught, on hollow wall, etc.	yes:	▶ Select better installation location ¹⁾ . ↓3.
		no:	↓3.
3.			▶ Turn down thermostatic valve(s).n

1) See installation instructions

Temperature rises instead of falling			
	Check		Action
	Timer clock (DT 2) incorrectly set		▶ Check setting and correct as necessary.

Room temperature too high in Economy mode			
	Check		Action
	Building retains heat well	yes:	▶ Set economy temperature lower. -or- ▶ Set earlier start time for Economy mode.

Incorrect or no modulation			
	Check		Action
	Programmer incorrectly wired		▶ Check wiring against wiring diagram and correct as necessary.

Heat store fails to heat up			
	Check		Action
1.	with TR 2: CH flow temperature control on boiler set too low.		▶ Increase CH flow temperature control setting.
2.	Hot water temperature control on boiler set too low		▶ Increase hot water temperature control setting.

5 Appendix

5.1 NTC values

5.1.1 Outside temperature sensor

Outside temperature (°C) Measurement tolerance $\pm 10\%$	Resistance (Ω)
-20	2 392
-16	2 088
-12	1 811
-8	1 562
-4	1 342
0	1 149
4	984
8	842
10	781
15	642
20	528
25	436

Table 5

5.1.2 CH flow NTC sensor, heat store NTC sensor, constant hot water NTC sensor and hot water NTC sensor

Temperature (°C) Measurement tolerance $\pm 10\%$	Resistance (Ω)
20	14 772
25	11 981
30	9 786
35	8 047
40	6 653
45	5 523
50	4 608
55	3 856
60	3 243
65	2 744
70	2 332
75	1 990
80	1 704
85	1 464
90	1 262
95	1 093
100	950

Table 6

5.2 Electronic schemes

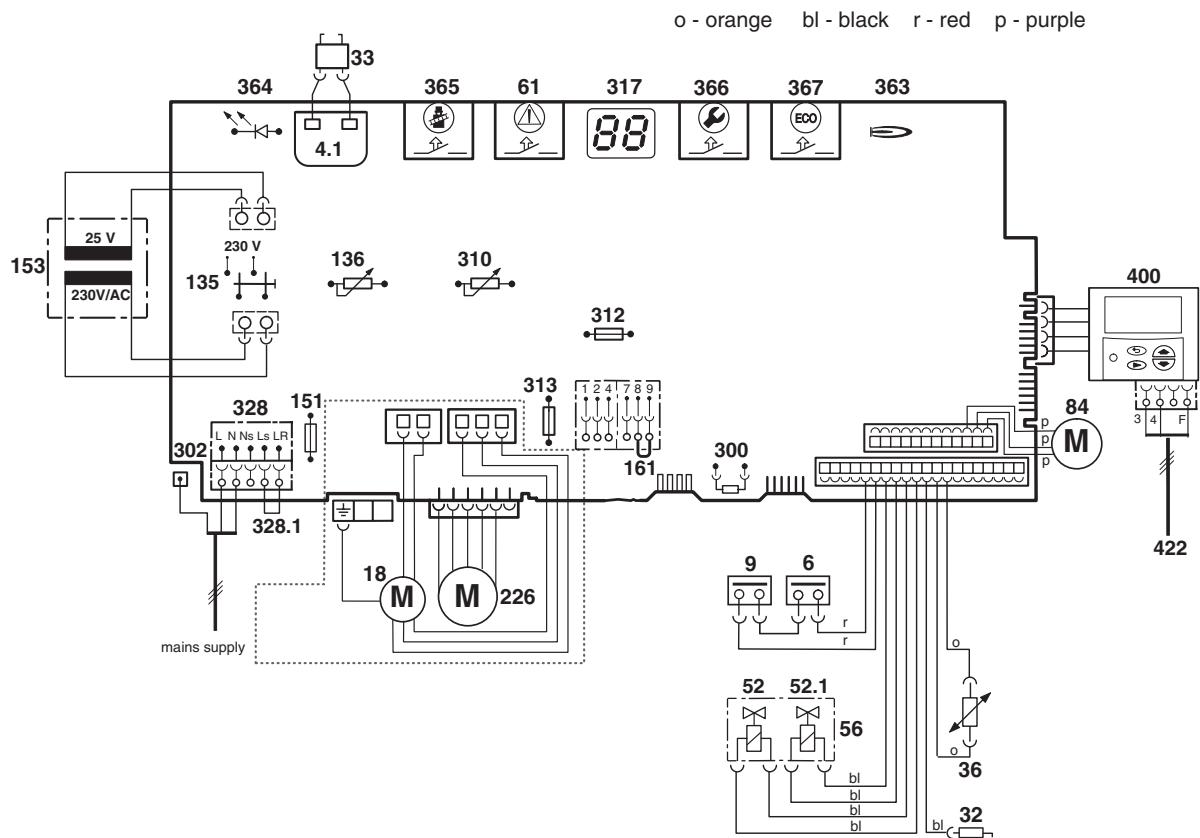

6 720 610 603 - 03.10

Fig. 2

4.1	Ignition transformer	226	Fan
6	Temperature limiter, heat exchanger	300	Code plug
9	Flue gas temperature limiter	302	Earth connection
18	Pump	310	Temperature control for hot water
32	Flame sensing electrode	312	Fuse, slow T 1,6 A
33	Ignition electrode	313	Fuse, slow T 0,5 A
36	Temperature sensor in CH flow	317	Digital display
52	Solenoid valve 1	328	Terminal block for AC 230 V Mains supply
52.1	Solenoid valve 2	328.1	Link
56	Gas valve CE 427	363	Indicator lamp for burner
61	Reset button	364	Indicator lamp for power supply
84	Motor, 3-way valve (ZSBR)	365	"Chimney sweep" button
135	Master switch	366	Service button
136	Temperature control for CH flow	367	ECO button
151	Fuse, slow 2.5 A, AC 230 V	400	Textdisplay
153	Transformer	422	Connecting TR2
161	Link		

5.3 List of most important replacement parts

Component	Order no.	Remarks
Switchbox		
PCB control board	8 748 300 385	
Transformer	8 747 201 358	
Ignition lead	8 714 401 878	
20-pin connector lead assembly	8 714 401 912	
Fuse	1 904 522 730	T 0,5 A
Fuse	1 904 522 740	T 1,6 A
Fuse	1 904 521 342	T 2,5 A
Code plug included in		
Conversion kit G20 -> 31	7 710 149 050	ZWBR 8-30
Conversion kit G31 -> G20	7 710 239 086	ZWBR 11- 30
Conversion kit G20 -> G31	7 710 149 051	ZWBR 11 - 37
Conversion kit G31 -> G20	7 710 239 087	ZWBR 14 - 37
Conversion kit G20 -> G31	7 710 149 052	ZSBR 7-28
Conversion kit G31 -> G20	7 710 239 088	ZSBR 11-28
Conversion kit G20 -> G31	7 710 149 053	ZBR 8-35
Conversion kit G31 -> G20	7 710 239 089	ZBR 11-35
Conversion kit G20 -> G31	7 710 149 046	ZWBR 7-28
Conversion kit G31 -> G20	7 710 239 082	ZWBR 11-35
Conversion kit G20 -> G31	7 710 149 047	ZWBR 11-35
Conversion kit G31 -> G20	7 710 239 083	ZWBR 14-35

Table 7

Component	Order no.	Remarks
Heat exchanger		
Temperature limiter STB	8 729 000 144	110 °C
Flue gas temperature limiter	8 729 000 144	
Temperature sensor, CH flow	8 714 500 054	NTC
Burner		
Electrode assembly	8 718 107 064	
Gas valve		
Gas valve	8 747 003 516	
Gas valve	8 747 003 515	ZBR 11/ 14..42A
Other components		
Fan	8 717 204 325	
Gas supply pipe	8 714 401 885	
Textdisplay	8 747 208 081	
Plate-type heat exchanger	8 715 406 659	ZWBR 7/11-28 A.

Table 7

5.4 Approved corrosion inhibitors and anti-freeze fluids for central heating water

Manufacturer	Description	Remarks	Mixing concentration % by weight
<p>With all anti-freeze fluids and corrosion inhibitors, it is extremely important to observe the manufacturer's recommended concentration levels and to check the concentration regularly.</p> <p>In the case of anti-freeze fluids, it should be noted that the efficiency of fluid-to-fluid heat transfer diminishes as the anti-freeze concentration increases.</p>			
Anti-freeze fluid			
Hüls	Ilexan E	Anti-freeze fluid, equivalent to Antifrogen N.	
Tyforop Chemie GmbH, Hamburg	Tyfocor L	Anti-freeze fluid based on propylene glycol.	25-80
Schilling Chemie	Varidos FSK	Anti-freeze fluid based on ethylene glycol with good corrosion-inhibiting properties. Also suitable for aluminium.	22-55
Hoechst	Antifrogen N	Anti-freeze fluid based on ethylene glycol with good corrosion-inhibiting properties.	20-40
Fernox	Alphi-11	Anti-freeze fluid with corrosion inhibitor, also suitable for aluminium.	
BASF	Glythermin NF	Anti-freeze fluid based on ethylene glycol with good corrosion-inhibiting properties, also suitable for aluminium.	20-62
Corrosion inhibitor			
Schilling Chemie	Varidos KK	Corrosion inhibitor	0,5
Schilling Chemie	Varidos 1+1	Corrosion inhibitor	1-2
Schilling Chemie	Varidos AP	Corrosion inhibitor, also suitable for aluminium.	1-2
Benckiser Wassertechnik	Randophos HS Universal	Corrosion inhibitor	
Geminox, Frankreich	Inibal	Corrosion inhibitor, suitable for aluminium.	1-2
Betz Dearborn, Belgien	Sentinel X 100	Corrosion inhibitor for hot water heating systems, also suitable for aluminium.	1,1
Fernox	Copal	Corrosion inhibitor, also suitable for aluminium.	1
Cillit Wassertechnik	Cillit-HS Combi	Corrosion inhibitor	0,5
Other additives			
Fernox	Restorer Superfloc Universal Cleanser	Cleaning agent (for sludge removal), also suitable for aluminium.	1-2
Fernox	Superconcentrate Central heating Protector	Reduces limescale precipitation, also suitable for aluminium.	

Table 8

5.5 Detecting corrosion by CFCs

Halogenated hydrocarbons in the combustion air cause surface corrosion of the affected metal components. The combustion chamber and the boiler heating surfaces (including stainless steel) are particularly susceptible to this type of attack as are the metal components in the flue socket, flue joints and the chimney.

The presence of halogenated hydrocarbons in the combustion air results in the production of highly caustic hydrochloric acid and - depending on the composition of the combustion air - hydrofluoric acid which build up inside the boiler and remain active over long periods of time.

In order to limit the damage, the source of the contamination must be located and sealed off. If this is not possible, the combustion air must be brought to the appliance from an unaffected area.

Halogens can occur in the following areas:

Industrial sources	
Dry cleaners	Trichloroethylene, tetrachloroethylene, fluorinated hydrocarbons
Degreasing baths	Perchloroethylene, trichloroethylene, methyl chloroform
Printers	Trichloroethylene
Hairdressers	Aerosol propellants, hydrocarbons containing chlorine and fluorine (Freon)
Sources in the home	
Cleaning and degreasing agents	Perchloroethylene, methyl chloroform, trichloroethylene, methylene chloride, carbon tetrachloride, hydrochloric acid
Hobby workshops	
Solvents and thinners	Various chlorinated hydrocarbons
Aerosol sprays	Chlor-fluorinated hydrocarbons (Freons)

Table 9



Worcester Heat Systems Ltd.
Cotswold Way
Warndon
Worcester WR4 9SW
Great Britain

www.thermotechnik.com

Users Instructions and Customer Care Guide



RD 532i/RD 537i/RD 542i combi Condensing boiler
RD 430i system Condensing boiler

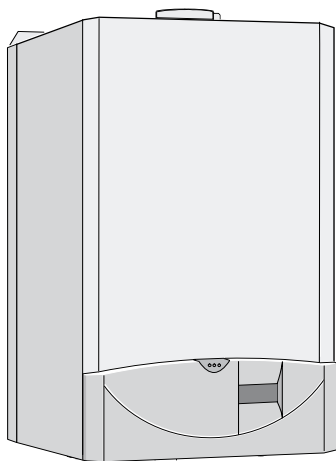

6 720 610 598 - 00.20

ZWBR 7-32 RD 532i GC-Number: 47 108 10

ZWBR 11-37 RD 537i GC-Number: 47 108 11

ZWBR 11-42 RD 542i GC-Number: 47 108 12

System boiler 7-30 RD 430i GC-Number: 41 108 06

benchmark

6 720 610 604 GB (03.06) OSW

British Gas 

Scottish Gas 

Contents

Excellence comes as standard	4
Safety precautions	5
1 General notes	7
2 Controls	11
3 Operating the Appliance	12
3.1 Preparation	12
3.2 Switching the Appliance On/Off	14
3.3 Switching on the Central Heating	15
3.4 Controlling Central Heating	15
3.5 Combination Boilers: Setting Hot Water Temperature	16
3.6 System boiler with Storage Tank	17
3.7 Summer Mode, Hot Water Only (Combi Appliances)	18
3.8 Frost protection (Combi Appliances)	19
3.9 Fault Condition	19
4 Text Display	20
4.1 General Description	20
4.2 Programming	20
4.2.1 Deleting a setting	23
4.2.2 Resetting all parameters to their original settings	23
4.3 Menu structure	24
4.4 Setting the time/day	25
4.4.1 Setting the time and day	25
4.4.2 Holidays	25
4.5 Heating	27

4.5.1 Heating program	27
4.5.2 Setting the Economy temperature (if TR2 is connected)	28
4.5.3 Manual operating mode (if TR2 is not connected)	29
4.6 Hot water	30
4.6.1 Hot water program	31
4.6.2 Hot water immediately (System models)	31
4.7 i Info	32
4.8 Settings	33
4.8.1 Heating (if TR 2 is connected)	33
4.8.2 Hot Water (Storage Tank, System boiler models only)	33
4.8.3 Service	33
4.9 Individual timer programmes	36

5	Fault finding	37
----------	----------------------	-----------

6	Tips on saving energy	38
----------	------------------------------	-----------

7	General Information	39
----------	----------------------------	-----------

8	Maintaining your appliance	40
----------	-----------------------------------	-----------

9	Service	40
----------	----------------	-----------

10	Fault or breakdown	41
-----------	---------------------------	-----------

11	Your guarantee	42
-----------	-----------------------	-----------

12	Guarantee registration	43
-----------	-------------------------------	-----------

13	Operating Instructions Quick Reference	44
-----------	---	-----------

Excellence comes as standard

Thank you for purchasing an RD 532i/RD 537i/RD 542i /RD 430i condensing appliance.

The RD 532i/RD 537i/RD 542i /RD 430i Series has been developed by the Bosch Group and the strictest quality control standards are demanded throughout every stage of production.

Indeed, the Bosch Group have led the field in innovative appliance design and performance for many years.

The result is that your new RD 532i/RD 537i/RD 542i /RD 430i appliance offers you the very best of everything – quality, efficiency, economical running costs, proven reliability and value for money.

What's more, you also have the assurance of our no nonsense 2 year parts and labour guarantee.

And it's backed up by British Gas - Offering a complete maintenance scheme to keep your boiler operating at peak condition and efficiency.

No wonder that more and more people are agreeing that when it is gas, it has to be a British Gas/Scottish Gas Condensing appliance.

Benchmark

The "Benchmark" initiative is the new code of practice to encourage the correct installation, commissioning and servicing of domestic central heating boilers and system equipment.

The "log-book" is a vital document that must be completed by the installer at the time of installation. It confirms that the boiler has been installed and commissioned according to the manufacturers instructions.

Without the completion of the "log-book", manufacturers may refuse to respond to a call-out from a householder, who will be advised that he or she must call back the installer, who has not fulfilled his obligations to record the information required by the initiative.

Safety precautions

Gas Safety (Installation and Use) Regulations 1998

It is the law that all gas appliances are installed by a competent person in accordance with the above regulations. Failure to install appliances correctly could lead to prosecution. It is in your interest, and that of safety, to ensure compliance with the law.

If you smell gas:

- ▶ Turn off gas service cock at the meter.
- ▶ Open all doors and windows.
- ▶ Do not operate any electrical switches.
- ▶ Do not smoke.
- ▶ Extinguish any naked flames.
- ▶ Call your gas company.

If you smell fumes from the appliance:

- ▶ Switch off appliance.
- ▶ Open windows and doors.
- ▶ Inform your heating engineer.

Fitting and modifications

- ▶ Fitting of the appliance or any modifications to the appliance may only be carried out by a competent person.
- ▶ Flue systems must not be modified in any way.

Maintenance

- ▶ We **recommend that you** take out a maintenance contract with a competent installer and have the appliance serviced at regular intervals.
- ▶ Ensure that your Service Engineer uses only genuine spare parts!

Safety precautions

Combustible materials

- ▶ Do not store or use any combustible materials (paper, thinners, paints etc.) in the vicinity of the appliance.

Health and safety

- ▶ This appliance contains no asbestos products.
- ▶ There is no potential hazard due to the appliance being electrically unsafe.
- ▶ There are no substances used in the construction that are a potential hazard in relation to the COSHH Regulations (Control of Substances Hazardous to Health Regulations 1988).

Ventilation Air/Ambient Air

- ▶ Keep ventilation air/ambient air free of corrosive substances (e. g. halogenated hydrocarbons which contain chlorine or fluorine compounds). In this way corrosion can be prevented.

1 General notes

To get the best from your appliance please read these instructions carefully.

Sealed heating systems

The appliance is fitted to a sealed heating system which is pre-pressurised. Your installer will tell you of the minimum and maximum pressure which must be indicated on the pressure gauge.

Check regularly that the pressure is maintained and contact your installer or maintenance engineer if there is a permanent significant drop in the pressure. If the system loses pressure it should be repressurised and the cause of the fall investigated.

Central heating systems

During the first few hours of operation of the central heating system, check that all radiators are being heated at an even rate. If the top of a radiator is at a lower temperature than the bottom then it should be vented by releasing air through the venting screw at the top of the radiator. Ask your installer to show you how this is done. Repeated venting will reduce the quantity of water in the system and this must be replenished for safe and satisfactory operation of the appliance.

Should water leaks be found in the system or excessive venting is required then a service engineer must be contacted to inspect the installation and rectify any fault.

Only additives that are compatible with aluminium may be used in the system. Any incompatible additive used will invalidate the guarantee.

Condensate drain

This is a condensing appliance and the terminal will, at times, give out a plume of water vapour. This is quite normal.

The appliance produces quantities of condensate which is discharged regularly through the siphon.

General notes

Clearances

Your installer will have provided adequate space around the appliance for safety and servicing access. Do not restrict this space with the addition of cupboards, shelves etc. next to the appliance.

Left-hand side	10 mm
Right-hand side	10 mm
In Front	600 mm
Above Casing (Vert. Flue)	75 mm
Above Flue Turret	30 mm
Below	200 mm

Table 1

Room thermostat

A room temperature controller is may be fitted to control the central heating. Refer to the instructions supplied with the thermostat for information on siting and setting.

Cylinder thermostat - System boilers

The cylinder thermostat should be set to 60°C which will be satisfactory for bathing/washing in normal circumstances.

Thermostatic radiator valves

It is recommended that this type of valve is fitted to all the radiators except one, usually the radiator where the room temperature controller is fitted. They should conform to the requirements of BS2767:10.

Showers, bidets, taps and mixing valves – Combination Boilers

Standard hot and cold taps and mixing valves must be suitable for operating at mains pressure. Thermostatically controlled or pressure equalising shower valves will guard against the flow of water at too high a temperature.

Hot and cold mains fed water can be supplied directly to an over-rim flushing bidet subject to local water company requirements.

With all mains fed systems the flow of water from individual taps will vary with the number of outlets operated simultaneously and the cold water mains supply pressure to the property.

Flow balancing using “ball-o-fix” type valves is recommended to avoid an excessive reduction in flow to individual outlets.

For further information contact British Gas Technical Services Department.

Hot and cold flow – Combination Boilers

The flow of water demanded from both hot and cold service outlets is dependent upon the mains supply, it may not be possible in some installations to operate all outlets simultaneously.

Water mains failure – Combination Boilers

If there is a failure of the mains water supply then no water will be available at a tap or shower until the mains supply is restored. The appliance will still operate in the central heating mode.

Use in hard water areas – Combination Boilers

In exceptionally hard water areas a device to prevent scale formation may be fitted. Installation of a scale inhibitor assembly should be in accordance with the requirements of the local water company. An isolating valve should be fitted to allow for servicing.

Alternatively the maximum temperature of the domestic hot water may be reset to about 45 °C which will reduce the risk of scale formation in these hard water areas.

Ventilation

This is a room sealed appliance and does not require any air for combustion from inside the house. If the appliance is fitted into a cupboard or a compartment is built around the appliance after installation then the compartment must be separated from the boiler space by a perforated non-combustible partition as described in BS 6798.

Notwithstanding the requirements of BS 6798, there is no need for ventilation openings to be provided in the compartment because of the low heat loss from the casing.

General notes

Do not allow the flue terminal fitted on the outside wall to become obstructed or damaged.

Pump

The pump is a fully modulating type to which the parameters have been set by the manufacturer and must not be adjusted.

2 Controls

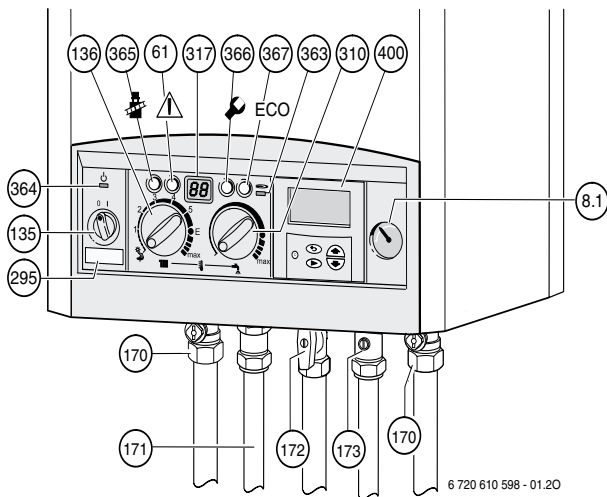

6 720 610 598 - 01.20

Fig. 1

- 8.1** System Pressure gauge
- 61** Reset button
- 135** Master switch
- 136** Central heating temperature control
- 170** Service valves in CH flow and return
- 171** Hot water
- 172** Gas isolation valve (open)
- 173** Cold water inlet
- 295** Identification sticker
- 310** Hot water temperature control
- 317** Display
- 363** Indicator lamp for "burner on"
- 364** Indicator lamp for "off/on"
- 365** "Chimney sweep" button
- 366** Service button
- 367** "ECO" button
- 400** Text Display

3 Operating the Appliance

3.1 Preparation

Turn on the gas cock (172).

- ▶ Press in the handle and turn it anti-clockwise as far as the stop (when handle is in line with direction of flow, the cock is open).

Central heating system valves (170)

- ▶ Using a spanner, turn square nut until groove is in line with direction of flow (see detail).
Groove at right angles to direction of flow = off.

Cold water inlet valve (173)

- ▶ Turn handle so that it is in line with direction of flow.
When handle is at right angles to direction of flow, the valve is closed.

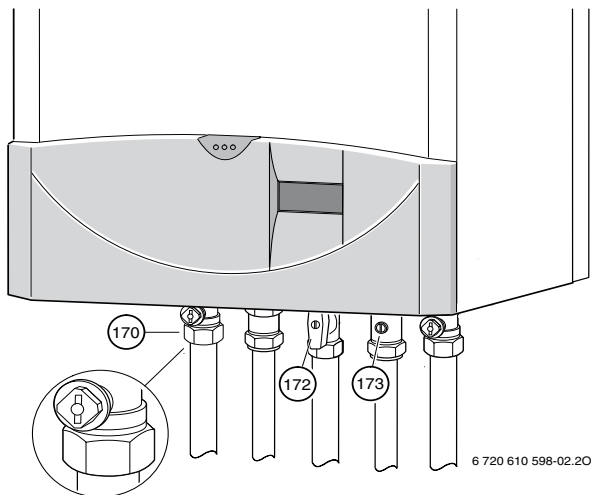

Fig. 2

Check the central heating system pressure

- ▶ The pointer on the pressure gauge (8.1) should be about 1 bar.
- ▶ If the pointer is below 1 bar (when the system is cold), top up the system with water until the pointer is 1 bar. Your installer will have shown you how to do this.
- ▶ The **maximum operating pressure** of 2.5 bar at maximum central heating flow temperature must not be exceeded. If the pressure increases to 3 bar then the relief valve (15) opens.

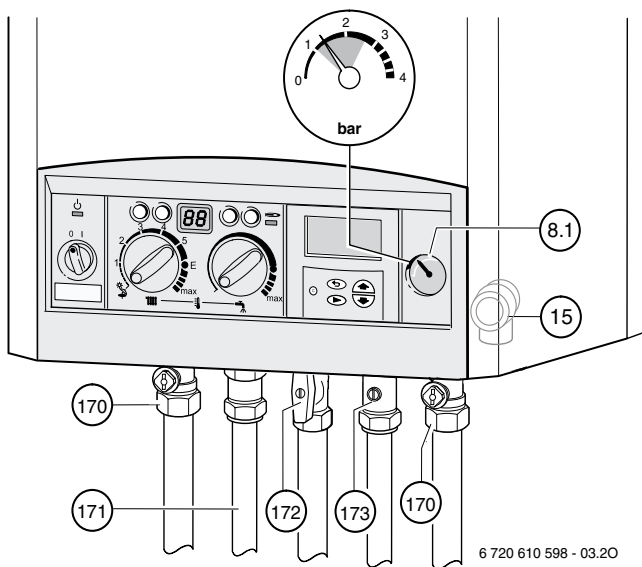

Fig. 3

3.2 Switching the Appliance On/Off

Switching on

- ▶ Switch on the appliance at the master switch (I).
The indicator lamp shows green and the display will show the central heating flow temperature, when the appliance is operating in the central heating mode.

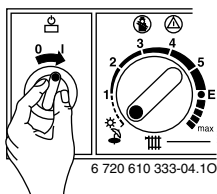

Fig. 4



If the display alternates between **-II-** and the central heating flow temperature, the trap filling programme is active.

The trap filling programme ensures that the condensation trap is filled after the appliance has been installed or after the appliance has been out of use for a long period. For that reason, the appliance remains at minimum heating output for 15 minutes.

Switching off

- ▶ Switch off the appliance at the master switch (0).
The green indicator lamp goes out. The optional timer will continue running until the emergency supply is exhausted.

3.3 Switching on the Central Heating

- ▶ Turn the central heating temperature control  to the desired level:
 - “Min” setting: 35°C
 - Low-temperature heating: setting “E” (approx. 75°C)
 - “Max” setting: 88°C

When the burner is lit, the **red** indicator lamp is illuminated.

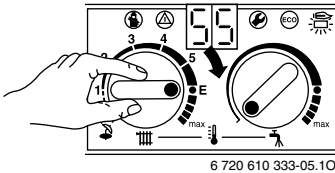



Fig. 5

3.4 Controlling Central Heating

- ▶ Set the timer to the correct time.
- ▶ Set room thermostat to the desired room temperature.
- ▶ Set temperature driven control unit, if fitted. Refer to the instructions with the control.
- ▶ Set the thermostatic radiator valves to the desired settings.

3.5 Combination Boilers: Setting the Hot Water Temperature

Hot water temperature

On combi models, the hot water temperature can be set to between approx. 40°C and 60°C using the temperature control .

The domestic hot water temperature is not shown on the display.

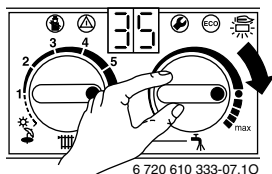

Fig. 6

Control Setting	Water Temperature
Anti-clockwise limit	approx. 40°C
●	approx. 55°C
Clockwise limit	approx. 60°C

Table 2

“ECO” button

By pressing and holding the “ECO” button , until the display lights, you can switch between **Comfort mode** and **Economy mode**.

Comfort mode: button is not lit (factory setting)

The appliance is held constantly at the set temperature. This means that hot water is available almost instantaneously at the tap. Consequently the appliance will switch on at intervals, even if no hot water is being drawn.

ECO mode with demand detection, button is lit

The demand detection function enables maximum gas and water economy.

Briefly turning a hot water tap on and then off again signals demand to the appliance which then heats up the water to the set temperature.

Hot water is thus available in about 1 minute.

ECO mode, button is lit

Water is not heated up until hot water is drawn. This means that there is a longer waiting period before hot water is available.

3.6 System boiler with Storage Tank



- ▶ Do not set the temperature higher than 60°C for normal operation.
- ▶ Only use temperatures of up to 70°C temporarily for thermal disinfection purposes.



With the text display you can additionally set hot water charging times or times and temperatures.

- ▶ Set the hot water temperature by means of the temperature control  on the appliance.

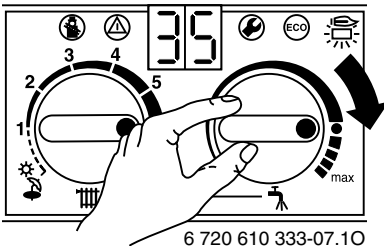



Fig. 7

Control Setting	Water Temperature
Anti-clockwise limit	approx. 10°C (frost protection)
I	approx. 60°C
Clockwise limit	approx. 70°C

Table 3

ECO button

Pressing and holding the ECO button , until it lights up switches from **Comfort mode** to **ECO-mode**.

Comfort mode, ECO button is not lit (factory setting)

In Comfort mode the hot water tank has priority. The hot water cylinder is first heated up to the set temperature. The appliance then switches to central heating mode.

ECO mode, button is lit

In ECO mode the appliance switches between central heating mode and cylinder charging mode every 12 minutes.

3.7 Summer Mode, Hot Water Only (Combi Appliances)

With room temperature controller

- ▶ Turn temperature control  on the appliance anti-clockwise as far as the stop.
The central heating is now turned off. The hot water function and the mains power supply for the heating programmer and timer remain switched on.

3.8 Frost protection (Combi Appliances)

- ▶ Leave master switch switched on.

If the appliance is to be left for long periods switch the central heating on and set the room temperature controller at 6°C.

- ▶ Add a suitable anti-freeze fluid to the water in the central heating system.

Suitable products are available from Betz-Dearborn Tel.: 0151 4209563, Fernox Tel.: 01799 550811 and Salamander Tel.: 0121 378 0952.

3.9 Fault Condition

In the unlikely event of a fault occurring while the appliance is in operation:

The display and the text display then shows a fault code and the button  may also flash.

If the button  flashes:

- ▶ Press and hold the button  until the display shows “- -”.
The appliance will then start up again and the display will show the central heating flow temperature.

If the button  does not flash:

- ▶ Switch the appliance off and then on again at the master switch.
The appliance will start up again and the central heating flow temperature will be displayed.

If the fault remains and can not be cleared:

- ▶ Call British Gas for assistance, giving a description of the fault and, if possible, the fault code from the facia display.

4 Text Display

4.1 General Description

- The text display is used to display information about the appliance and the system and to alter the settings displayed.
- Once the appliance has been in operation for one day, the text display module has a power buffer period of about 10 hours during which it will run without the mains power supply. After that period has elapsed, the clock function shuts down but all other settings are retained.

4.2 Programming

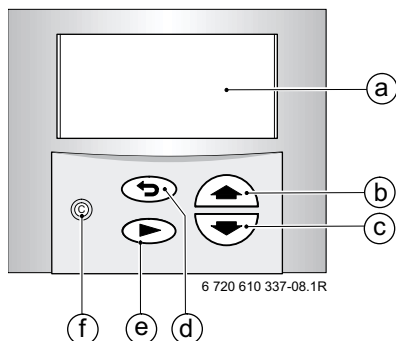

Fig. 8 Controls

- a** Display
- b** "Up"/"More" button
- c** "Down"/"Less" button
- d** "Back" button
- e** "Next" button
- f** "Delete" button

The standard display shows the following information:

- Time
- Room temperature (if TR 2 connected)
- CH flow temperature

- Domestic Hot Water temperature (System boiler if a Storage Tank is accorded).

Additional indication if a special programme is active:

- x holidays
- Hot water immediately
- Constant on (comfort, if TR2 is not connected)
- Constant off (economy, if TR2 is not connected).

Other special operating modes may be displayed during commissioning, servicing, etc.

The programming procedure is described in detail below **using the clock** function as an example:

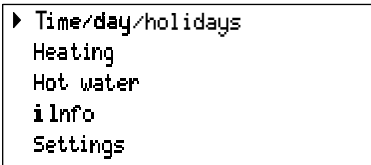

- ▶ To start programming, press any button, e. g. . The display lighting switches on and the main menu is displayed:



```
▶ Time/day/holidays
  Heating
  Hot water
  i l n f o
  Settings
```

6 720 610 598-04.20

Fig. 9 *Main menu*

- ▶ Use the  or  button to move the cursor arrow on the left of the menu so that it points to the desired menu item. In this example, the cursor is positioned next to the menu item **Time/day/holidays**.

Text Display

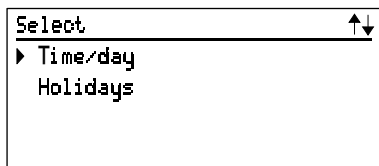

- ▶ Confirm the selection by pressing the  button.
The corresponding submenu is displayed:



6 720 610 598-05.20

Fig. 10 Submenu: Time/day

In the submenus, the top line indicates what action is required. The bottom line shows the previous menu level, if applicable (see Fig. 10).

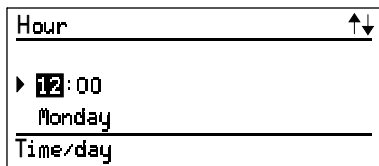

- ▶ Use the  or  button to select **Time/day**.
- ▶ Confirm the selection by pressing the  button.
The corresponding submenu is displayed:









6 720 610 598-06.20

Fig. 11 Setting the hour

When settings are being entered, the setting to be altered is indicated on the top line. In addition, the setting being altered is displayed with a dark background.

- ▶ Use the  or  button to set the hour.
 - Press and release to change the display by one unit at a time
 - Press and hold to change the display rapidly
- ▶ Confirm the setting by pressing the  button.

- ▶ Use the  or  button to set the minutes.
- ▶ Confirm the setting by pressing the  button.
- ▶ Use the  or  button to set the day of the week.
- ▶ Press the  button to confirm the setting. The cursor then returns to the top line.

-or-

- ▶ Press the  button to confirm the setting and return to the previous menu (Fig. 9 page 22).

-or-

- ▶ Do not press any other buttons for 15 minutes.

4.2.1 Deleting a setting

Either overwrite the setting or press the  button to delete it.

- ▶ Find the setting to be deleted.
- ▶ Press and release the  button.
The display shows --:--

4.2.2 Resetting all parameters to their original settings



The hours of service can not be reset to 0.

- ▶ Press and hold the  button for more than 15 seconds. After about 5 seconds, the following message appears on the display:

ATTENTION

Delete all parameters

in x seconds

Once the reset has been completed, the following message is displayed:

Please wait.. Initialising

4.3 Menu structure

Main menu	Submenu			Parameters to change/select	Page
	1.	2.	3.		
Time/day/holidays	Time/day	-	-	- Hours - Minutes - Day of week	25
	Holidays	-	-	Days holiday	25
Heating	Heating program	-	-	- Day - 1st operating mode - 1st switching point ... - 6th switching point	27
	Set economy temp. (if TR2 is connected)	-	-	5...30°C	28
	Manual (if TR2 is not connected)	-	-	- Automatic - Constant on (comfort) - Constant off (economy)	29
Hot water	Hot water program	-	-	- Day - 1st operating mode - 1st switching point ... - 6th switching point	31
	Hot water immediately	-	-	Off/On	31
Info	-	-	-	-	32

Main menu	Submenu			Parameters to change/select	Page	
	1.	2.	3.			
Settings	Heating	-	-	Optimum Start Off/On	33	
	Hot water (System boiler-models)	-	-	Only charging times/times and temperatures	30	
	Service	Display service param.	-	-	-	33
		Further options	Language	-English/ -Français/ -Deutsch	-	34
	-Time correction -LCD contrast			-	34	
	Operating times		-	-	34	
	Fault history		-	-	35	

4.4 Setting the time/day

4.4.1 Setting the time and day

For details of how to set the time and day, refer to page 21.





Changing winter and summer time:

- ▶ Only adjust the clock! Do not alter the switching points (for heating, economy, etc.).

4.4.2 Holidays

In the Holiday programme, the central heating runs in Economy mode and the hot water is switched off (frost protection function remains active).

- ▶ From the main menu, select **Time/day/holidays**, and from the first submenu select **Holidays**.
- ▶ Enter the number of days holiday by pressing  or  (max. 99 days holiday).
After the set number of days, the text display module automat-

Text Display

ically cancels Economy mode at midnight on the last day and returns to Automatic mode.



The day on which you enter the days holiday counts as the first day of the holiday, i.e. the unit starts the holiday program immediately. Only include the day on which you are returning if you **don't** want the heating to return to the normal program on that day!

To cancel Holiday mode early:

- ▶ In the **Holidays** submenu:

Press the  button until the display shows **0** .

4.5 Heating

4.5.1 Heating program

Basic setting (Automatic mode)

- The appliance switches automatically between normal heating, Economy mode and Frost protection mode according to the timer settings entered.
- Basic setting:
 - Heating starts at 6:00 am
 - Economy starts at 10:00 pm



Setting options

- Maximum of six switching points per day with three different operating modes (Heating, Economy, Frost protection).
- Same times for Monday to Friday.
- Same times for Saturday and Sunday.
- Different times for every day.

Setting switching times and operating mode

- ▶ From the main menu select **Heating** and then from the first submenu, select **Heating program**.
- ▶ Select **Monday - Friday**, Saturday and Sunday or an individual day of the week.
 - **Monday - Friday**: to have “Heating” and “Economy” or “Frost protection” switching on at the same times every weekday.
 - **Saturday - Sunday**: to have “Heating” and “Economy” or “Frost protection” switching on at the same times Saturday and Sunday.
 - Individual day of the week (e. g. **Thursday**): to have the relevant program always switching on at the specified time on that day of the week, i.e. “Heating”, “Economy” or “Frost protection” at the same time every Thursday.

Text Display

- ▶ Press . The display shows **Set 1. operating mode**.
- ▶ Set the desired first operating mode (Heating, Economy or Frost protection).
- ▶ Press . The display shows **Set 1. time period**.
- ▶ Set the desired first time period.
- ▶ Press . Set the following operating modes and time periods as described for the first.
- ▶ If necessary: select the next day and enter the operating modes and timer periods as described above.





If the settings for a particular day of the week are different from the settings for the other days, then if **Monday -Friday or Saturday and Sunday** is selected, the display shows **--:--**, i.e. there are no common switching points for those options.

Timer periods and operating modes are you do not wish to change can be skipped by pressing .

4.5.2 Setting the Economy temperature (if TR2 is connected)

This option allows you to set the room temperature for Economy mode (**Off (Economy)**).

This function is only active if:

- Automatic mode or Economy mode is set on the TR 2 room thermostat.
- ▶ From the main menu, select **Heating** and then from the first submenu, select **Set Economy temp..**
- ▶ Use the  or  button to set a temperature between 5 and 30 °C.

4.5.3 Manual operating mode (if TR2 is not connected)

For selecting an operating mode that is different from the one set in the heating programme (**Automatic mode**).

- You can choose between **Automatic**, **Constant on (comfort)** and **Constant off (economy)**.
- The manually selected operating mode starts immediately.
- Constant off (economy) and Constant on (comfort) are automatically reset at 00.00 (midnight).
- To cancel the manually selected operating mode:
 - select the relevant menu and then press the **C** button,
 - or select a different operating mode,
 - or set **Holiday**.
- ▶ From the main menu select **Heating** and then from the first submenu **Manual** select required mode.

4.6 Hot water



General description

- **Combi models only:** The basic settings provide a straightforward timer programme: enabled from 5:00 am, disabled from 10:00 pm. The ECO button must not be lit (Comfort mode).
- **System** models (with Storage Tank): The basic settings provide a timer programme: enable from 5:00 am, disable from 10:00 pm. With the menu **Hot water** (see page 33) you can choose a timer-/temperature programme with the basic settings: 60°C from 5:00 am, 10°C from 10:00 pm.

4.6.1 Hot water program

- Up to six switching points per day can be set.
- There are two operating modes: Blocked and Released.
- ▶ From the main menu, select **Hot water** and then from the first submenu, select **Hot water program**.
- ▶ Set the days of the week, Blocked/Released (operating mode) in the same way as for the switching points and modes for heating as described on page 27.

4.6.2 Hot water immediately (System models)

- **Hot water immediately ON:**
 - Comfort mode is active for 2 hours.
- **Comfort mode is active for 2 hours:** normal automatic program (Hot water mode according to timer programme entered).
- ▶ From the main menu, select **Hot water** and then from the first submenu, select **Hot water immediately**.
- ▶ Press  or  to switch **Hot water immediately** on or off.

4.7 i Info

- ▶ Select **Info** from the main menu.



You can view the following information:

Display text	Description
Room temperature (if TR 2 connected)	Current temperature in the room where TR 2 is installed
Required room temperature (if TR 2 connected)	Required temperature in room where TR 2 is installed
Operating mode (if TR 2 connected)	E. g. Heating, Economy in Automatic mode or Economy, Heating, Frost protection in manual mode
Max. flow temp.	Maximum CH flow temperature set on the temperature control for CH flow
Actual flow temp.	Actual CH flow temperature
Required flow temp.	Required CH flow temperature
Max HW temp.	Maximum permissible hot water outflow temperature
Required HW temp.	Required hot water temperature
Actual HW temp.	Actual hot water outflow temperature
Storage Tank charge released or blocked	Shows, if hot water is released or blocked
Storage Tank charge on or off or Storage Tank charge afterrunning	Shows, if hot water is on or off, or if the pump for the Storage Tank after-running is on
Boiler operat. mode winter/ summer	Indicates which mode the CH flow temperature control is set to
Burner on/off	Indicates whether the burner is alight or not
Pump on/off	Indicates whether the integral pump is switched on or off

4.8 Settings



4.8.1 Heating (if TR 2 is connected)

Optimum Start

- ▶ From the main menu, select **Settings** and from the first sub-menu, select **Heating**.
- ▶ Press  or  to switch Optimum Start on or off.

4.8.2 Hot Water (Storage Tank, System boiler models only)

The text display can control the hot water either with **Times and temperatures** or **only times**.

- **Times and temperatures:** One can choose up to six different times with temperatures, see page 30 “Hot water”.
- **Only times:** During that times the Storage Tank will be charged to the choosed temperature.
- ▶ From the main menu, select **Settings** and from the first sub-menu select **hot water**.
- ▶ Press  or  to switch Times and temperatures or **only times**.



Turn the hot water temperature control  always higher than the temperature at the text display is choosen.

4.8.3 Service

Displaying service functions



This option displays various current settings and statuses of the electrically controlled appliance and system components for the benefit of the heating engineer.

Text Display

Service parameters

Language







Available languages are: English, Français (French), Deutsch (German).

- ▶ From the main menu, select **Settings**, from the first submenu select **Service**, from the Second submenu select **Further options**, and from the third submenu select **Language**.
- ▶ Press  or  to select the desired language.

Two other supplementary functions can be selected from the third submenu Language:







- Time correction
- LCD contrast.

Time correction:

- ▶ Press and hold the  button (about 5 seconds) until the display shows **Time correction and LCD contrast**.
- ▶ Press  or  to select **Time correction**.
- ▶ Press the  button. The display shows **Change value**.
- ▶ Press  or  to set the number of seconds in 24 hours.

Basic setting: “+ 0 s”

LCD contrast:

- ▶ Press and hold the  button (about 5 seconds) until the display shows **Time correction and LCD contrast**.
- ▶ Press  or  to select **LCD contrast**.
- ▶ Press the  button. The display shows **Change value**.
- ▶ Press  or  to adjust the **LCD contrast**.

Basic setting: e. g. “47”

Operating times

This option shows the hours of service (appliance, burner and hot

water) since commissioning.

- ▶ From the main menu, select **Settings**, from the first submenu select **Service**, from the Second submenu select **Further options**, and from the third submenu select **Operating times**.

Fault history

This option displays any faults that have occurred for the information of the service engineer. The first fault displayed may still be active. Any other faults displayed are no longer active.

- ▶ From the main menu, select **Settings**, from the first submenu select **Service**, from the Second submenu select **Further options**, and from the third submenu select **Fault history**.

4.9 Individual timer programmes

Heating periods for central heating												
Switching point	1.		2.		3.		4.		5.		6.	
Status	Operating mode	Time	Operating mode	Time	Operating mode	Time	Operating mode	Time	Operating mode	Time	Operating mode	Time
Monday												
Tuesday												
Wednesday												
Thursday												
Friday												
Saturday												
Sunday												

Enable/disable hot water function												
Switching point	1.		2.		3.		4.		5.		6.	
Status	Operating mode	Time	Operating mode	Time	Operating mode	Time	Operating mode	Time	Operating mode	Time	Operating mode	Time
Monday												
Tuesday												
Wednesday												
Thursday												
Friday												
Saturday												
Sunday												

5 Fault finding

Problem	Cause	Remedy
Desired room temperature is not reached	Thermostatic valve(s) set too low	Increase thermostatic valve setting(s)
	Temperature control for CH flow set too low	Increase CH flow temperature control setting
	Air trapped in heating system	Bleed radiators and heating system
Desired room temperature exceeded by large amount	Radiators are too hot	Turn down thermostatic valves
Temperature rises instead of falling	Clock is incorrectly set	Check setting
Room temperature too high in Economy mode	Building retains heat well	Start Economy mode sooner
No display or display unit does not respond	Momentary power failure	Switch off appliance at master switch, wait a few seconds and switch on again
Storage Tank doesn't warm up	Temperature control is too low	Turn the temperature control to the desired temperature

6 Tips on saving energy

Heating economically

The boiler is designed to provide a high level of comfort while keeping gas consumption and the resulting environmental effect as low as possible. The gas supply to the burner is controlled according to the level of demand for heat. The boiler continues to operate with a low flame if the demand for heat reduces. The technical term for this process is modulating control. Modulating control keeps temperature fluctuations small and provides even distribution of heat throughout the home. This means that the boiler may stay on for relatively long periods but will use less gas than an appliance that continually switches on and off.

Central heating systems with room thermostats/thermostatic radiator valves

The central heating control on the boiler should be set to the maximum rated temperature of the central heating system or to position "E", when the maximum central heating water temperature obtained is 75°C.

The temperature can be set individually in each room (except primary room with the room thermostat) using the thermostatic radiator valves. If you wish to have a lower temperature in the primary room than in the other rooms, leave the room thermostat at the set temperature and turn down the radiator using the radiator valve.

Reduced-output operation

Considerable fuel savings can be made by slightly reducing the room temperature. Lowering the temperature by 1 °C can bring about energy savings of up to 5 %. However, it is not advisable to allow any room temperature to fall below +15 °C. The room temperature for reduced-output mode can be set separately on the room thermostat. Instructions are given in the control unit operating instructions.

Hot water

A lower setting on the hot water temperature control can result in considerable energy savings.

For combi appliances:

The **on-demand activation** using the ECO-button makes possible the maximum savings of gas and water.

Now you know how to heat your home economically with the RD 532i/RD 537i/RD 542i /RD 430i gas condensing boiler. If you have any other questions, please contact your installer – or write to us.

7 General Information

Cleaning the Outer Case

Wipe down the outer case with a damp cloth. Do not use abrasive or caustic cleaning agents.

Appliance details

If you ever need to call Customer Service it helps us a great deal if you can provide precise details of your appliance.

The information is printed on the appliance identification plate/ sticker (see page 11, item 295).

Your installer will have completed the Benchmark “log-book” giving details of the boiler together with name, address and registration number. Have the “log-book” to hand when calling a Service Engineer.

8 Maintaining your appliance

Your new RD 532i/RD 537i/RD 542i /RD 430i gas-fired appliance represents a long-term investment in a reliable, high quality product.

In order to realise its maximum working life, and to ensure it continues to operate at peak efficiency and performance, it is essential that your boiler receives regular, competent servicing and maintenance checks beyond the initial 2 year guarantee period.

To arrange for a British Gas three star cover agreement please call 0845 9 60 50 40.

9 Service

If your RD 532i/RD 537i/RD 542i /RD 430i appliance should fail to operate correctly or requires servicing please call British Gas on: 0845 9 60 50 40.

10 Fault or breakdown

This product is supported in the UK by Worcester Heat Systems Ltd. – part of the Bosch Group.

A specialist factory trained field SERVICE ENGINEER is available to attend a breakdown or manufacturing fault occurring on this appliance.

No charge will be made for parts and/or labour providing:

- An appliance fault is found and the appliance has been installed within the past 24 months. Reasonable evidence of this must be supplied on request.

A call-out charge will be made where:

- The appliance has been installed for over 24 months.
OR
- Our Field Service Engineer finds no fault with the appliance (see **NOTE**).
OR
- The cause of breakdown is misuse or with other parts of your plumbing/heating system, or with equipment not supplied by Worcester.

NOTE: No appliance fault is found on over 30 % of all service call outs.

If in doubt contact our British Gas on 0845 9 60 50 40.

IN THE EVENT OF AN APPLIANCE FAULT OR BREAKDOWN

please contact your Service Centre (see over). Your service administrator will arrange for an engineer to call with the minimum of delay; under normal circumstances this will be within the period 1-3 working days (excluding weekends) for priority breakdown situations (no hot water and/or heating service).

INVOICES FOR ATTENDANCE AND REPAIR WORK CARRIED OUT ON THIS APPLIANCE BY ANY THIRD PARTY WILL NOT BE ACCEPTED.

11 Your guarantee

This appliance is guaranteed against faulty material or workmanship for a period of 24 calendar months from the date of installation subject to the following conditions and exceptions.

- That during the currency of this guarantee any components of the unit which are proved to be faulty or defective in manufacture will be exchanged or repaired free of material charges and free of labour charges by Worcester Heat Systems Limited.
- That the householder may be asked to prove the date of installation, that the appliance was correctly commissioned and, where appropriate, the first 2 year service has been carried out to the satisfaction of Worcester Heat Systems Limited when requested.
- That any product or part thereof returned for servicing under the guarantee any components of the unit which are proved to be faulty guarantee must be accompanied by a claim stating the Model, Serial Number, Date of Installation.
- That Worcester Heat Systems Limited will not accept responsibility for damage caused by faulty installation, neglect, misuse or accidental damage, the non observance of the instructions contained in the Installation and Users Instructions Leaflets.
- That the appliance has been used only for normal domestic purposes for which it was designed.
- That this guarantee applies only to equipment purchased and used in Great Britain.

This guarantee is given in addition to all your normal statutory rights.

12 Guarantee registration

You should complete and return the postpaid Guarantee Registration Card within 14 days of purchase.

The card will register you as the owner of your new RD 532i/RD 537i/RD 542i /RD 430i appliance and will assist us in maintaining an effective and efficient customer service by establishing a reference and permanent record for your boiler.

This will not affect your statutory rights in any way.

Important:

For your own record:

Model

.....

Serial number:.....

(See identity label inside appliance casing)

Type/size:.....

Date of installation:.....

Check that the Benchmark “log-book” has been completed by your installer or service engineer.

SERIAL NUMBER. Copy the number off the Guarantee Card.

13 Operating Instructions Quick Reference

Switching on

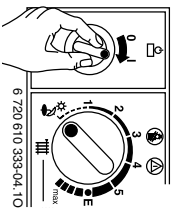

Switching the central heating on

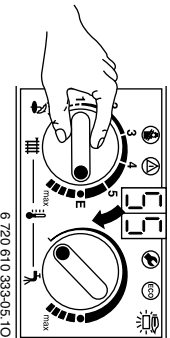

Text Display

Set switching times and operating mode within the text display.

Hot water temperature – Combination boiler only

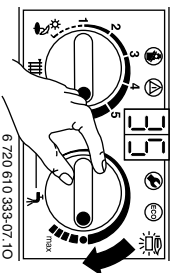

“ECO”-button lit –

Economy mode.

“ECO”-button not lit –

Comfort mode

Fault Condition

Refer to page 19.

Switching off

