

Atmos InterOpen

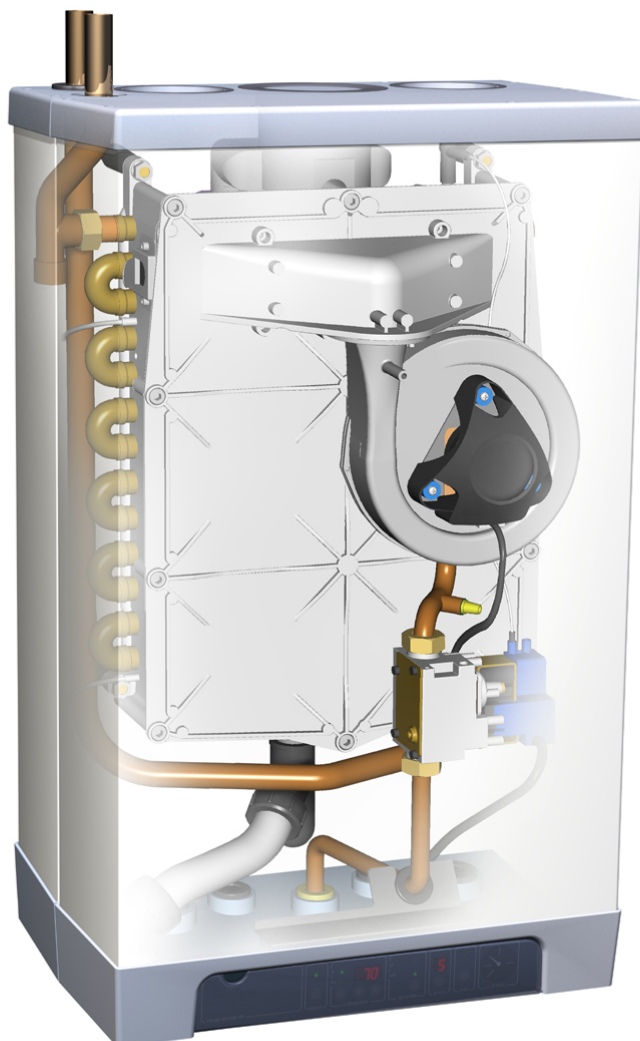

Installation Instructions for HE22

Atmos Heating Systems
West March
Daventry

Northants, NN11 4SA

Tel: 01327 871990

Fax: 01327 871905

e-mail: sales@atmos.uk.com

internet: www.atmos.uk.com

Issue 07.10.05

(First Applicable Serial Number 0505 021 642 [single unit] & then 0510 048 316)

TABLE OF CONTENTS

1. Safety Regulations	6
1.1 General	6
1.2 CH system.....	6
1.3 Gas system	6
1.4 Electrical system	6
1.5 Domestic water system	6
1.6 Flue discharge and air supply	6
2. Description of the Appliance	7
2.1 General	7
2.2 Operation	7
2.3 Operating conditions	7
2.4 PC interface	9
2.5 Test programmes	9
2.5.1 Frost protection	9
3. Main Components	10
3.1 Accessories.....	11
4. Installation	12
4.1 Overall dimensions.....	12
4.2 Unpacking the appliance.....	13
4.3 Additional dimensions	13
4.4 Boiler location.....	14
4.4.1 Installation in a kitchen cupboard	14
4.4.2 Installation in an airing cupboard.....	14
4.4.3 Remove front panel	14
4.5 Mounting	15
4.5.1 Fitting the mounting strip	15
4.5.2 Fitting the rear mounting frame	15
4.6 Mount the appliance	16
4.7 Fit the pipework cover (optional)	16
5. Connections	17
5.1 Connect the CH system	17
5.1.1 Thermostatic radiator valves	17
5.1.2 System bypass	17
5.2 Connecting the gas supply	17
5.3 Electrical connection	18
5.3.1 24V dc Electrical connections	19
5.3.2 Volt free Room thermostat on/off	19
5.3.3 230Vac Electrical connections	19
5.4 General Flue Requirements	20
5.4.1 Flue terminal clearances	20
5.4.2 Flue system.....	20
5.5 Flue discharge and air supply	21
5.5.1 Twin-pipe connection	21
5.5.2 Vertical Concentric connection.....	21
5.5.3 60/100mm Concentric Standard through the wall Horizontal Terminal	22
5.6 Pipe lengths and details	23
5.6.1 Equivalent lengths	23
5.6.2 Example of 80mm twin pipe calculation	23
5.6.3 Example of 80/125mm concentric pipe calculation	23
5.6.4 Pipe, materials and insulation	24
5.6.5 Outlet arrangements.....	24
5.6.6 Flue discharge pipe and air supply pipe.....	24
5.7 Outside wall outlet for twin pipe terminal - horizontal	25



5.8	Outside wall and roof outlet concentric terminal horizontal	27
5.9	Roof outlet combination and twin pipe terminal - vertical	28
5.10	Roof outlet prefabricated chimney.....	31
5.11	Roof outlet and air supply from the outside wall.....	32
5.12	Air supply from the outside wall and a roof outlet with common discharge system.....	33
5.13	Roof outlet CLV system	34
6.	Commissioning	35
6.1	Fill and de-aerate the appliance and the system.....	35
6.1.1	CH system.....	35
6.1.2	Gas supply	35
6.2	Commissioning of the appliance/ system.....	36
6.3	System Shutdown	37
6.3.1	Frost protection	37
7.	Setting and Adjustment	38
7.1	Directly via operating panel.....	38
7.2	Settings through the service code	38
7.3	Parameters.....	39
7.4	Setting maximum CH power.....	40
7.5	Setting pump power	40
7.6	Conversion to other gas type	41
7.7	Gas-air control.....	41
7.8	Setting gas-air control	42
8.	Faults	44
8.1	Burner does not ignite	45
8.2	Burner ignites with much noise	45
8.3	Burner resonates.....	46
8.4	No heating (CH)	46
8.5	Reduced output.....	47
8.6	CH does not reach the correct temperature	47
9.	SERVICING THE BOILER	48
10.	Technical Specifications	49
10.1	Electrical diagram.....	50
11.	CE Declaration	51

© 2005 Atmos Heating Systems

The information provided applies to the product in the standard model. Atmos Heating Systems can therefore not be held liable for any damage resulting from the product specifications that deviate from the standard model.

The information provided has been compiled with the utmost care. However, Atmos Heating Systems cannot be held liable for any faults in the information nor for the consequences thereof.

Atmos Heating Systems cannot be held liable for any damage resulting from the activities carried out by third parties.

To be changed without prior notice

This manual

Using this manual you can safely install and maintain this appliance.
Carefully follow the instructions.

In case of doubt, contact Atmos Heating Systems.

Keep these instructions near the appliance.

Abbreviations and names used

Description	To be referred to as
High Efficiency	HE
Atmos InterOpen wall-mounted gas heater	Appliance
Appliance with piping for central heating	CH system

Icons

The following symbols are used in this manual:-



CAUTION

Procedures that, when not carried out with due care, may result in damage to the product or the environment or in personal injury.

Service and technical support

For information about specific adjustments, installation, maintenance and repair activities, please contact:

Atmos Heating Systems,
West March,
DAVENTRY,
Northants, NN11 4SA
www.atmos.uk.com

Guarantee conditions

Considering the conditions mentioned below, Atmos guarantees towards the recognised installer the soundness of the materials used, as well as the good operation of its Central Heating products, if applied for their intended use. When the occasion arises, we should be given the opportunity to ascertain ourselves, if necessary on the spot, of the validity of the guarantee claim.

The guarantee includes:

1. The guarantee is limited to the free redelivery of the parts showing material or manufacturing faults that are not the result of normal wear and the like during the guarantee period, entirely at our discretion. These parts should be returned to us prepaid mentioning the defect and they will be our property after replacement.
2. The guarantee period for parts is 2 years as from the date of installation. However, the following parts have been excluded from guarantee: ignition probe, ionisation pin, glass fuse, thermocouple and de-aerator.
3. The period of guarantee for the heat exchanger of the appliance is 5 years, provided that if corrosion leaks occur that can, at our discretion, not be remedied on the spot, we only deliver this part of the boiler for a fee of old for new, calculated from the installation date at the time of replacement.
4. A copy of the completed Benchmark Boiler Commission Certificate must be returned as proof of correct commissioning.
5. The guarantee shall no longer be valid when it is established that the defects, damage or excessive wear are due to improper use or injudicious treatment or to unskilful repair, adjustment, installation or maintenance by non-approved installers.
6. The guarantee is no longer valid when the defect is the result of deposition of scale (harmful to the appliance and the system). Surface damage and transport damage are outside the scope of the guarantee. The right to guarantee lapses if the boiler has not had a yearly service by an approved service agent. The instructions of installation and use that we supply for the respective appliances must be fully observed.
7. The guarantee is only valid if the return slip of the certificate of guarantee has been returned to us within 8 days after the installation, signed by the buyer. By signing the guarantee card, the buyer declares that he agrees with the good state of the delivery.
8. If the installer's company was terminated before expiration of the guarantee period, the user can make an appeal to our guarantee obligations towards the installer.

Environment



When the appliance needs replacement, your installer may arrange for disposal. Should this not be possible, then make enquiries with your local council about the possibilities for re-use or environmental-friendly processing of the materials used, or contact a scrap dealer about disposal.

Various plastics and metals have been used in producing the appliance. Also, the appliance contains electronic components that are electronic waste.

Intended use

The appliance as described in this documentation is intended for heating rooms with a central heating system and, if required, heating hot water via an indirect hot water tank. Any other use is outside the scope of intended use for this appliance. Any liability for damage resulting from improper use shall not be accepted.

1. SAFETY REGULATIONS

The appliance must be installed in accordance with the Gas Safety (Installation and Use) Regulations; October 1994. Failure to install appliances correctly could lead to prosecution.

Atmos Heating Systems does not accept any liability for damage or injury caused by not (strictly) observing the current safety regulations and instructions, nor by negligence while installing the Atmos InterOpen wall-mounted gas heater and any accompanying accessories.

The manufacturer's instructions must NOT be taken as overriding statutory requirements.

The regulations are mentioned separately for the different disciplines.

1.1 General

The entire system should comply with the valid (safety) regulations, as mentioned in:-

- This installation manual.
- Gas Safety (Installation and Use) Regulations
- The appropriate Building Regulations.
- Health and Safety Document No 635 (Electricity at Work Regulations)
- The Water Fittings Regulations or local Water byelaws.

1.2 CH system

The entire system should comply with the valid (safety) regulations, as mentioned in:-

- BS 5449 Central Heating for Domestic Premises.

1.3 Gas system

The entire system should comply with the valid (safety) regulations, as mentioned in:-

- BS 6798 Specification for installation of gas fired hot water boilers of rated input not exceeding 60 kW.
- BS 6891 Installation of low pressure gas pipework installations up to 28mm (R1).
- I.S.813 Installation of Gas Appliances (for installations in Ireland).
- British Gas Guidance Notes for the Installation of Domestic Gas Boilers.

1.4 Electrical system

The entire system should comply with the valid (safety) regulations, as mentioned in:-

- BS 7671 The IEE Wiring Regulations.

1.5 Domestic water system

The entire system should comply with the valid (safety) regulations, as mentioned in:-

- BS 5546 Installation of gas hot water supplies for domestic purposes.

1.6 Flue discharge and air supply

The flue discharge and the air supply system should comply with:-

- BS 5440 Flues and Ventilation for gas appliances of rated input not exceeding 60 kW. (Part 1 Flues and Part 2 Ventilation).

2. DESCRIPTION OF THE APPLIANCE

2.1 General

The Atmos InterOpen wall-mounted gas boiler is a balanced flue appliance suitable for open vent systems with a header tank. The appliance is designed for delivering heat to the water of a CH system and heating hot water via an indirect hot water tank.

The air supply and flue discharge can be connected to the appliance by means of two separate pipes or a concentric connection.

The appliance has its own wall mounting strip, but can also be fitted to an optional wall mounting frame that allows top connection of gas pipe.

The Atmos InterOpen wall-mounted gas boiler has the CE quality mark and the Gas certification labels HE (Sedbuk B) and IP44.

The appliance as delivered is suitable for natural gas (G20). A conversion kit for propane (G31) can be supplied upon request.

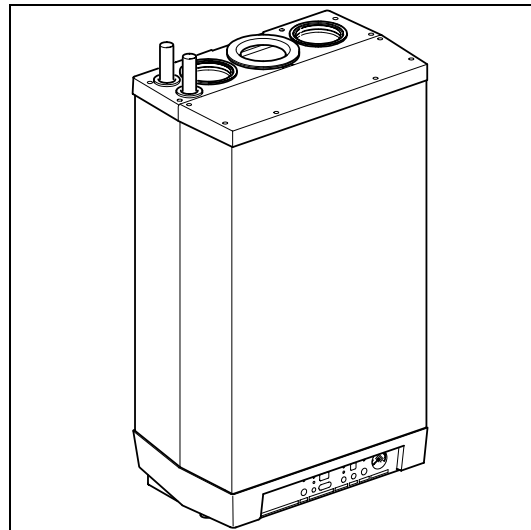

2.2 Operation

The Atmos InterOpen wall-mounted gas heater is a modulating high efficiency boiler. This implies that the power is adjusted to the heat demand.

In the aluminium heat exchanger is an integrated copper circuit.

The appliance has been provided with an electronic burner controller that controls the fan with the heat demand from the heating system or the hot water supply, opens the gas valve and ignites the burner and continuously monitors the flame and controls it dependent on the power required.

2.3 Operating conditions

A code indicates the operating condition of the appliance on the service display of the operating panel.

Off

The appliance is not operating, but there is electrical power. There is no response to any demand for hot domestic hot water or CH water. The frost protection is active though. This means that the pump starts running and the heat exchanger is heated when the temperature of the water present here drops below 4 °C. When the frost protection is activated, code 7 appears (heating of the heat exchanger).

Waiting position

The LED of the on/off key is on. The appliance is ready for responding to the demand for CH or domestic hot water.

0 Pump overrun

After the operation of the CH, the pump has an overrun. This overrun time is set to the value according to parameter 8 at the factory. This setting can be changed. Also, the controller will automatically run the pump for 10 seconds, once every 24 hours, to prevent it from getting stuck. This activation of the pump takes place at the time of the last heat demand 24hrs later. In order to change this time, set the room thermostat higher for a while at the desired time.

Note

Pump overrun is only available if the pump output is used (terminal X2/8) – see also §5.3.3.

1 Required temperature reached

The burner controller can temporarily block the heat demand and stop the burner. This blocking takes place because the required temperature has been reached. When the temperature has dropped sufficiently, the blocking is cancelled.

2 Self-test

The burner controller regularly checks the connected sensors. During the check, the controller does not carry out any other tasks.

3 Ventilate

When starting the appliance, the fan is first brought to the starting speed. When the fan reaches the starting speed, the burner is ignited. Code **3** is also visible when, after stopping the burner, post-purge takes place.

4 Ignite

When the fan has reached the ignition speed, the burner is ignited by means of electric spark ignition. During ignition the code **4** appears. If the burner is not ignited, another ignition attempt is made after about 5 seconds. If the burner has still not fired after the fourth ignition attempt, the controller indicates a fault. See § 8.1.

5 CH operation

An on/off thermostat can be connected to the controller. See the Electrical diagram §10.1. When heat is demanded by a thermostat signal, the fan runs (code **3**) and the burner is ignited (code **4**), followed by the CH operating condition (code **5**).

During CH operation, the fan speed and hence the power of the appliance is adjusted. This is done in such a way, that the temperature of the CH water is controlled towards the set CH supply temperature. In the case of an on/off thermostat, the CH supply temperature is set at the operating panel.

During CH operation, the demanded CH supply temperature is displayed on the operating panel.

During CH operation, the CH supply temperature can be set between 30°C and 90°C and the set CH supply temperature is displayed on the operating panel. During CH operation, the actual CH supply temperature can be read by pressing the service key.

2.4 PC interface

The controller has an interface for a PC. With a special cable and accompanying software, a PC can be connected. This provision makes it possible to follow the behaviour of the controller, the appliance and the heating system during a long period.

2.5 Test programmes

In the burner controller, there is provision for putting the appliance into a test status.

By activating a test programme, the appliance will become active with a fixed fan speed without intervention of the control functions. The safety functions remain active though.

Simultaneously press + and - to switch off the test programme.

Test programmes

Description of programme	Key combinations	Display reading
Burner on with minimum CH power	"service" and "-"	"L"
Burner on with maximum CH power	"service" and "+" (1x)	"h"
Burner on with maximum power (set by parameter 4)	"service" and "+" (2x)	"H"
Switch off test programme	"+" and "-"	Current operating condition

2.5.1 Frost protection

The boiler has provision for protecting its heat exchanger as described below.

NOTE! However to avoid the condensate freezing, the boiler must be installed in a FROST-FREE room.



- In order to avoid freezing of the appliance (heat exchanger), it has an appliance frost protection. When the temperature of the heat exchanger drops to 5°C, the burner will be activated and the pump will start running until the temperature of the heat exchanger reaches 10°C. Code 7 is given when the appliance frost protection intervenes (heating heat exchanger).
- When the system (or a part thereof) can freeze, a frost thermostat should be installed in the area to be protected. Connect this according to the wiring diagram. See § 10.1.

Remark

When the appliance is out of action (- on the service display), the appliance frost protection is still active. However, there will be no response to heat demand from an (external) frost thermostat.

3. MAIN COMPONENTS

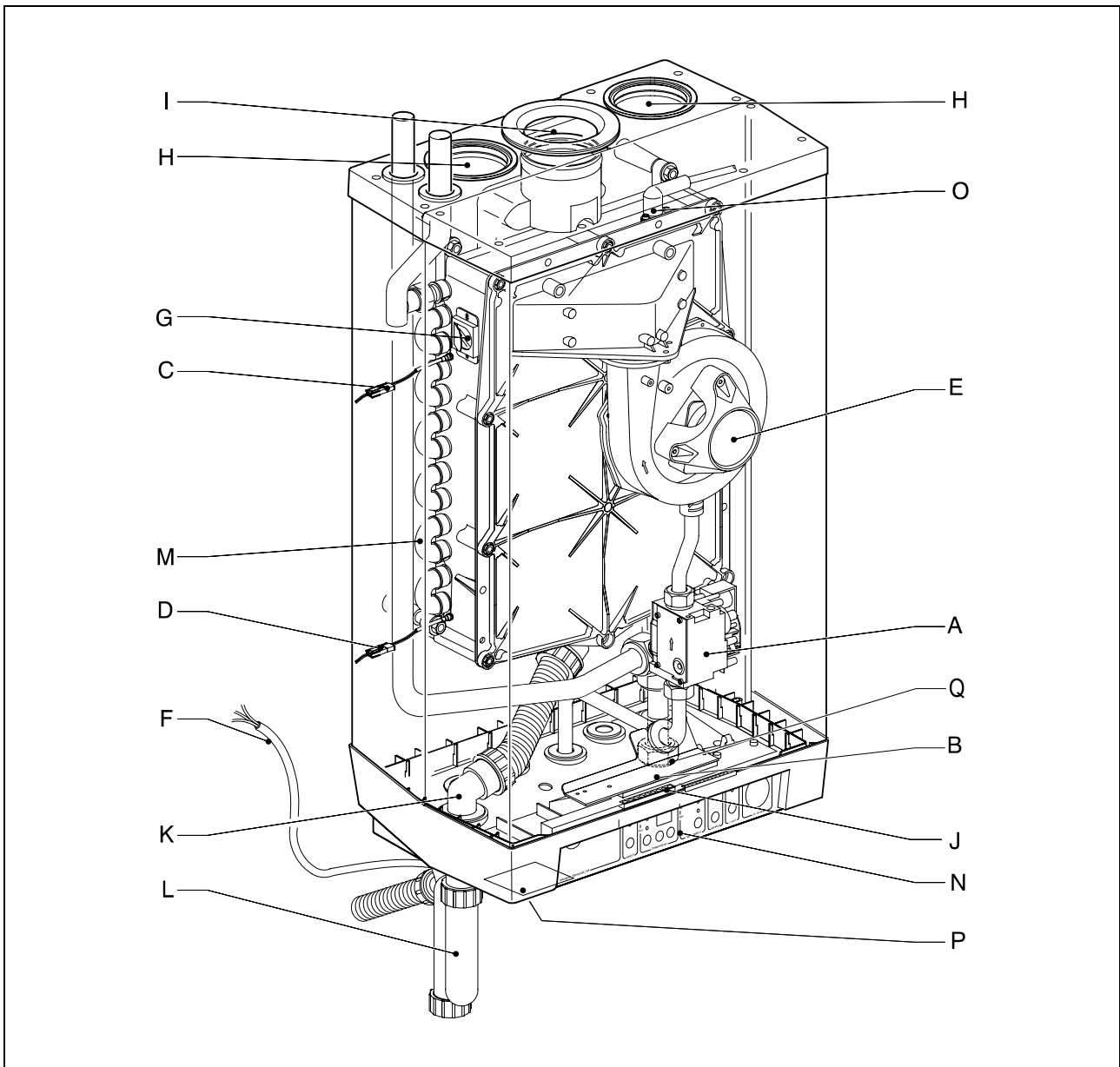

- | | | | |
|---|--|---|---|
| A | Gas valve | I | Flue discharge (or concentric connection) |
| B | Burner controller with operating panel | J | Connecting block / terminal list X |
| C | Supply sensor S1 | K | Condensate discharge |
| D | Return sensor S2 | L | Siphon |
| E | Fan | M | Heat exchanger |
| F | 1m connecting cable 230 V ~ | N | Operating panel and display |
| G | Sight glass and mirror | O | Ionisation/ignition probe |
| H | Air supply (left or right) | P | Position type plate |
| | | Q | Drain valve |

Additional Components supplied :-

Valve set (supplied separately with boiler)



3.1 Accessories

Description	
Rear mounting frame for top pipe connection	
Pipework cover	
Conversion set to Propane (LPG or G31)	
Interface cable	

4. INSTALLATION

4.1 Overall dimensions

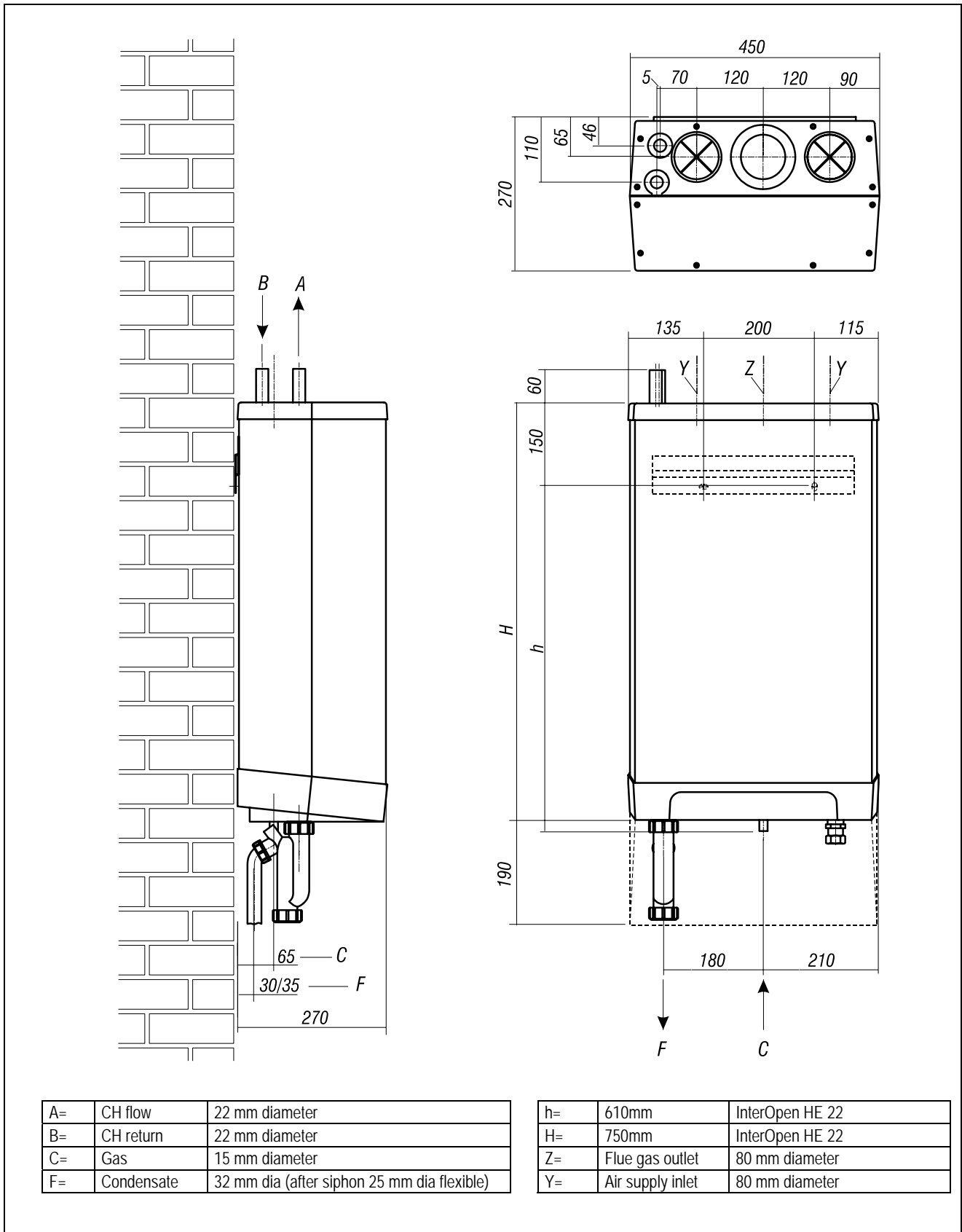

4.2 Unpacking the appliance

1. Unpack the appliance.
2. Check the content of the packaging. This consists of:-
 - Appliance (A)
 - Mounting strip (B)
 - Siphon (C)
 - Installation instructions
 - Guarantee card
3. Check the valve set (supplied separately with boiler).
4. Check the appliance for any damage: report damage to the Supplier immediately.

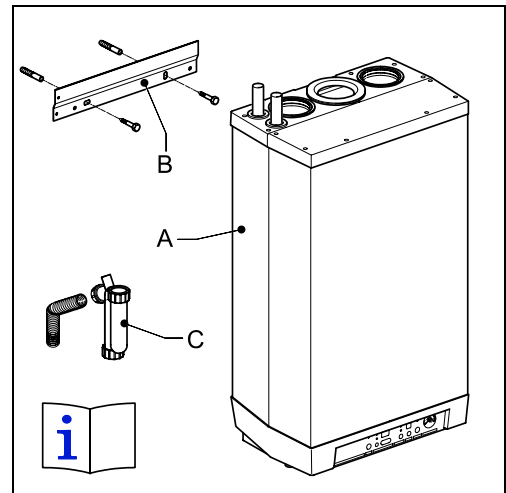

4.3 Additional dimensions

The diagram shown below gives additional dimensions.

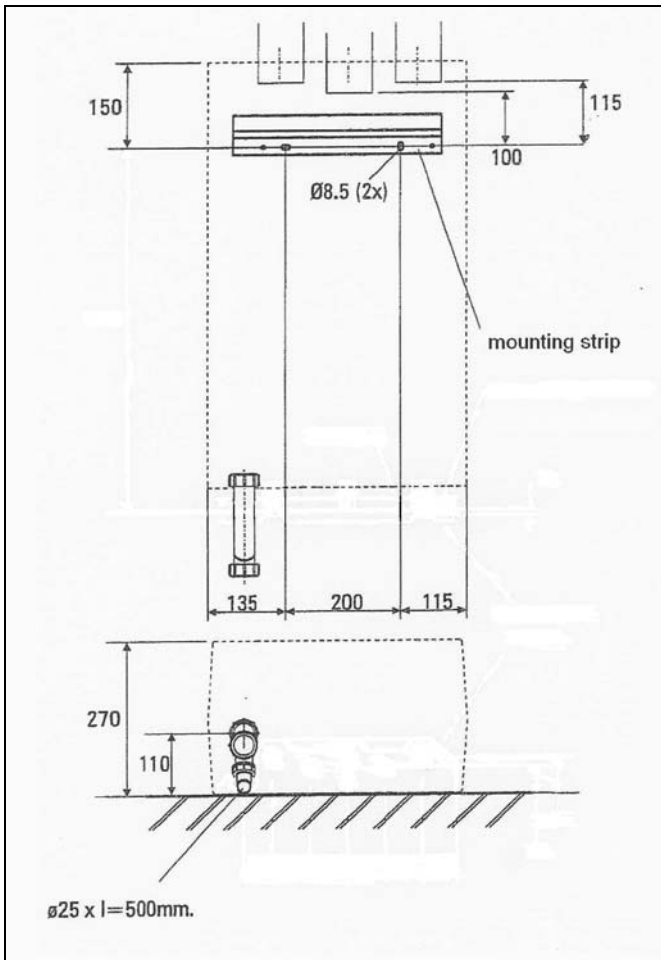

4.4 Boiler location

The appliance can be fitted to a mounting frame. The assembly or just the appliance should be mounted to a wall with sufficient bearing strength. In case of light wall constructions, resonance sounds may occur.

There must be an earthed electrical supply within a distance of 1 m from the appliance.

In order to avoid freezing of the condensate discharge, the appliance should be installed in a frost-free room.

Keep 5 cm free space above the appliance in order to be able to remove the front panel from the casing.

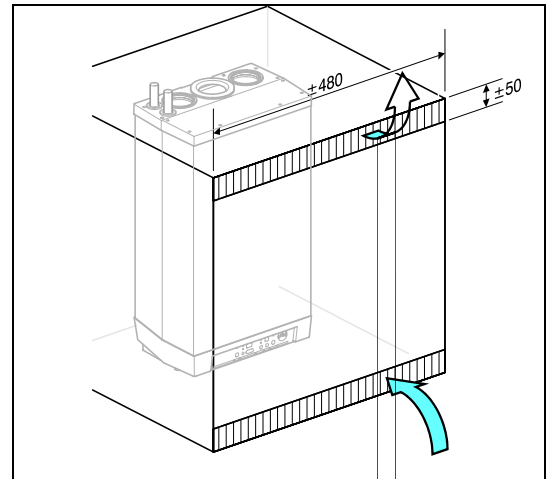

4.4.1 Installation in a kitchen cupboard

Make sure there is sufficient ventilation above and below the appliance. When the appliance is placed in a small cupboard, ventilation openings of at least 50 cm² must be made.

4.4.2 Installation in an airing cupboard

Compartment ventilation is not required for a standard airing cupboard (eg 0.6 x 0.6 x 2.3m high).

4.4.3 Remove front panel

Remove the optional pipework cover and the front panel for carrying out work on the appliance as follows:-

1. Remove the pipework cover (A), if used, forwards.
2. Unscrew both screws (B) at the bottom of the appliance.
3. Lift the front panel (C) and remove it forwards.

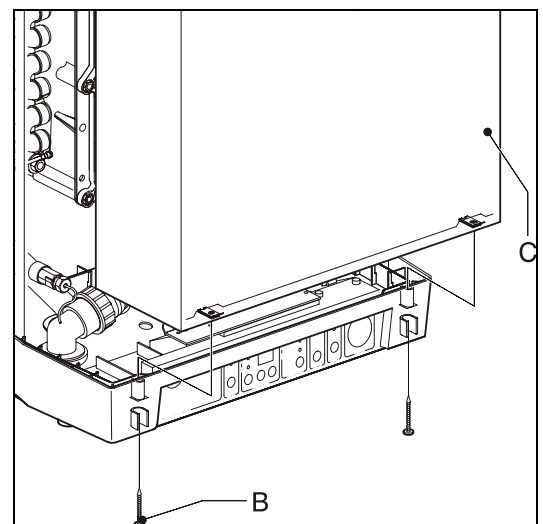
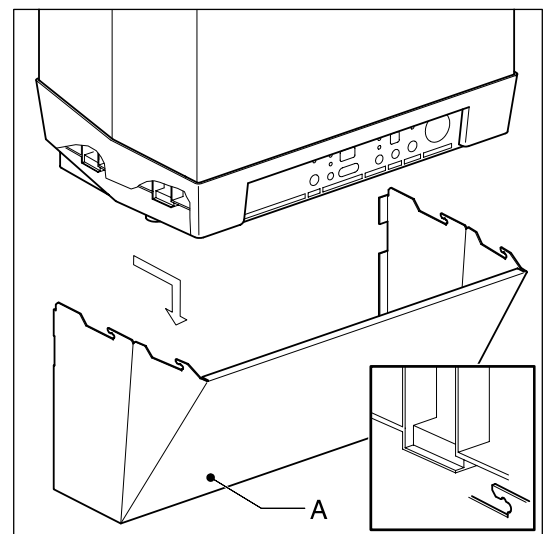

4.5 Mounting

Depending on the mounting option ordered, the following mounting methods are available:-

Mounting strip (A) alone,

OR rear mounting frame (C), which is an *optional* item. This arrangement allows for vertical pipework behind the boiler.

Note that for this appliance, the CH flow and CH return are at the top of the casing.

4.5.1 Fitting the mounting strip

1. Fasten the mounting strip horizontally to the wall, using the screws and plugs supplied.
2. Mount the appliance.
3. Mount the gas valve.
4. Make the top CH flow and CH return connections.

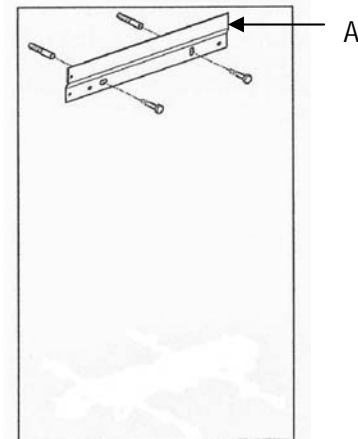

4.5.2 Fitting the rear mounting frame

1. Fasten the frame vertically to the wall, using the screws and plugs supplied.
2. Mount the appliance.
3. Slide the gas pipe into the frame and mount the gas valve.
4. Make the top CH flow and CH return connections.

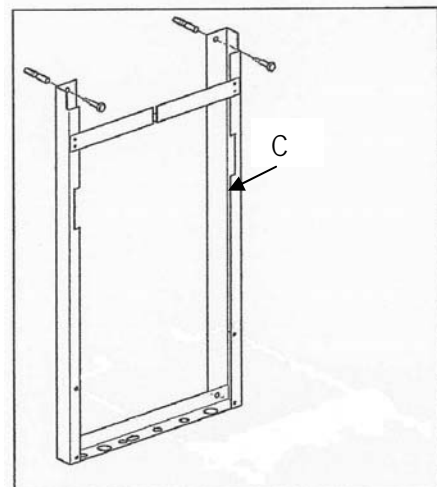

Caution

The appliance is wider than the frame.

4.6 Mount the appliance

1. Place the appliance: slide it top-down over the mounting strip.
2. The flexible tube from the condensate siphon should be inserted into an open waste pipe of not less than 32 mm diameter. If connected to a soil pipe or waste system, the waste pipe must include a trap (similar to arrangement for washing machine).
3. Mount the air supply and the flue discharge.
4. Close the air supply opening that is not used with the plug supplied.

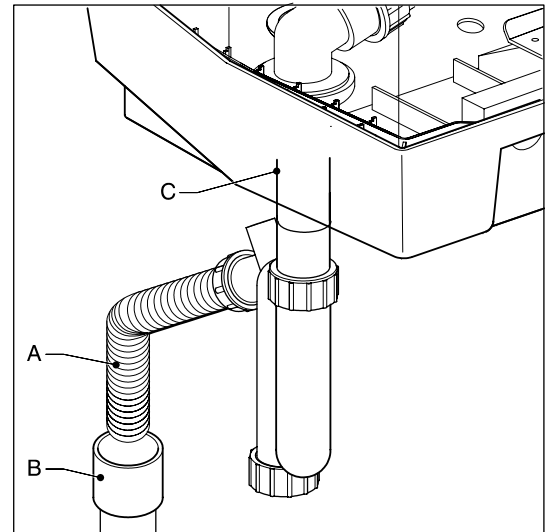

4.7 Fit the pipework cover (optional)

1. Insert the four hooks of the pipework cover in the slots of the appliance.
2. Slide the cover backwards, sliding the hooks into the slots and locking the cover.

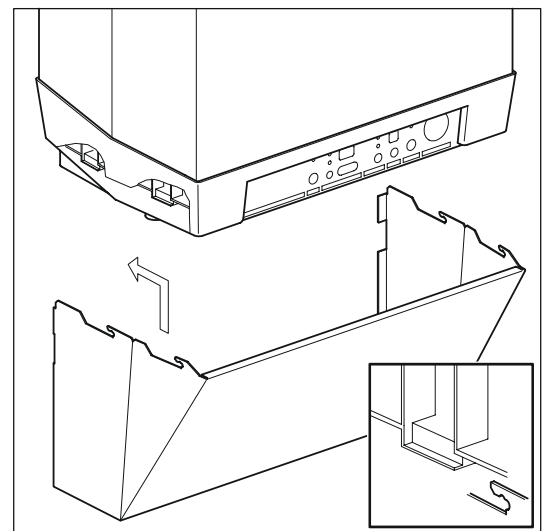

5. CONNECTIONS

5.1 Connect the CH system

1. Flush the CH system thoroughly.
2. Connect the flow and return pipes to the top pipes from the appliance.
All pipes must be mounted tension-free in order to avoid ticking of the pipes.
Existing connections must not be twisted in order to avoid leaks at the connections with the external pipes.

The CH system should be provided with:-

- A drain tap at the lowest point of the system.
- A header tank.

5.1.1 Thermostatic radiator valves

Building regulations require a room thermostat to be fitted on all installations. Do not fit a thermostatic valve on the radiators in the room where the thermostat is situated, otherwise the controls will not function correctly.

5.1.2 System bypass

A bypass is not required for the safe operation of the appliance. It may, however, be required in conjunction with certain controls on a heating system.

5.2 Connecting the gas supply

1. Install a gas filter in the connection of the appliance when the gas can be polluted.
2. Connect the appliance gas valve to the gas pipe.
3. Check the boiler's data plate to ensure that the appliance has been set for the correct gas supply. The boiler is supplied for Natural Gas (G20). A propane (G31) gas conversion set is available and an appropriate sticker is included (see §7.7).
4. The meter governor should deliver a dynamic pressure of 20mbar for natural gas or 37mbar for propane.
5. To prevent the ingress of foreign matter and possible damage to the gas-regulating block, the gas supply pipe must be checked for contaminants prior to connection to the boiler.
6. On final connection of the gas supply to the boiler, the complete gas installation, including the meter, must be tested for gas soundness and purged as described in BS6891.

5.3 Electrical connection



CAUTION

The appliance requires a 230 V ac 50 Hz mains supply, and must be earthed and connected via a double pole isolating switch fitted with a 3 amp fuse. The switch must be readily accessible, within 1m of the appliance, and provide complete electrical isolation for the boiler and control system.

The appliance is supplied factory wired complete with 1 m of mains cable. (Note – the plug must be removed from the cable). All electrical connections to the mains supply must be made in full accordance with the current I.E.E. regulations (BS 7671).

Isolate the supply by opening the double pole switch when carrying out maintenance activities.

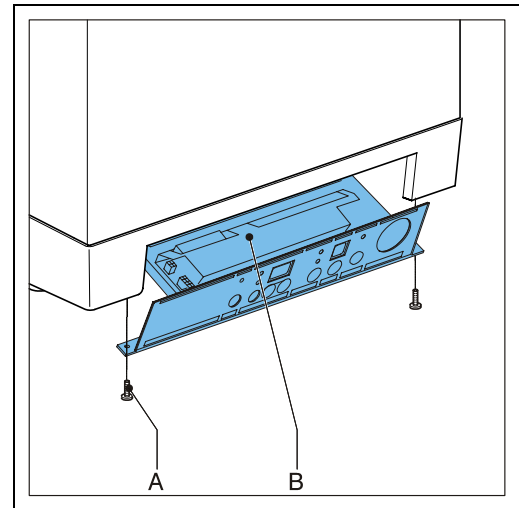

1. Remove the optional pipework cover forwards.
2. Unscrew the screws (A) in order to gain access to the space of the burner controller (B).
3. The cover plate (& display) hinges open downwards. This gives access to the controller and electrical connections.
4. Consult § 5.3 and § 10.1 for making connections.
5. After having made the required connections, connect the appliance to a switched supply, as given above.

Controller Label and Associated Terminals

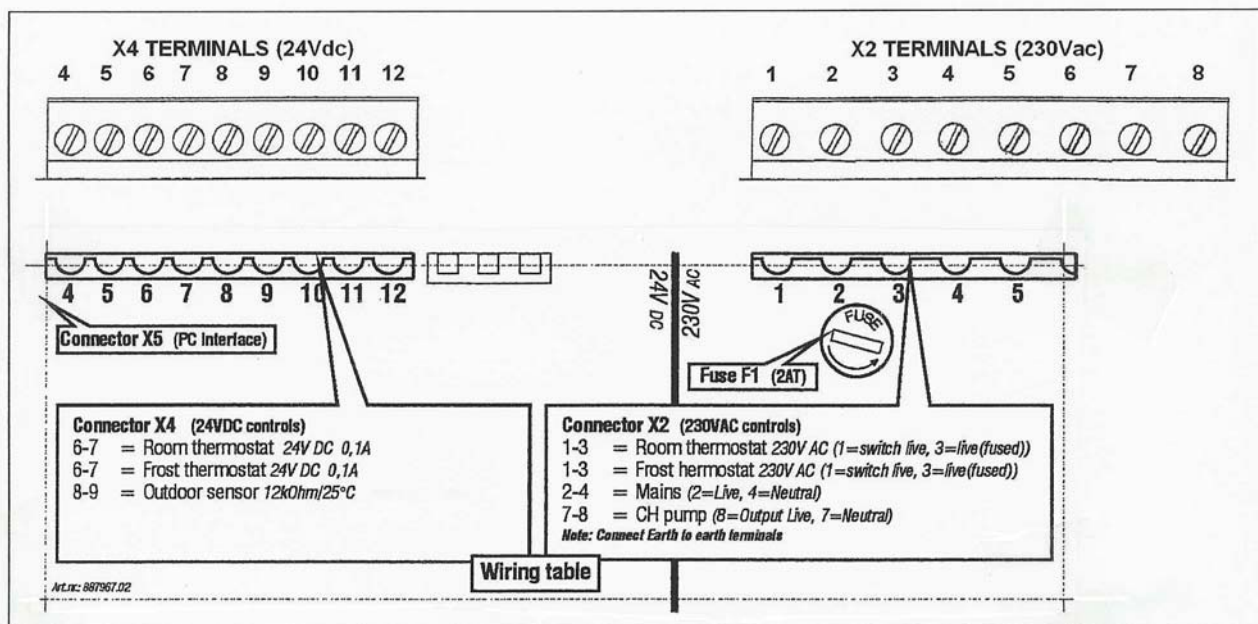

5.3.1 24V dc Electrical connections

24V dc Terminals X4

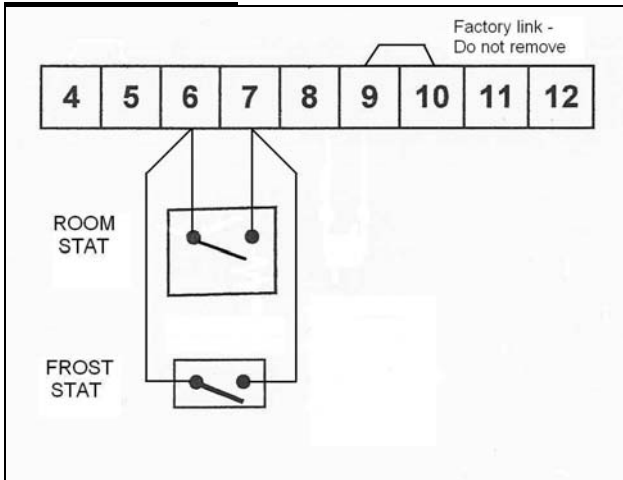

Description	Connector X4	Remarks
Room stat	6 - 7	6= +24Vdc
Outside temp sensor	8 - 9	Not applicable
Frost stat	6 -7	Parallel through room stat
Power 24Vdc (3VA)	6= +24Vdc, 9= -.	

Notes

- Under no circumstances must any electrical power be input to the room thermostat terminals. It is a volt-free switch.
- Care must also be taken to avoid induced voltages caused by the running of the thermostat cables along side mains voltage cables.

5.3.2 Volt free Room thermostat on/off

- Connect the room thermostat. See § 5.3.1.
- The terminal block for the connection for a volt free room thermostat, or time clock, is X4 on the control panel. The terminals are wired to the input circuit of the control unit, which has its own 24V dc 'wetting voltage'.
- If using a room thermostat with heat accelerator, this must be set at 0-1A.
- The maximum permissible resistance of the room thermostat circuit and cable is 15 Ohms.
- Where a 'wireless' room thermostat is employed, consult the manufacturer's instructions for installation.

5.3.3 230Vac Electrical connections

230Vac Terminals X2

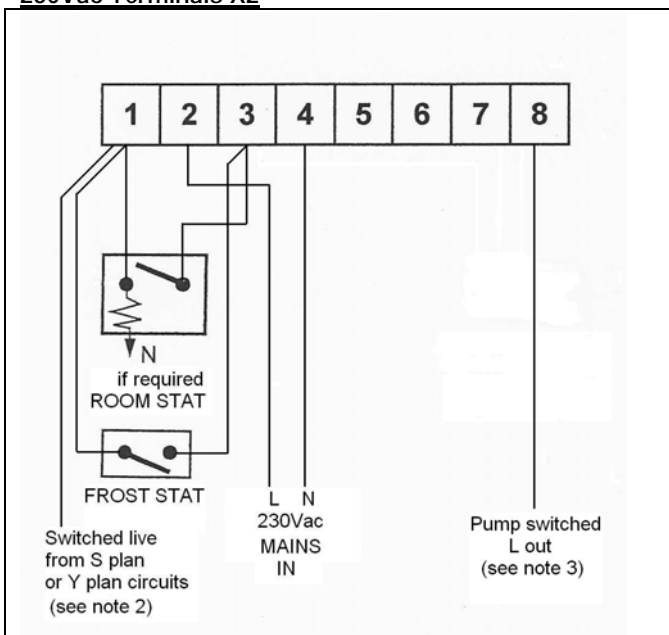

Description	Connector X2	Remarks
Mains In	L= 2, N= 4	Earth:see §10.1
Room stat	1= switch live, 3= live (fused)	
Frost stat	1 - 3	Parallel through room stat
External pump (see note 3)	7 = N, 8 = switched live	

Notes

- The 230Vac stat circuits are alternative to the 24Vdc circuits. If the stat has a neutral connection for heat accelerator, then connect it for more efficient operation.
- The switched live can also be used for S plan or Y plan circuits (note that the 230Vac live to the Wiring Centre must come from the same fused spur as the 230Vac supply to the boiler).
- A switched live output is available for a pump if the heating system requires pump overrun. Note that the appliance itself does not require this feature.

5.4 General Flue Requirements

5.4.1 Flue terminal clearances

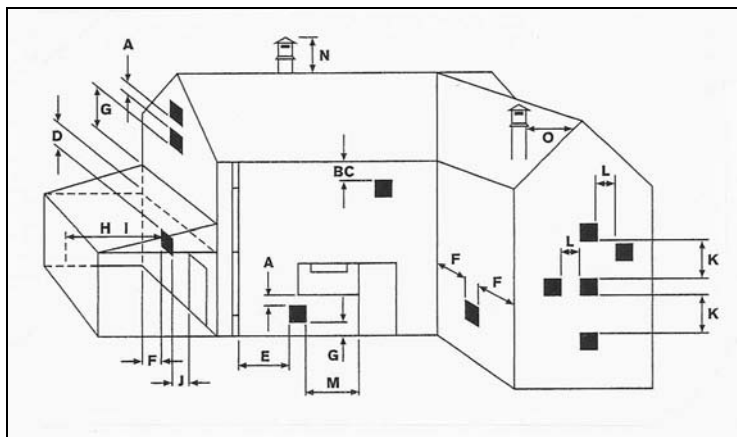

The flue terminal must be sited with minimum clearance distances as shown in the diagram.

A terminal guard must be fitted if the terminal is sited less than 2m above ground level.

Where the flue terminates within 1m of a plastic or painted gutter or within 500mm of painted eaves, then protection should be provided in the form of an aluminium shield at least 1m in length, fitted to the underside of the gutter or painted surface.

Please Note!

Due to the low flue gas temperature, 'pluming' will occur at the flue terminal. Care should be taken to ensure that the discharge plume will not cause annoyance to the customer or neighbours. It is generally recommended that flues should discharge vertically at roof level. In this position, pluming is not normally a problem.

TERMINAL POSITION	MIN DISTANCE
A - Directly below an openable window or other opening, eg air brick	300mm
B - Below gutters, soil pipes or drain pipes	75mm(1)
C - Below eaves	200mm(1)
D - Below balconies or car port roof	200mm(1)
E - From vertical drain pipes and soil pipes	150mm(1)
F - From internal or external corners	300mm(1)
G - Above ground, roof or balcony level	300mm
H - From a surface facing a terminal	600mm
I - From a terminal facing a terminal	1200mm
J - From an opening in a car port (eg door, window) into a dwelling	1200mm
K - Vertically from a terminal on the same wall	1500mm
L - Horizontally from a terminal on the same wall	300mm
M - From door, window or air vent	300mm
N - Minimum protrusion through roof surface	300mm
O - From vertical wall or obstruction	500mm

NOTE (1)

Minimum distance is reduced to 25mm from a terminal guard.

5.4.2 Flue system

The flue system must be installed in accordance with BS5440:1. Horizontal flue pipe runs must always be installed with a minimum slope of 50 mm/metre towards the boiler. This will prevent condensation from gathering in the flue pipe, and will also reduce the chance of icicles forming over horizontal pipe ends in the Winter.

5.5 Flue discharge and air supply

Two different flue systems are available from Atmos for use with this appliance:-

- 80mm twin pipe system which enables separate air intake and flue pipes to be fitted to the appliance.
- 80/125mm concentric system.

Maximum lengths are specified in § 5.6 and must not be exceeded.

Note - A special concentric through the wall flue kit (60/100mm) is available from Atmos – see § 5.5.3.

5.5.1 Twin-pipe connection

1. When using the right-hand air supply, the sealing cap must be moved to the left-hand air supply.
2. Locate the pipes for the air supply and flue discharge in the supply and discharge stubs. The in-built silicone sealing ring provides an airtight connection.

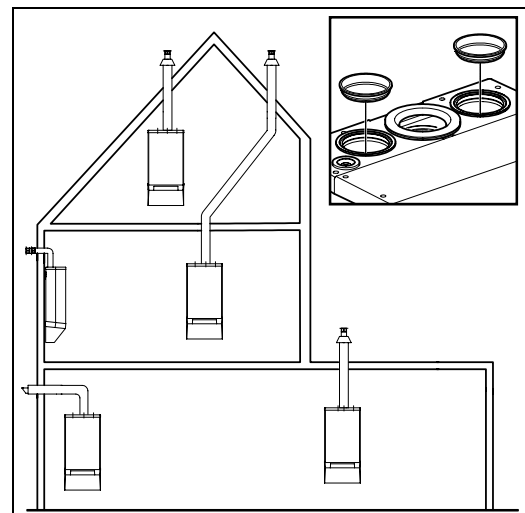
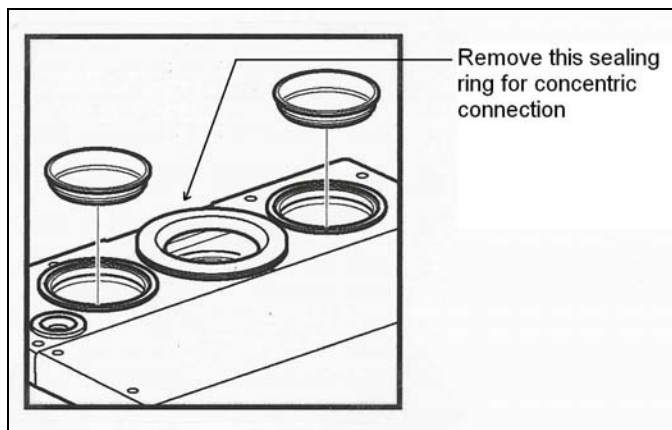
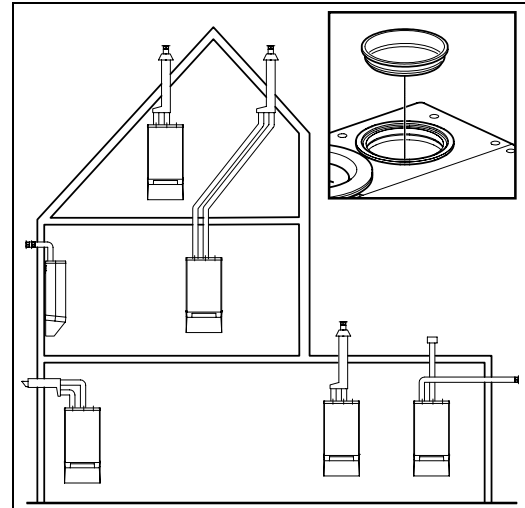

5.5.2 Vertical Concentric connection

IMPORTANT!

Using the concentric adapter set (see photo), the standard two-pipe connection can be changed into a concentric connection.

1. Seal the open air supply connections in the appliance with the sealing cap delivered with the set (item C in photo).
2. Remove the sealing ring around the flue discharge in the appliance, as shown above.
3. In its place, fit the sealing ring $\varnothing 116 \times 110$ mm (item B in photo).
4. Fit the adapter (item A in photo) on the flue discharge.

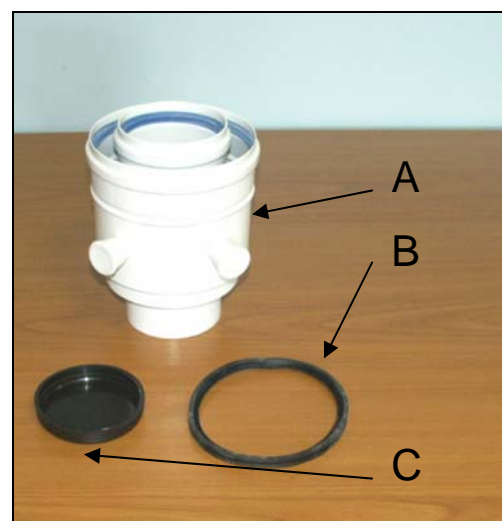

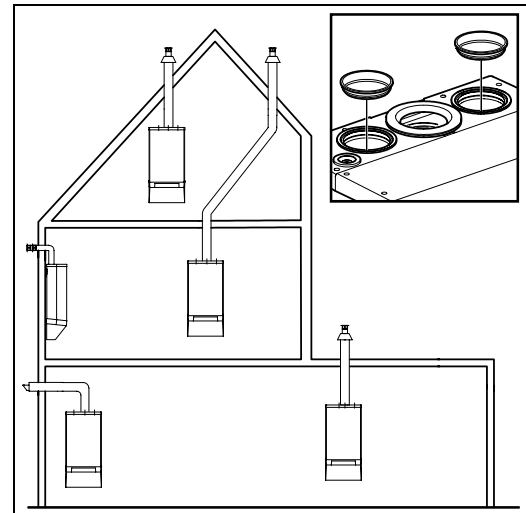
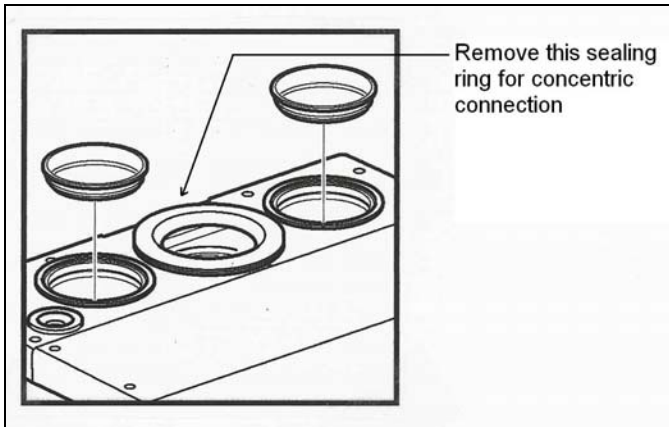

5.5.3 60/100mm Concentric Standard through the wall Horizontal Terminal

IMPORTANT!

Using the concentric adapter set (see photo), the standard two-pipe connection can be changed into a concentric connection.

1. Seal the open air supply connections in the appliance with the sealing cap delivered with the set (item C in photo).
2. Remove the sealing ring around the flue discharge in the appliance, as shown above.
3. In its place, fit the sealing ring $\varnothing 116 \times 110$ mm (item B in photo).
4. Fit the adapter (item A in photo) on the flue discharge.

Note: Check that the adapter A has blue sealing rings fitted (or fit these before use).

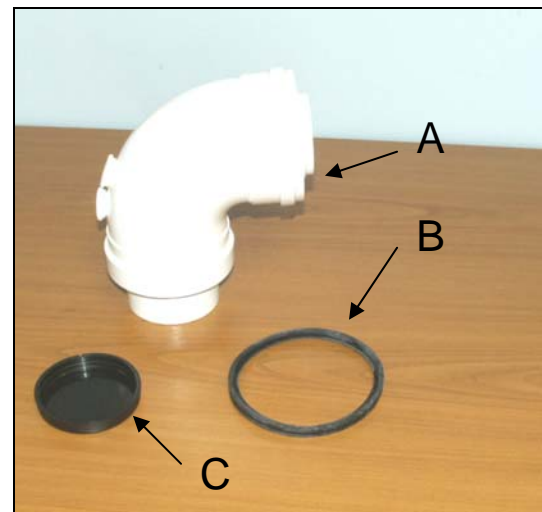

Mounting 60/100mm horizontal concentric terminal

1. Drill hole of diameter 110 mm with 3 deg slope (5 mm rise in 100mm) or larger hole.
2. Chop out shoulder of approx diameter 120 mm for depth of 50 mm.
3. Shorten the terminal to the length required.
4. Fit the spring clip supplied to hold the inner pipe central.
5. Slide the terminal into the opening and fit rosettes to cover the opening.
6. Ensure the pipes slope back to the appliance.

Note

To reduce the shoulder to a minimum, and to simplify the flue installation, use the rear mounting frame, which is 40 mm deep.

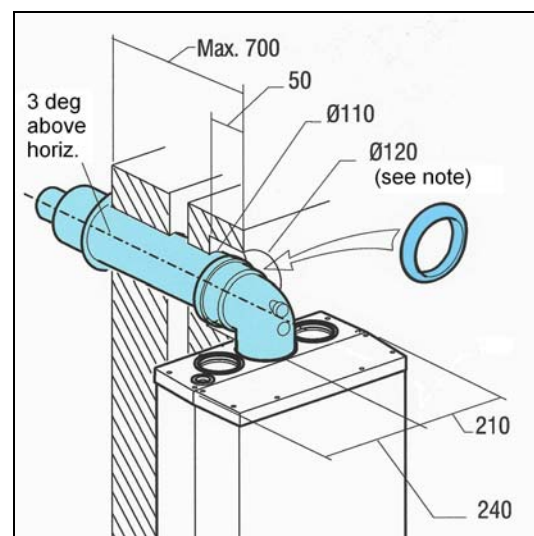

Note: Mark centre of hole on wall at 100mm above the top of the boiler.

5.6 Pipe lengths and details

As the resistance of the flue discharge and air supply pipes increases, the capacity of the appliance will decrease. The maximum allowed power decrease is 5%.

The resistance of the air supply and the flue discharge depends on the length, the diameter and all components of the pipe system. The total allowed pipe lengths of the air supply and the flue discharge are given below:-

Note for twin pipes

The total pipe length is:-

The length of all straight pipe lengths and the lengths of the equivalent pipe lengths of bends.

The maximum length of the air supply and flue discharge 80mm pipes added together is 60 m.

Note for concentric pipes

The total pipe length is:-

The length of all straight pipe lengths and the lengths of the equivalent pipe lengths of bends.

The maximum length of the 80/125mm concentric pipe is 24 m for horizontal pipe and 27 m for vertical pipe.

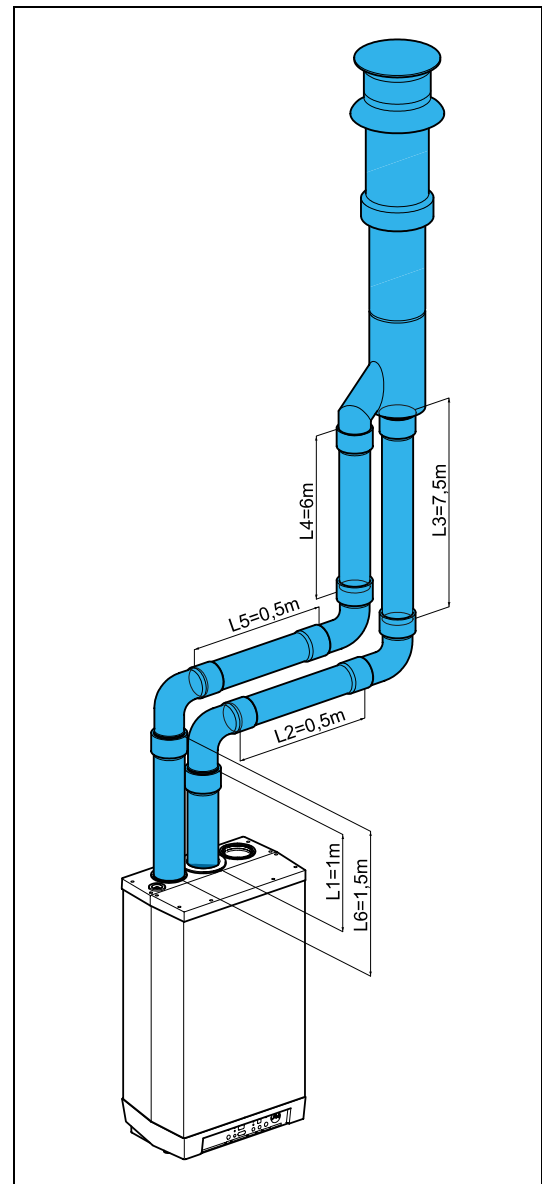
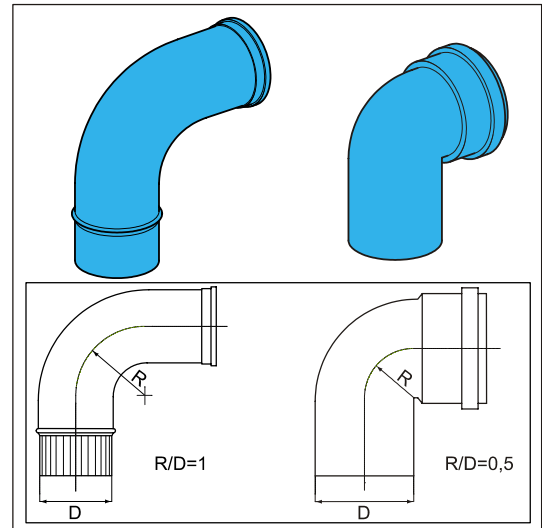

5.6.1 Equivalent lengths

Bend at 90°	R/D=1	2 m
Bend at 45°	R/D=1	1 m
Elbow at 90°	R/D=0.5	4 m
Elbow at 45°	R/D=0.5	2 m

Note – The type supplied by Atmos are Elbows.

For smaller twin pipe diameters, the maximum pipe length is reduced as follows:-

70mm dia: 0.59 x max. pipe length for 80mm dia.

60mm dia: 0.32 x max. pipe length for 80mm dia.

50mm dia: 0.15 x max. pipe length for 80mm dia.

Note that Atmos only supply 80mm twin pipes

5.6.2 Example of 80mm twin pipe calculation

See diagram.

Pipe	Pipe lengths	Total pipe lengths
Flue discharge	L1 + L2 + L3 + 2 x 2 m	13 m
Air supply	L4 + L5 + L6 + 2 x 2 m	12 m
Total length		25m

5.6.3 Example of 80/125mm concentric pipe calculation

With 3 elbows at 90°, the max straight length of concentric pipe that can be used is 24m – 3x4m = 12m.

5.6.4 Pipe, materials and insulation

Pipe	Diameter	Material
Air supply	ø 80 mm	According to the local regulations of fire department and/or power company. Single wall aluminium, galvanized steel plate, stainless steel or plastic. If necessary insulated with 10 mm vapour-tight insulating material or plastic.
Flue discharge	ø 80 mm	Aluminium single wall 1.5mm thick.
Insulation	-	10 mm vapour-tight insulating material when there is a chance of condensation on the outside, caused by a low wall temperature and a high room temperature with a high humidity.

5.6.5 Outlet arrangements

Appliance category	Materials	Supplier
C13	Terminal	Atmos
	Other parts	
C33	Terminal	
	Terminal of Prefabricated chimney	
	Other parts	
C43	All materials	
	At the CLV system	
C53	Inlet grid	
	Other parts and discharge cover	
C63	All materials and terminal	
C83	Inlet grid	
	Main duct	
	Other parts	

5.6.6 Flue discharge pipe and air supply pipe

The mounting below applies to all outlets:-

1. Slide the flue discharge pipe into the discharge stub of the appliance.
2. Slide the flue discharge pipes into each other.
From the appliance all pipes must be slid into the previous one.
3. Mount a non-vertical flue discharge pipe in a slope to the appliance (min. 50 mm/ metre).
4. Mount the folded seams directed upwards in a horizontal part.
5. Tape up non-gastight connections with heat and moisture-resistant aluminium tape.

The mounting below applies to all air supply pipes:-

1. Slide the air supply pipe into the supply stub of the appliance.
2. Tape up non-airtight connections with moisture-resistant tape.
3. Fit insulation, if necessary.

5.7 Outside wall outlet for twin pipe terminal - horizontal

Appliance category: C13



CAUTION

Pipes for connecting the air supply and the flue discharge between the appliance and the terminal must have a diameter of 80 mm.

- A. Atmos twin pipe terminal horizontal. To be extended for a balcony outlet with one or two standard pipes (diameter 80 mm).
- B. Outlet grid.
- C. Wall cover plate (2x).

Maximum pipe length

See §5.6.

Flue discharge pipe and air supply pipe

For mounting, see § 5.6.6.

Mounting twin pipe terminal

1. Make two openings of diameter 90 mm at the place of the outlet.
2. Cut the pipes to the correct length.
3. Slide the supply and discharge pipes into the openings.
4. Cover the openings with wall cover plates.
5. Mount the outlet grids to the supply and discharge pipes.
6. Attach them to the pipes.
7. Ensure the pipes slope back to the appliance.

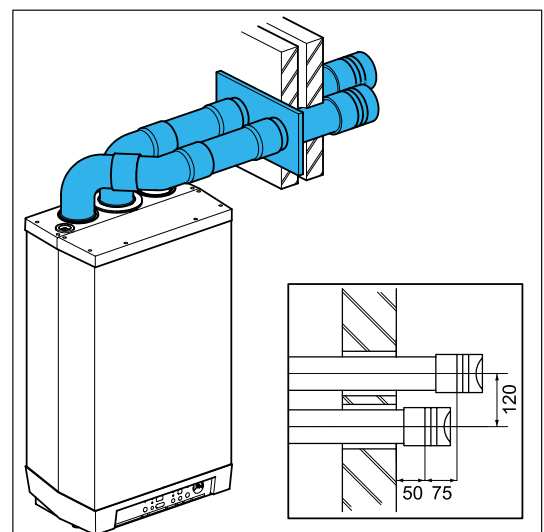
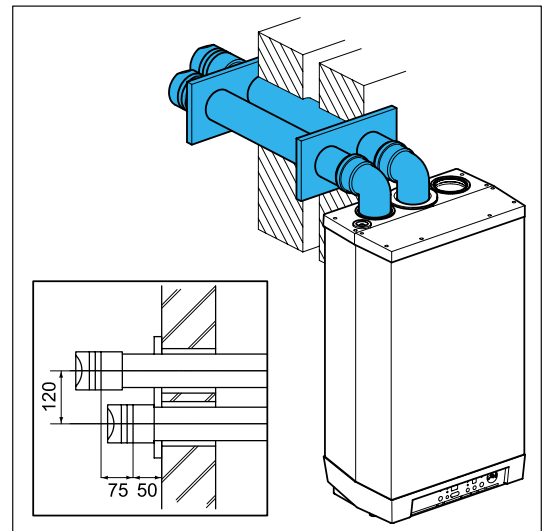
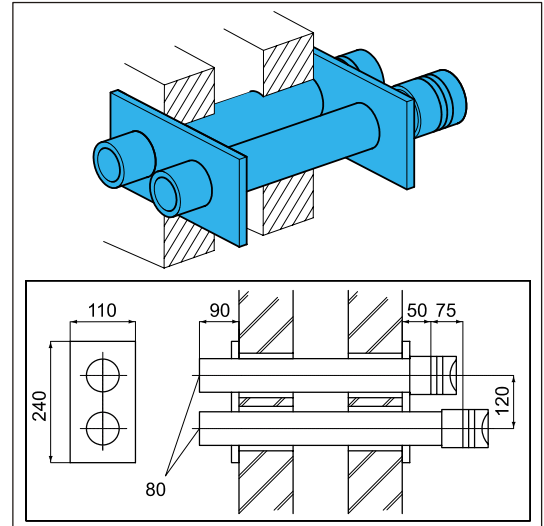

Mounting a twin pipe terminal extension pipe(s) for balcony outlet

When the free outlet is hindered by an eave, balcony, gallery or anything else, the air supply pipe and the flue discharge pipe must be extended to at least the front side of the overhanging part.

When the air supply is not disturbed by obstacles, such as a console or separating wall, and when the outlet is not at the edge of a building, the air supply pipe does not need extension.

1. Extend the flue discharge pipe and, if necessary, also the air supply pipe of the terminal with standard flue discharge and air supply pipes to the correct length required.
2. Slide the flue discharge pipe and, if necessary, also the air supply pipe into the discharge and supply pipes of the terminal.
3. Ensure the pipes slope back to the appliance.
4. Mount the outlet grids to both pipes.

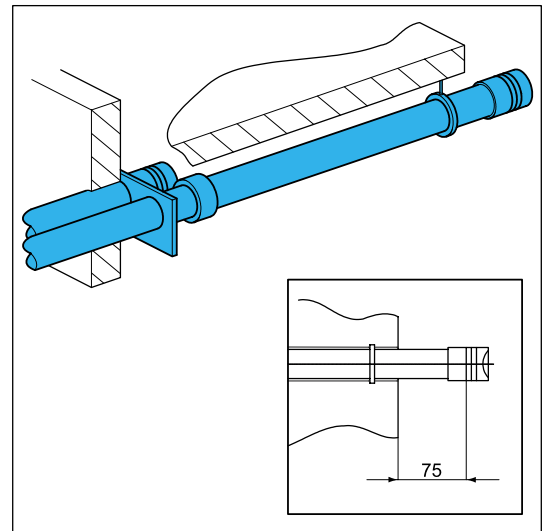
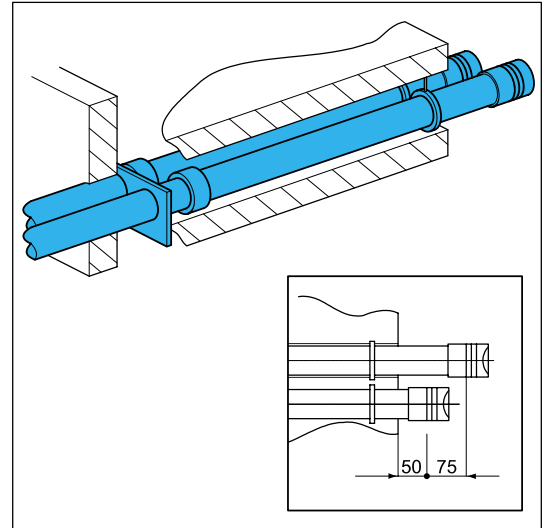

5.8 Outside wall and roof outlet concentric terminal horizontal

Appliance category: C13



CAUTION

Pipes for connecting the air supply and the flue discharge between the appliance and the terminal must have a diameter of 80 mm.

- A. Atmos concentric terminal horizontal.
For outside wall or roof outlet horizontal.
- B. Atmos concentric pipe.
For extension of a balcony/gallery outlet.

Maximum pipe length

See §5.6.

Flue discharge and air supply pipes

For mounting, see § 5.6.6.

Mounting 80/125mm horizontal terminal

1. Make an opening of diameter 130 mm at the place of the outlet.
2. Shorten the terminal to the length required.
3. Mount the outlet grid and attach this to the inside pipe.
4. Slide the terminal into the opening and fit rosettes to cover the opening.
5. Ensure the pipes slope back to the appliance.

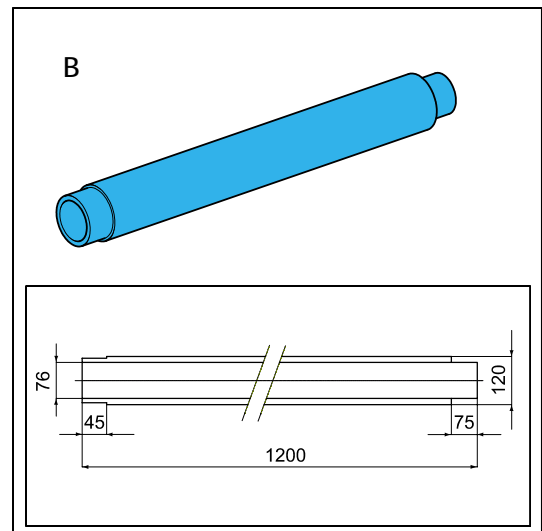

Mounting of combination extension pipe for balcony/gallery outlet

When the free outlet is hindered by an eave, balcony, gallery or anything else, the combination terminal must be extended to at least the front side of the overhanging part.

1. Mount the combination extension pipe to the combination terminal.
2. Shorten the combination terminal or the combination extension pipe to the correct length required.
3. Mount the outlet grid and attach this to the inside pipe.

Mount the combination terminal and combination extension pipe in a slope to the appliance.

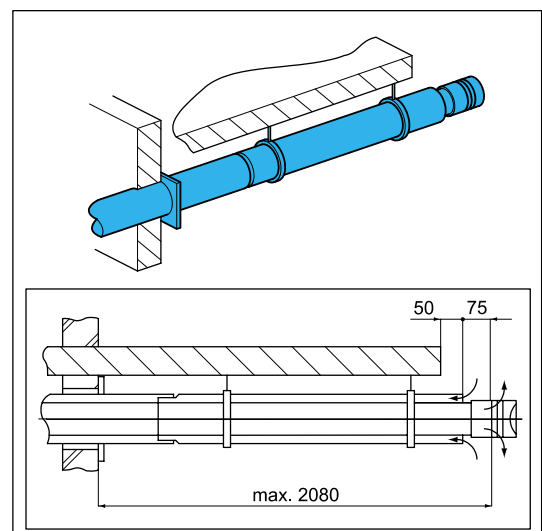

5.9 Roof outlet combination and twin pipe terminal - vertical.

Appliance category: C33



CAUTION

When the Atmos combination terminal - vertical cannot be applied, the air supply and the flue discharge must be separated.

Atmos combination terminal - vertical.

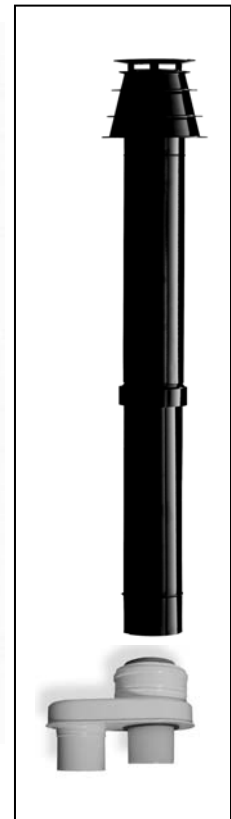
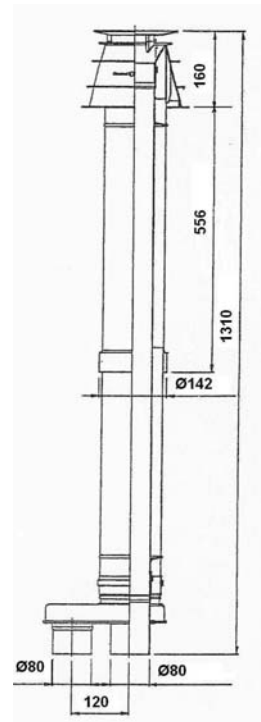

Maximum pipe length

See §5.6.

Flue discharge pipe and air supply pipe

For mounting, see § 5.6.6.

Mounting of combination terminal - vertical

1. Mount a vertical terminal roof pile with lead flashing at the place of the outlet on a pitched roof.
On a flat roof an adhesive plate for a pipe of diameter 126 mm must be applied.
2. Dismount the manifold of the combination terminal (C).
3. Slide the combination terminal (C) from the outside to the inside.
With a pitched roof through the vertical terminal tile with shell.
With a flat roof through the adhesive plate.
4. Mount the manifold of the combination terminal (C) and lock it with a sheet-metal screw or pop rivet.

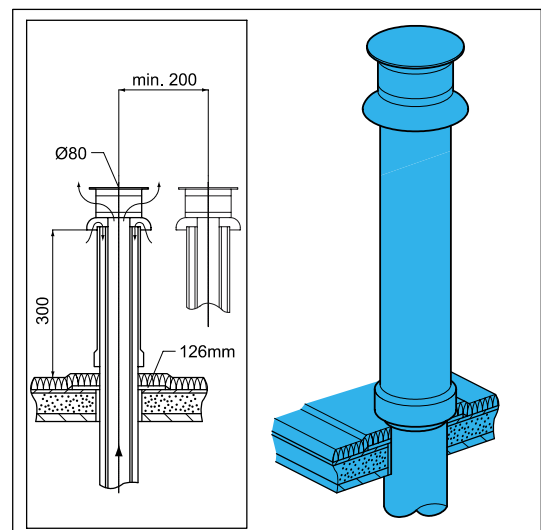
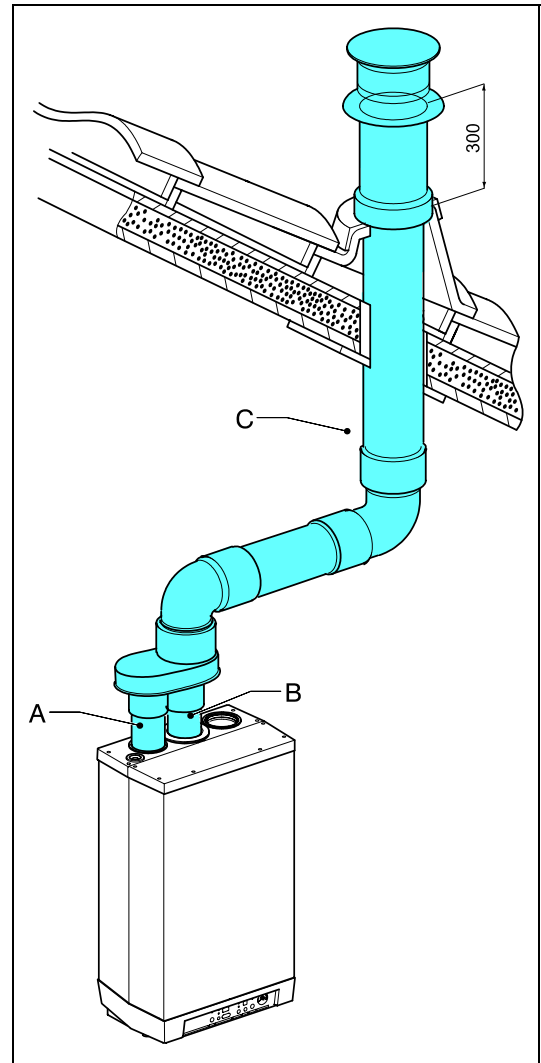

Mounting of twin pipe terminal - vertical



CAUTION

The outlets of the flue discharge and air supply should be placed in the same pressure area.

The air supply from the pitched roof area and the flue discharge by means of a constructional chimney is also possible, but not the other way around.

1. Mount a double-walled flue terminal (diameter 80 mm) with Giveg discharge cover on a pitched roof at the place of the outlet.
2. Mount a ventilating passage (diameter 80 mm) with cross-cut in the corresponding roof passage tile for the air supply.
3. Mount for the flue discharge a double-walled flue terminal (diameter 80 mm) with Giveg discharge cover at the place of the outlet. Mount with a flat roof or a constructional chimney and for the air supply a ventilating passage (diameter 80 mm) with cross-cut in the corresponding adhesive plate.

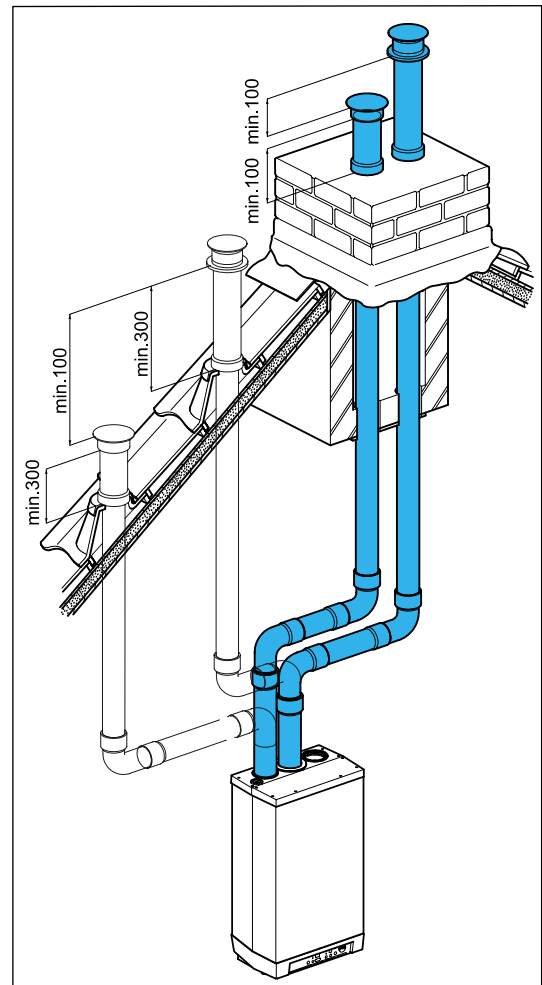

CAUTION

Two outlets must be at a distance of at least 200 mm from each other.

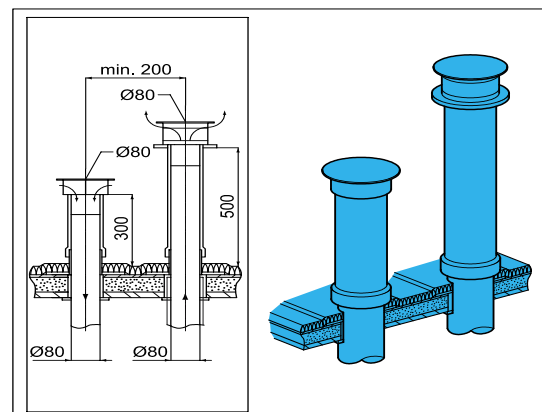

5.10 Roof outlet prefabricated chimney

Appliance category: C33

When there is little space in a shaft, a roof outlet through a prefabricated chimney may be necessary.

The prefabricated chimney must comply with the minimum lengths shown. The supplier must guarantee the proper operation of the prefabricated chimney with respect to wind attack, ice formation, rain ingress, etc.

In view of the different models and requirements, the prefabricated chimneys must be adjusted to the local situation: a gas certificate is not required.



CAUTION

The connection of the air supply and the flue discharge between the appliance and the prefab chimney must be made in pipes of diameter 80 mm.

Maximum pipe length

See §5.6.

Flue discharge and air supply pipes

For mounting, see § 5.6.6.

Mounting of prefabricated chimney

The outlet can be made at any place in the pitched or flat roof surface.

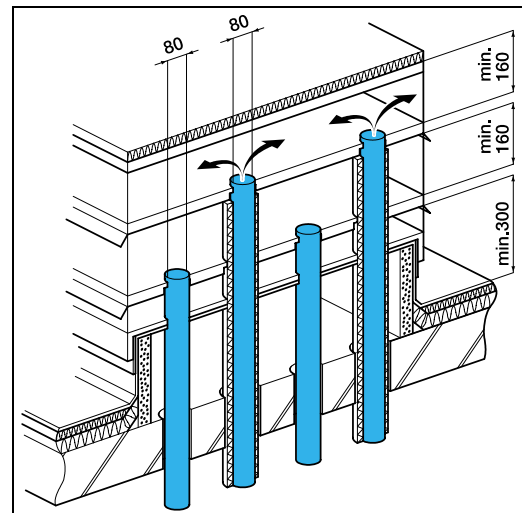
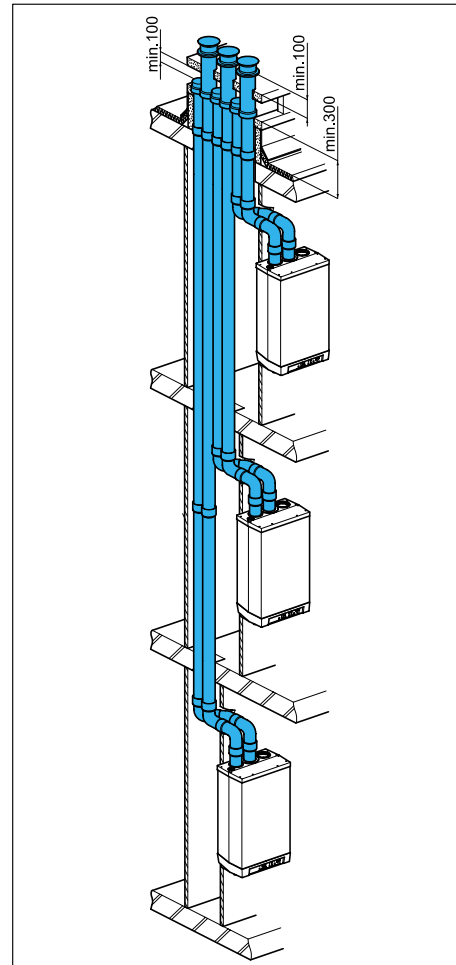

5.11 Roof outlet and air supply from the outside wall

Appliance category: C53



CAUTION

The air supply (A) in the outside wall must be provided with an Atmos inlet grid.

- A. Flue discharge (B) through a prefabricated chimney or through a double-walled roof passage diameter 80 mm with Giveg discharge cover.

Maximum pipe length

See §5.6.

Flue discharge pipe and air supply pipe

For mounting, see § 5.6.6.

Mounting of air supply - horizontal

The air supply (A) can be made at any place in the outside wall.

1. Make an opening of diameter 90 mm at the place of the supply.
2. Shorten the air supply pipe to the correct length out of the wall.
3. Mount the Atmos inlet grid and attach this to the pipe.
4. Slide the air supply pipe into the opening and cover the opening with a rosette, if necessary.
5. Mount the air supply at the place of the outside wall terminal in a slope to the outside, to prevent rain from entering.

Mounting flue terminal - vertical

1. Mount a roof tile with shell in a pitched roof surface at the place of the outlet.
Mount an adhesive plate suitable for a double-walled flue terminal diameter 80 mm (outside diameter 96 mm) in a flat roof.
2. Slide the double-walled flue terminal from the outside to the inside through the roof terminal.
The outlet must protrude at least 500 mm above the roof surface.

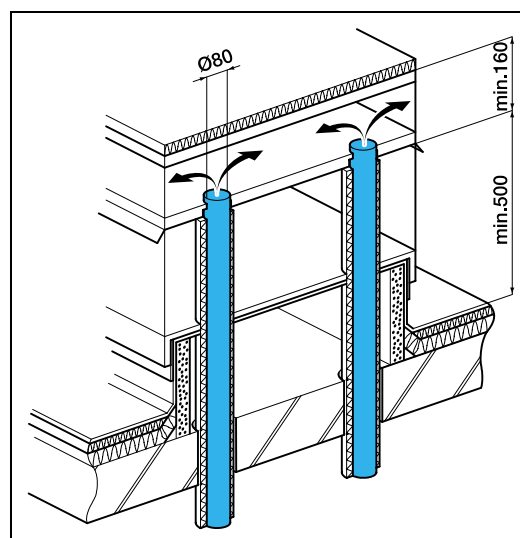
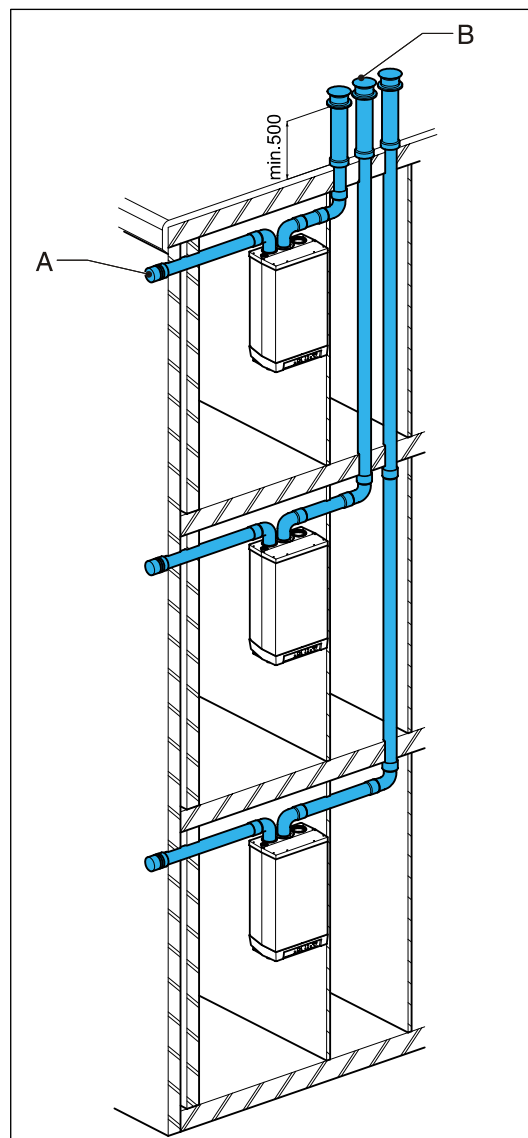

5.12 Air supply from the outside wall and a roof outlet with common discharge system

Appliance category: C83

An air supply from the outside wall and a roof outlet with common discharge system is allowed.



CAUTION

The air supply (A) in the outside wall must be provided with an Atmos inlet grid.

The flue discharge (B) must be provided with a pulling discharge cover.

The minimum bore of the common discharge system

Number of appliances	Diameter for InterOpen
	HE 22
2	130
3	150
4	180
5	200
6	220
7	230
8	250
9	270
10	280
11	290
12	300

Maximum pipe length

The maximum length of the air supply and flue discharge pipes between appliance and common flue discharge and air supply together is 75 metres.

Flue discharge pipe and air supply pipe

For mounting, see § 5.6.6.

Common flue discharge

The outlet of the flue discharge can be made at any place in the pitching roof surface, provided that the outlet in the roof surface has the same orientation as the air supply in the outside wall. With a flat roof the outlet of the flue discharge must be made in the 'free' outlet area.

Apply a condensate discharge.



CAUTION

The common discharge system must be provided with a pulling discharge cover.

When the common discharge system is located in the outside air, the discharge pipe must be double-walled or insulated.

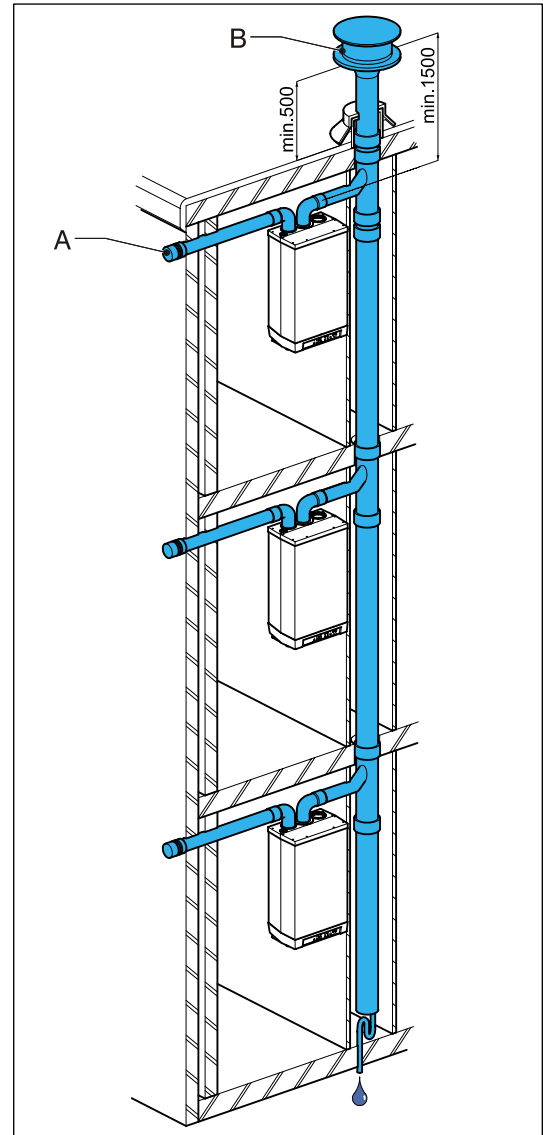

Remark

The common discharge system has been inspected in combination with the appliance.

5.13 Roof outlet CLV system

Appliance category: C43



CAUTION

A roof outlet through a Combination Air supply-Flue discharge system (CLV system) is allowed.

For the common flue discharge cover and air supply cover a certificate of incorporation from the Gastec-Gasinstituut is required.

The common air supply and the common flue discharge may be made concentrically(B) or separately(A).

Maximum pipe length

The maximum length of the air supply and flue discharge pipes between appliance and CLV system together is 75 metres.

Flue discharge pipe and air supply pipe

For mounting, see § 5.6.6.

Remark

The passage of the common supply and discharge system should be given by the manufacturer of the CLV system.

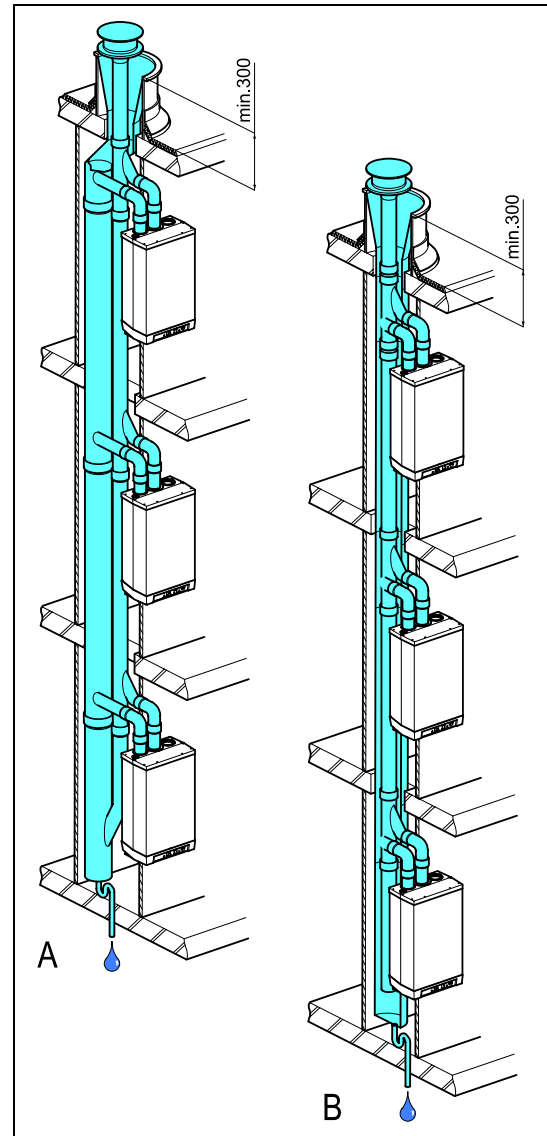

6. COMMISSIONING

6.1 Fill and de-aerate the appliance and the system



WARNING

Connect the appliance to the mains voltage only after filling and de-aerating!

6.1.1 CH system



WARNING

When an additive is added to the CH water, this should be suitable for the materials used in the appliance, such as copper, brass, stainless steel, steel, plastic and rubber.

1. Fill the header tank and system.
2. De-aerate the system with the manual air vents on the radiators.
3. Check all joints for leaks.
4. **Fill the siphon with water (important).**

6.1.2 Gas supply

1. De-aerate the gas pipe with the inlet pressure measuring nipple on the gas valve.
2. Check the connections for leaks.
3. Check the inlet pressure and the burner pressure. See Gas and air control.

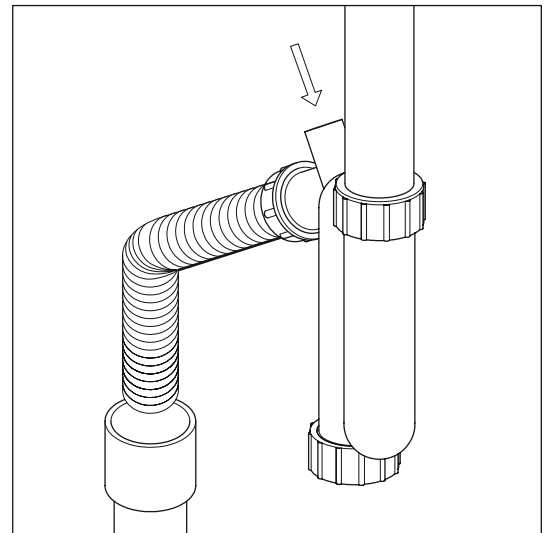

6.2 Commissioning of the appliance/ system

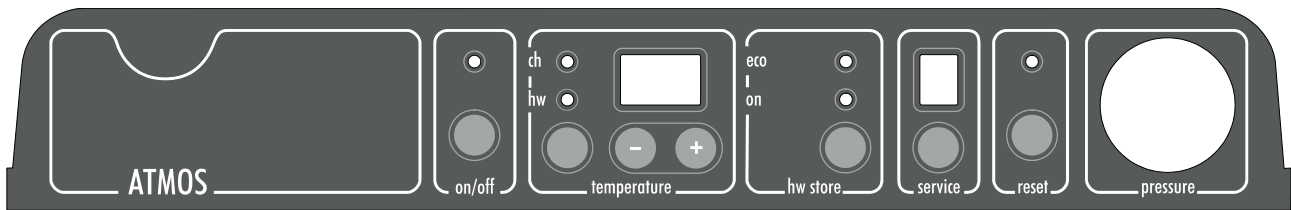

After having carried out the above operations, the appliance/ system can be commissioned.

1. Switch on the electrical supply to the appliance.
The appliance will carry out a self-test: **[2]** (on service display).
After completing the self-test, the appliance goes to standby: **[1]** (on service display).
2. Press the on/off button in order to put the appliance into operation.
The boiler is heated and on the service display appear **[3]**, **[4]**, **[7]**.
3. Set the pump position on the basis of the set maximum power and the resistance of the system on the water side. For typical graph showing the head of the pump and the pressure loss of the appliance, see §7.5.
4. Set the room thermostat higher than the room temperature. The appliance will switch to CH operation: **[5]** on service display.
5. Heat the system and the appliance to about 80°C.
6. Check the temperature difference between the supply and return of the appliance and the radiators. This should be about 20°C. At this stage set the maximum power on the service panel. See Setting of maximum power. If necessary, change the pump position and/or the radiator valves. The minimum flow-through is:-
 - 200 l/h at a set power of 7.0 kW
 - 750 l/h at a set power of 26.2 kW
7. Switch off the electrical supply to the appliance.
8. Check the heating system for proper operation.
9. Instruct the User about the operation of the heating system.

Note

The controls on the display for 'hw' and 'pressure' are not applicable for the HE22 appliance.

Note

The pump is not part of the HE22 appliance.

Remarks

- The appliance has been provided with an electronic burner controller that ignites the flame and continuously monitors this at each heat demand from the heating system.
- Step modulation is set on (factory setting) so that the power/speed is increased gradually. This provides the best CH operation. However if the appliance is being used for heating an indirect hot water tank, the step modulation can be set off. The appliance will then start almost immediately at the maximum setting and the system will heat up faster.

6.3 System Shutdown



CAUTION

Drain the appliance and the system when the mains voltage has been disconnected and there is a chance of freezing.

1. Drain the appliance using the drain tap.
2. Drain the system at the lowest point.

6.3.1 Frost protection

- In order to avoid freezing of the condensate discharge pipe, the appliance should be installed in a frost-free room.
- In order to avoid freezing of the appliance (heat exchanger), it has an appliance frost protection. When the temperature of the heat exchanger drops to 5°C, the burner will be activated and the pump will start running until the temperature of the heat exchanger reaches 10°C.
- When the system (or a part thereof) can freeze, a frost thermostat should be installed in the area to be protected. Connect this according to the wiring diagram. See § 10.1.

Note!

The external frost thermostat is not active when the appliance has been switched off at the operating panel or when the mains voltage has been interrupted.

7. SETTING AND ADJUSTMENT

The functioning of the appliance is mainly determined by the (parameter) setting in the burner controller. A part of this can be set directly via the operating panel, while another part requires an Installer code to be entered before settings can be changed.

7.1 Directly via operating panel

The following settings can be made directly via the operating panel.

Appliance on/off

The appliance is activated by means of the *On/Off* key.

When the appliance is working, the green LED will be lit. When the appliance is off, one bar on the service display () is lit to indicate the presence of voltage.

The maximum CH supply temperature

During CH operation (the LED CH is lit), the CH supply temperature can be changed using the "+" and "-" keys. When the appliance is not working, a selection can be made using the 'temperature' button. Use this button to select 'ch' and set the temperature. Confirm the setting by pressing the *Reset* key.





Reset button

When a locking fault is indicated by means of a flashing figure on the service display, the appliance can be restarted by pressing the *Reset* key for 5 seconds. Check the nature of the fault by means of the fault codes under §8 and solve the problem, if possible, before resetting the appliance.

7.2 Settings through the service code

The burner controller of the appliance has been set in the factory according to the parameters of § 7.3.

These parameters can only be changed with the service code. Proceed as follows to activate the program memory:

1. Set the appliance in the off mode using the *On/Off* key ( on the service display).
2. Simultaneously press the *Service* and *Reset* keys, until a  appears on the service and the temperature displays.
3. Using the "+" and "-" keys, set  (service code) on the temperature display.
4. Press the "*Service*" key to confirm the code.
5. Set using the "*Service*" key the parameter to be set on the service display.
6. Set using the "+" and "-" keys the parameter to the required value on the temperature display.
7. After having entered all required changes, press the "*Reset*" key until  appears on the service display.
8. Switch on the appliance again using the "*On/Off*" key.

The burner controller has now been reprogrammed.

By pressing the selection key "*ch/hw*" (left hand key of "temperature" keys), the factory settings of the parameters are restored.

Remark - This can only be done if the service code has been set.

7.3 Parameters

Parameter	Setting	Factory setting	Description
		InterOpen HE 22	
0	Service code [15]	-	Access to installer settings. The service code must be entered (=15).
1	System type	1	0 = standard 1 = heating only operation + indirect hot water tank (Note: Factory setting is 1. Do not change this setting) 2 = n/a 3 = n/a 4 = n/a 5 = n/a
2	CH pump continuous	0	0 = pump overrun only 1 = pump continuously active 2 = CH pump continuously active with external MIT switch
3	Set CH power	50	Setting maximum CH load in percentage
4	Set max power	65	Percentage max power (can be increased up to 99)
5	n/a		
6	n/a		
7	n/a		
8	CH pump overrun time after CH operation	1	Setting range 0 - 15 minutes Note: Pump overrun is only available if the pump output X2/8 is used for the external pump.
9	CH pump overrun time after external hot water tank operation	2	Setting range 0 - 15 minutes (n/a)
A	Position three-way or two-way valve	0	0 = confirmed during CH operation (n/a) 1 = confirmed during hw operation (n/a)
b	n/a		
C	Steps modulation	1	0 = step modulation off during CH operation 1 = step modulation on during CH operation
d	Minimum speed/ output	30	Setting range 25 to 40% 40 = propane
E	Min. supply temperature during OT demand (OT = OpenTherm thermostat)	10	Setting range 10°C to 60°C. If the OT thermostat demands a supply temperature that is below this set value, the heat demand cannot be met. (n/a)
F	Starting speed	70	Setting range 50 to 99%
H	Max. fan speed	45	Setting range 40 to 50 (40 = 4000 rpm, 50 = 5000 rpm) The absolute maximum speed can be set through this parameter.
n	n/a		
o	n/a		
P	Minimum switch off time during CH operation	5	Setting range 0 to 10 minutes (anti cycling function)

7.4 Setting maximum CH power

The maximum CH power is set to 50% in the factory. When the CH system requires more or less power, the maximum CH power can be changed by adjusting the fan speed. See table: Setting CH power.

This table gives the relation between the fan speed and the appliance power.

Setting CH power

Required CH power (approx kW)	Setting on service display (% of the maximum speed)
22.6	83
20.5	75
19.1	70
17.8	65
16.4	60
15.0	55
13.7	50
12.4	45
11.0	40
9.6	35
8.2	30
6.9	25

Caution

The power slowly increases while burning (modulation by time) and decreases as soon as the set supply temperature is reached.

7.5 Setting pump power

To transport the heat from the appliance into the CH system, a minimum water flow is required (see table below).

- Set the pump position on the basis of the set maximum power and the resistance of the system on the water side. See typical diagram: Pressure loss and pump lift, type Ups 50-130, positions 1, 2 and 3.
- Check the temperature difference between the supply and return of the appliance: this should be about 20°C.

The minimum flow-through	Set power
200 l/h	7.0 kW
750 l/h	26.2 kW

- A. InterOpen HE22
- B. (Not applicable)
- I. Pump position 1
- II. Pump position 2
- III. Pump position 3
- X. Flow-through in litres/hr
- Y. Pressure loss / pump lift in metres head

Note
The pump is not part of the HE22 appliance.

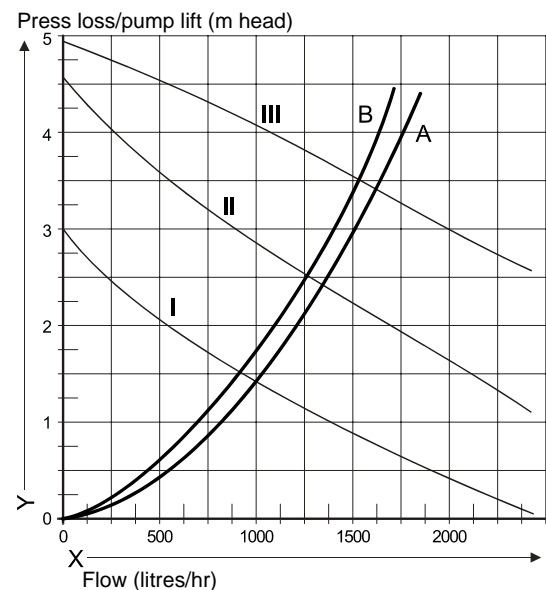

7.6 Conversion to other gas type



CAUTION

Activities on the gas-containing parts should only be executed by a qualified registered installer.

When the appliance is connected to another gas type than the type for which the manufacturer has set the appliance, the gas setting ring must be replaced. Conversion sets for other gas types can be ordered.

Conversion of the gas setting ring

1. Switch off the electrical supply to the appliance .
2. Close the gas tap.
3. Remove the front cover of the appliance.
4. Disconnect the coupling (1) above the gas valve and turn the gas mixing pipe (2) backwards.
5. Replace the O-ring (3) and the gas setting ring (4) by the rings of the conversion set.
6. Reassemble in reverse order.
7. Open the gas tap.
8. Check the gas connections for tightness/ leaks.
9. Switch on the electrical supply to the appliance.
10. Change the parameters d and F to the values given in the table.
11. Now check the setting of the gas/air ratio. (See below)
12. Attach a sticker of the set gas type over the existing sticker on the gas mixing pipe (2).
13. Apply a sticker of the set gas type at the appliance plate.
14. Remount the front cover of the appliance.

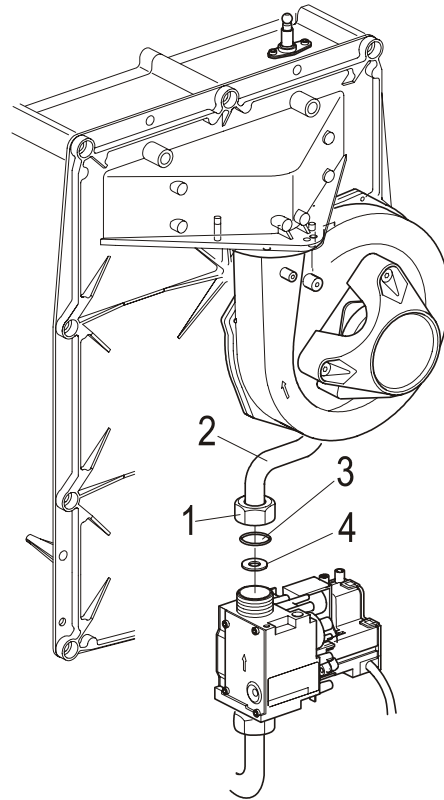

7.7 Gas-air control

The gas-air control is set in the factory and normally does not need any adjustment.

The setting can be checked by measuring the CO₂ percentage in the flues or by measuring the pressure difference.

In case of any alterations, replacement of the gas valve or conversion to another gas type, the control must be checked and reset if necessary according to the table below:-

Gas type	Natural gas H	Propane P
Gas category	2E/H G20	3P G31 (propane)
CO ₂ % at low position (L) (service and -)	8.8 – 9.0	9.8 – 10.0
CO ₂ % at high position (H) (service and +)	9.0 – 9.3	10.0 – 10.7
Gas inlet pressure dynamic (mBar)	17 - 25	25 - 45
Gas inlet pressure static (mBar)	20	37
Gas setting ring diameter (mm)	7.05	5.35
Minimum speed (% of max) (parameter d)	30	40
Min. starting speed (% of max) (parameter F)	70	50



7.8 Setting gas-air control

Setting by measuring the CO₂ content of the flue gases

Remark

- A CO₂ measuring nipple must be mounted right above the appliance in the flue discharge.

- A. Cover screw
- B. Setting screw for the low position (socket head wrench 4 mm)
- C. Off-set pressure measuring nipple
- D. Inlet pressure measuring nipple

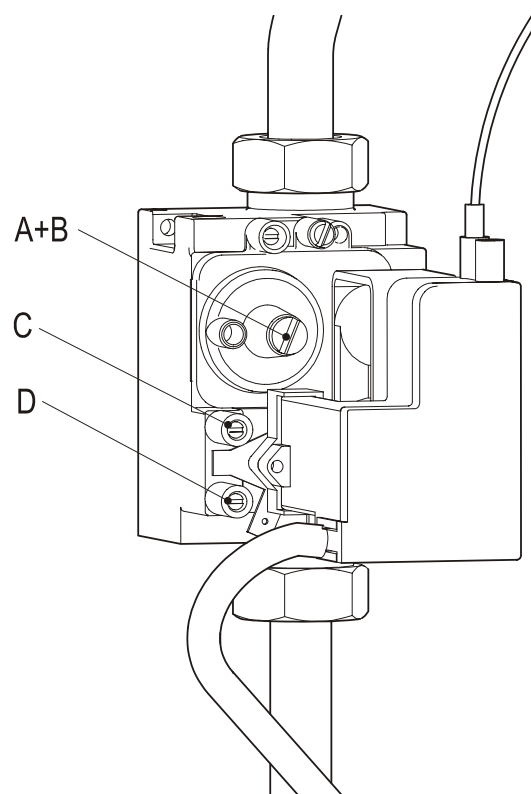

1. Switch off the appliance using the *On/Off* key ( on service display).
2. Open the flue gas measuring nipple and connect the measuring hose.
3. Switch on the appliance using the *On/Off* key.
4. Set the boiler to the lowest output by simultaneously pressing the "Service" and "-" keys on the operating panel until an  appears on the service display.
5. Measure the CO₂ value. If the CO₂ value does not correspond with the value in the table, proceed as follows for setting:-
6. Remove the front cover of the appliance.
7. Remove the cover cap (A) with a flat screwdriver.
8. Using a socket head wrench (4 mm), adjust the setting screw (B) to the correct CO₂ value (clockwise higher and counterclockwise lower).
9. After measuring and setting, set the boiler to the highest output by simultaneously pressing the "Service" and "+" keys (twice) on the operating panel until an  appears on the service display.
10. Measure the CO₂ value. Check that the CO₂ value corresponds with the value in the table. To exit the test mode, press simultaneously the "+" and "-" keys on the operating panel.
11. Replace the cover cap (A) and close the flue gas measuring nipple.
12. Remount the front cover of the appliance.



Caution: Check the measuring nipples used for gas tightness.

Setting the gas valve by pressure measurement

This method is less accurate, but usually gives a sufficient result.

1. Switch off the appliance using the *On/Off* key ( on service display).
2. Remove the front cover of the appliance.
3. Turn the measuring nipple (C) on the gas valve open with two turns and connect this through a tube to the plus connection of the pressure gauge.
4. Switch on the appliance using the *On/Off* key.
5. Set the boiler to the lowest output by simultaneously pressing the "Service" and "-" keys on the operating panel until an  appears on the service display.
6. Read the pressure. This should be about -5 Pa or 0.05 mBar (min. -10 Pa, max. 0 Pa. or min.-0,1 mBar, max. 0 mBar). When this is not the case, proceed as follows for setting:-
7. Remove the cover cap (A) with a flat screwdriver.
8. Set the pressure using setting screw (B) (clockwise higher and counterclockwise lower).
9. After measuring and setting, replace the cover cap A and close the measuring nipple (C) again.
10. Remount the front cover of the appliance.

Caution

Check the measuring nipples used for gas tightness.

8. FAULTS

When the service display or the operating panel is flashing, the burner controller has detected a fault. In case of several faults, the temperature display shows an additional code.

After the fault has been remedied, the burner controller can be restarted by pressing the *Reset* button on the operating panel.

The following faults are detected and displayed:-

Temperature display	Service display	Description	Possible cause/remedy
1	0	Sensor fault S1	<ul style="list-style-type: none"> • Check the wires for breaks • Replace S1
2	0	Sensor fault S2	<ul style="list-style-type: none"> • Check the wires for breaks • Replace S2
3	0	-	-
	0	Sensor fault after self-check	<ul style="list-style-type: none"> • Check the wires for breaks • Replace boiler sensor S1 and/or S2
	1	Temperature too high	<ul style="list-style-type: none"> • Air in system • Pump does not run • Too little circulation in system, radiators closed, pump setting too low
	2	Exchange S1 and S2	<ul style="list-style-type: none"> • Check the cable loom • Replace S1 or S2
	4	No flame signal after 4 ignition attempts	<ul style="list-style-type: none"> • Gas tap closed • Incorrect ignition distance • Gas inlet pressure too low or disappears • Gas valve or ignition unit does not receive voltage
	5	No flame signal after 4 restart attempts	<ul style="list-style-type: none"> • Condensate discharge blocked • Check setting of gas valve
	6	Flame detection fault	<ul style="list-style-type: none"> • Replace ignition cable + spark probe • Replace ignition unit • Replace burner controller
	7	Parameters programmed with computer connection	<ul style="list-style-type: none"> • Reset appliance
	8	Fan speed incorrect	<ul style="list-style-type: none"> • Fan rubs against casing • Wiring between fan and casing • Check the wires for poor contact (tacho signal) • Replace fan
	F or h	Internal fault	<ul style="list-style-type: none"> • Reset the appliance • Earthing fault

8.1 Burner does not ignite

Possible causes		Remedies
Gas tap is closed	⇒ Yes	1. Open the gas tap.
↓ No		
Air in the gas pipe.	⇒ Yes	1. De-aerate the gas pipe.
↓ No		
Inlet pressure too low.	⇒ Yes	1. Contact the gas company.
↓ No		
No ignition	⇒ Yes	1. Replace the ignition probe.
↓ No		
No spark. Ignition unit on gas unit faulty	⇒ Yes	1. Check the cabling. 2. Check the spark probe 3. Replace the ignition unit.
↓ No		
Gas-air control not adjust d properly.	⇒ Yes	1. Check the adjustment, see Gas-air control.
↓ No		
Fan faulty	⇒ Yes	1. Check the wiring. 2. Check the fuse. 3. Replace the fan if necessary.
↓ No		
Fan blockage	⇒ Yes	1. Clean the fan.
↓ No		
Gas valve faulty	⇒ Yes	1. Replace the gas valve. 2. Re-adjust the gas valve, see Gas-air control.

8.2 Burner ignites with much noise

Possible causes		Remedies
Inlet pressure too high.	⇒ Yes	1. The house gas meter may be faulty. Contact the gas company.
↓ No		
Incorrect ignition distance.	⇒ Yes	1. Replace the ignition probe. 2. Check the ignition probe distance.
↓ No		
Gas-air mixture not adjusted properly.	⇒ Yes	1. Check the adjustment. See Gas-air control.
↓ No		
Weak spark.	⇒ Yes	1. Replace the ignition probe. 2. Replace the ignition unit on the gas valve. 3. Check the ignition spark gap.

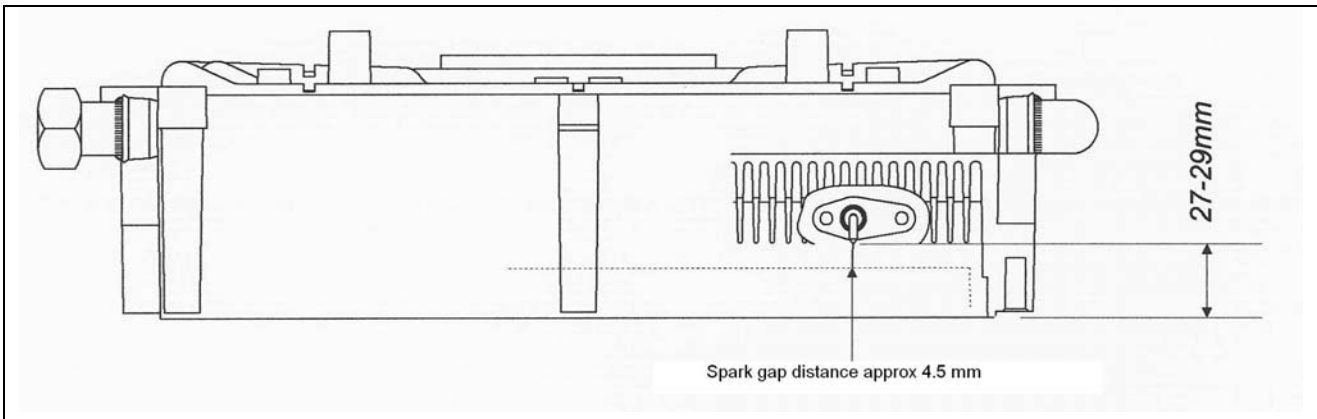

8.3 Burner resonates

Possible causes		Remedies
Inlet pressure too low.	⇒ Yes	1. The house gas meter may be faulty. Contact the gas company.
↓ No		
Re-circulation of the flue gases.	⇒ Yes	1. Check the flue gases and air supply.
↓ No		
Gas-air mixture not adjusted properly.	⇒ Yes	1. Check the adjustment, see Gas-air control.

8.4 No heating (CH)

Possible causes		Remedies
Room thermostat not closed or faulty.	⇒ Yes	1. Check the wiring. 2. Replace the thermostat.
↓ No		
No voltage (24 V).	⇒ Yes	1. Check the wiring according to the diagram. 2. Check the connector x4. 3. Replace defective controller
↓ No		
Pump does not run.	⇒ Yes	1. Check the voltage. 2. Check the connector x4. 3. Replace defective pump. 4. Replace defective controller.
↓ No		
Burner does not operate on CH: - Sensor S1 or S2 faulty.	⇒ Yes	1. Replace sensor S1 or S2. See Fault code display: 1 or 2.
↓ No		
Burner does not ignite.	⇒ Yes	1. See Burner does not ignite.

8.5 Reduced output

Possible causes		Remedies
At high speed, the power has decreased by not more than 5%.	⇒ Yes	<ol style="list-style-type: none"> 1. Check appliance and flue system for pollution. 2. Clean appliance and flue system.

8.6 CH does not reach the correct temperature

Possible causes		Remedies
Room thermostat settings not correct.	⇒ Yes	<ol style="list-style-type: none"> 1. Check the setting and adjust if necessary: set to 0.1 A.
↓ No		
Temperature set too low.	⇒ Yes	<ol style="list-style-type: none"> 1. Raise the CH temperature, see CH operation. 2. Check the outside sensor for short circuit: remedy this..
↓ No		
Pump does not run well. Pump setting too low.	⇒ Yes	<ol style="list-style-type: none"> 1. Raise the pump setting or replace the pump.
↓ No		
No circulation in the system.	⇒ Yes	<ol style="list-style-type: none"> 1. Check for circulation: at least 2 or 3 radiators must be open.
↓ No		
The boiler power is not set well for the system.	⇒ Yes	<ol style="list-style-type: none"> 1. Adjust the power, see Setting maximum CH power.
↓ No		
No heat transfer due to scaling or pollution in the heat exchanger.	⇒ Yes	<ol style="list-style-type: none"> 1. Descale or flush the heat exchanger on the CH side.

Table 6. NTC resistances

NTC 12 kOhm					
T [°C]	R[ohm]	T [°C]	R[ohm]	T [°C]	R[ohm]
-15	76020	25	12000	65	2752
-10	58880	30	9805	70	2337
-5	45950	35	8055	75	1994
0	36130	40	6653	80	1707
5	28600	45	5522	85	1467
10	22800	50	4609	90	1266
15	18300	55	3863	95	1096
20	14770	60	3253	100	952

9. SERVICING THE BOILER

The appliance and the system should be checked by a qualified registered person and cleaned if necessary.

1. Switch off the appliance using the *On/Off* key on the operating panel.
2. Switch off the electrical supply to the appliance.
3. Close the gas tap.
4. Unscrew the two sunken screws left and right at the front underneath the appliance and lift/remove the front panel.
5. Wait until the appliance and the burner have cooled down.
6. Remove the connectors from the gas valve and the fan.
7. Disconnect the coupling beneath the gas valve.
8. Unscrew the 10 socket screws from the front cover and remove this forwards complete with gas valve and fan.

While removing the front cover do not hold this at the gas valve and/or the fan.

Be careful not to damage the burner and the fan while removing the front plate.

The burner does not need any maintenance.

9. Never clean the burner with a brush or compressed air. This causes damage to the metal fibre.
10. Remove the baffles that have been placed crosswise in the fins of the heat exchanger.
11. If necessary, clean the baffles and the fins of the heat exchanger from top to bottom with a brush or with compressed air.
12. If necessary, clean the bottom side of the heat exchanger and the condensate discharge at the bottom of the flue discharge behind the heat exchanger.
13. Clean the siphon and the condensate discharge pipe.
14. After cleaning, fill the siphon with water.
15. Replace the baffles in the heat exchanger.
16. Check the silicone gasket of the front cover for damage (hair)cracks and/or discolouring and replace if necessary.
17. Mount the front cover to the heat exchanger and attach this with the socket screws with spring washers. Crosswise tighten the socket screws evenly by hand. The torque required for the front plate bolts is 10 – 12 Nm.
Make sure that the silicon gasket is well placed around the front cover.
18. Mount the gas coupling below the gas valve.
19. Check the sealing ring for damage and replace if necessary.
20. Fit the connectors on the gas valve and the fan.
21. Open the gas tap and check the gas couplings below the gas valve and on the mounting bracket for leaks.
22. Check the CH and the water pipes for leaks.
23. Switch on the electrical supply to the appliance
24. Put the appliance into operation.
25. Check the front cover and the connection of the fan to the front cover for leaks.
26. Check the gas-air control. See § 7.8.
27. Fit the cover and screw it left and right at the bottom of the appliance.
28. Check the heating system.

10. TECHNICAL SPECIFICATIONS

Appliance category	B13; B33; C13; C 33; C 43; C53; C63; C83
Gas inlet pressure	20 mbar
Suitable for gas	II ₂ H ₃ P

Technical data			
	InterOpen HE 22		

CH			
Nom. load upper value*	kW	7.0 – 26.3	
Nom. load lower value*	kW	6.3 – 23.7	
Nom. power at 80/60°C*	kW	6.1 – 22.7	
Nom. power at 50/30°C*	kW	6.7 – 23.1	
Max. CH water pressure	bar	3	
Max. CH water temperature	°C	90	

Other data			
Gas consumption	m ³ /h	0.66 - 2.29	
Pressure loss appliance	mWk		

Electrical data			
Mains voltage	V	230	
Safety class		IP44 (B(.)=IP20)	
Consumed power: full load	W	40	
Consumed power: partial load	W	15	
Consumed power: standby	W	2.4	

Overall dimensions and weight			
Height	mm	750	
Width	mm	450	
Depth	mm	270	
Weight	kg	34	

*The maximum CH power is set to 50% of the highest value at the factory (see Setting CH power).

10.1 Electrical diagram

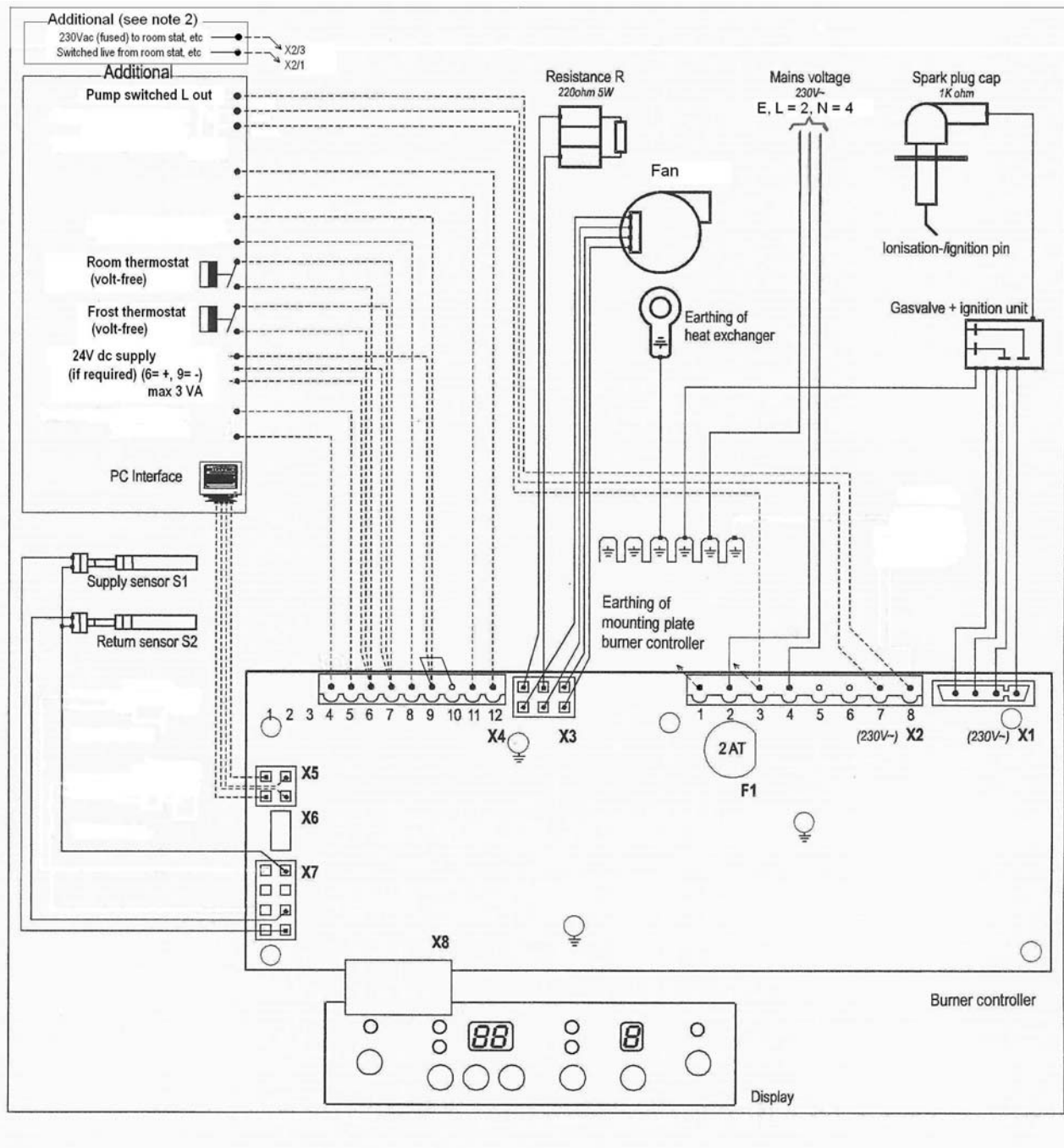

Notes

1. F1: 5x20mm anti-surge fuse, 2A.
2. 230Vac stat circuit: Available for room stat, etc. The switched live can also be used for S plan or Y plan circuits (note that the 230Vac live to the Wiring Centre must come from the same fused spur as the 230Vac supply to the boiler).
3. **External pump:** A switched live output X2/8 (X2/7 = N) is available for a pump if the heating system requires pump overrun. Note that the appliance itself does not require this feature.



11. CE DECLARATION

Declaration of conformity according to ISO IEC GUIDE 22.

Manufacturer: Atmos Heating Systems
Address: West March, DAVENTRY, Northants, NN11 4SA

Hereby declares that the application:

Atmos, Type InterOpen HE22

Meets the stipulations of the following directives:

- Machine directive (89/392/EC) as amended in directive (93/68/EC)
- Low voltage directive (73/23/EC) as amended in directive (93/68/EC)
- Directive concerning gas appliances (90/396/EEG)
- Boilers Efficiency Directive for new oil and gas fired central heating boilers (92/42/EC)
- EMC Directive (89/336/EC) as most recently amended in directive (93/68/EC).

Daventry, 3 October 2005

J.A. Thomason BSc (Eng)
Director

