

Installation and
Operation Instructions for

Mighty Venter Power Vent System

Models MV1 and MV2 for
Mighty Therm Sizes 175-400

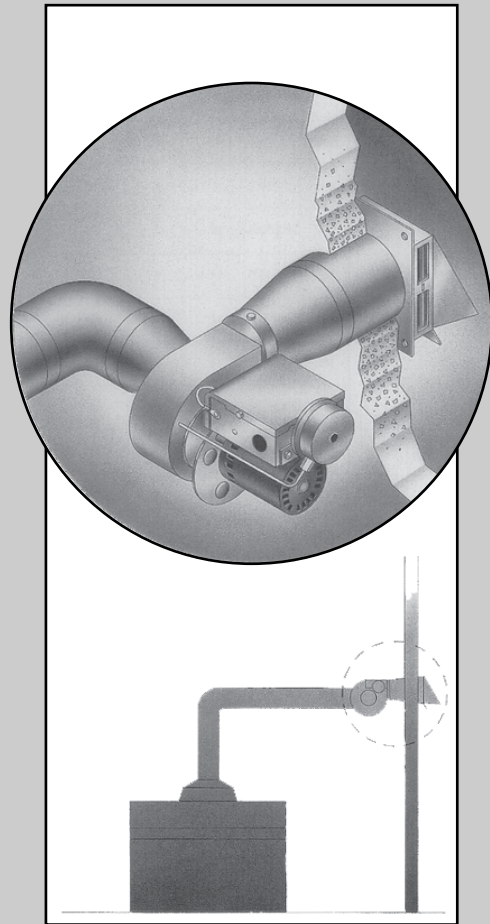

FOR YOUR SAFETY: This product must be installed and serviced by a professional service technician, qualified in hot water boiler and vent system installation and maintenance. Improper installation and/or operation could create carbon monoxide gas in flue gases which could cause serious injury, property damage, or death. Improper installation and/or operation will void the warranty.

⚠WARNING

If the information in this manual is not followed exactly, a fire or explosion may result causing property damage, personal injury or loss of life.

Do not store or use gasoline or other flammable vapors and liquids in the vicinity of this or any other appliance.

WHAT TO DO IF YOU SMELL GAS

- Do not try to light any appliance.
- Do not touch any electrical switch; do not use any phone in your building.
- Immediately call your gas supplier from a nearby phone. Follow the gas supplier's instructions.
- If you cannot reach your gas supplier, call the fire department.

Installation and service must be performed by a qualified installer, service agency, or gas supplier.

TABLE OF CONTENTS

SECTION 1.

1a.	General Information	3
1b.	Vent Sizing	3
1c.	Inspection and Unpacking	3
1d.	Installer Information	3
1e.	Installation Restrictions	4

SECTION 2.

Side Wall Vent Hood Location

2a.	Side Wall Vent Hood Location	4
-----	------------------------------------	---

SECTION 3.

Electrical Wiring

3a.	Safety Interlock Test	8
3b.	Maintenance	8

SECTION 1.

1a. General Information

⚠WARNING

The MV1 and MV2 Mighty Venter must be installed in accordance with the procedures outlined in these instructions. Warranty applies only if the installation and operating instructions applicable to the model purchased are expressly and completely followed.

The Laars Mighty Venter, Models MV1 and MV2, are designed to make side-wall venting possible for Laars hot water boilers, Models HH, PH, VW and PW, sizes 175 - 400. Both the MV1 and MV2 are equipped with a fan-prover switch which disables the gas valve if the Power Venter fails to operate.

The Mighty Venter installation must comply with the latest edition of the National Fuel Gas Code, ANSI Z223.1, and in Canada, CAN1-B149.1 or .2 and all local codes that apply. The installation must include the draft hood assembly shipped with the boiler, including vent damper if required.

1b. Vent Sizing

Take into consideration the dimensions in Table 1 when designing the vent system. The vent pipe length shown includes all vent pipe before and after the Power Venter.

1c. Inspection and Unpacking

Immediately upon receiving the Mighty Venter kit, inspect the shipment packaging for damage. Record any damage on the shipping documents. Unpack the equipment and carefully inspect it for obvious damage caused in shipment. If any damage is found, YOU must file a claim with the transporter. The transporter will not accept a claim from the shipper, Laars Heating Systems.

The Mighty Venter kit includes three cartons:

- Carton 1. Power Venter (MV1 or MV2)
- Carton 2. Vent Hood
- Carton 3. Vent Reducers/Adapter

Verify the contents of each carton by checking against the parts list on page 8.

1d. Installer Information

1. Before beginning the installation, read these instructions completely and make sure each part is placed to safely vent flue gases to the outdoors.
2. Carefully read the installation instructions located in the Side Wall Vent Hood carton.
3. Laars does not provide the vent pipe necessary for this installation. Use Table 1 as an aid in selecting the proper vent pipe diameter.
4. Locate the Power Venter as close as possible to the point of termination (i.e., the wall). This will insure the vent pipe between the boiler and the Power Venter inlet is under negative pressure.
5. Make sure the power supply is adequate for the Power Venter motor requirements. Do not add the Power Venter to a circuit where the total load is unknown.

⚠Caution

To prevent personal injury and equipment damage, disconnect the power supply to the hot water boiler when working on the Power Venter.

Mighty Venter Model	Boiler/Heater Size	Mighty Venter Order Number	Boiler/Heater Outlet Diameter		Vent Pipe Diameter		Minimum Equivalent Pipe Length		Maximum Equivalent Pipe Length		Mighty Venter Diameter	
			in	mm	in.	mm	feet	m	feet	m	in	mm
MV1	175	10718702	6	152	4	102	11	3.4	90	27.4	4	102
MV1	250	10718703	7	178	6	152	11	3.4	100	30.5	4	102
MV2	325	10718704	8	203	6	152	11	3.4	100	30.5	6	152
MV2	400	10718705	9	229	6	152	11	3.4	100	30.5	6	152

Notes:

1. Table 1 is for single boiler installations only.
2. To calculate the equivalent vent pipe length, add the length of the straight pipe plus 10 feet (3.0m) for every 90° elbow and 5 feet (1.5m) for every 45° elbow.
3. Vent pipe reducers will be supplied by Laars.

Table 1. Critical Vent Sizing Data.

1e. Installation Restrictions

1. Make sure minimum clearances from combustible materials required by code are maintained.

IMPORTANT: The following clearances to combustible materials must be maintained for the Power Venter:

Sides: 6-inches (152mm)
Back: 8-inches (203mm)

2. All vent pipe connections between the Power Venter and the Vent Hood will be under positive pressure during operation, and must be sealed to prevent leakage into the building.
3. To prevent bearing wear, and for proper Fan-Prover Switch operation, make sure the Power Venter motor shaft is horizontal (see Fig. 1).
4. The ambient temperature surrounding the Power Venter must not exceed 104°F (40°C).
5. The venting system must be sloped upwards not less than 1/4 inch per foot from the boiler to the vent terminal. The vent system must be installed to prevent the collection of condensate where necessary, and must be provided with a means of drainage.
6. Condensate lines or single wall exhaust vent shall not be run through an unheated space or interior part of an open chimney unless the exhaust vent is insulated.

7. The vent system must be adequately supported to prevent sagging, but in no case shall the supports be less than every 3 feet (0.9m).
8. Inlet and outlet piping must conform to Figure 4, 5 or 6.
9. Do not place any elbows within two feet of venter outlet.

SECTION 2.

2a. Side Wall Vent Hood Location

If possible, locate the side wall vent hood on a wall not normally subjected to high winds. This will lessen the possibility of gas valve interruption during periods when the winds are stronger than 40 MPH (64 kmh). The Vent Hood location must comply with the following specifications (see Fig. 2):

⚠ Caution

Flue gas temperature can exceed 150°F (66°C) depending on the appliance being vented and the length of the vent system. Do not terminate a side wall vent system where vinyl siding has been installed on the building exterior, since damage to the vinyl siding may result.

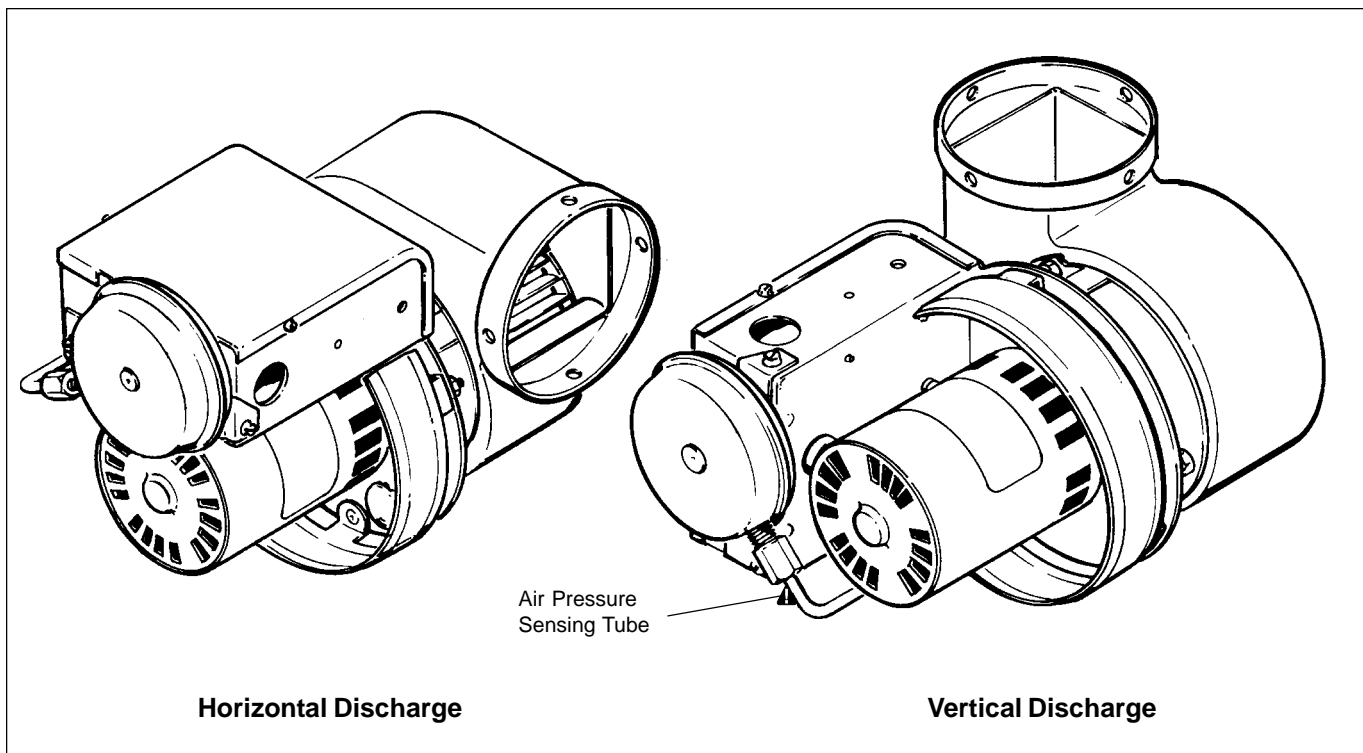

Figure 1. Discharge Options.

1. Locate the Vent Hood a minimum of 7 feet (2.1m) above a public walkway.
2. Locate the Vent Hood a minimum of 3 feet (0.9m) above, or 4 feet (1.2m) below and 4 feet (1.2m) horizontally from any door, window, or gravity air inlet into the building. The Vent Hood cannot terminate less than 6 feet (1.8m) above any forced air inlet located within 10 feet (3.0m).
3. The Vent Hood must be installed at least 3 feet (0.9m) from any other building opening or any gas service regulator.
4. Do not install the vent hood closer than 2 feet (0.6m) from an adjacent building.
5. Install the Vent Hood no closer than 3 feet (0.9m) from an inside corner of an L-shaped structure.
6. Do not terminate the Vent Hood directly above a gas utility meter or service regulator.

CODE REQUIREMENTS

The Power Venter installation must be in accordance with the following requirements of the National Fuel Gas Code:

All portions of the vent system under positive pressure during operation (on the outlet side of the Power Venter) shall be designed and installed so as to prevent leakage of flue or vent gases into a building.

The boiler must enter the vent system on the inlet side of the Power Venter.

Provision shall be made to interlock the boiler(s) to prevent the flow of gas to the main burners when the draft system is not performing so as to satisfy the operating requirements of the equipment for safe performance. See the "Electrical Wiring" section in this manual for details.

Power Venter Installation

The Power Venter must be mounted with the motor shaft horizontal to ensure proper operation of the Fan-Prover switch and prevent motor bearing wear (see Fig. 1). The installer must supply plumber's strap or threaded rod with nut and washers for mounting.

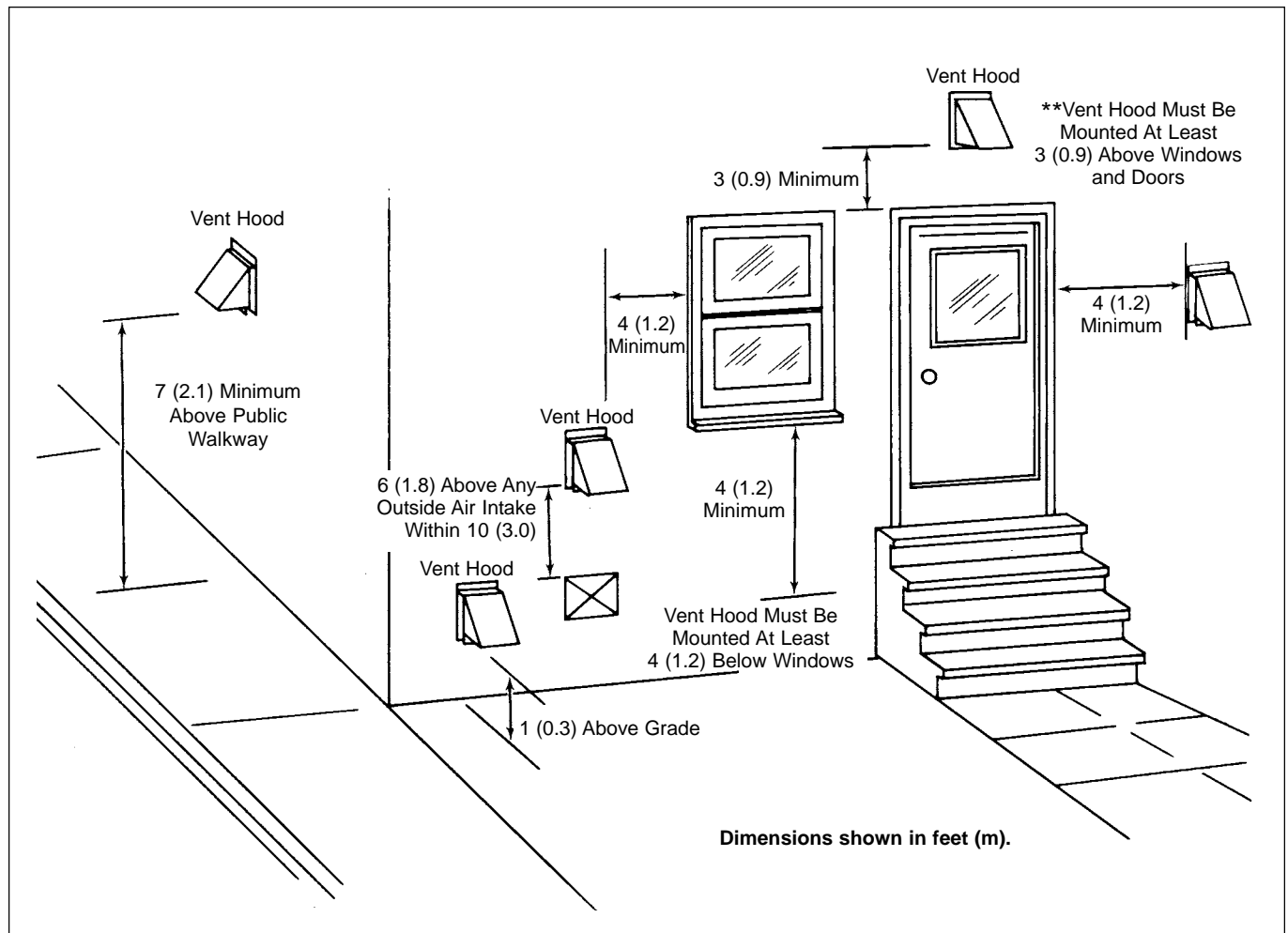

Figure 2. Side Wall Vent Hood Locations.

To facilitate installation and reduce vibration, 2 mounting brackets, 2 rubber isolators, and 2 rubber grommets are included. One of the brackets can be used as a temporary “third hand” while positioning it for permanent installation (see Figure 3).

When installing the Power Venter for horizontal discharge, install one of the brackets to the electrical box using the nut/screw provided. Install the other to the damper rod. When installing the Power Venter for vertical discharge, only one bracket is needed. Mount this bracket to the motor as shown in Figure 3.

SECTION 3. Electrical Wiring

⚠WARNING

All wiring from the Power Venter to the appliance must comply with local codes, or in their absence, the National Electric Code (NFPA #70) in the United States and/or CSA C22.1 Electrical Code in Canada.

Disconnect 115 VAC power to the appliance before proceeding with wiring the Power Venter. The power can be disconnected by tripping the circuit breaker or removing the fuse protecting the appliance. All wiring must comply with applicable codes and ordinances. All 115 VAC wiring must be rigid or semi-rigid metal conduit with 18 AWG, 300 VAC, 90° C rated copper wire.

Fig. No.	Boiler Size	Boiler Draft Hood Outlet	Vent Pipe Dia.	Vent Hood Dia.	Rough-in Dim.
4	175	6"	4"	4"	8.0" Dia.
5	250	7"	6"	6"	9.0" Dia.
6	325	8"	6"	6"	9.0" Dia.
6	400	9"	6"	6"	9.0" Dia.

Table 2.

Wire the hot water boiler and the Power Venter exactly as shown in Figure 7 and follow these steps:

1. Connect the black and white (115 VAC) wires from the Power Venter to the boiler control box as shown in Figure 7.
2. Connect the red, blue and yellow (24 VAC) wires to the terminal block as shown in Figure 7. Make sure the current capacities of the wires, switches, etc. at 115 VAC meet the ratings in Table 3.
3. Remove factory-installed jumper from between boiler terminals 3 and 4.

Model	Power Venter Motor HP	Equivalent Full Load Currents (Amps - 115 VAC)
MV1	1/25	1.3
MV2	1/8	4.4

Table 3. Electrical Ratings.

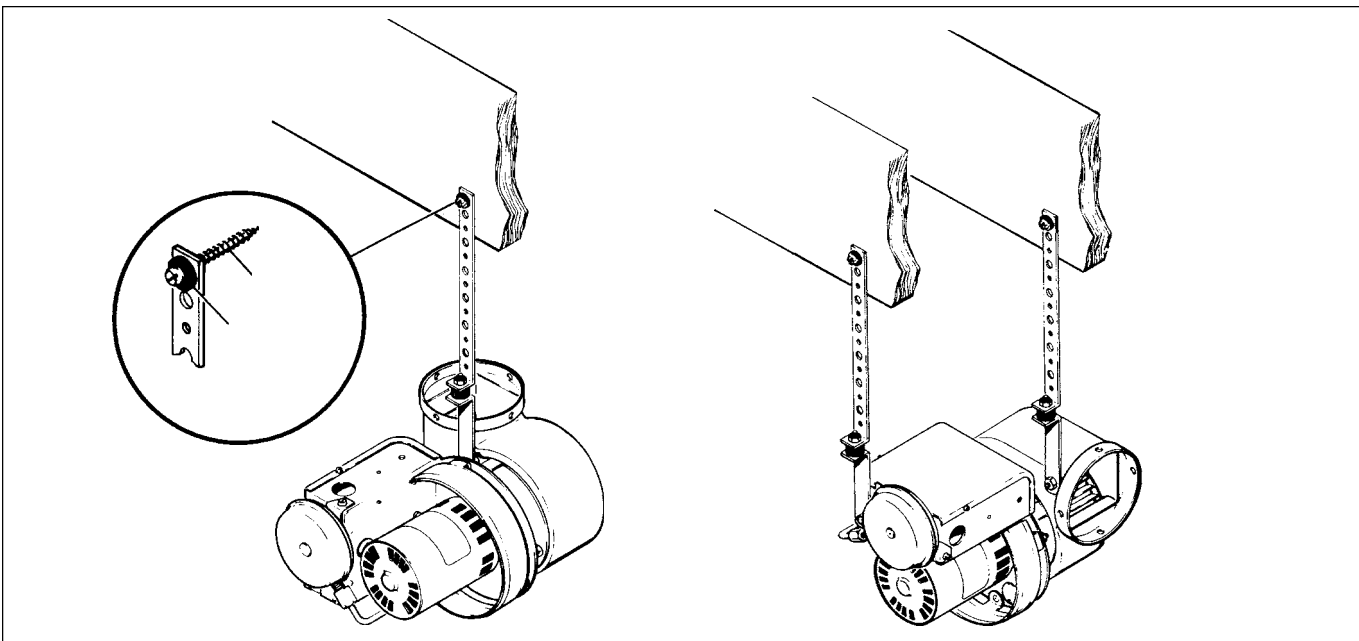

Figure 3. Power Venter Discharge Options.

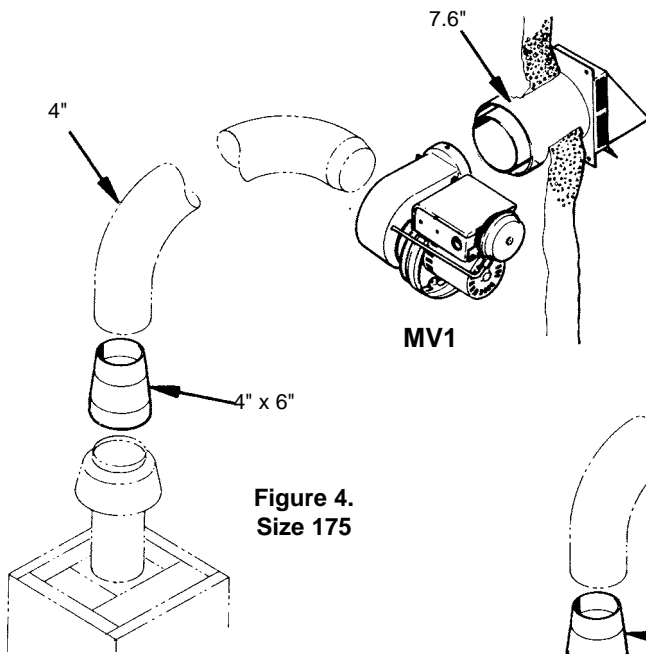

Figure 4.
Size 175

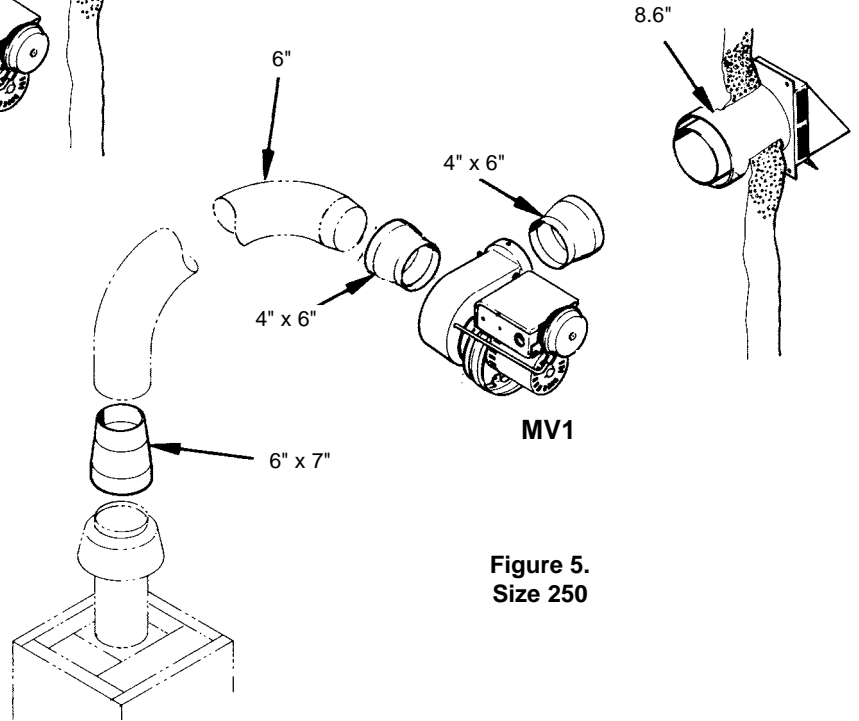

Figure 5.
Size 250

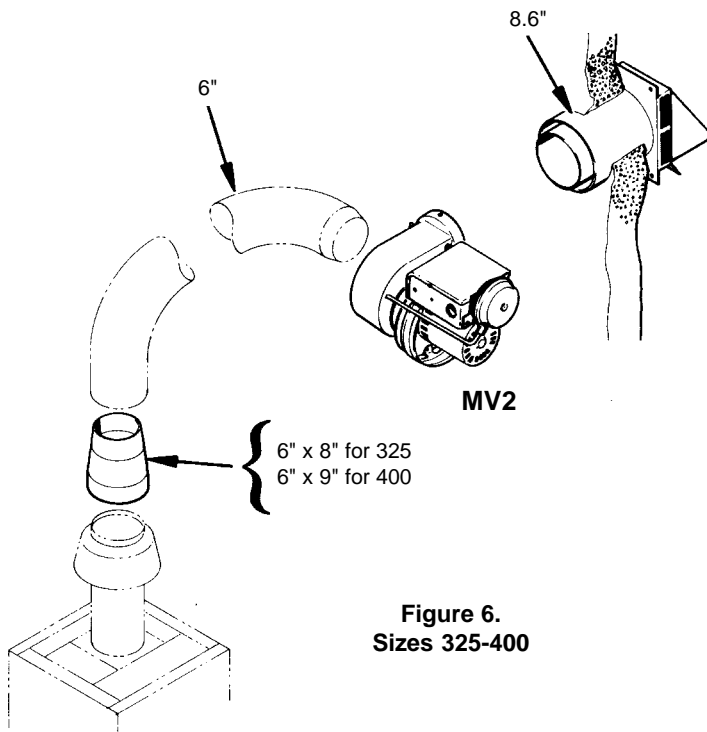

Figure 6.
Sizes 325-400

3a. Safety Interlock Test

1. Turn the appliance thermostat/aquastat high enough to call for heat.
2. Verify by fan rotation that the Power Venter begins operating before the gas valve becomes energized.
3. With the appliance firing and the Power Venter operating, disrupt power to the Power Venter by removing one of the black wires from the Power Venter relay. Make sure the appliance gas valve turns off.

⚠ WARNING

Do not operate the boiler that does not shut off when the Power Venter is disabled.

3b. Maintenance

1. Oil the motor every six months with 2 drops of S.A.E. #20 oil. The oil ports are located on top of the motor.
2. Laars recommends that the boiler system be checked annually by a qualified service technician. The inspection should include checking all vent pipe and connections for blockage and leaks, and a safety interlock test.

Parts List

Part Number	Description	Boiler Size
10718702	Mighty Venter Kit (MV1)	175
D2008801	Power Venter	
D0019700	Vent Hood, 7.6" Dia.	
D0018800	4" x 6" Reducer (Qty. 1)	
10718703	Mighty Venter Kit (MV1)	250
D2008801	Power Venter	
D0019800	Vent Hood, 8.6" Dia.	
D0018900	6" x 7" Reducer (Qty. 1)	
D0018800	4" x 6" Reducer (Qty. 2)	
10718704	Mighty Venter Kit (MV2)	325
D2008802	Power Venter	
D0019800	Vent Hood, 8.6" Dia.	
D0019000	6" x 8" Reducer (Qty. 1)	
10718705	Mighty Venter Kit (MV2)	400
D2008802	Power Venter	
D0019800	Vent Hood, 8.6" Dia.	
D0019100	6" x 9" Reducer (Qty. 1)	

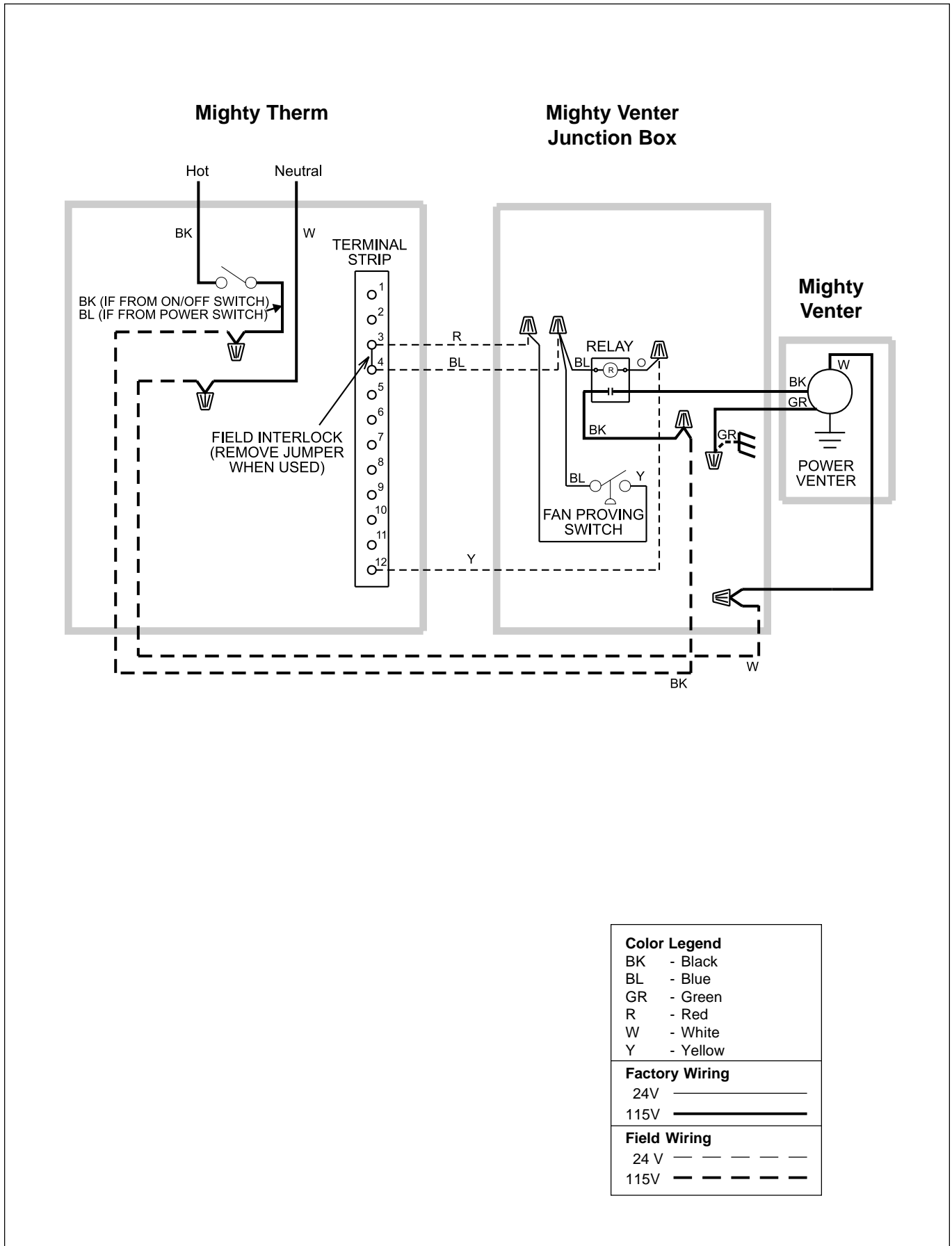
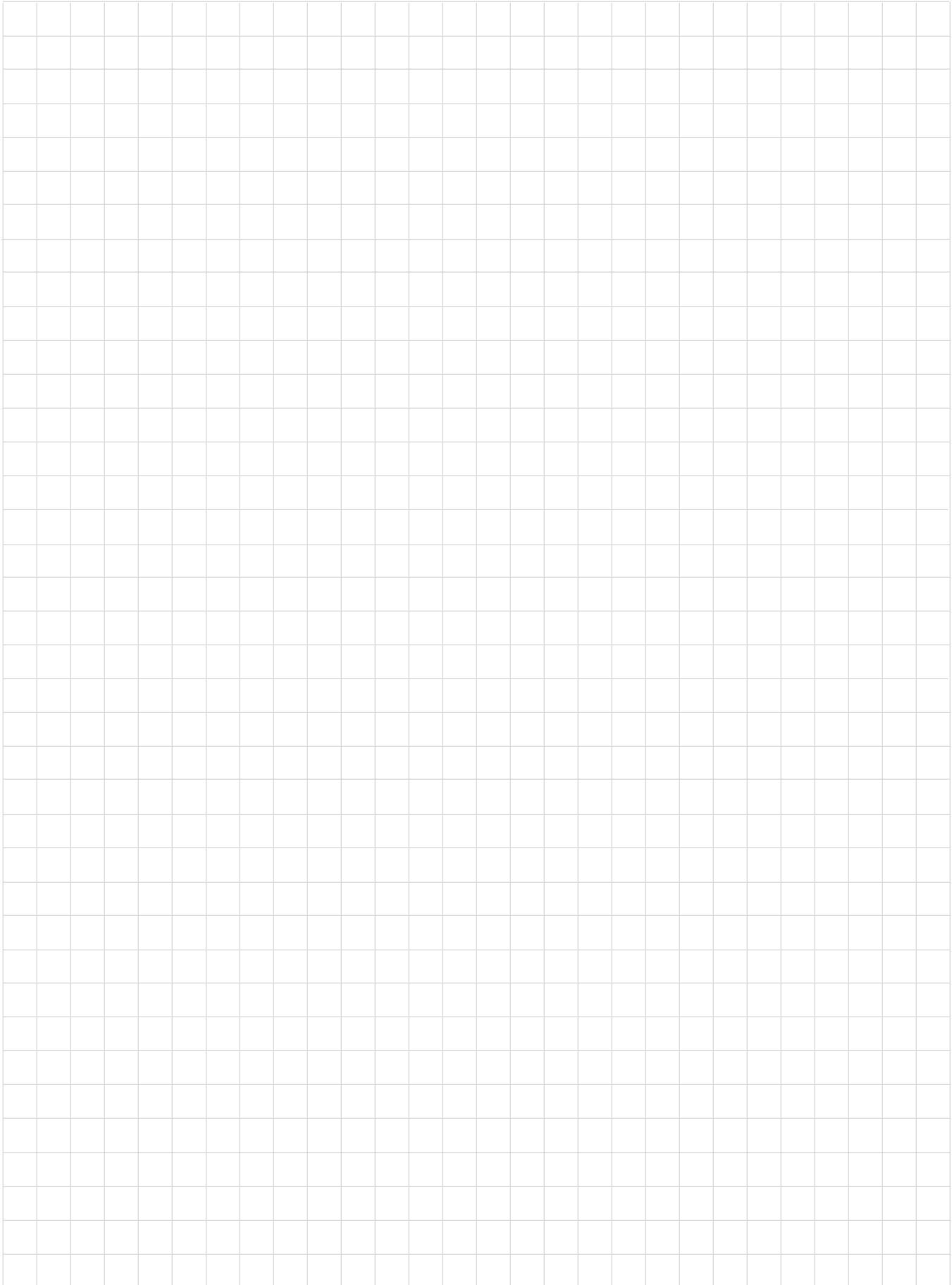
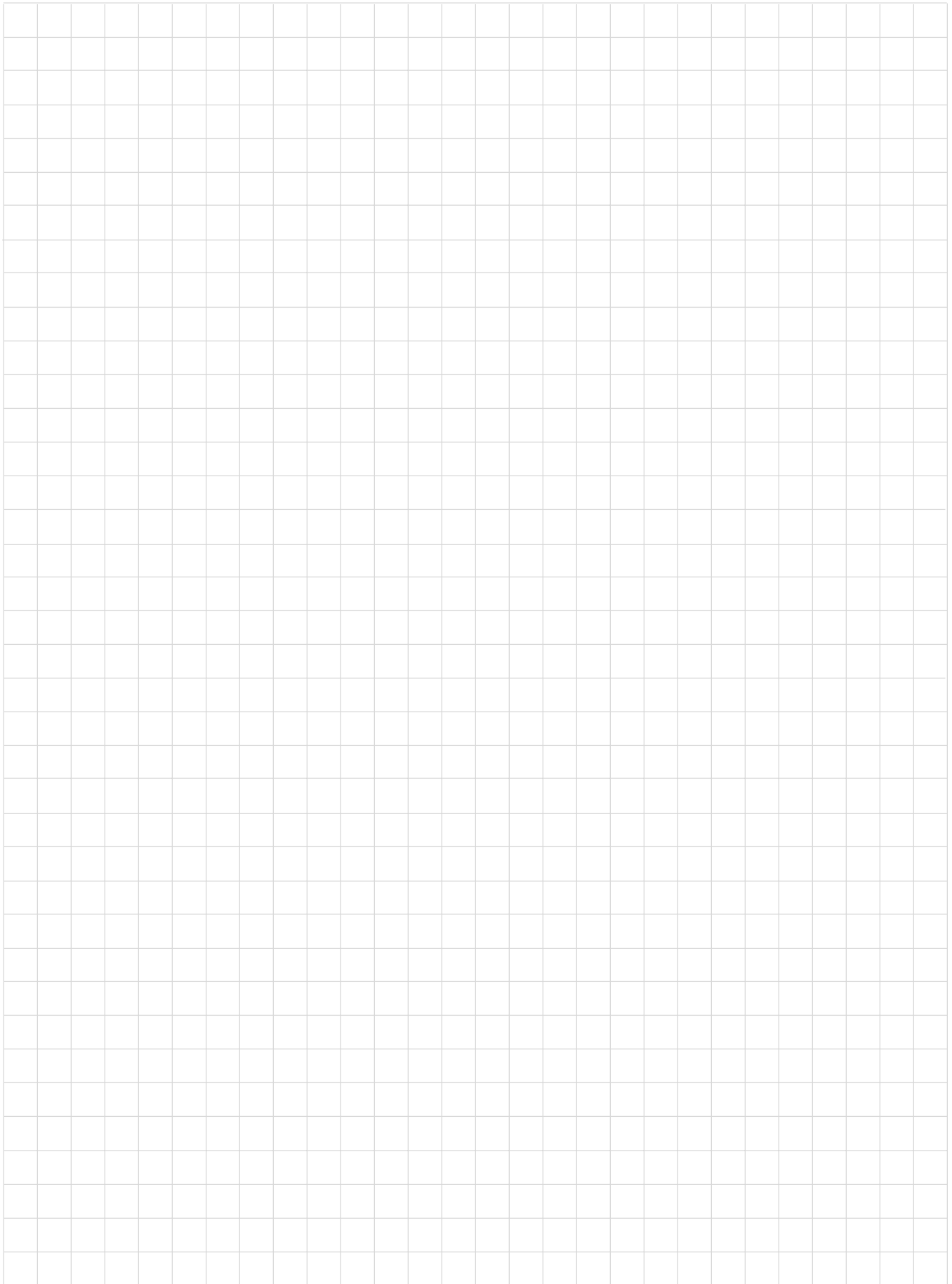

Figure 7. Wiring Diagram For Mighty Therm, Model HH, PH, VW, PW, Sizes 175 through 400.





Laars Heating Systems Mighty Venter™ Power Vent System

Your Laars Mighty Venter Power Vent System is backed by this warranty to assure your complete satisfaction.

Laars warrants the Mighty Venter; the motor, fan prover switch and sheet metal parts to be free of defects in materials and workmanship for 18 months from date of purchase or 12 months from date of installation, whichever comes first.

The above warranty applies only if the installation and operating instructions applicable to the model purchased are expressly and completely followed. These instructions are furnished with the unit and are also available by writing to the Laars factory. The liability of Laars shall not exceed the repair or replacement of defective parts by factory authorized technicians, and shall not include transportation to or from factory, any labor costs, and consequential or incidental damages. Ship inoperative parts or complete system with Serial

number, Model number and purchase date, transportation prepaid, directly to address below, attention Customer Service, for evaluation and warranty consideration.

This warranty gives you specific legal rights. You may also have other rights which vary from state to state, and by province. Some states and provinces do not allow the exclusion or limitation of incidental or consequential damages, so the above limitation or exclusion may not apply to you.



H0168800D