

UK

ENSURE THAT THESE INSTRUCTIONS ARE LEFT
FOR THE USER AFTER COMPLETION OF THE
BENCHMARK SECTION

PLANET DEWY 60-100 BFR

*Installation and
servicing instructions*



199838



Please read the Important Notice within
this guide regarding your boiler warranty



IMPORTANT NOTICE

For the first year all of our appliances are protected by our manufacturer's guarantee which covers both parts and labour.

As you would expect from Sime Ltd, it is our aim to provide our valued customers with the best in after sales and service.

To take advantage of any extended warranty offered, all you have to do is to adhere to these 3 simple conditions:

- The installation must be carried out to Manufacturers/Benchmark Standards by a Gas Safe Registered Engineer, and recorded in the installation manual.
- The appliance must be registered with both Sime Ltd and Gas Safe within 30 days of installation.
- The appliance must be serviced annually, by either Sime Ltd or a Gas Safe registered engineer- ensuring that the Benchmark service record in the installation manual is completed.

Failure to comply with the above will result in only the 12 month warranty being offered.

In the absence of any proof of purchase, the 12 month warranty period will commence from the date of manufacture of the boiler as shown on the appliance data plate.

SAFE HANDLING

This boiler may require 2 or more operatives to move it into its installation site, remove it from its packaging and during movement into its installation location. Manoeuvring the boiler may include the use of a sack truck and involve lifting pushing and pulling.

Caution should be exercised during these operations.

Operatives should be knowledgeable in handling techniques when performing these tasks and the following precautions should be considered:

- Grip the boiler at the base
- Be physically capable
- Use personal protective equipment as appropriate e.g. gloves, safety footwear.

During all manoeuvres and handling actions, every attempt should be made to ensure the following unless unavoidable and/or the weight is light.

- Keep back straight
- Avoid twisting at the waist
- Always grip with the palm of the hand
- Keep load as close to the body as possible
- Always use assistance

WARNING

Caution should be exercised when performing any work on this appliance.

Protective gloves and safety glasses are recommended.

- Avoid direct contact with sharp edges.
- Avoid contact with any hot surfaces.

NOTICE

Please be aware that due to the wet testing of the appliance, there may be some residual water in the hydraulic circuit.

- Protect any surfaces, carpets or floorings.
- Use a suitable container to catch any water that escapes when removing the protective caps from the connections.

Code Of Practice

For the installation, commissioning and servicing
of domestic heating and hot water products

Benchmark places responsibilities on both manufacturers and installers.* The purpose is to ensure that customers** are provided with the correct equipment for their needs, that it is installed, commissioned and serviced in accordance with the manufacturer's instructions by competent persons and that it meets the requirements of the appropriate Building Regulations. Installers are required to carry out work in accordance with the following:

Standards of Work

- Be competent and qualified to undertake the work required.
- Install, commission, service and use products in accordance with the manufacturer's instructions provided.
- Ensure that where there is responsibility for design work, the installation is correctly sized and fit for purpose.
- Meet the requirements of the appropriate Building Regulations. Where this involves notifiable work be a member of a Competent Persons Scheme or confirm that the customer has notified Local Authority Building Control (LABC), prior to work commencing.
- Complete all relevant sections of the Benchmark Checklist/Service Record when carrying out commissioning or servicing of a product or system.
- Ensure that the product or system is left in a safe condition and, whenever possible, in good working order.
- Highlight to the customer any remedial or improvement work identified during the course of commissioning or servicing work.
- Refer to the manufacturer's helpline where assistance is needed.
- Report product faults and concerns to the manufacturer in a timely manner.

Customer Service

- Show the customer any identity card that is relevant to the work being carried out prior to commencement or on request.
- Give a full and clear explanation/demonstration of the product or system and its operation to the customer.
- Hand over the manufacturer's instructions, including the Benchmark Checklist, to the customer on completion of an installation.
- Obtain the customer's signature, on the Benchmark Checklist, to confirm satisfactory demonstration and receipt of manufacturer's instructions.
- Advise the customer that regular product servicing is needed, in line with manufacturers' recommendations, to ensure that safety and efficiency is maintained.
- Respond promptly to calls from a customer following completion of work, providing advice and assistance by phone and, if necessary, visiting the customer.
- Rectify any installation problems at no cost to the customer during the installer's guarantee period.



*The use of the word "installer" is not limited to installation itself and covers those carrying out installation, commissioning and/or servicing of heating and hot water products, or the use of supporting products (such as water treatment or test equipment).

**Customer includes householders, landlords and tenants.

The Benchmark Scheme

Sime Ltd is a licensed member of the Benchmark Scheme which aims to improve the standards of installation and commissioning of domestic heating and hot water systems in the UK and to encourage regular servicing to optimise safety, efficiency and performance.

Benchmark is managed and promoted by the Heating and Hotwater Industry Council.
For more information visit www.centralheating.co.uk

FONDERIE SIME S.p.A. of Via Garbo 27 - Legnago (VR) - Italy declares that its hot water boilers, which bear the CE mark under Gas Directive 90/396/CEE and are fitted with a safety thermostat calibrated to a maximum of 110°C, **are not subject** to application of PED Directive 97/23/CEE as they meet the requirements of article 1 paragraph 3.6 of the Directive.



Planet Dewy 60 BFR: Gas Council number 41-283-03

Planet Dewy 100 BFR: Gas Council number 41-283-11

These appliances comply with the S.E.D.B.U.K. scheme, band "A"

CONTENTS

1	DESCRIPTION OF THE BOILER	pag. 6
2	INSTALLATION	pag. 9
3	CHARACTERISTICS	pag. 20
4	USE, MAINTENANCE (including BENCHMARK) AND COMMISSIONING	pag. 24
5	EXPLODED VIEWS	pag. 32

Important Information

IT IS A STATUTORY REQUIREMENT THAT ALL GAS APPLIANCES ARE INSTALLED BY COMPETENT PERSONS, IN ACCORDANCE WITH THE GAS SAFETY (INSTALLATION AND USE) REGULATIONS (CURRENT EDITION). The manufacturer's instructions must not be taken as overriding any statutory requirements, and failure to comply with these regulations may lead to prosecution.

No modifications to the appliance should be made unless they are fully approved by the manufacturer.

GAS LEAKS: DO NOT OPERATE ANY ELECTRICAL SWITCH, OR USE A NAKED FLAME. TURN OFF THE GAS SUPPLY AND VENTILATE THE AREA BY OPENING DOORS AND WINDOWS CONTACT THE GAS EMERGENCY SERVICE ON 0800111999.



"60 BFR single boiler only"

Please refer to commissioning instructions for filling in the checklist at the back of this installation guide.

Note: All Gas Safe registered installers carry a ID Card.

You can check your installer is Gas Safe Registered by calling 0800 408 5577

IMPORTANT

When carrying out commissioning of the boiler, you are highly recommended to perform the following checks:

- Make sure that there are no liquids or inflammable materials in the immediate vicinity of the boiler.
- Make sure that the electrical connections have been made correctly and that the earth wire is connected to a good earthing system.
- Open the gas valve and check the soundness of the connections, including that of the burner.
- Make sure that the boiler is set for operation for the type of gas supplied.
- Check that the flue pipe for the outlet of the products of the combustion is unobstructed and has been properly installed.
- Make sure that any shutoff valves are open.
- Make sure that the system is charged with water and is thoroughly vented.
- Check that the circulating pump is not jammed.
- Purge the system, bleeding off the air present in the gas pipe by operating the pressure relief valve on the gas valve inlet.
- Complete the Benchmark checklist included in this manual.

1 DESCRIPTION OF THE BOILER

1.1 INTRODUCTION

“PLANET DEWY BFR” boilers are pre-mixed condensation heating modules intended only for heating, designed to work singularly or in sequence/cascade auto-

mously. They are supplied as **class B** devices, but can easily be converted to **class C** (room sealed) with the addition of an air intake pipe. They are designed and constructed to meet European directives 2009/142/CEE, 2004/108/CEE,

2006/95/CEE and 92/42/CEE.

As a single boiler it can be controlled by a simple timer/thermostat or with Logica. A RVA controller is available to manage up to 6 boilers in sequence or cascade.

1.2 DIMENSIONS

1.2.1 PLANET DEWY 60 BFR (fig. 1)

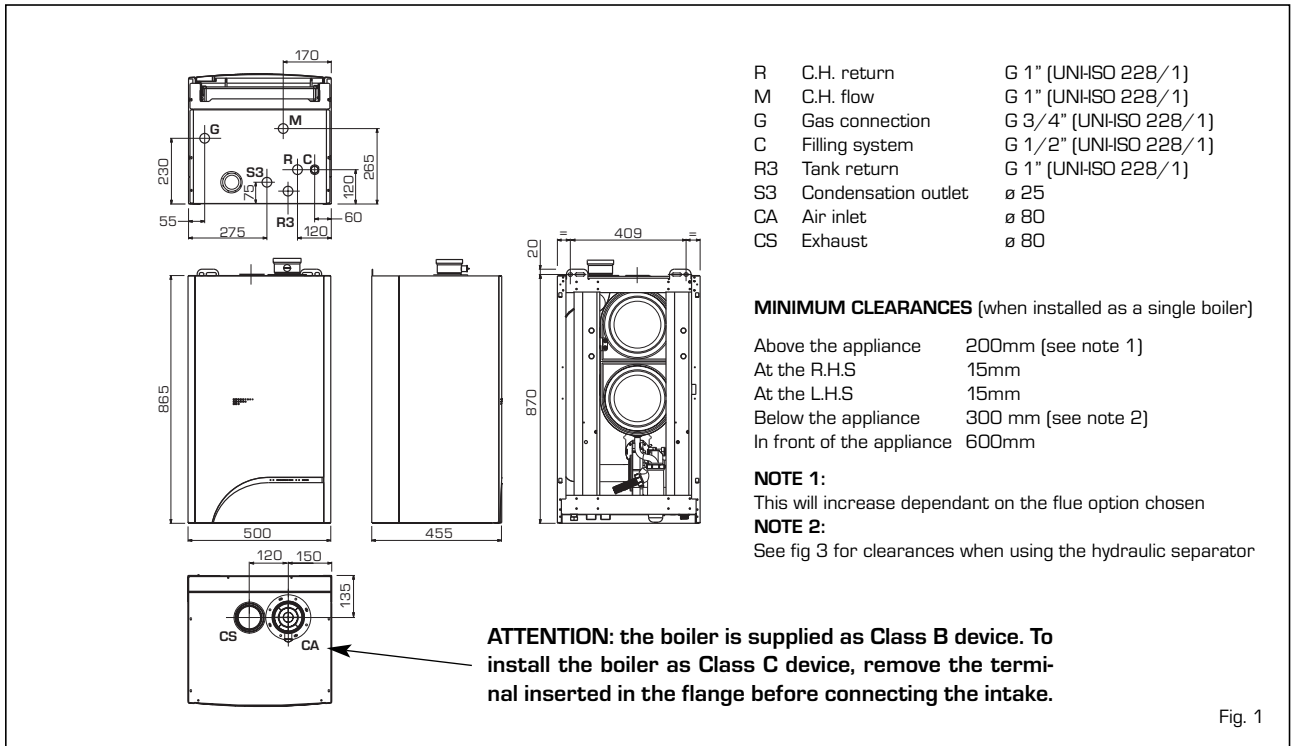

1.2.2 PLANET DEWY 100 BFR (fig. 1/a)

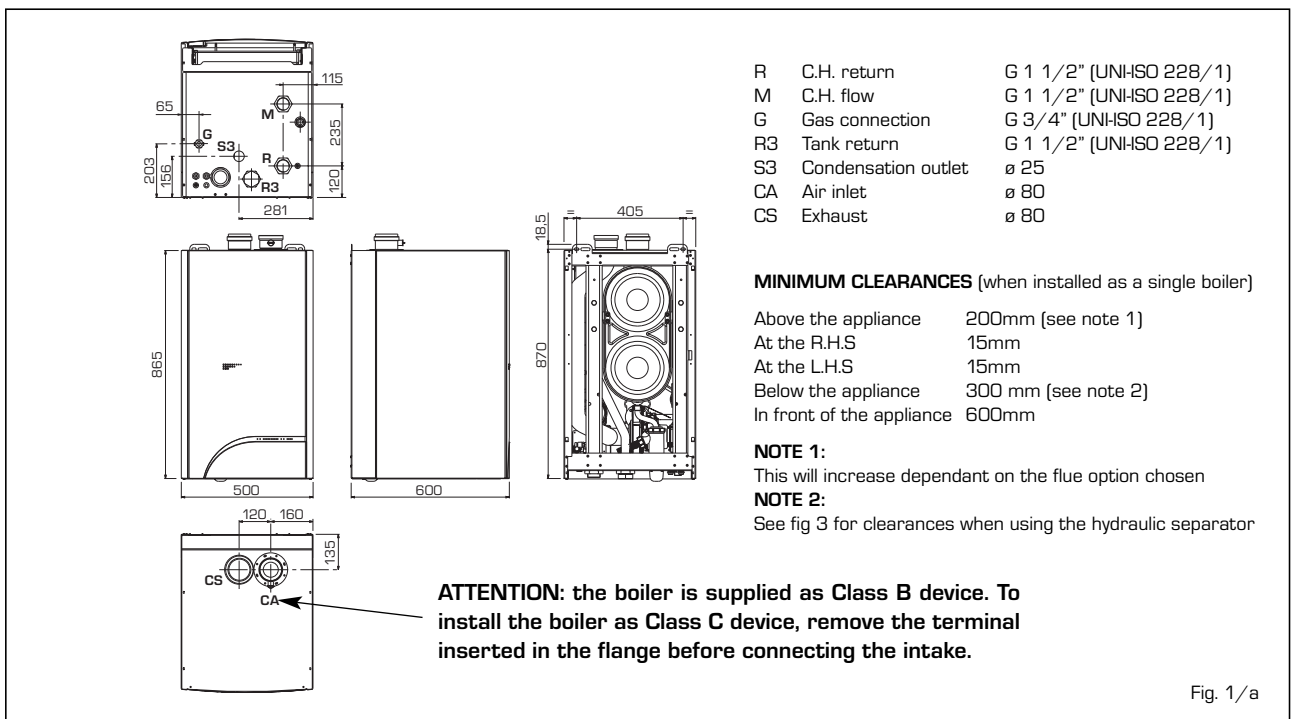

1.3 MAIN COMPONENTS

1.3.1 PLANET DEWY 60 BFR (fig. 2)

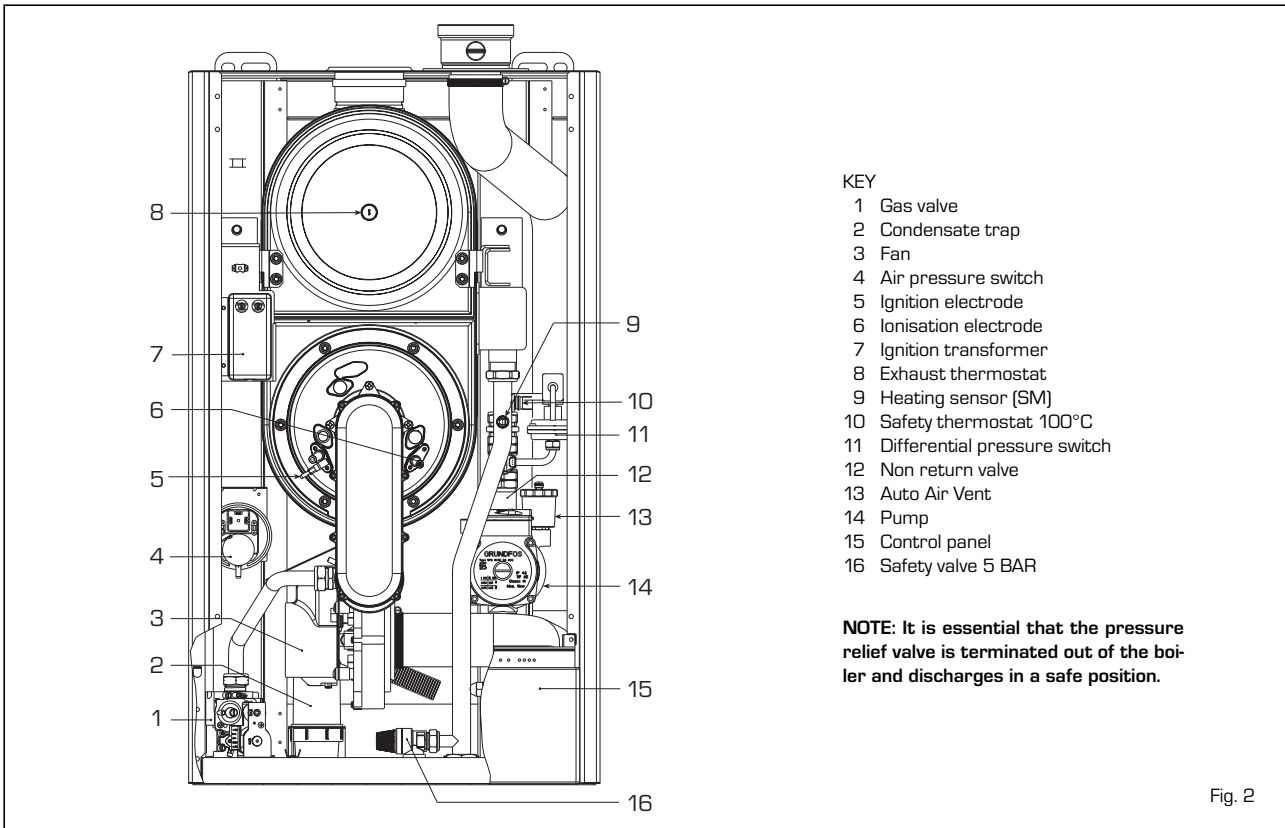

1.3.2 PLANET DEWY 100 BFR (fig. 2/a)

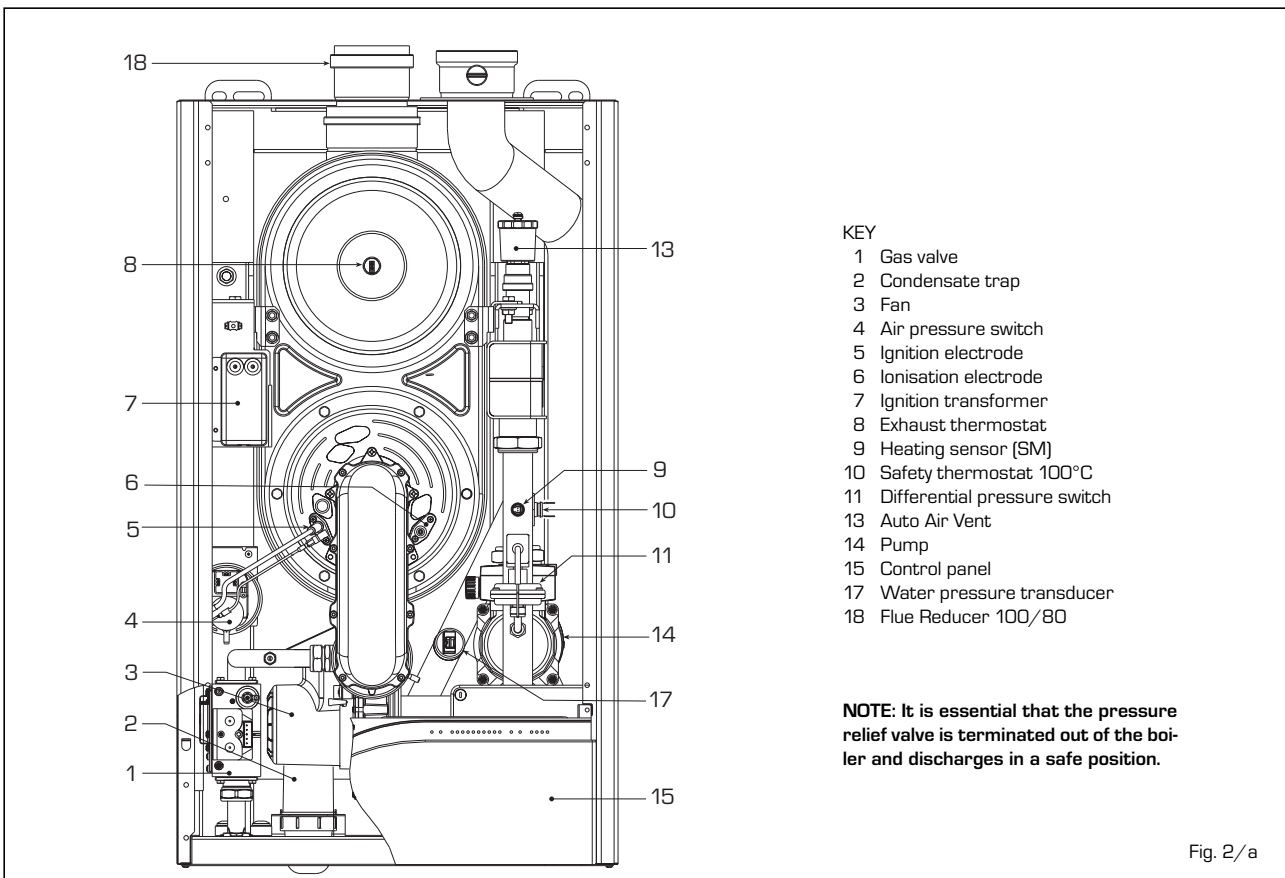

1.4 TECHNICAL FEATURES

		PLANET DEWY 60 BFR	PLANET DEWY 100 BFR
Heat output nominal (80-60°C)	kW (kcal/h)	56.5 (48,600)	94.2 (81,000)
Heat output nominal (50-30°C)	kW (kcal/h)	62.0 (53,400)	103.0 (88,600)
Heat output minimum G20 (80-60°C)	kW (kcal/h)	17.0 (14,600)	28.2 (24,250)
Heat output minimum G20 (50-30°C)	kW (kcal/h)	19.0 (16,300)	31.3 (26,900)
Heat output minimum G31 (80-60°C)	kW (kcal/h)	22.6 (19,500)	28.2 (24,250)
Heat output minimum G31 (50-30°C)	kW (kcal/h)	25.4 (21,800)	31.3 (26,900)
Nominal heat output	kW (kcal/h)	58.0 (49,900)	96.6 (83,100)
Minimum heat output G20	kW (kcal/h)	17.4 (15,000)	28.9 (24,850)
Minimum heat output G31	kW (kcal/h)	23.2 (19,900)	28.9 (24,850)
Efficiency minimum/nominal output (80-60°C)	%	97.6 - 97.5	97.7 - 97.5
Efficiency minimum/nominal output (50-30°C)	%	109.3 - 107.0	108.8 - 106.4
30% yield (40-30°C)	%	109.8	109.0
Termal efficiency (CEE 92/42 directive)		★★★★	★★★★
Class NOx		5	5
Smokes temperature maximum (80-60°C)	°C	70	70
Smokes temperature minimum (80-60°C)	°C	62	62
Smokes temperature maximum (50-30°C)	°C	50	50
Smokes temperature minimum (50-30°C)	°C	32	32
Smokes flow	kg/h	97	166
CO ₂ maximum/minimum G20	%	9.0/9.0	9.0/9.0
CO ₂ maximum/minimum G31	%	10.0/10.0	10.0/10.0
Maximum pressure exhaust manifold output	Pa	110	170
Adsorbed power consumption	W	198	330
Electrical protection grade		IPX4D	IPX4D
Losses after shutdown at 50°C	W	134	195
CE certification	n°	1312BP4141	1312BP4141
Category		II2H3P	II2H3P
Type		B23-53 / B23P-53P / C13-33-43-53-83	B23-53 / B23P-53P / C13-33-43-53-83
C.H.			
Maximum water head	bar	4	5
Maximum temperature	°C	85	85
Water content boiler	l	4.8	8.2
C.H. setting range (D.H.W. setting range)	°C	20/80 (30/60)	20/80 (30/60)
GAS PRESSURE END NOZZLES			
Gas supply pressure G20/G25	mbar	20/25	20/25
Gas supply pressure G31	mbar	37	37
Nozzles quantity	n°	1	1
Nozzles diameter G20/G25	ø	9,3	11.0
Nozzles diameter G31	ø	6,7	8.4
Gas consumption nominal/minimum G20	m ³ /h	6.14/1.84	10.22/3.06
Gas consumption nominal/minimum G31	kg/h	4.51/1.80	7.50/2.25
WEIGHT	kg	61	92

2 INSTALLATION

The boiler must be installed in a fixed location and only by qualified engineers in compliance with all instructions contained in this manual. Furthermore, the installation must be in accordance with current standards and regulations.

whose size and requirements meet current regulations.

The boiler can be installed as class B devices in boiler rooms with air vents direct to the outside. See ventilation requirements in the use and maintenance section.

heat exchanger is mandatory.

For single installations, order an optional compensator kit (code 8101530 for the version "60 BFR" and cod. 8101531 for the version "100 BFR").

2.1 BOILER ROOM

The boilers can be installed in boiler rooms

2.2 INSTALLATION (fig. 3)

The use of a hydraulic separator or plate

For cascade installations hydraulic separators are available to suit the number and size of the boilers being installed.

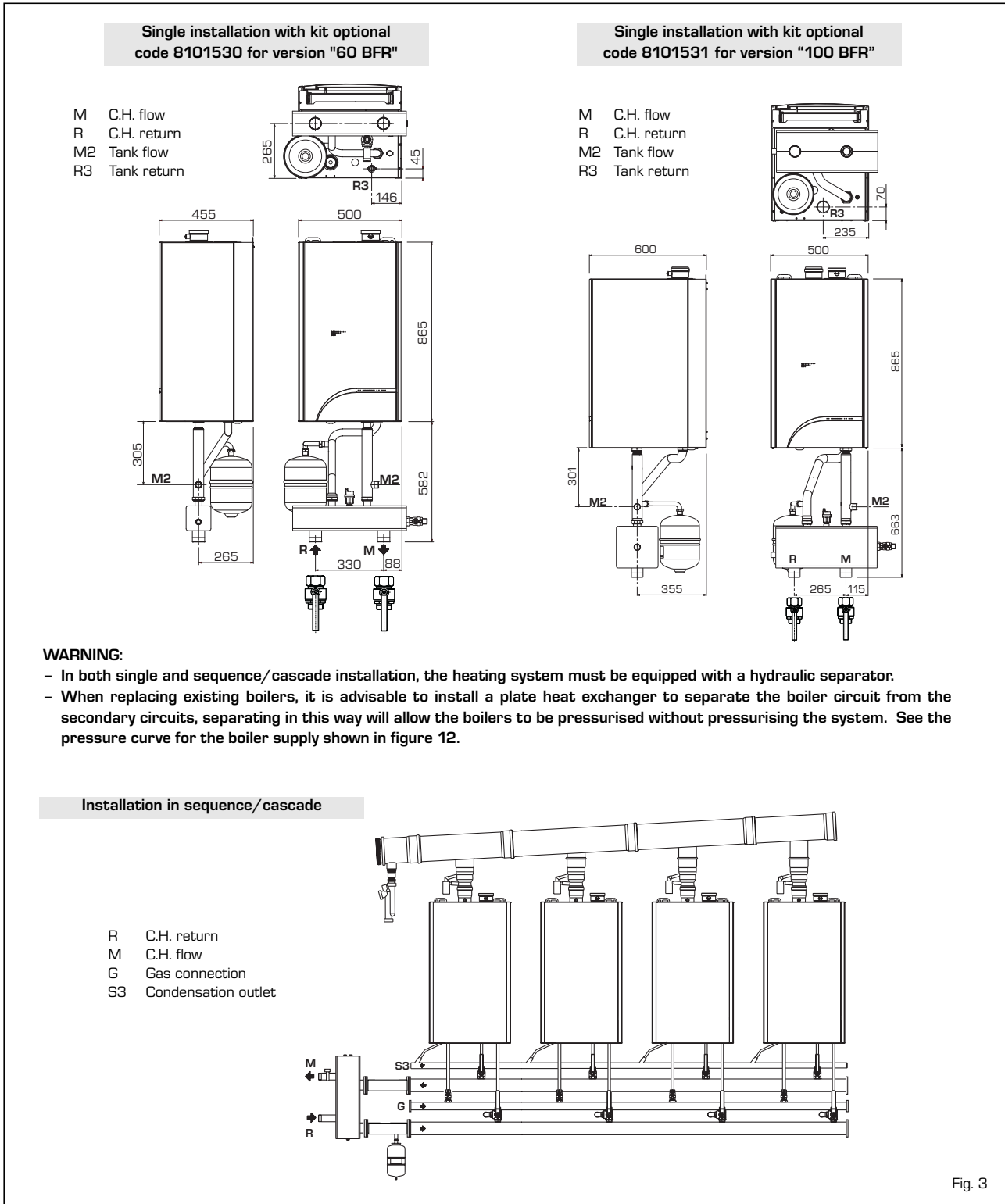

Fig. 3

2.3 CONNECTING UP SYSTEM

To protect the heat exchanger from being damaged by corrosion, incrustation or deposits, after installation it is extremely important to clean the system using suitable products. Sime Ltd recommend only the use of FERNOX products for the flushing and final treatment of the system water.

This is particularly important in hard water areas.

Artificially softened water must not be used to fill the heating system. It is important to check the concentration of the inhibitor after each system modification and during maintenance following the manufacturer's instructions (specific tests are available at your dealer).

The safety valve drain must be connected to a collection funnel to collect any discharge during interventions.

WARNING: Failure to clean or adequately treat the heating system could invalidate the warranty.

Gas connections must be made in accordance with current standards and regulations. When dimensioning gas pipes from the meter to the module, both capacity volume (consumption) in m³/h and gas density must be taken into account.

The sections of the piping making up the system must be such as to guarantee a supply of gas sufficient to cover the maximum available output of the boiler; limiting pressure loss between the gas meter and any appa-

ratus being used to not greater than:

- 1.0 mbar for family II gases (natural gas);
- 2.0 mbar for family III gases (butane or propane).

A sticker inside the module includes identification and gas type data specific to the module.

2.3.1 Condensation drain installation

A siphoned drain must be connected to the civil drain by a pipe with minimum 5 mm per meter gradient for condensation collection.

Only normal plastic civil drain pipes are suitable to convey condensation to the building's sewer drain.

2.3.2 Gas pipe filter

The gas valve is fitted with a standard filter. This filter is not capable of filtering all impurities and to prevent poor gas valve operation or failure of any gas valve safety feature, it is advisable to fit a suitable filter on the gas supply pipe.

2.4 FILLING THE SYSTEM

Cold system filling pressure must be 1 bar. The system must be filled slowly so that air bubbles are released through the specific escapes.

2.5 EXHAUST

The boiler is supplied with a 80mm gasket, which must be fitted over the exhaust terminal prior to the flue being installed. (11 fig. 4 - 4/a - 4/b).

The flue should be fitted and terminated in accordance with BS 6644, IGE/UP/!O part 1, Edition 2, BS5440 -1 and the clean air act as applicable.

2.5.1 Type B (fig. 4)

If the inlet is not connected, the boiler should be regarded a Class B device. When installing the boiler in locations where it needs to be protected from water, replace the intake terminal inserted in the flange with terminal code 8089510. For information on how to configure the boiler in this mode see figure 4.

The maximum overall length of ø 80 exhaust flues is determined by the load losses of the single accessories installed and should not exceed 16 mmH₂O ("60 BFR") and 28 mmH₂O ("100 BFR").

2.5.2 Type C (fig. 4/a - fig. 4/b)

The boiler becomes a Class C device when the intake terminal is removed from the flange and the intake is connected to separate exhaust ducts (fig. 4/a) or with coaxial exhaust (fig. 4/b).

Type B

KEY

- 1 90° MF polypropylene curve (6 pcs.) code 8077450
- 2 a Polypropylene extension L.1000 (6 pcs.) code 8077351
- 2 b Polypropylene extension L. 500 (6 pcs.) code. 8077350
- 3 Articulated tile code 8091300
- 4 Roof terminal kit L. 1285 code 8091212A
- 5 Polypropylene extension L. 250 with test outlet code 6296513
- 6 45° MF polypropylene curve (6 pcs.) code. 8077451
- 7 Exhaust terminal code 8089501
- 8 Internal-external ring nut kit code 8091500
- 11 Rubber gasket ø 80 (supplied as standard)

ø 80 ACCESSORY LOAD LOSS TABLE

	Load loss (mm H ₂ O)	
	"60 BFR"	"100 BFR"
90° MF polypropylene curve	1.30	3.00
45° MF polypropylene curve	0.70	2.00
Polypropylene extension L. 1000	0.60	1.20
Polypropylene extension L. 500	0.30	0.60
Roof exit terminal L. 1381	1.20	4.30
Exhaust terminal	1.30	3.60
Polypropylene extension L. 250	0.15	0.30

WARNING: Before installing accessories, lubricate the internal part of gaskets with silicon-based products. Avoid using oils and greases.

Fig. 4

Type C (separate \varnothing 80 flues and coaxial exhaust terminal)

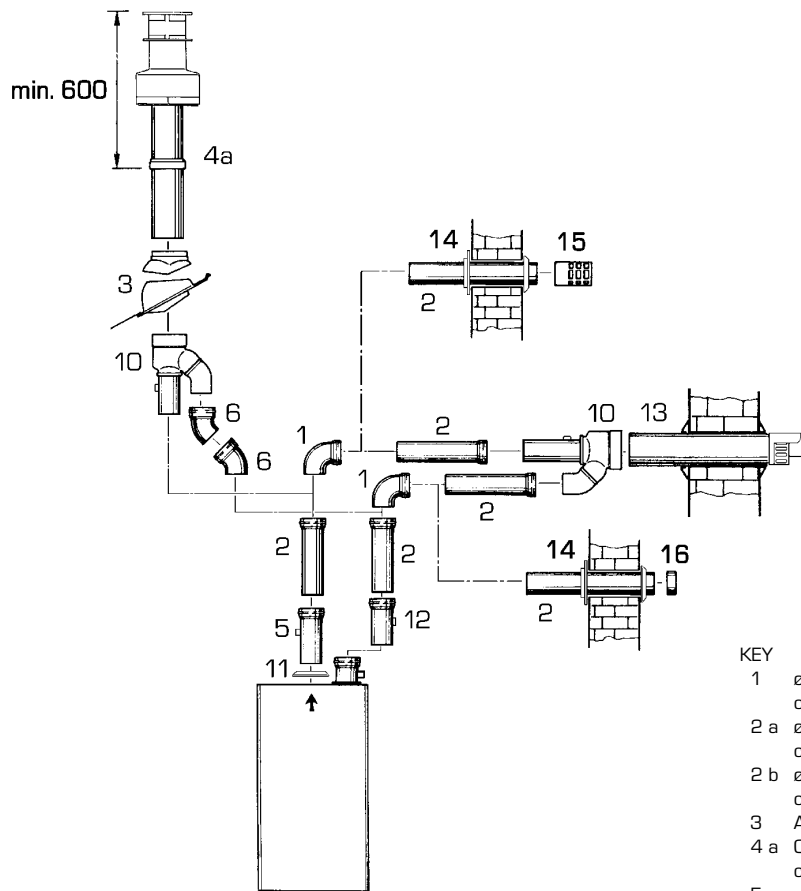

KEY

- 1 \varnothing 80 curve, 90° MF (6 pcs), code 8077450, (single 8077450A)
- 2 a \varnothing 80 extension, L. 1000 (6 pcs.), code 8077351, (single 8077351A)
- 2 b \varnothing 80 extension, L. 500 (6 pcs.), code 8077350, (single 8077350A)
- 3 Articulated tile, code 8091300
- 4 a Coaxial roof exit terminal, L. 1285, code 8091212A
- 5 \varnothing 80 extension, L. 250, with test point, code 6296513
- 6 \varnothing 80 curve, 45° MF (6 pcs.), code 8077451, (single 8077451A)
- 10 Inlet/exhaust fitting, code 8091401
- 11 \varnothing 80 rubber gasket (supplied with unit)
- 12 \varnothing 80 condensation recovery, L. 135, code 8092800
- 13 \varnothing 80/125 coaxial exhaust, L. 885, code 8096253A
- 14 Internal-external wall seals (two pairs), code 8091500
- 15 Air inlet terminal, code 8089500
- 16 Exhaust terminal, code 8089501

WARNING:

- Installations with roof exit terminal (4a) and coaxial exhaust (13) require the use of a condensation recovery (12) that has to be connected to the water drain siphon (waste water).
- Before fitting the accessories, it is always advisable to lubricate the internal section of the gaskets with silicon products and generally avoid the use of oils and greases.

TABLE OF LOAD LOSSES OF ACCESSORIES

	Load loss (mm H ₂ O)			
	"60 BFR"		"100 BFR"	
	Inlet	Exhaust	Inlet	Exhaust
90° MF polypropylene curve	1.00	1.30	2.00	3.00
45° MF polypropylene curve	0.60	0.70	1.50	2.00
Polypropylene extension, L. 1000	0.60	0.60	1.20	1.20
Polypropylene extension L. 500	0.30	0.30	0.60	0.60
Coaxial roof exit terminal, L. 1285 + Fitting (pos. 10)	-	4.30	-	14.00
Roof exit terminal L. 1381	-	1.20	-	4.30
Exhaust terminal	-	1.30	-	3.60
Air inlet terminal	0.20	-	1.60	-
Polypropylene extension, L. 250 with socket	-	0.15	-	0.30
Coaxial exhaust, L. 885 + Fitting (pos. 10)	-	5.20	-	15.00
Condensation recovery, L. 135	2.50	-	5.00	-

Fig. 4/a

Type C (ø 80/125 coaxial exhaust)

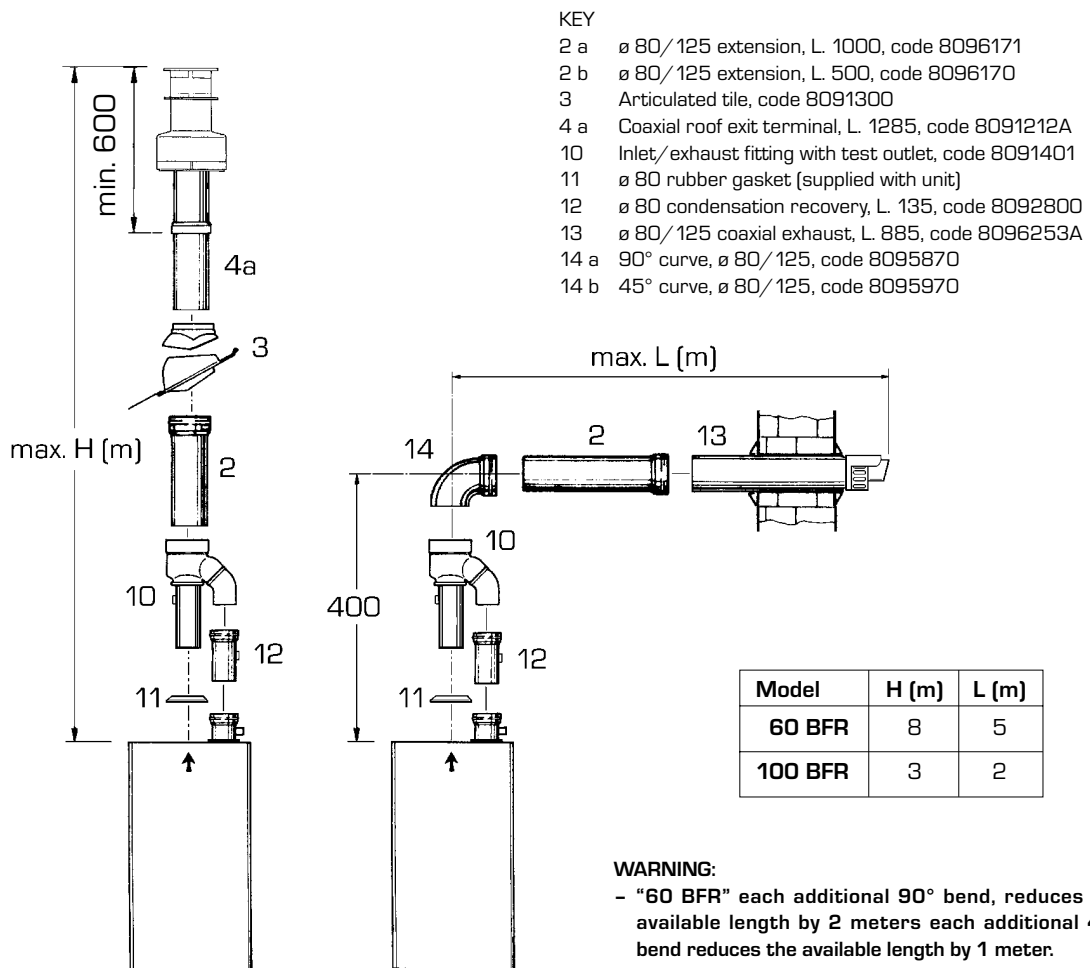

NOTES:

- Installation requires the use of a condensation recovery (12) that must be connected to a water drain siphon (waste water).
- Before fitting the accessories, it is always advisable to lubricate the internal section of the gaskets with silicon products and generally avoid the use of oils and greases.
- Horizontal flues and terminals must be LEVEL.

WARNING:

- "60 BFR" each additional 90° bend, reduces the available length by 2 meters each additional 45° bend reduces the available length by 1 meter.
- "100 BFR" additional bends are not permitted.

Fig. 4/b

2.5.3 Maximum usable length for separate ø 80 flues

The maximum overall length of ø 80 suction and exhaust flues is determined by the load losses of the single accessories installed and should not exceed 16 mmH₂O ("60 BFR") and 28 mmH₂O ("100 BFR").

When the length of the flues ranges between 11 and 16 mm H₂O ("60 BFR") - 17 and 27 mm H₂O ("100 BFR"), it is necessary to adjust trimmer "MAX" on the fan board and set the "Max. air Δp" values provided in paragraph 4.1 in order to ensure a correct operation.

2.5.4 Maximum usable length for coaxial ø 80/125 flues

In installations with ø 80/125 coaxial exhaust, the maximum horizontal length including the 90° curve, should not exceed 5 m ("60 BFR") and 2 m ("100 BFR"). For roof exits it should not exceed 8 m along vertical for the version "60 BFR" and 3 m along vertical for the version "100 BFR".

In the version "60 BFR" when the length of the flue ranges from 2 to 5 m horizontally and from 4 to 8 m vertically, it is necessary to adjust trimmer "MAX" on the fan board and set the "Max. air Δp" values provided in paragraph 4.1 in order to ensure a correct

operation. In the version "100 BFR" for all pipe lengths it is necessary to adjust trimmer "MAX" on the fan board and set the "Max. air Δp" values provided in paragraph 4.1 in order to ensure a correct operation.

2.5.5 Positioning the outlet terminals

The terminals for forced-draught appliances may be located in the external perimeter walls of the building.

To provide some indications of possible solutions, table gives the minimum distances to be observed, with reference to the type of building shown in fig. 5.

Flue termination positions, condensing room sealed, fan flued boilers

All measurements are in mm and are minimum clearances.

Terminal Location	Boilers with a rated Input < 70kW	Boilers with a rated Input > 70kW	
	Net	Net	
A	*Below and opening window etc.	300	600
B	Below gutter soil pipes etc.	75	700
C	Below Eaves.	200	200
D	*Below balconies or car port roof.	200	N/A
E	From vertical drain or soil pipe etc.	150	150
F	From internal or external corners.	300	300
G	Above ground or balcony level.	300	300 (2000 where people have general access)
H	From a surface facing the terminal.	2000	2000
I	From a terminal facing the terminal.	2000	2000
J	*From opening in a carport into a dwelling.	1200	N/A
K	Vertically from a terminal on the same wall.	1500	1500
L	Horizontally from a terminal on the same wall.	300	600
M	Above an opening, window etc.	500	600
N	*Horizontally to an opening, window etc.	300	600
P	Above a level roof (base of terminal.)	500	500
Q	From an adjacent wall (edge of terminal.)	500	500
R	From adjacent opening, window etc.	1000	1000
S	From any other flue terminal.	600	600

* Positions not recommended.

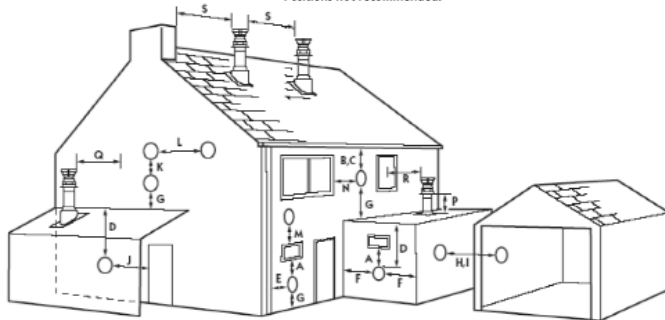

Groups of appliances of 150kW gross input (136kW net input) and above must comply with the Clean Air Act with respect to the chimney discharge height.

The terminal's shall be guarded if it is less than 2000mm above the ground or in any position where it may cause injury to persons resulting from touching a hot surface.

Document intended for quick guidance only. Absolute guidance must be sought from the respective regulation.

Fig. 5

2.6 ELECTRICAL CONNECTION

The boiler is supplied with an electric cable. Should this require replacement, it must be purchased exclusively from SIME.

The electric power supply to the boiler must be 230V - 50Hz single-phase through a fused main switch fitted with a 3 amp fuse, with at least 3 mm spacing between contacts. Respect the L and N polarities and the earth connection.

NOTE: SIME declines all responsibility for injury or damage to persons, animals or property, resulting from the failure to provide for proper earthing of the appliance.

2.6.1 External Control (fig. 6 pos. A)

To gain access to the electronic board connector (3), remove the control panel cover and connect any voltage free control (timer, programmable room thermostat or heat demand) to the terminals TA after having removed the jumper. The control, must be class II as specified by standard EN 60730.1 (clean contact).

WARNING: Applying mains voltage to the terminals of connector (3) will irreparably damage the control board. Make sure that any connections to be made are not carrying mains voltage.

2.6.2 Logica Remote Control connection (fig. 6 pos. B)

The electrical control must comply with local standards and all cables must comply with low safety voltage requirements of EN 60730. For lengths up to 25 m, use cables of section 0.25 mm², for longer lengths up to 50 m use cables of section 0.5 mm². First of all, assemble and wire the socket (2), then insert the equipment which will start-up as soon as it receives current. To gain access to connector (3) remove the control panel cover and connect the climate regulator to terminals CR the "Albatros" connector (15 fig 11) will need to be removed for operation with Logica.

WARNING: External voltage must not be connected to terminals 1-2-3-4 of the Logica Remote Control.

2.6.3 External temperature sensor connection (fig. 6 pos. C)

The cables must comply with low safety voltage requirements of EN 60730. For lengths up to 25 m, use cables of section 0.25 mm², for longer lengths up to 50 m use cables of section 0.5 mm². To gain access to boiler connector (3) remove the control panel cover and connect the external temperature sensor to terminals SE.

KEY

- 1 Control panel
- 2 Logica Remote Control socket
- 3 Conector (J2)
- CR Logica Remote Control (optional)
- SE External temperature sensor (optional)

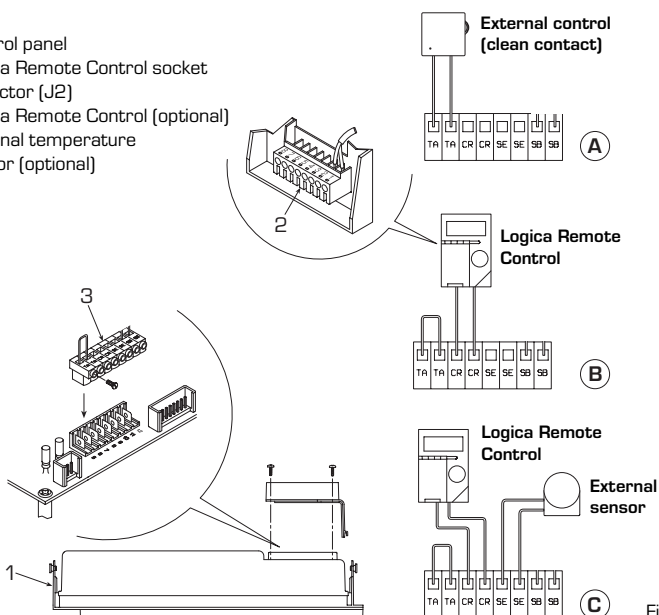
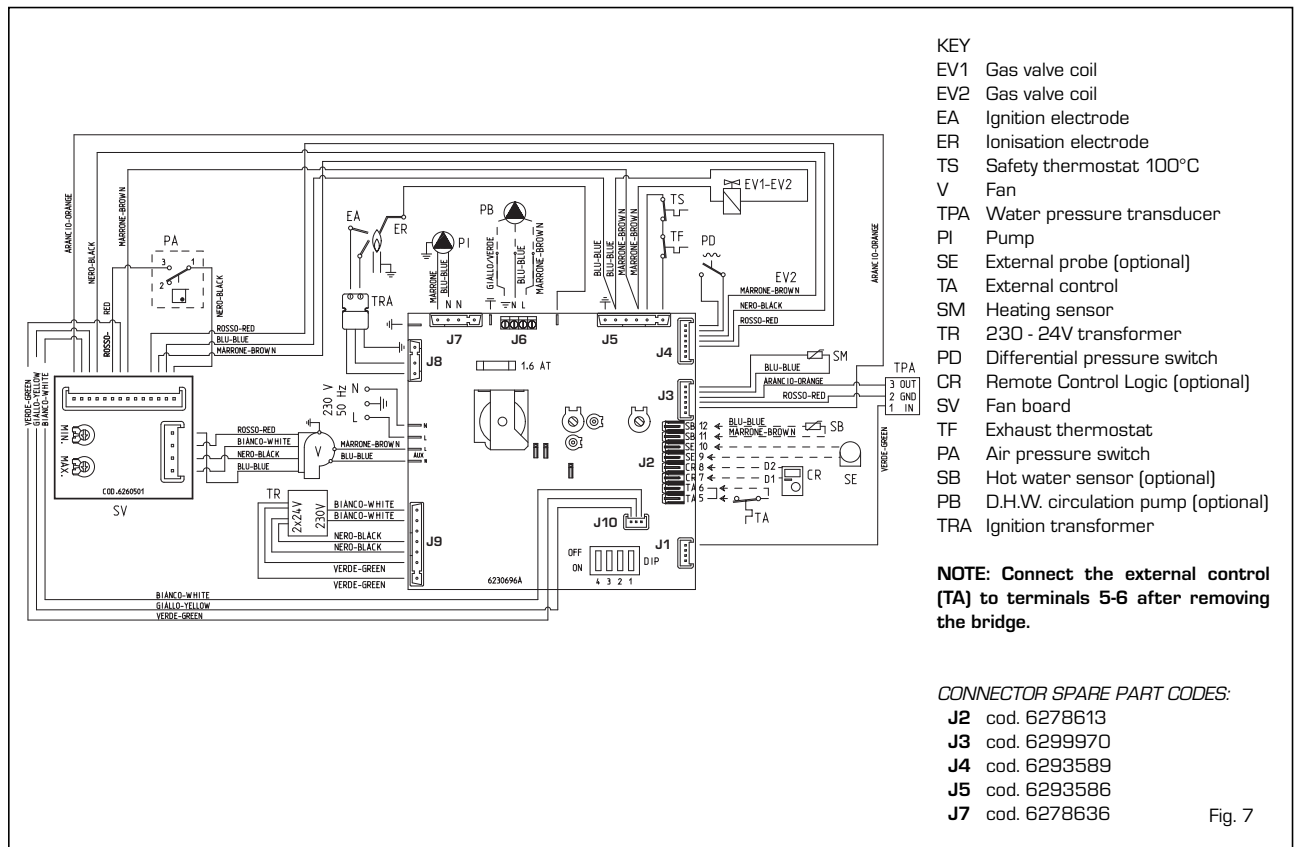
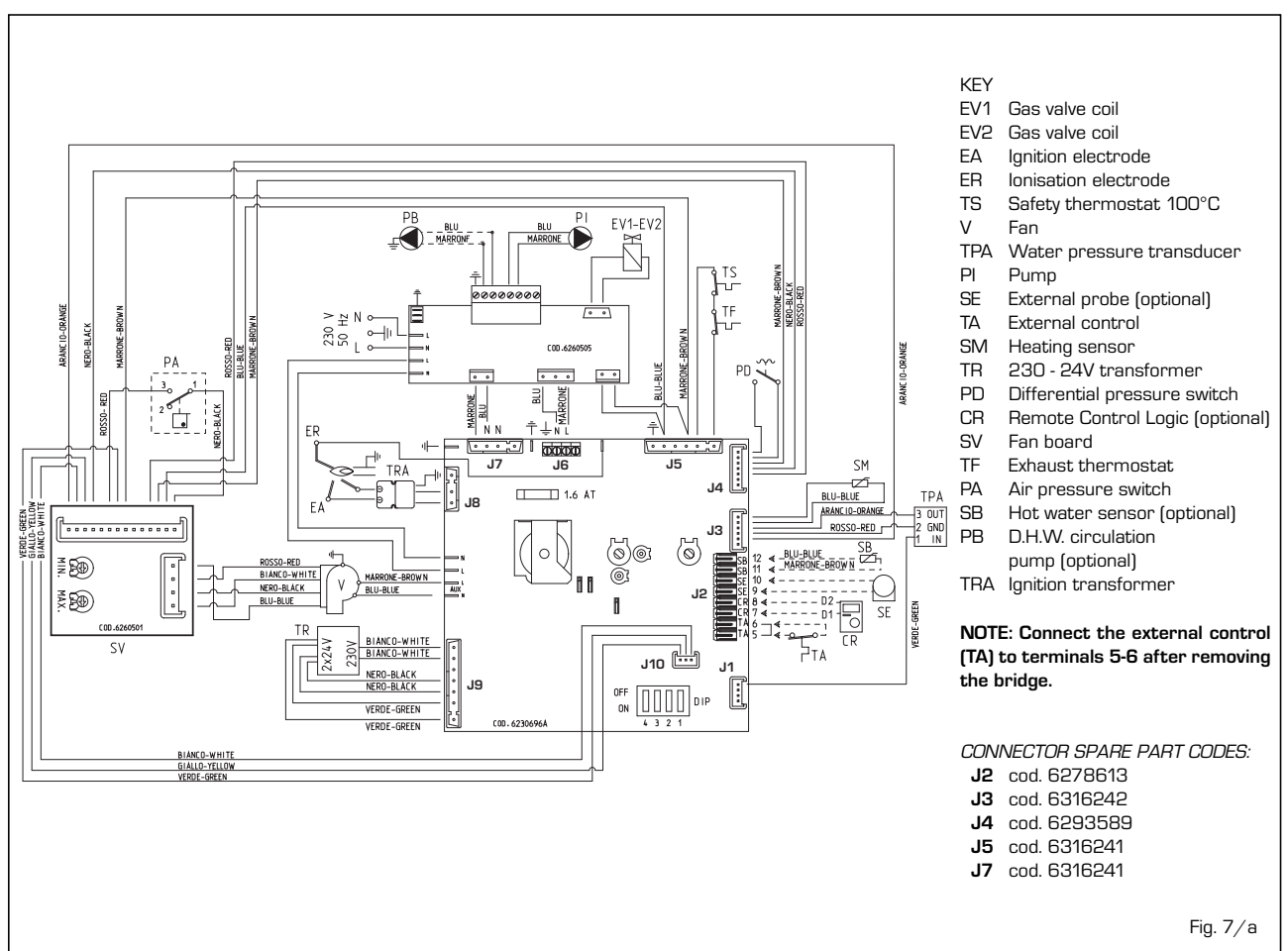

Fig. 6

2.6.4 Wiring diagram version PLANET DEWY 60 BFR (fig. 7)



2.6.5 Wiring diagram version PLANET DEWY 100 BFR (fig. 7/a)



2.6.6 The electric connection between the boiler and heater is downstream from the hydraulic separator (with TA)

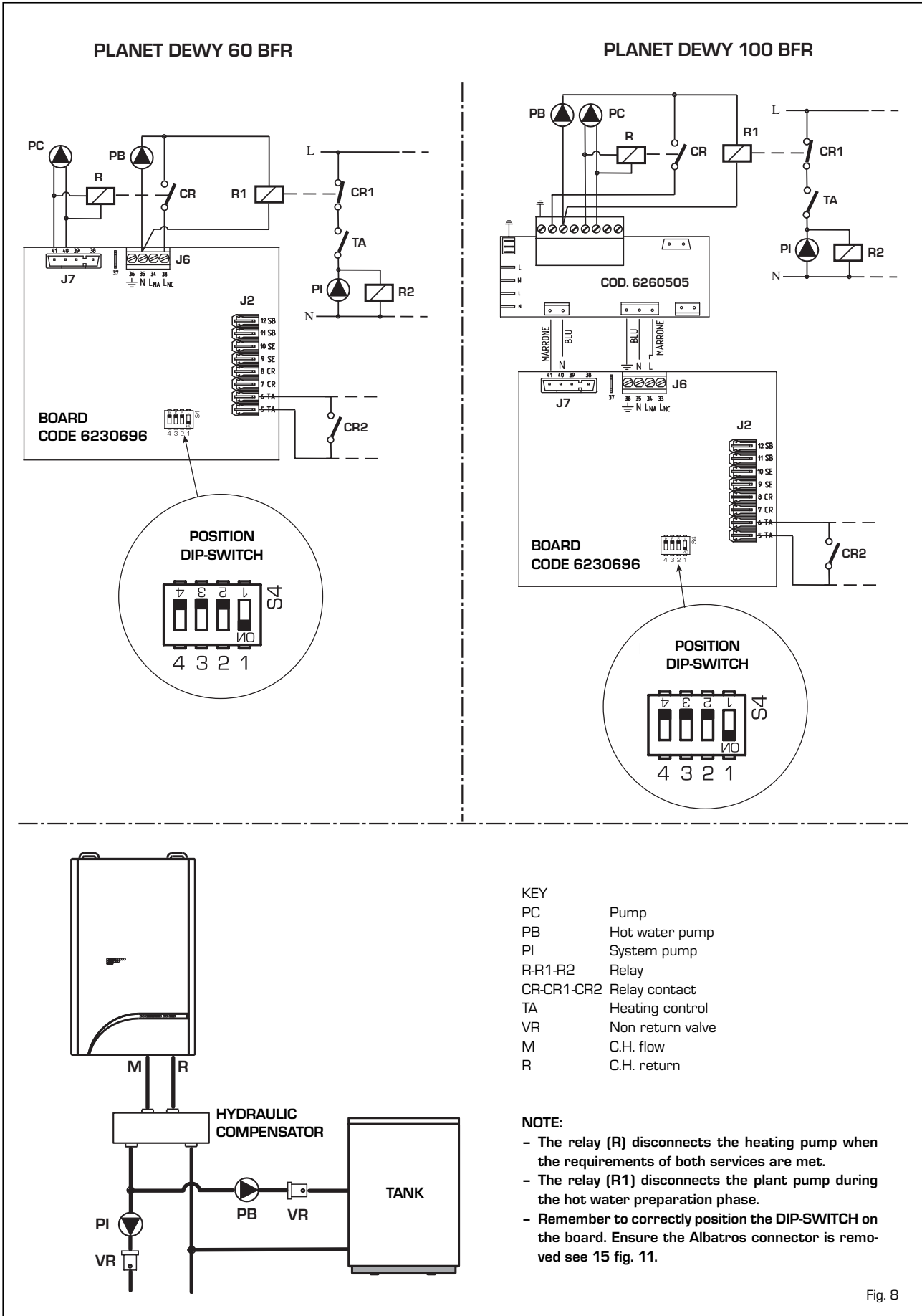
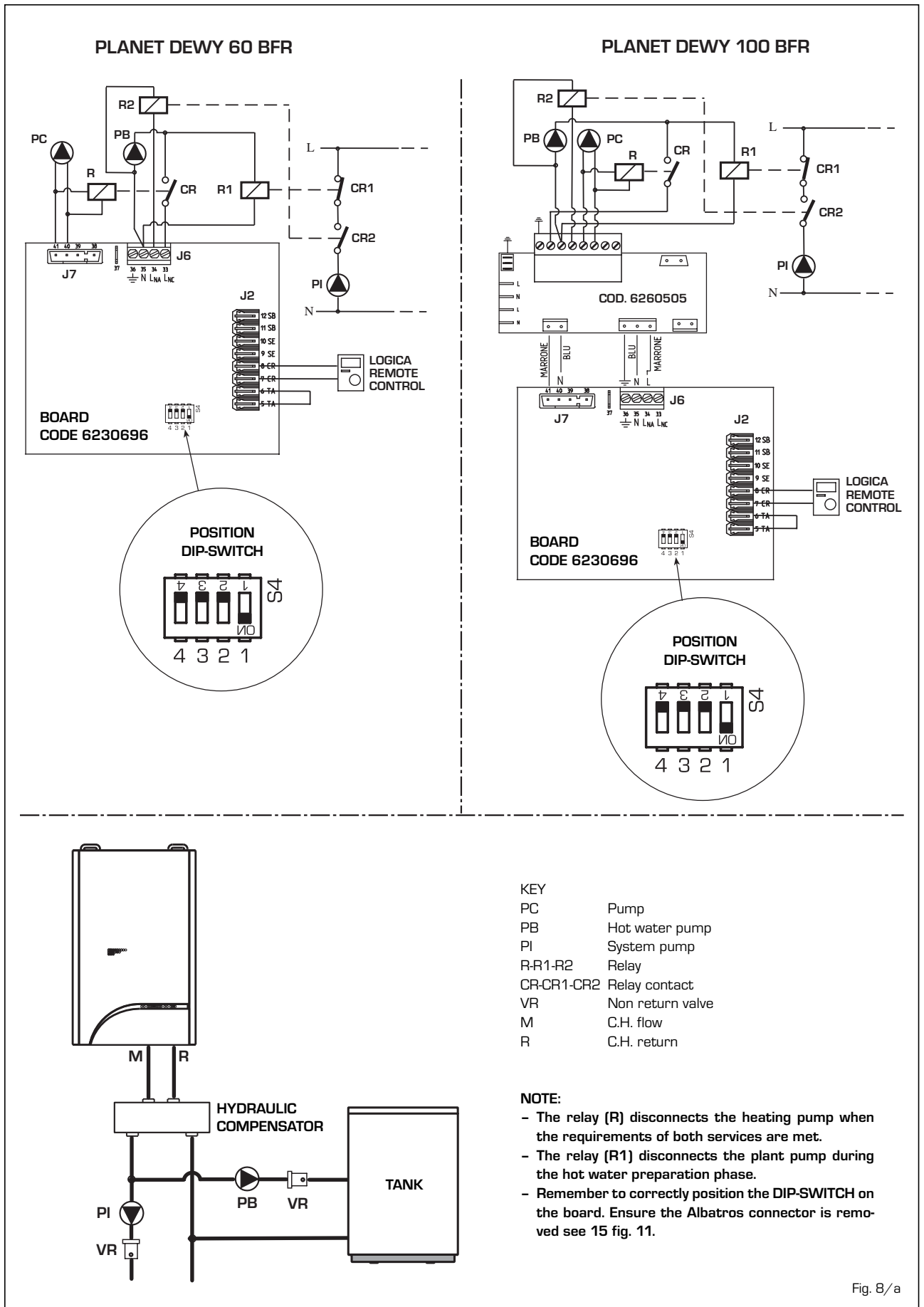

Fig. 8

2.6.7 The electric connection between the boiler and heater is downstream from the hydraulic separator (with LOGICA REMOTE CONTROL)



2.7 LOGICA REMOTE CONTROL USED WITH SINGLE BOILERS.

All the boiler's functions can be managed by a optional digital multifunctional device code 8092204 for the remote of the boiler itself and for regulating room climatic conditions with an operational reserve of 12 hours. The heating circuit is controlled by the room temperature sensor built-in the equipment or by the atmospheric conditions, with or without environmental inflow, if the boiler is connected to an external sensor. For operation of single boilers with Logica the Albatros connector must be removed, see 15 fig 11.

Characteristics:

- Ergonomic control unit divided according to function (control levels).
- Clear division of basic functions:
 - operating regime, correction of set value and presence button are directly accessible;
 - Different real current values are accessible through the "info" button;
 - other functions can be programmed after the cover has been opened;
 - special service level with protected access;
- Each setting or modification is displayed and confirmed.
- Tome setting (special line for changing BST/CET).
- Heating programme with max. 3 heating periods per day, individually selectable.

- Copy function for easy transfer of heating programme to the next or previous day.
- Holiday programme: the programme is interrupted for the holiday period and automatically restarted on returning home.
- Option to return the heating program to default values.
- Programming lock (child safety).

Functions:

- Delivery temperature control guided by the atmospheric conditions, taking into account the dynamics of the building.
- Delivery temperature control guided by atmospheric conditions with influence of ambient temperature.
- Ambient temperature control only.
- Adjustable influence of ambient temperature shift .
- Switch-on and switch-off optimisation.
- Rapid lowering.
- ECO functions (daily heating limiter, automatic summer/winter switch-over).
- Controllable maximum delivery temperature limit (specifically for floor plants).
- Limitation of increase in pre-set delivery temperature.
- Anti-freeze protection for buildings.
- Hourly programming of the tank unit temperature on two levels: comfort and reduced.
- Domestic hot water control with nominal value requirement and enable.
- Connection to room sensor or switching

of operating regime through the telephone system with external contact or through a window contact.

- Anti-bacterial.

2.7.1 Installation





The Logica control must be installed in a heated area. For installation, follow the assembly instructions inserted in the package. At this point, with the selector knob on , the installer can adjust the basic parameters settings according to the individual needs (point 2.7.2).

The radiators in the room that the Logica is fitted must not have thermostatic valves.





2.7.2 Installation settings

The settings for the basic operating parameters for individual needs are shown in the instruction leaflet supplied with the "Logica Remote Control" and in the section reserved for the user in this manual.

For further adjustments which can be carried out by the installer, the "Logica Remote Control" offers a level of service and parameterising which can only be accessed through a special combination of buttons.

To activate this level of service or parameterising press buttons  and  least 5 seconds. This will activate the parameterising level. Then use the same arrow buttons to select the individual input lines and adjust the values with  or .

HEATING CIRCUIT SETTINGS

Antifreeze protection "Pre-set ambient temperature value"		Heating takes place up to this pre-set value if the plant is activated in standby (e.g. holidays). In this way, the building antifreeze function is active, preventing an excessive lowering of the ambient.
Summer/Winter switch-over temperature		This parameter regulates the temperature of the automatic summer/winter switch-over.
Type of control: 0 = with ambient influence 1 = without ambient influence		This parameter de-activates the ambient influence and as a result all the optimisations and adaptations. If a valid external temperature is not transmitted, the controller switches to the pure ambient control guide variable.
Influence of ambient temperature		If the ambient controller is used only as a remote control (placed in the reference room and without an external sensor connected), the value must be set at 0 (zero). If the change in ambient temperature from the pre-set value remains high during the entire day, the influence must be increased. If the ambient temperature is around the pre-set value (control oscillation), the influence must be reduced. Note: If the ambient temperature influence constant is set at 0, the adaptation of the heating curve is deactivated. In this case, parameter 57 will have no effect at all.

Maximum limit of delivery temperature	55	The delivery temperature is limited to the maximum set value.
Variation of the maximum speed of the delivery temperature	56	The increase per minute of the prescribed delivery temperature value sent in °C is limited to the imposed value.
Activation of adaptation	57	With the activation of the adaptation, the pre-set value transmitted to the boiler regulator is adapted to the effective heat need. The adaptation functions with both the atmospheric guide with ambient influence and with pure ambient control. If the "Logica Remote Control" is set as a remote control only, the adaptation must be is deactivated.
Optimisation of switch-on time	58	If the switch-on time optimisation is active, the "Logica Remote Control" modifies the heating gradient until it finds the optimum heating point 0 = off 1 = on
Heating gradient	59	The "Logica Remote Control" selects the switch-on time such that the set value has more or less been reached at the start of the usage time. The more severe the night-time cooling, the earlier the heating time starts. Example: Current ambient temperature 18.5°C Nominal ambient temperature 20°C Heating gradient 30 min/K Presetting of switch-on time: 1.5 K x 30 min/K = 45 minutes 00 means that the switch-o time has not been pre-set (function disabled).
Presetting switch-off time (00 = off)	60	If the switch-off time optimisation is active (value > 0), the "Logica Remote Control" modifies the pre-set time until it finds the optimum switch-off time..

DOMESTIC HOT WATER SETTINGS

Reduced domestic hot water pre-set value	61	The reduced pre-set value of the temperature of the domestic hot water allow the required water temperature to be obtained outside the programmed usage times (daily programme 8).
Domestic hot water load	62	0 = 24 hours/ day - Hot water is always available at the temperature set with user parameter n°3. 1 = standard - Hot water according to the daily heating programme. In the comfort areas of heating the temperature of the boiler unit is regulated to the value set with user parameter n° 3. In the reduced areas of heating the temperature of the boiler unit is regulated to the value set with parameter n° 61 of the service level. 2 = service disconnected 3 = second daily programme (8) - Every day of the week the temperature of the hot water is set according to programme 8. In this case there is a single programming for all the days of the week and three time zones are available. In the time spans set the temperature of the boiler unit is regulated according to that set in parameter n°3. In the remaining hours the boiler unit is controlled to the temperature set with parameter n° 61 the of service level.

SERVICE VALUES

Final user level 2 programming block	63	This block (1) can be activated to display all the parameters without modifying them. Pressing buttons \square or \oplus displays "OFF". WARNING: The activation block can be deactivated temporarily by pressing buttons \blacktriangle and \oplus simultaneously; a confirmation sign appears on the display. At this point press simultaneously the buttons \blacktriangle and \blacktriangledown for at least 5 seconds. To permanently remove the activation block, set parameter 63 on 0.
---	-----------	---

Input function terminal 3-4

64

The freely programmable input (terminals 3-4) allows three different functions to be activated. The parameter has the following significance:

- 1** = If an external sensor is connected, the display will show the temperature of the external sensor (_ _ = no sensor connected, function disabled).
- 2** = With an external contact, it is possible to switch-over to "reduced pre-set value of the ambient temperature".
- 3** = With an external contact, it is possible to switch-over to "reduced pre-set value of the antifreeze ambient temperature" (short circuit 0 0 0 or interruption _ _ _). The display shows the current status of the external contact.

Operating mode of external contact

65

If the entrance (terminals 3 and 4 of the base) is connected to a zero potential external contact (parameter 64 = 2 or 3), the operating mode of the contact can be determined (remote telephone switch or window contact). The operating mode specifies the status of the contact in which the required function is active.

Display: Operating mode closed (short circuit) 0 0 0
Operating mode open (interruption) _ _ _

External and ambient sensor influence

66

Determines the mix ratio between the internal and external ambient sensor when parameter 64 = 1.

- 0 %** = internal sensor only active (0% external - 100% internal)
- 50 %** = mean value of external + internal sensor
- 100 %** = external sensor only active

The set mix is used for ambient control and display.
If the external sensor is short circuited or interrupted, the operation continues with the internal sensor.

Anti-bacterial function (with storage capacity boiler unit)

69

This function allows the hot water to be brought to a high temperature once a week in order to eliminate eventual pathogenic agents. It is active every Monday for a maximum duration of 2.5 hours at a delivery temperature of 65°C.

0 = not active 1 = active

2.7.3 Gradient of the characteristic heating curve (fig. 9)

The gradient of the characteristic heating curve is imposed on the current value "15" of LOGICA REMOTE CONTROL.
Increasing the gradient as shown in the drawing of fig. 9, the delivery temperature increases in correspondence to the outside temperature.

2.8 EXTERNAL TEMPERATURE SENSOR

The LOGICA REMOTE CONTROL can be connected to an external temperature sensor available as an optional extra (code 8094100). This configuration ensures and maintains the required temperature constant in the room. The ambient temperature is, in fact, indicated and evaluated as the calculated mean of the value measured inside and outside the dwelling. For installation, follow the assembly instructions inserted in the package.

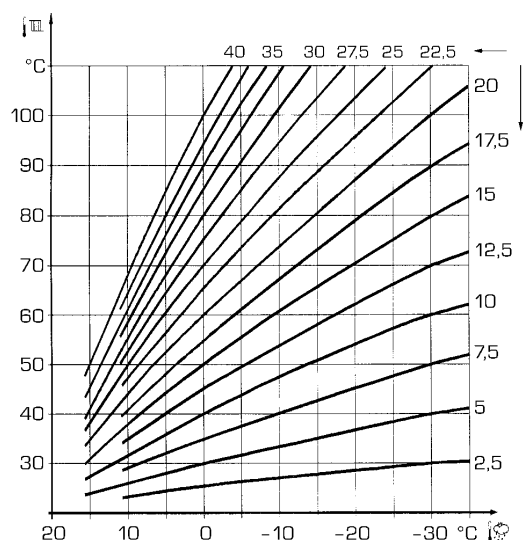

Example: Choosing a gradient of 15 with an outside temperature of -10°C we shall have a delivery temperature of 60°C.

Fig. 9

3 CHARACTERISTICS

3.1 ELECTRONIC BOARD

Built according to Low Voltage directive 2006/95/CEE and powered at 230 Volt, via a transformer it sends 24 Volt power to the following components: gas valve, safety thermostat, heating probe, external temperature probe (optional), water pressure transducer, air pressure switch, external controls or "Remote Control Logic". An automatic and continual modulation system permits the boiler to adjust power to the various system or user needs. Electronic components are guaranteed to operate in a temperature range from 0 to +60°C.

3.1.1 Malfunctions (fig. 10)

Boiler malfunctions or failures can be indicated by a flashing temperature LED as shown in fig 10.

3.1.2 Devices (fig. 11)

The electronic board is equipped with the following devices:

- "HEATING POWER" TRIMMER (10 fig. 11)
Adjusts maximum heating power. To increase the value, rotate the trimmer

clockwise, to reduce it, rotate the trimmer counter-clockwise.

- "IGNITION POWER" TRIMMER (6 fig. 11)
Trimmer to vary the gas valve ignition pressure level (STEP). According to the type of gas the boiler is designed for, the trimmer must be adjusted to achieve a burner pressure of approximately 6.5 mm H2O for methane gas and 9.5 mm H2O for propane gas (G31). To increase pressure, rotate the trimmer clockwise, to reduce it, rotate the trimmer counter-clockwise. The slow ignition pressure level can be set during the first five seconds after the burner is lit.
After setting the ignition pressure level (STEP) according to the type of gas, make sure that the heating gas pressure is still the previously set value.

- "ANN. RIT." CONNECTOR (5 fig. 11)
The electronic board is programmed, during heating, with a technical burner delay of about 90 seconds that is performed both at cold start and subsequent ignitions. This is to prevent rapid ignitions and shutdowns that could, in particular, occur in systems with high load losses. Each time the boiler restarts, after the slow ignition, for about 1 minute it will

run at minimum modulation pressure before moving to the set heating pressure. The addition of a bridge will cancel both the programmed technical delay and the minimum pressure operating period at ignition. In this case, the time between shutdown and the next ignition will depend on a 5°C differential detected by the heating probe (SM).

- DIP SWITCH (13 fig. 11)
For correct module operations, the dip switches must be positioned as indicated below:

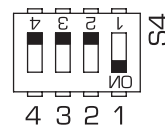

- "Modureg Sel." connector (14 fig. 11)
The bridge must always be connected.
- "Albatros" connector (15 fig. 11)
The bridge is removed for operation of single boilers with the Logica and connected for operation of multiple boilers in cascade with the RVA controller.

WARNING: All the above operations must be performed by authorised personnel, otherwise the warranty will be invalidated.

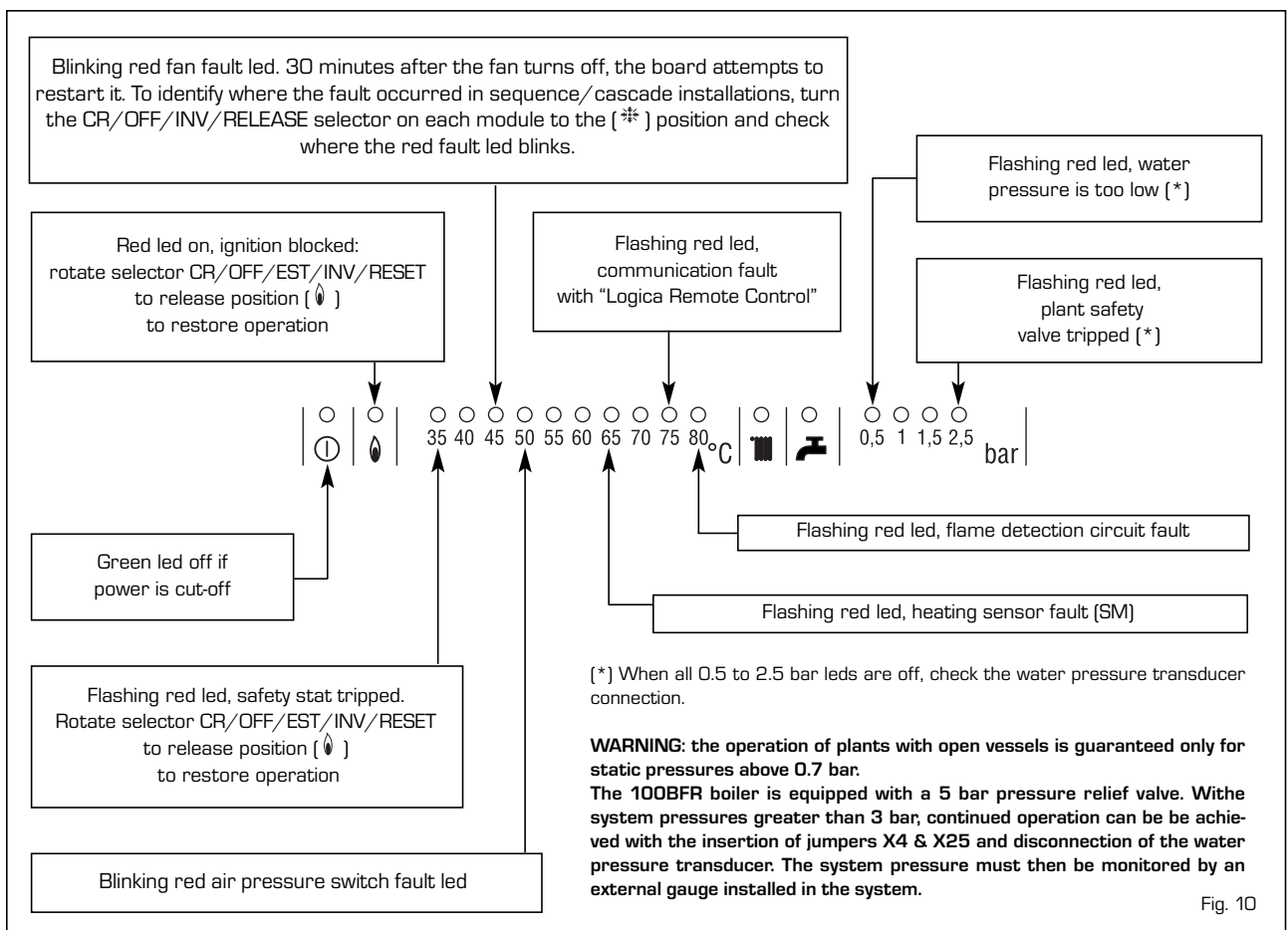

Fig. 10

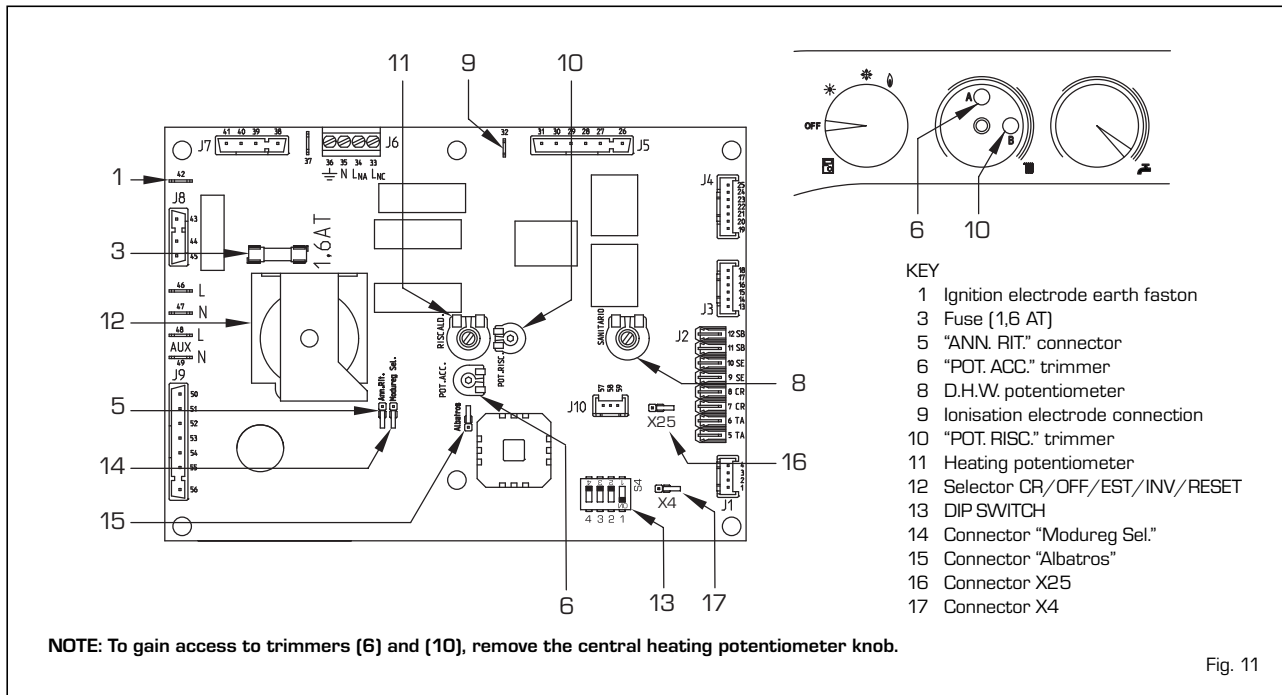

Fig. 11

3.2 TEMPERATURE PROBE AND WATER PRESSURE TRANSDUCER

Frost protection is controlled by the NTC heating sensor that activates when the water temperature reaches 6°C. Tables 1 - 1/a include the resistance values (Ω) that are obtained on the probe (SM) when the temperature changes and those on the transducer (TPA) when pressure changes.

The boiler will not work if the heating probe (SM) is open circuit or disconnected.

TABLE 1 (Sensors)

Temperature [°C]	Resistance [Ω]
20	12.090
30	8.313
40	5.828
50	4.161
60	3.021
70	2.229
80	1.669

TABLE 1/a (Transducer)

Pressure (bar)	Resistance [Ω]	
	mín	máx
0	297	320
0,5	260	269
1	222	228
1,5	195	200
2	167	173
2,5	137	143
3	108	113
3,5	90	94

3.3 ELECTRONIC IGNITION

Ignition and flame detection is controlled by two electrodes located on the burner. These guarantee maximum safety with interven-

tion times, for accidental switching off or gas failure, of within one second.

3.3.1 Operating cycle

Rotate the selector to summer or winter and check the green led (Ⓛ) to make sure power is on. The burner should ignite within max. 10 seconds. An ignition failure will cause the "Ignition Lockout" indicator (fig 10) to illuminate. This may be due to the following:

- **Ignition electrode does not spark**
Gas is being supplied to the boiler and, after 10 sec., the lockout led turns on. This may be due a faulty or disconnected spark generator, faulty or disconnected ignition electrode.
- **No flame detection**
At ignition, the electrode continues to spark even though the burner is on. After

10 sec. it stops sparking, the burner turns off and the block led turns on.

This may be due to a faulty, disconnected or damaged ionisation electrode, wrong polarity (live and neutral reversed).

The boiler should resume automatically after a power failure.

3.4 AIR PRESSURE SWITCH

The air pressure switch is not adjustable. Its value is shown on the air pressure switch.

3.5 SYSTEM AVAILABLE HEAD (fig. 12)

The residual head of the boiler supply and return lines varies according to capacity, as shown in the diagram of fig. 12.

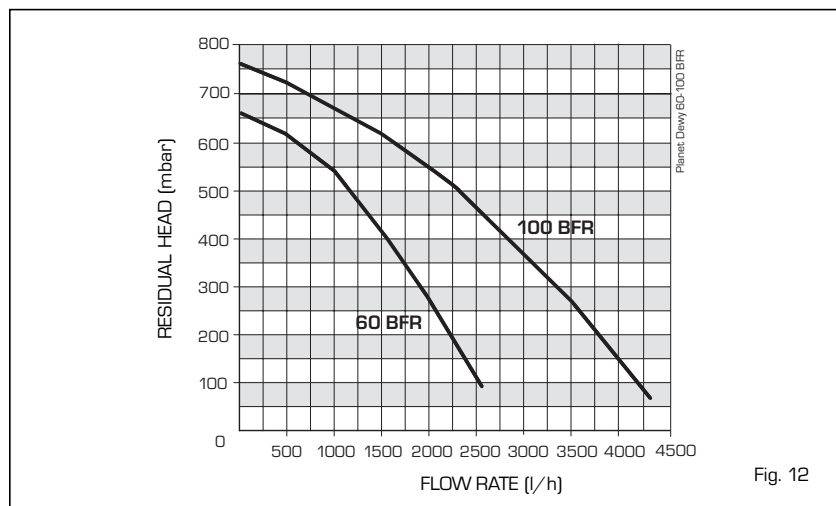
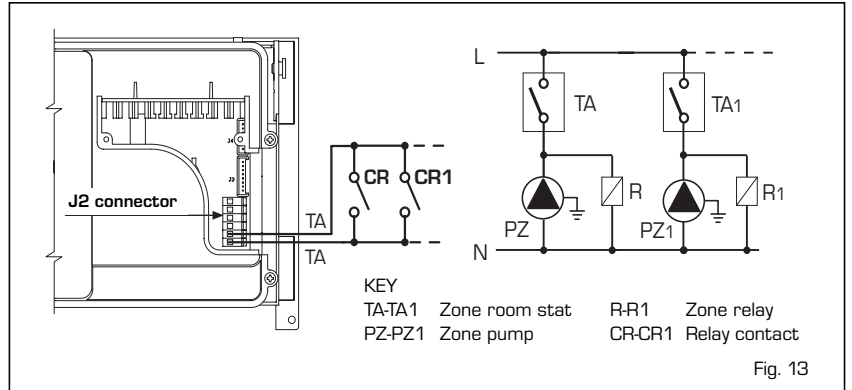

Fig. 12

3.6 MAINS ELECTRICITY CONNECTION (fig. 13)

Use a separate electrical line where the room thermostats with relevant area pumps must be connected.
Switch or relay contacts must be connected to the electronic board connector (J2) after removing the link (fig. 13).



3.7 "PLANET DEWY 60 BFR" WITH OPTIONAL KIT 8101530 (shown connected to a hot water cylinder)

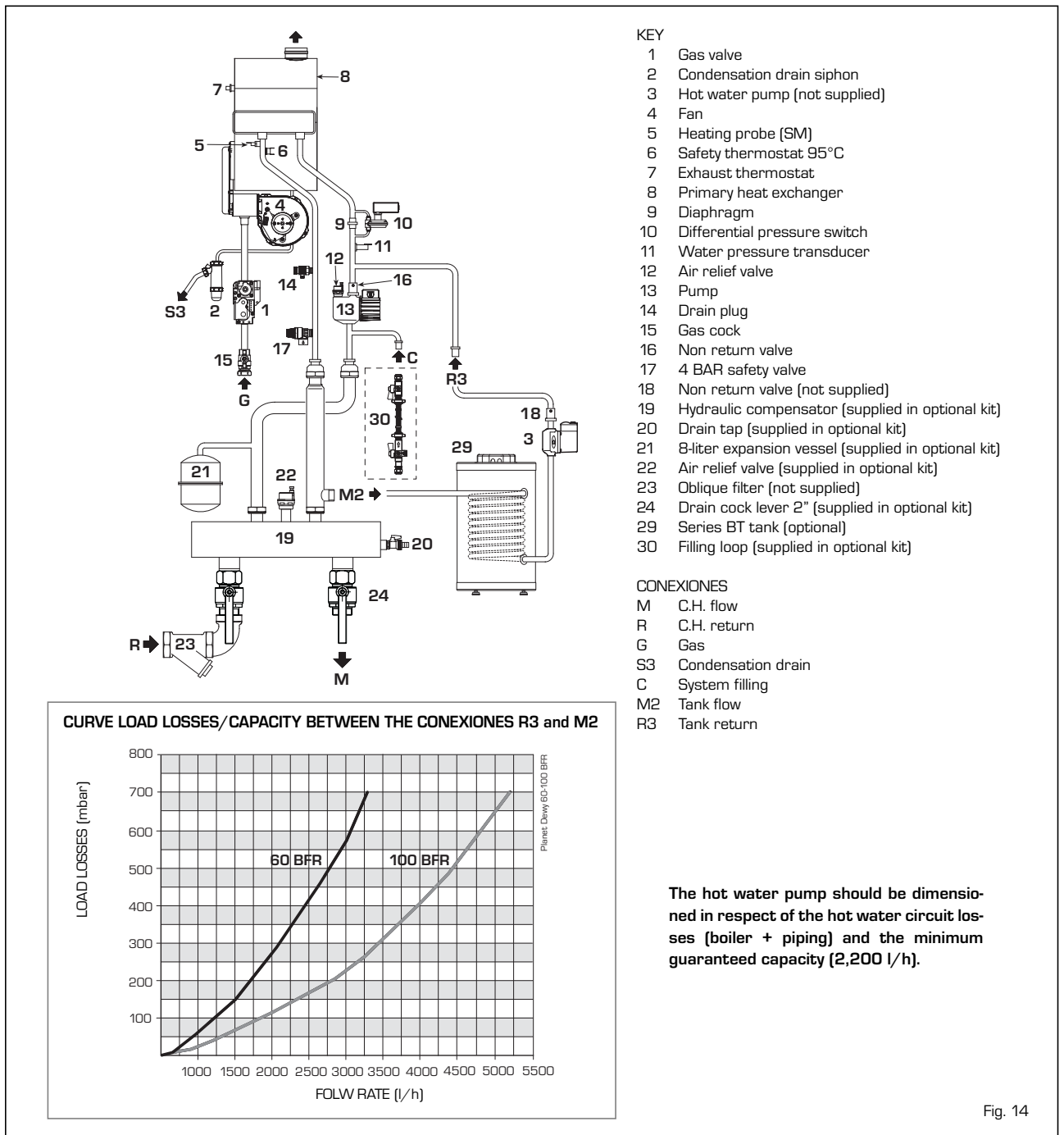

3.8 "PLANET DEWY 100 BFR" WITH OPTIONAL KIT 8101531 (shown connected to a hot water cylinder)

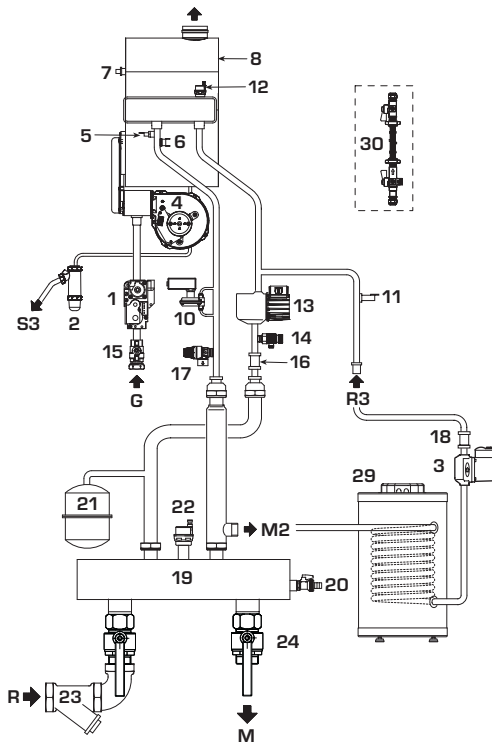

- KEY
- 1 Gas valve
 - 2 Condensation drain siphon
 - 3 Hot water pump (not supplied)
 - 4 Fan
 - 5 Heating probe (SM)
 - 6 Safety thermostat 95°C
 - 7 Exhaust thermostat
 - 8 Primary heat exchanger
 - 10 Differential pressure switch
 - 11 Water pressure transducer
 - 12 Air relief valve
 - 13 Pump
 - 14 Drain plug
 - 15 Gas cock
 - 16 Non return valve
 - 17 5 BAR safety valve
 - 18 Non return valve (not supplied)
 - 19 Hydraulic compensator (supplied in optional kit)
 - 20 Drain tap (supplied in optional kit)
 - 21 8-liter expansion vessel (supplied in optional kit)
 - 22 Air relief valve (supplied in optional kit)
 - 23 Oblique filter (not supplied)
 - 24 Drain cock lever 2" (supplied in optional kit)
 - 29 Series BT tank (optional)
 - 30 Filling loop (supplied in optional kit)

- CONEXIONES
- M C.H. flow
 - R C.H. return
 - G Gas
 - S3 Condensation drain
 - M2 Tank flow
 - R3 Tank return

CURVE LOAD LOSSES/CAPACITY BETWEEN THE CONEXIONES R3 and M2

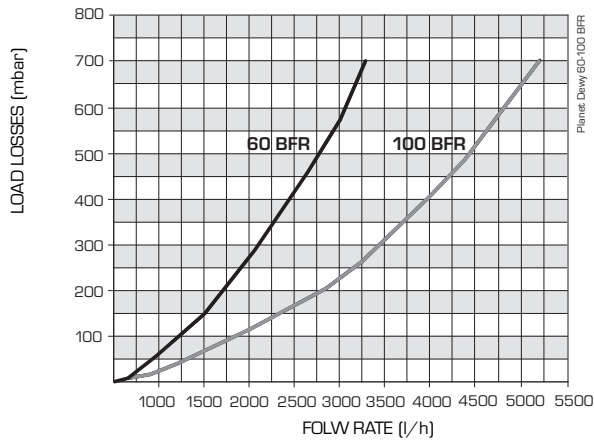

The hot water pump should be dimensioned in respect of the hot water circuit losses (boiler + piping) and the minimum guaranteed capacity (3,800 l/h).

Fig. 15

4 USE, MAINTENANCE (including BENCHMARK), and COMMISSIONING

4.1 BOILER CALIBRATION (fig. 16)

GAS CONVERSION

- Close the gas cock.
- Replace the injector (pos. 30) and the relevant gasket (pos. 45).
- Cut the specified resistance on the fan control board.
- Test for soundness all the gas connections using soapy water or appropriate products.
- DO NOT USE NAKED FLAMES.
- Stick onto the casing panel the plate showing the relevant feeding gas.
- Proceed with air and gas calibration as described below.

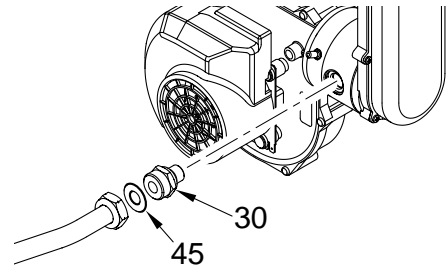

Single modules are calibrated in heating position.

"Δp air" ADJUSTMENT

To measure "Δp air" simply connect the differential pressure gauge, equipped with a decimal scale in mm H₂O or Pascal, to the positive and negative sockets on the air pressure switch (Drawing 1).

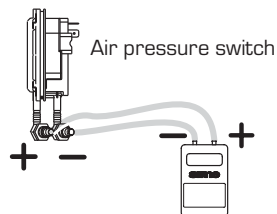

Operating sequence:

- 1) Rotate the module heating power adjustment trimmer clockwise to the limit (B - Drawing 2); fan on maximum.
- 2) Find the "max Δp air" values in the table, using the fan board "MAX" trimmer (Drawing 3);

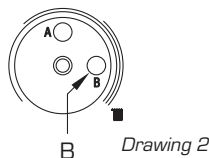

Max. Δp air (mm H₂O)

Single module	60 kW	100 kW
G20	60.0 ±2	65.0 ±2
G31	63.0 ±2	70.0 ±2

- 3) Rotate the module heating power adjustment trimmer counter-clockwise to the limit (B - Drawing 2); fan on minimum.

- 4) Find the "min Δp air" values in the table, using the fan board "MIN" trimmer (Drawing 3).

Min. Δp air (mm H₂O)

Single module	60 kW	100 kW
G20	5.8 ±0,2	6.5 ±0,2
G31	10.9 ±0,2	7.0 ±0,2

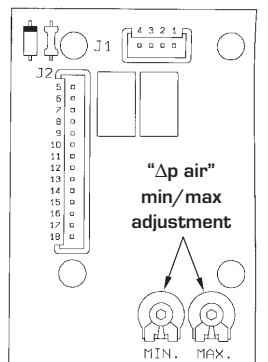

"Δp air-gas" ADJUSTMENT

To measure "Δp air-gas" simply connect the positive socket on the differential pressure gauge to the downstream pressure fixture and the negative socket to the air pressure switch (Drawing 4). Gas pressure is always adjusted with the fan on minimum.

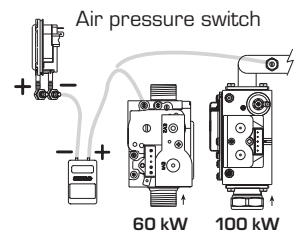

Operating sequence:

- 1) Rotate the module heating power adjustment trimmer counter-clockwise to the limit (B - Drawing 5); fan on minimum.
- 2) Completely unscrew the valve gas shutter (1 - Drawing 6).

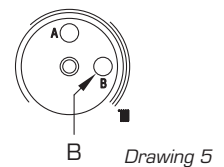

- 3) Use the gas valve OFF-SET adjustment screw (2 - Drawing 6) and find the "Δp air-gas" value in the table.

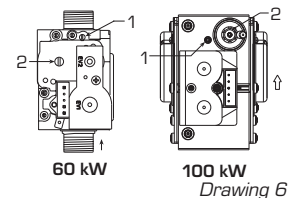

- 4) Use the shutter (1 - Drawing 6) and find the "Δp air-gas" value in the table:

Shutter open (mm H₂O)

Single module	60 kW	100 kW
G20	4.2 ±0,1	5.2 ±0,1
G31	9.2 ±0,1	6.5 ±0,1

Adjusted shutter (mm H₂O)

Single module	60 kW	100 kW
G20	3.8 ±0,1	4.3 ±0,1
G31	8.7 ±0,1	4.6 ±0,1

After calibrations, check the CO₂ values with a combustion analyser: If they deviate more than 0.2 from the table values, the following corrections must be made:

	CO ₂	
	Methane (G20)	Propane (G31)
"MIN" Power	9.0 ±0,2	10.0 ±0,2
"MAX" Power	9.0 ±0,2	10.0 ±0,2

- To correct CO₂ to the "MIN" power, use the OFF-SET screw (2 - Drawing 6).
- To correct CO₂ to the "MAX" power, use the shutter (1 - Drawing 6).

CO / CO₂ RATIO

CO ₂ %		CO ppm	
		100	400
NG 9%		0,0011	0,0044
LPG 10%		0,0010	0,0040

Fig. 16

4.2 GAS VALVE (fig. 17)

The boiler "60 BFR" is equipped standard with the SIT 848 SIGMA gas valve. The boiler "100 BFR" is equipped standard with the DUNGS GB-GD 057 gas valve (fig. 17).

4.3 SHELL REMOVAL (fig. 18)

For easy boiler maintenance the shell can be completely removed by following these instructions (fig. 18):

- Remove the two screws from the top of the front panel
- Pull the front panel forward to unhook it from the pegs on the sides.
- Unscrew the two screws that secure the instrument panel to the sides
- Unscrew the four screws that secure the side to the instrument panel support.
- Push the sides upwards sliding them off the frame hooks.

4.4 CLEANING AND MAINTENANCE

General (fig. 19)

PLEASE NOTE: During routine servicing, and after any maintenance or change of part of the combustion circuit, the following must be checked:

- The integrity of the flue system, and the flue seals.
- The integrity of the combustion circuit and the relevant seals.
- The combustion performance, as described in the commissioning section.

The boiler should be serviced at regular intervals, at least annually, by a qualified engineer. During maintenance operations the authorised technician must check that the condensate trap is full of water (this is of particular importance if the boiler has been out of use for some time). Filling is done via the special opening (fig. 19).

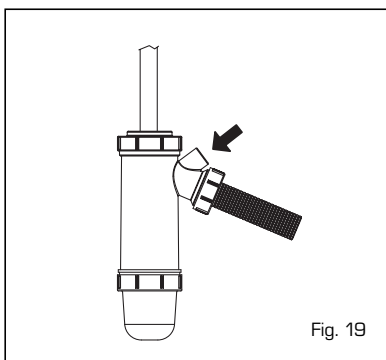

Fig. 19

4.4.1 Chimney sweep function (fig. 20)

To check single module combustion, rotate the selector to position (OFF) and hold, until the yellow led () starts to blink (fig. 20). At this time the module will start to heat at

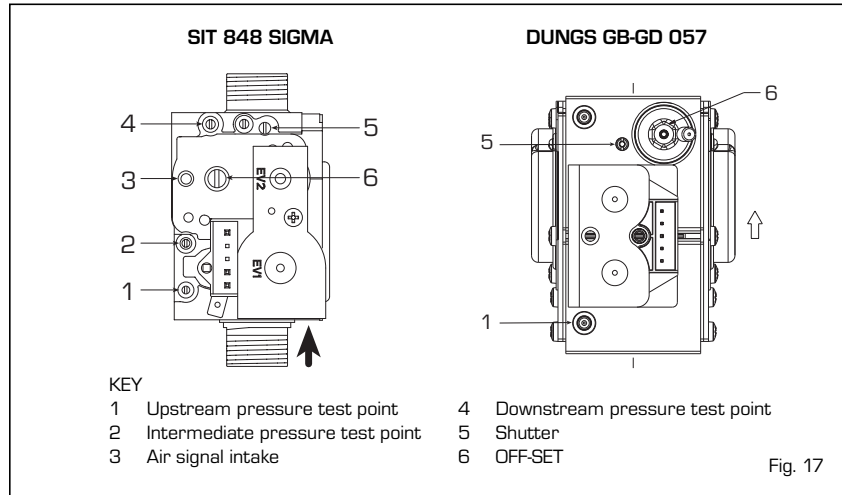

Fig. 17

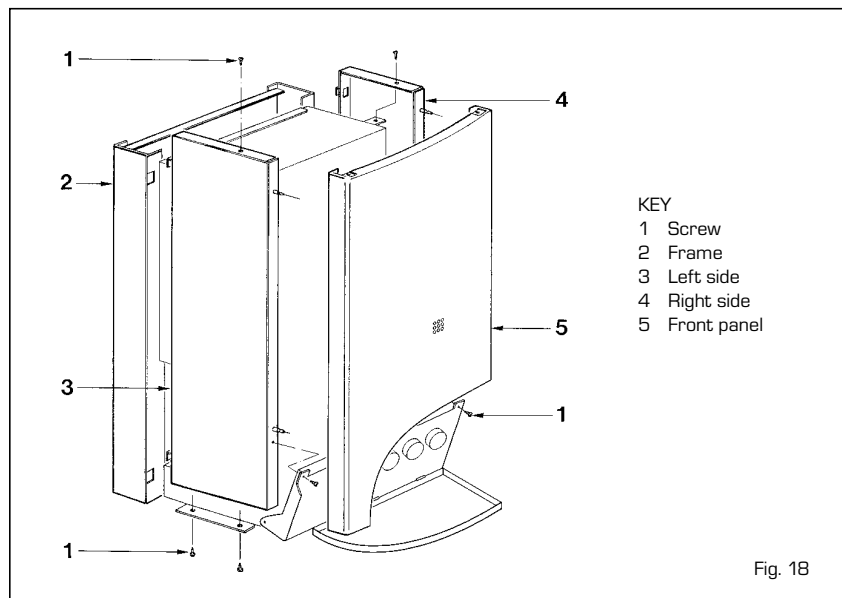

Fig. 18

maximum power and turn off at 80°C, restarting at 70°C.

Before starting the chimney sweep function, make sure the system valves are open. After checking combustion, turn OFF the module by rotating the selector to

(OFF); return the selector to the required function.

ATTENTION: After about 15 minutes the chimney sweep function automatically deactivates.

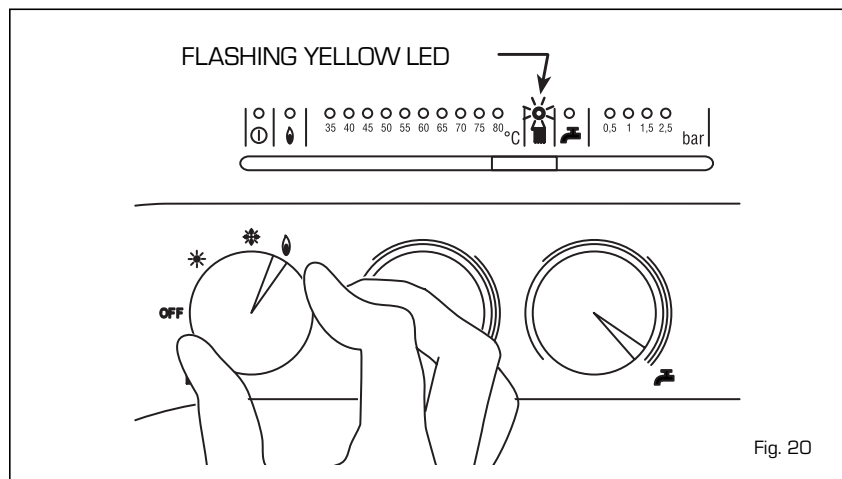

Fig. 20

4.5 COMMISSIONING INSTRUCTIONS

4.5.1 General (fig. 21)

Please note: the combustion for this appliance has been checked, adjusted and preset at the factory for operation on the gas type defined on the appliance data plate. However, it is advisable to check for correct combustion as described in fig 21, having first checked the following.

- That the boiler has been installed in accordance with these instructions.
- The integrity of the flue system and the flue seals.
- The integrity of the boiler combustion circuit.

Proceed to put the boiler into operation as follows:

Check the operational (working) gas inlet pressure

Set up the boiler(s) to operate at maximum rate as described in 4.3.1 (chimney sweep)

With the boiler operating in the maximum rate condition check that the operational (working) gas pressure at the inlet gas pressure test point (see fig. 17 item 1) complies with the requirements of table 1.3.

Ensure that this inlet pressure can be obtained with all other gas appliances in the property working.

Competence to carry out the check of combustion performance

Please note: BS 6798: 2009 Specification for installation and maintenance of gas-fired boilers of rated input not exceeding 70kW net advises that:

- The person carrying out a combustion measurement should have been assessed as competent in the use of a flue gas analyser and the interpretation of the

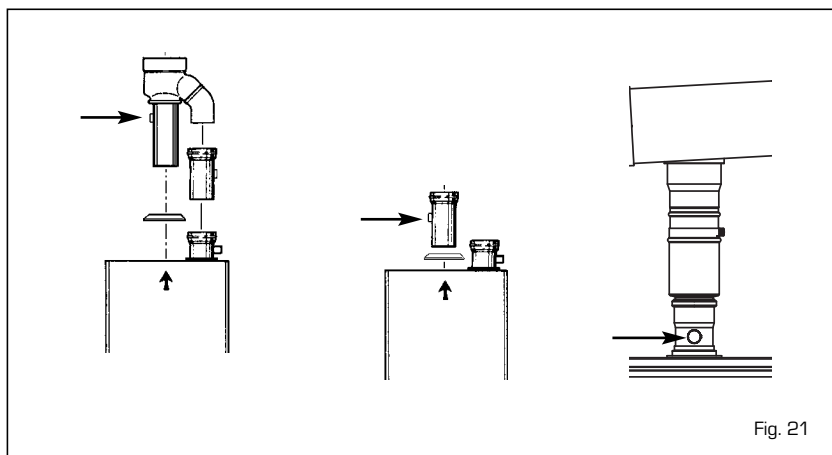

results.

- The flue gas analyser used should be one meeting the requirements of BS7927 or BS-EN50379-3 and be calibrated in accordance with the analyser manufacturers requirements, and
- Competence can be demonstrated by satisfactory completion of the CPA1 ACS assessment, which covers the use of electronic portable gas analysers in accordance with BS 7967, parts 1 to 4.

Combustion check

Connect the flue gas analyser to the flue gas sampling point as shown in the diagram.

Procedure for checking the combustion

Turn the heating control knob to maximum and then remove it.

Locate adjuster "B" (Fig 16 drawing 2) and note its position, after test return to this position, boilers in cascade will normally have adjuster "B" set to maximum.

Turn adjuster "B" to minimum (anti-clockwise) Light the boiler and record the measurements from the flue gas analyser = minimum output.

Turn the adjuster "B" to maximum (clockwise). Record the measurements from the flue gas analyser = maximum output.

Compare the results to the following:

CO less than 200ppm

CO₂ between 8.7% and 9.3% natural gas,

and 9.7% and 10.3% LPG

Ratio less than 0.004

If the combustion reading is greater than the acceptable value AND the integrity of the complete flue system and combustion circuit seals have been verified, and the gas inlet pressure have been verified proceed as shown in 4.1

Any adjustments should be done in small steps and adjustments of no more than 1/8th of a turn should be made, waiting at least 1 minute between adjustments to allow the settings to stabilise. Using the CO₂ reading, adjustments should be made to the "OFF-SET" screw (2 drawing 6) if it is incorrect at the minimum output, or to the "SHUTTER" (1 drawing 6) if it incorrect at the maximum output.

If an acceptable setting level cannot be achieved, re-confirm that the integrity of the flue system, combustion circuit and working gas supply pressure. If required contact Sime Ltd for further assistance.

Service Record

It is recommended that your heating system is serviced regularly and that the appropriate Service Interval Record is completed. This is also a condition of any extended warranty offered.

Service Provider

Before completing the appropriate Service Record below, please ensure you have carried out the service as described in the manufacturer's instructions.

Always use the manufacturer's specified spare part when replacing controls.

Service 1 Date: _____
Engineer Name: _____
Company Name: _____
Telephone No. _____
Gas Safe Register No. _____
Comments: _____
Signature: _____

Service 2 Date: _____
Engineer Name: _____
Company Name: _____
Telephone No. _____
Gas Safe Register No. _____
Comments: _____
Signature: _____

Service 3 Date: _____
Engineer Name: _____
Company Name: _____
Telephone No. _____
Gas Safe Register No. _____
Comments: _____
Signature: _____

Service 4 Date: _____
Engineer Name: _____
Company Name: _____
Telephone No. _____
Gas Safe Register No. _____
Comments: _____
Signature: _____

Service 5 Date: _____
Engineer Name: _____
Company Name: _____
Telephone No. _____
Gas Safe Register No. _____
Comments: _____
Signature: _____

Service 6 Date: _____
Engineer Name: _____
Company Name: _____
Telephone No. _____
Operative ID No. _____
Comments: _____
Signature: _____

Service 7 Date: _____
Engineer Name: _____
Company Name: _____
Telephone No. _____
Gas Safe Register No. _____
Comments: _____
Signature: _____

Service 8 Date: _____
Engineer Name: _____
Company Name: _____
Telephone No. _____
Gas Safe Register No. _____
Comments: _____
Signature: _____

Service 9 Date: _____
Engineer Name: _____
Company Name: _____
Telephone No. _____
Gas Safe Register No. _____
Comments: _____
Signature: _____

Service 10 Date: _____
Engineer Name: _____
Company Name: _____
Telephone No. _____
Gas Safe Register No. _____
Comments: _____
Signature: _____

Commissioning Checklist for BFR Boilers

This checklist is for guidance only, and is not a full installation safety check

Address _____ Engineer _____

	1	2	3	4	5	6
Satisfactory visual check of flue Y/N						
Flue within allowable length and correctly terminated Y/N						
Confirm Tightness of installation pipework downstream of Isolating valve using leak detection fluid Y/N						
Check tightness of all valves Y/N						
Carryout ignition test of boiler with gas isolated to ensure boiler fails safe Y/N						
Turn on gas supply to boiler and isolate main burner(disconnect gas valve) and ensure boiler goes to lockout Y/N						
Reset boiler lockout and retry, ensuring boiler again locks out Y/N						
Reconnect gas valve, reset boiler lockout, and ensure boiler lights and is stable Y/N						
Test safety devices Y/N						
Differential flow switch-disconnect - the pump and fan should operate but no ignition or lockout Y/N						
Smoke stat - Disconnect - the boiler should attempt to light and fail as lockout Y/N						
100° Safety stat - Disconnect - the boiler should attempt to light and fail as a lockout Y/N						

Gas supply and combustion check

Satisfactory let by test	Y	N
Satisfactory tightness test	Y	N
Standing pressure		mb
Working pressure		mb
Gas rate		m ³ /hour See below

Flue analysis	Boiler 1		Boiler 2		Boiler 3		Boiler 4		Boiler 5		Boiler 6	
	Min	Max	Min	Max	Min	Max	Min	Max	Min	Max	Min	Max
Boiler Output												
CO ppm												
CO2 %												
Ratio												

Boiler output adjusted to installation requirement, adjuster "B" behind heating control knob(on cascade systems using the RVA control, set to maximum)		Y	N
---	--	---	---

- Gas rating using a meter recording in m³ (cubic metres)
- Turn off all gas appliances
- Record the meter reading in box 1
- Turn on the boiler and run at full output for two minutes(chimney sweep mode)
- Record the finish meter reading in box 2

Box2	
Box1	
Subtract 1 from 2	
divide by 2	
Multiply by 60	
Compare with	
60 BFR consumption	6 .14
100 BFR consumption	10 .22

m³/ hour. Multiply by 10.78 for approx KW input

	Boiler 1	Boiler 2	Boiler 3	Boiler 4	Boiler 5	Boiler 6
Boiler size						
Serial Number						
Completed By						
Date						

VENTILATION REQUIREMENTS

60 BFR boiler, installed as class C device only. Detailed recommendations for air supply are given in BS5440:2. The following notes are for general guidance:

- It is not necessary to have a purpose provided air vent in the room or compartment in which the appliance is installed. However, suitable clearances for maintenance and servicing should be provided, see fig. 1.

Ventilation requirements for 100 BFR boilers and cascade systems.

BS6644:2005 has a requirement that the temperatures in a room or compartment do not exceed certain levels:

- 25°C at floor level (0-100 mm)
- 32°C at mid level (1.5 M above the floor level)
- 40°C at ceiling level (0-100 mm from ceiling)

The following is provide for your guidance only, and assumes the ventilation air is taken directly from outside. The sizes of the vents may need to be increased in respect of other appliances installed in the same area, and seasonal use. Take care that the position of low level vents would not subject to adverse weather conditions, ie flooding.

When installed as a class B appliance (open flued, not roomed sealed).

Installed in a room

High level (within 15% of the room height from ceiling) - 2 cm²/KW of net heat input
 Low level (low as possible within 1 metre from floor natural gas, 250 mm LPG)- 4

cm²/KW of net heat input. Therefore a single **60 BFR** (58 KW net input) boiler would require 116 cm² at high level and 232 cm² at low level. A single **100 BFR** (98 KW net input) boiler would require 196 cm² at high level and 392 cm² at low level.

Installed in a compartment or enclosure

High level (within 15% of the room height from ceiling) - 5 cm²/KW of net heat input.
 Low level (low as possible within 1 metre from floor natural gas, 250 mm LPG) - 10 cm²/KW of net heat input.

Therefore a single **60 BFR** (58 KW net input) boiler would require 290 cm² at high level and 580 cm² at low level.

A single **100 BFR** (98 KW net input) boiler would require 490 cm² at high level and 980 cm² at low level.

When installed as a class C appliance (room sealed)

Installed in a room

High level (within 15% of the room height from ceiling) - 2 cm²/KW of net heat input
 Low level (low as possible within 1 metre from floor natural gas, 250 mm LPG)- 2 cm²/KW of net heat input

Therefore a single **60 BFR** (58 KW net input) boiler would require 116 cm² at high level and 116 cm² at low level.

A single **100 BFR** (98 KW net input) boiler would require 196 cm² at high level and 196 cm² at low level.

Installed in a compartment or enclosure

High level (within 15% of the room height from ceiling) - 5 cm²/KW of net heat input
 Low level (low as possible within 1 metre

from floor natural gas, 250 mm LPG)- 5 cm²/KW of net heat input.

Therefore a single **60 BFR** (58 KW net input) boiler would require 290 cm² at high level and 290 cm² at low level.

A single **100 BFR** (98 KW net input) boiler would require 490 cm² at high level and 490 cm² at low level.

CONDENSATE DISPOSAL POSITIONING AND TERMINATION OF THE CONDENSATE DRAIN PIPE (fig. 22)

The condensate pipe should run and terminate internally to the house soil and vent stack or waste pipe.

Alternatively, the condensate can be discharged into the rainwater system, or into a purpose-made soak away (condensate absorption point).

An alternative condensate waste pipe should be considered where the system could be effected by extreme weather conditions. All connecting drainage pipework should have a fall of at least 2.5° to the horizontal, or approximately 50 mm per metre of pipe run.

Material for condensate

The condensate drainage pipe should be run in a standard drain pipe material, e.g. PVC (polyvinyl chloride), PVC-U (unplasticised polyvinyl chloride), ABS (acrylonitrile-butadienestyrene), PP (polypropylene) or PVC-C (crosslinked polyvinyl chloride). The condensate drain can be attached to the syphon (see figures).

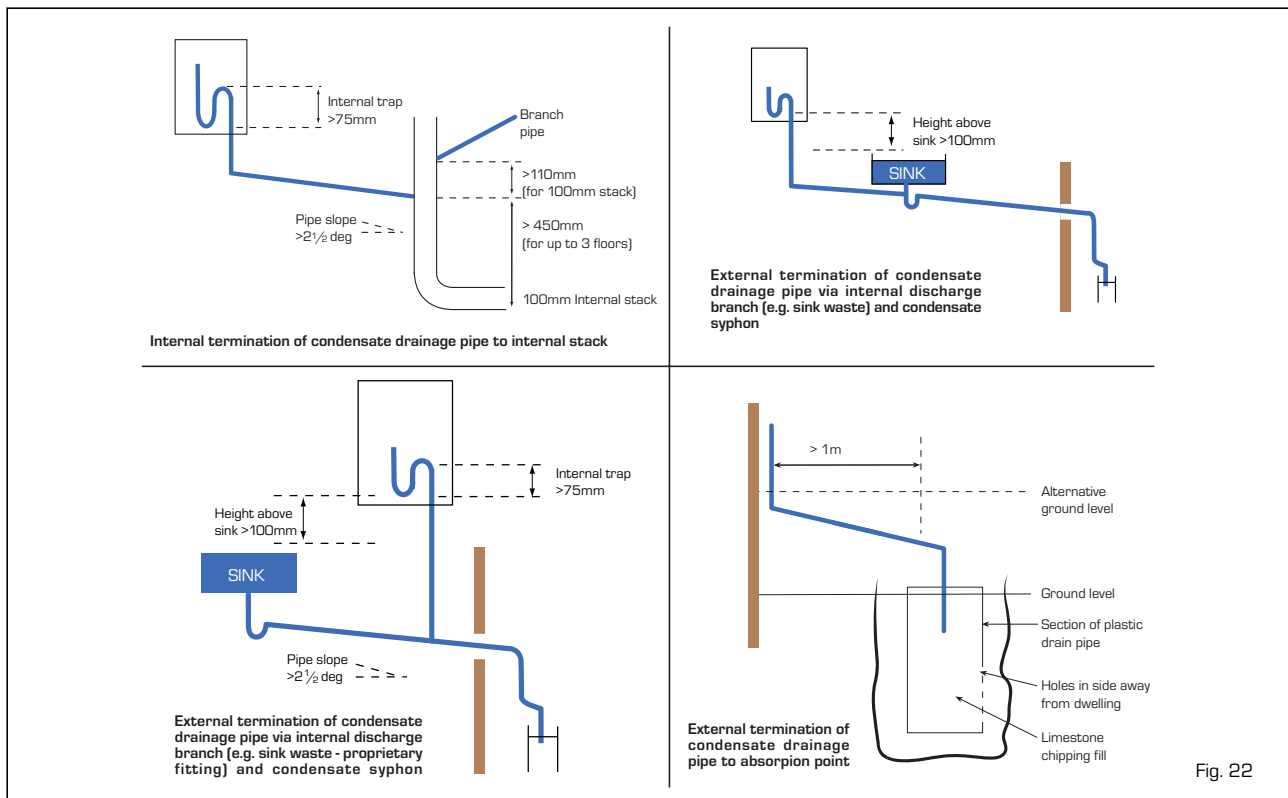

Fig. 22

5 EXPLODED VIEWS

COD. 3830005/345

TYPE PLANET DEWY 60 BFR UK

DATE 20.01.2010

PAGE 1/4

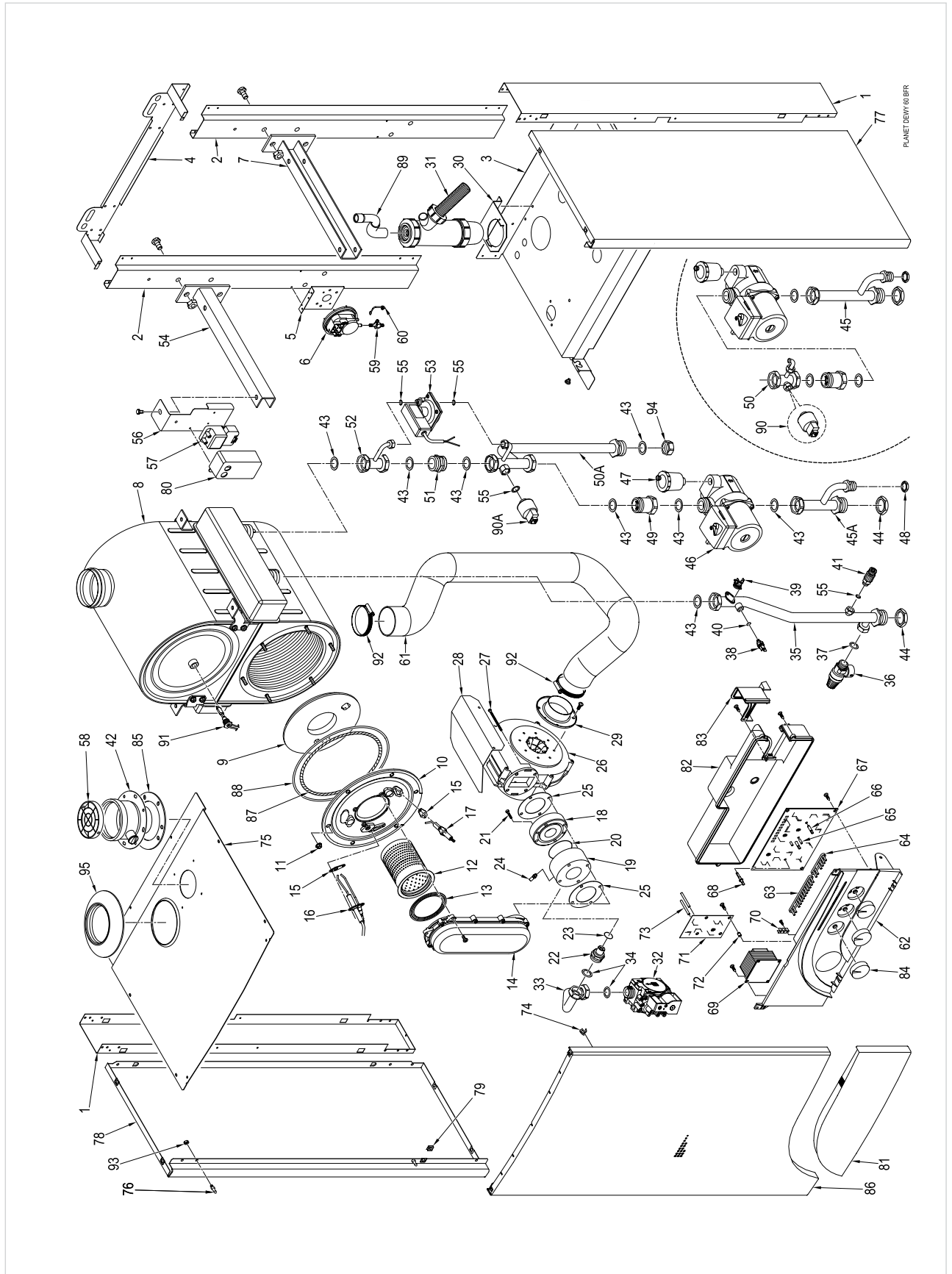

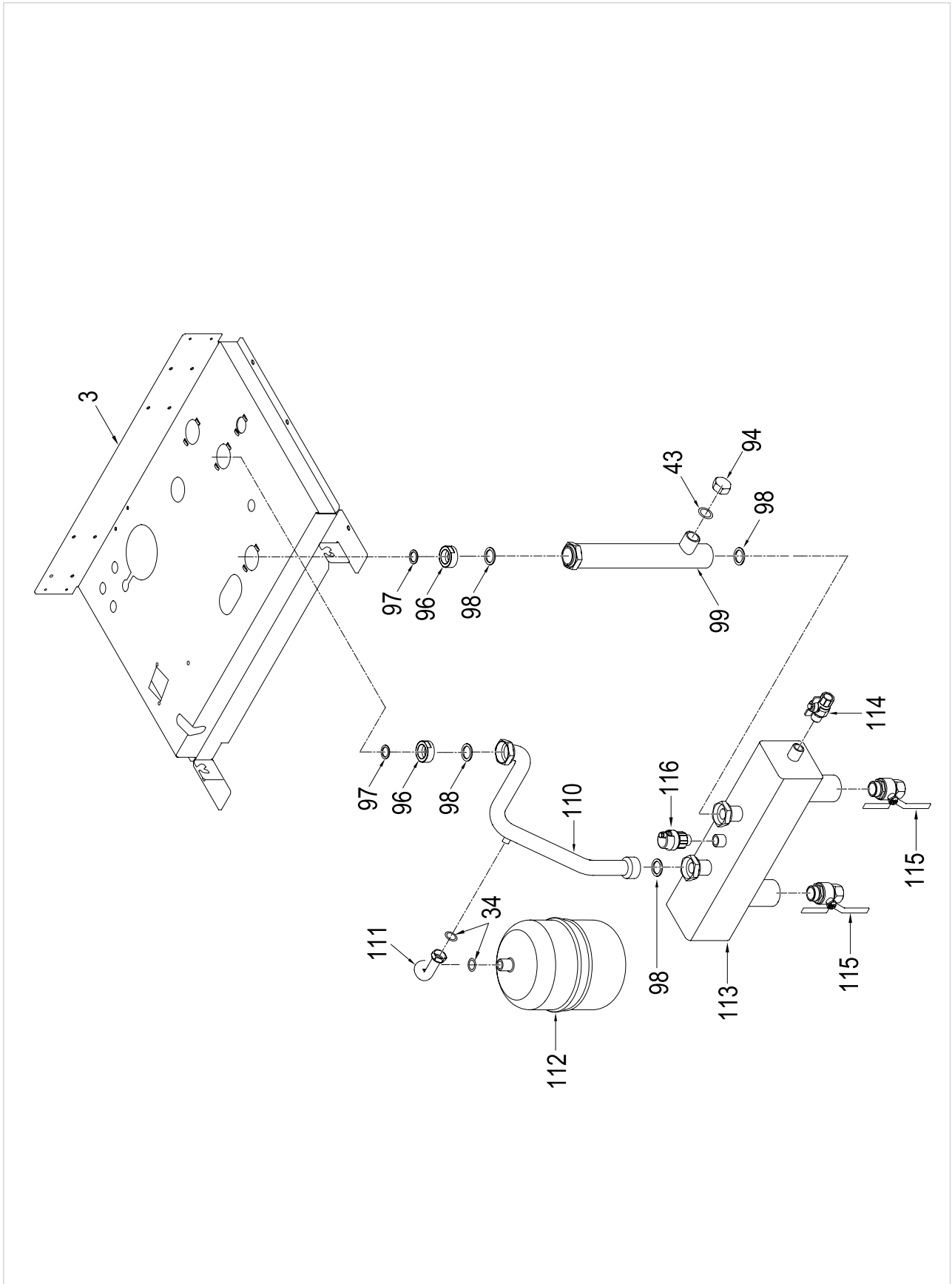

POSITION	CODE	DESCRIPTION	MODEL	NOTE
1	6138555	Right/left hand side frame part		
2	6256730	Main exchanger rear support		
3	6138811	Frame assembly lower side		
4	6138714	Frame assembly upper support		
5	6229101	Smoke pressure switch bracket		
6	6225710	Air pressure switch 35-45 Pa		
7	6294821	Main exchanger R.H. side support		
8	5188320	Main exchanger + brackets		
9	6269007	Main exchanger door insulation		
10	6278852	Main exchanger door		
11	6150010	Nut M6 OT		
12	6278306	Premix burner		
13	6174817	Gasket for burner flange		
14	6278803	Air-gas hose		
15	6174809	Gasket for ignition electrode		
16	6221622	Ignition electrode		
17	6221623	Ionisation electrode		
18	6274311	Upstream side mixer part		
19	6274310	Downstream side mixer part		
20	6226427	O-ring 156		
21	2000206	Screw M4 x 25		
22	6274141	Nozzle ø 9,30 natural gas		
23	6274140	Nozzle ø 6,70 LPG		
24	6226429	O-ring 121		
25	6235801	Pressure test nipple M6		
26	6174812	Mixer/hose gasket		
27	6261404	Fan FG148/1200-3612		
28	2000504	Screw M5 x 70		
29	6189567	am protection bracket		
30	6083053	Duct flange Ø 60		
31	6010822	Water trap bracket		
32	6277201	Water trap		
33	6243825	SIT 848 SIGMA gas valve		
34	6277407	Pipe connecting gas valve-mixer		
35	2030228	Gasket Ø 17x24x2		
36	6040206	Pressure relief valve 1/2" 4 bar		
37	2030227	Gasket Ø 12x18x2		
38	6231351	Plunged sensor		
39	6146722	95°C safety stat		
40	6022010	Sensor gasket		
41	6017210	Manual air vent 1/4"		
42	6083062	Flue inlet flange Ø 80		
43	2030229	Gasket Ø 22x30x2		
44	6146306	Brass nut 1" OT		
45	6277909	Pump connecting pipe		
45 A	6277925	Pump connecting pipe		
46	6124814	Circulating pump Grundfos UPS 15-70	CODE 8093577 FROM S.N. 3713301505	
47	6013100	Automatic air vent 3/8"		
48	6146301	Brass nut 1/2"		
49	6238303	Non return valve 1" Mx 1" F		
50	6277904	Transducer connecting pipe		
50 A	6277924	Transducer connecting pipe		
51	6120517	Nipple 1" x 1" OT with diaphragm		
52	6277906	Exchanger connecting pipe		
53	6211704	Differential pressure switch		
54	6294822	Main exchanger L.H. side support		
55	2030225	Gasket Ø 5,5x11x2		
56	6189562	Ignition transformer panel bracket		
57	6098350	Ignition transformer		
58	6190001	Intake terminal Ø 80		
59	6280500	3-ways junct. with press. test nipple		
60	6280550	Cap for 3-ways junction		
61	6001121	Flexible pipe Ø 60 L=1200		
62	6272900	Control panel		
63	6273200	Guidelight - 12 ways out		
64	6273201	Guidelight - 6 ways out		
65	6201501	Trimmer spindle Ø 5		
66	6201502	Trimmer spindle Ø 6		
67	6230696	Main PCB with ignition		
68	6201503	Selector spindle		
69	6240703	Transformer 230/24V		
70	2211610	Earth faston		
71	6260501	Fan driver PCB		
72	2213230	pacemaker h=6.4		
73	6201504	Trimmer spindle Ø 5 L=34		

* Recommended stock parts - Componenti da tenere a scorta

POSITION	CODE	DESCRIPTION	MODEL	NOTE	POSITION	CODE	DESCRIPTION	MODEL	NOTE
74	2015000	Spring clip M0/AB			6278636	4 pole female cable connector J7			
75	6010823	Upper protection shield			6293557	4 pole Lumb.-Mol. cable connector J1			
76	2003000	Pin M5 Zn			6293586	6 pole Stocko cable connector J5			
77	6274060	Casing right hand side panel			6293588	Ignition transformer lead			
78	6273960	Casing left hand side panel			6293589	7 pole Lumberg cable connector J4			
79	2013302	astener for self tapping screw			6293592	14 pole Lumberg cable connector J2			
80	6159710	Ignition transformer protection			6233506	Fuse T1,6A 250V			
81	6273300	Flap door			5185122	Conversion kit to L.P.G.			
82	6273000	Control panel protecting cover			6247701	3-ways junction			
83	6273100	Room stat cover			5188454	Complete control panel			
84	6230921	Knob Ø 40			6299970	6+4 pole Lumberg cable connector J3			
85	6028703	Gasket for duct flange			6231331	D.H.W. tank sensor			
86	6273516	Casing front panel			8102801	Kit: relay			
87	6278968	Glass fibre sealing cord			5199100	Filling loop			
88	6278967	ombustion chamber O-ring							
89	6034152	Condensate drainage rubber pipe							
90	5195700	Transducer kit							
90 A	5195701	Transducer kit							
90 B	6273603	Transducer							
91	5191990	Smoke stat kit							
92	2051200	Hose clamp Ø 50-70							
93	2010102	Nut M5 ZnCr							
94	6229502	Plug 1" F. OT							
95	6230402	External ring for pipe dia. 80 mm							
96	6120522	Reducer 1"1/2 x 1"							
97	2030222	Piracriten gasket 23x33x3							
98	2030206	Piracriten gasket Ø 33,5x45x2							
99	6291967	C.H. flow pipe							
110	6227424	C.H. return pipe							
111	6227680	Pipe connecting D.H.W. expans. vessel							
112	6245108	D.H.W. expansion vessel II, B							
113	6216312	Hydraulic compensator							
114	6216614	Cock 1/2"							
115	6216617	Cock 2"							
116	6013105	Automatic air vent 1/2"							
	6127210	Main cable L=2000							
	6186589	Ionisation lead L=600							
	6278613	8 pole cable connector TA-CR-SE-SB							

Products reference:

8093575: Planet Dewy 60 BFR

8093577: Planet Dewy 60 BFR

8101530: Hydraulic compensator kit and cocks

Check the correspondence with the boiler data plate.

• Recommended stock parts - Componenti da tenere a scorta

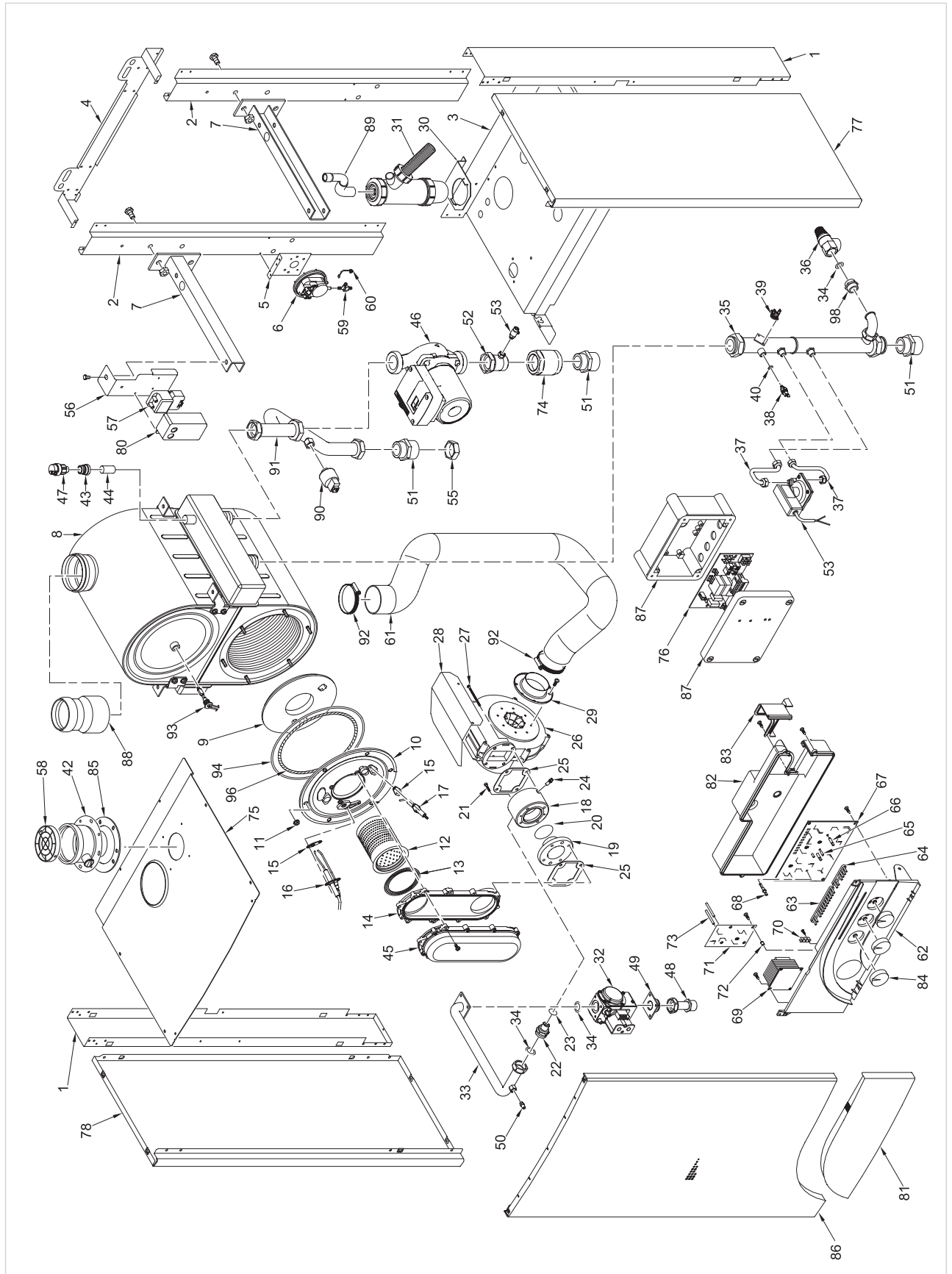

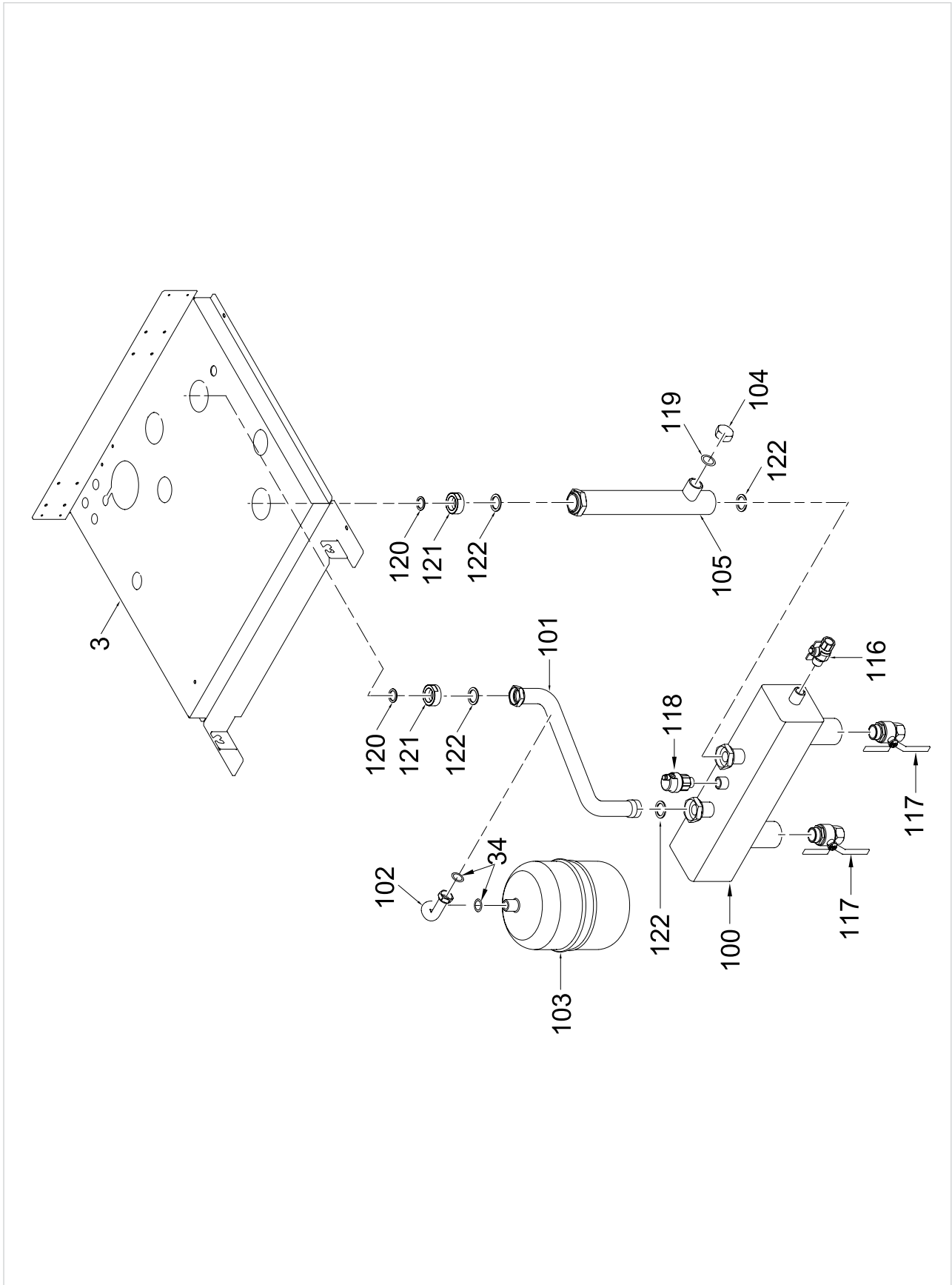

COD. **3830037/212**TYPE **Planet Dewy 100 BFR UK**

DATE

20.01.2010

PAGE

3/4

POSITION	CODE	DESCRIPTION	MODEL	NOTE
1	6138555	Right/left hand side frame part		
2	6256731	Main exchanger rear support		
3	6138833	Frame assembly lower side		
4	6138715	Frame assembly upper support		
5	6229101	Smoke pressure switch bracket		
6	6225707	Air pressure switch		
7	6294823	Main exchanger support		
8	6278915	Main exchanger body		
9	6269009	Main exchanger door insulation		
10	6278854	Main exchanger door		
11	6150010	Nut M6 OT		
12	6278310	Burner		
13	6174817	Gasket for burner flange		
14	6278806	Air-gas hose		
15	6174809	Gasket for ignition electrode		
16	6221622	Ignition electrode		
17	6221623	Ionisation electrode		
18	6274321	Upstream side mixer part		
19	6274320	Downstream side mixer part		
20	6226427	O-ring 156		
21	2000203	Screw TCEI M4x12		
22	6274160	Burner nozzle ø 11,00 natural gas		
22A	6274161	Main burner nozzle Ø 8,04 LPG		
23	6226407	O-ring 130 ø 22,22x2,62 XP70		
24	6235801	Pressure test nipple M6		
25	6174816	Gasket for fan flange		
26	6261409	Fan		
27	2000508	Screw TCB M5x75 ZnCr		
28	6189567	Fan protection bracket		
29	6083055	Duct flange Ø 60		
30	6010822	Water trap bracket		
31	6277201	Water trap		
32	6238510	Gas control		
33	6277414	Pipe connecting gas valve-mixer		
34	2030228	Gasket Ø 17x24x2		
35	6216237	C.H. flow pipe		
36	6040210	Pressure relief valve 3/4" 5 bar		
37	6277930	Flow pipe-pres. switch pipe		

• Recommended stock-parts - Componenti da tenere a scorta

POSITION	CODE	DESCRIPTION	MODEL	NOTE
38	6231351	Plunged sensor		
39	6146722	95°C safety stat		
40	6022010	Sensor gasket		
42	6083062	Flue inlet flange Ø 80		
43	6104710	Reduction		
44	6070815	Extension MM 3/4"		
45	6278890	Air-gas hose cover		
46	6124820	Circulating pump 25-60		
47	6013105	Automatic air vent 1/2"		
48	6226879	Gas inlet pipe		
49	6163101	Square flange with 1" connection		
50	6023100	Pressure test nipple Ø 1/8"		
51	6120529	Nipple 1 1/4 x 1 1/2		
52	6120528	Pipe fitting 1 1/4"		
53	6211706	Differential pressure switch		
54	6017211	Manual air vent 1/4"		
55	6229505	Plug 1-1/2"		
56	6189562	Ignition transformer panel bracket		
57	6098350	Ignition transformer		
58	6190001	Intake terminal Ø 80		
59	6280500	3-ways junct. with press. test nipple		
60	6280550	Cap for 3-ways junction		
61	6001121	Flexible pipe Ø 60 L=1200		
62	6272900	Control panel		
63	6273200	Guidelight - 12 ways out		
64	6273201	Guidelight - 6 ways out		
65	6201501	Trimmer spindle Ø 5		
66	6201502	Trimmer spindle Ø 6		
67	6230696	Main PCB with ignition		
68	6201503	Selector spindle		
69	6240703	Transformer 230/24V		
70	2211610	Earth faston		
71	6260501	Fan driver PCB		
72	2213230	Spacer h=6.4		
73	6201504	Trimmer spindle Ø 5 L=34		
74	6238304	Non return valve		
75	6010836	Upper protection shield		
76	6260505	PCB		

POSITION	CODE	DESCRIPTION	MODEL	NOTE
77	6274070	Casing right hand side panel		
78	6273970	Casing left hand side panel		
80	6159710	Ignition transformer protection		
81	6273300	Flap door		
82	6273000	Control panel protecting cover		
83	6273100	Room stat cover		
84	6230921	Knob Ø 40		
85	6028703	Gasket for duct flange		
86	6273516	Casing front panel		
87	6002714	Junction box		
88	6296527	Reducer DN 80-100"		
89	6034155	Condensate drainage pipe		
90	6273603	Water pressure transducer		
91	6227427	C.H. return pipe		
92	2051200	Hose clamp Ø 50-70		
95	6230402	External ring for pipe dia. 80 mm		
98	6120502	Nipple 3/4"x3/4" OT		
100	6216313	Hydraulic compensator		
101	6227428	C.H. return pipe		
102	6227683	Pipe connecting D.H.W. expans. vessel		
103	6245108	D.H.W. expansion vessel I. 8		
104	6229502	Plug 1" F. OT		
105	6291967	C.H. flow pipe		
116	6216614	Cock 1/2"		
117	6216617	Cock 2"		
118	6013105	Automatic air vent 1/2"		
119	2030229	Gasket diam. 22x30x2		
120	2030222	Piracriten gasket 23x33x3		
121	6120522	Reducer 1 1/2x1"		
122	2030206	Piracriten gasket diam. 33,5x45x2		
	6127210	Main cable L=2000		
	6186589	Ionisation lead L=600		
	6278613	8 pole cable connector TA-CR-SE-SB		
	6293557	4 pole Lumb.-Moi. cable connector J1		
	6293589	7 pole Lumberg cable connector J4		
	6293592	14 pole Lumberg cable connector J2		
	6247701	3-ways junction		
	5188458	Complete control panel		

• Recommended stock parts - Componenti da tenere a scorta

POSITION	CODE	DESCRIPTION	MODEL	NOTE
	6316241	6+4 pole cable connector Stocko		
	6316242	6+4 pole cable connector Lumberg		
	6293560	2 pole Molex cable connector		
	5188460	Electric Box group		
	6316240	2 pole cable connector Stocko		
	6316204	Connector 8 pole CN7		
	6231331	D.H.W. tank sensor		
	8102801	Kit relay		
	5199100	Filling loop		
	5185124	Conversion kit to LPG		
		Products reference:		
	8101531	Hydraulic compensator kit and cocks		
	8104950	Planet Dewy 100 BFR		
		Check the correspondence with the boiler data plate.		



Sime Ltd

1a Blue Ridge Park
Thunderhead Ridge
Glasshoughton, Castleford, WF10 4UA

Phone: 0845 9011114

Fax: 0845 9011115

www.sime.co.uk

Email: enquiries@sime.co.uk