

GB

Format 30 HE

*Installation and
servicing instructions*

benchmark™

*The code of practice for the installation,
commissioning & servicing for central heating systems*

WRAS
APPROVED
PRODUCT

 **sime®**

These appliances comply with the S.E.D.B.U.K. scheme, band "A"

CONTENTS

1	DESCRIPTION OF THE BOILER	pag.	1
2	INSTALLATION	pag.	5
3	CHARACTERISTICS	pag.	11
4	USE AND MAINTENANCE	pag.	14
5	FAULT FINDING	pag.	17
6	REPLACEMENT OF PARTS	pag.	20
7	EXPLODED VIEWS	pag.	22



**The code of practice for the installation,
commissioning & servicing for central heating systems**

Please refer to commissioning instructions for filling in the log book

Note: All CORGI registered installers carry a CORGI ID Card.
You can check your installer is CORGI Registered by calling 01256 372300

SIME COMBINATION BOILERS

Installer checklist

Please remember to carry out the following checks after installation. This will achieve complete customer satisfaction, and avoid unnecessary service calls. A charge will be made for a service visit where the fault is not due to a manufacturing defect.

- Has a correct by-pass been fitted and adjusted?
- Has the system and boiler been flushed?
- Is the system and boiler full of water, and the correct pressure showing on the pressure gauge?
- Is the Auto Air Vent open?
- **Has the pump been rotated manually?**
- Is the gas supply working pressure correct?
- Is the boiler wired correctly? (See installation manual).
- **Has the D.H.W. flow rate been set to the customer requirements?**
- Has the customer been fully advised on the correct use of the boiler, system and controls?
- Has the log book provided been completed?
- **Has the Aquaguard Filter been cleaned (see 4.9)?**

1 DESCRIPTION OF THE BOILER

1.1 INTRODUCTION

“FORMAT 30 HE” boilers are high efficiency pre-mix condensing thermal appliances

which use microprocessor technology for function control and management.

The boiler is equipped as standard with frost protection and circulating pump anti-

jamming system.

The instructions given in this manual are provided to ensure proper installation and perfect operation of the appliance.

1.2 DIMENSIONS

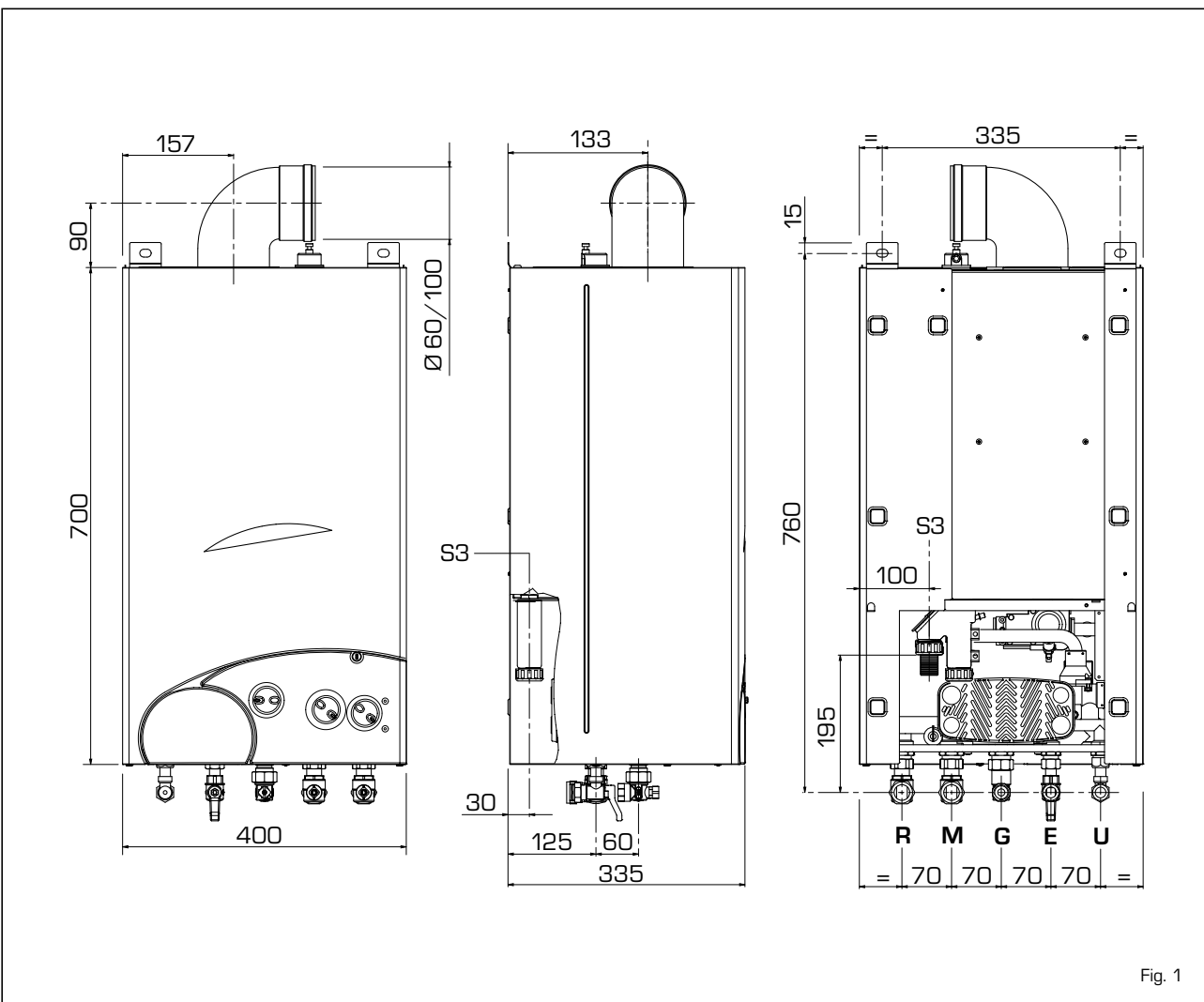

TABLE 1 - Connections

R	C.H. return	22 mm	Compression
M	C.H. flow	22 mm	Compression
G	Gas connection	1/2 in	Bsp
E	D.H.W. inlet	15 mm	Compression
U	D.H.W. outlet	15 mm	Compression
S3	Condensation outlet ø 22		

TABLE 2 - Minimum clearances

	For ventilation	For servicing
ABOVE THE APPLIANCE CASING	200 mm	300 mm
AT THE R.H.S.	15 mm	15 mm
AT THE L.H.S.	15 mm	15 mm
BELOW THE APPLIANCE CASING	200 mm	200 mm
IN FRONT OF THE APPLIANCE	350 mm	500 mm

1.3 TECHNICAL FEATURES

FORMAT 30 HE		
Heat output nominal (80-60°C)	kW (kcal/h)	27.3 (23,480)
Heat output nominal (50-30°C)	kW (kcal/h)	29.8 (25,630)
Heat output minimum (80-60°C)	kW (kcal/h)	10.2 (8,770)
Heat output minimum(50-30°C)	kW (kcal/h)	11.3 (9,720)
Heat input nominal	kW (kcal/h)	27.9 (24,000)
Heat input minimum	kW (kcal/h)	10.5 (9,030)
Nominal D.H.W. heat input	kW (kcal/h)	30.0 (25,800)
Minimum D.H.W. heat input	kW (kcal/h)	10.5 (9,030)
Efficiency nom./min. output (80-60°C)	%	97.9/97.0
Efficiency nom./min. output (50-30°C)	%	106.9/107.4
Seasonal efficiency rating (SEDBUK)		90.2% (A)
Termal efficiency (CEE 92/42 directive)		★★★★
Class NOx		5
Smokes temperature maximum (80-60°C)	°C	63
Smokes temperature minimum(80-60°C)	°C	56
Smokes temperature maximum (50-30°C)	°C	42
Smokes temperature minimum (50-30°C)	°C	41
Smokes flow	kg/h	47
CO ₂ maximum/minimum G20	%	9.0/9.0
CO ₂ maximum/minimum G31	%	10.0/9.9
Adsorbed power consumption	W	145
Electrical protection grade	IP	X4D
CE certification	n°	1312BP4098
Category		IIH3P
Type		B23-53
		C13-33-43-53-83

FORMAT 30 HE		
CENTRAL HEATING		
Maximum water head	bar	3
Maximum temperature	°C	80
Water content boiler	l	5.3
C.H. setting range	°C	20/75
Expansion vessel capacity	l	8
Expansion vessel pressure	bar	1
DOMESTIC HOT WATER		
Minimum/maximum pressure	bar	0.5/7.0
D.H.W. flow rate (EN 625)	l/min	13.4
Continuous D.H.W. flow rate Δt 30°C	l/min	14.3
Continuous D.H.W. flow rate Δt 35°C	l/min	12.3
Minimum D.H.W. flow rate	l/min	2
D.H.W. setting range	°C	30/60
GAS PRESSURE AND NOZZLES		
Gas supply pressure G20	mbar	20
Gas supply pressure G31	mbar	37
Nozzles quantity	n°	1
Nozzles diameter G20	ø	7.0
Nozzles diameter G31	ø	5.0
C.H. gas consumption nom./min. G20	m ³ /h	2.95/1.11
C.H. gas consumption nom./min. G31	kg/h	2.17/0.82
D.H.W. gas consumption nom./min. G20	m ³ /h	3.17/1.11
D.H.W. gas consumption nom./min. G31	kg/h	2.33/0.82

WEIGHT	kg	43
---------------	----	----

1.4 FUNCTIONAL DIAGRAM

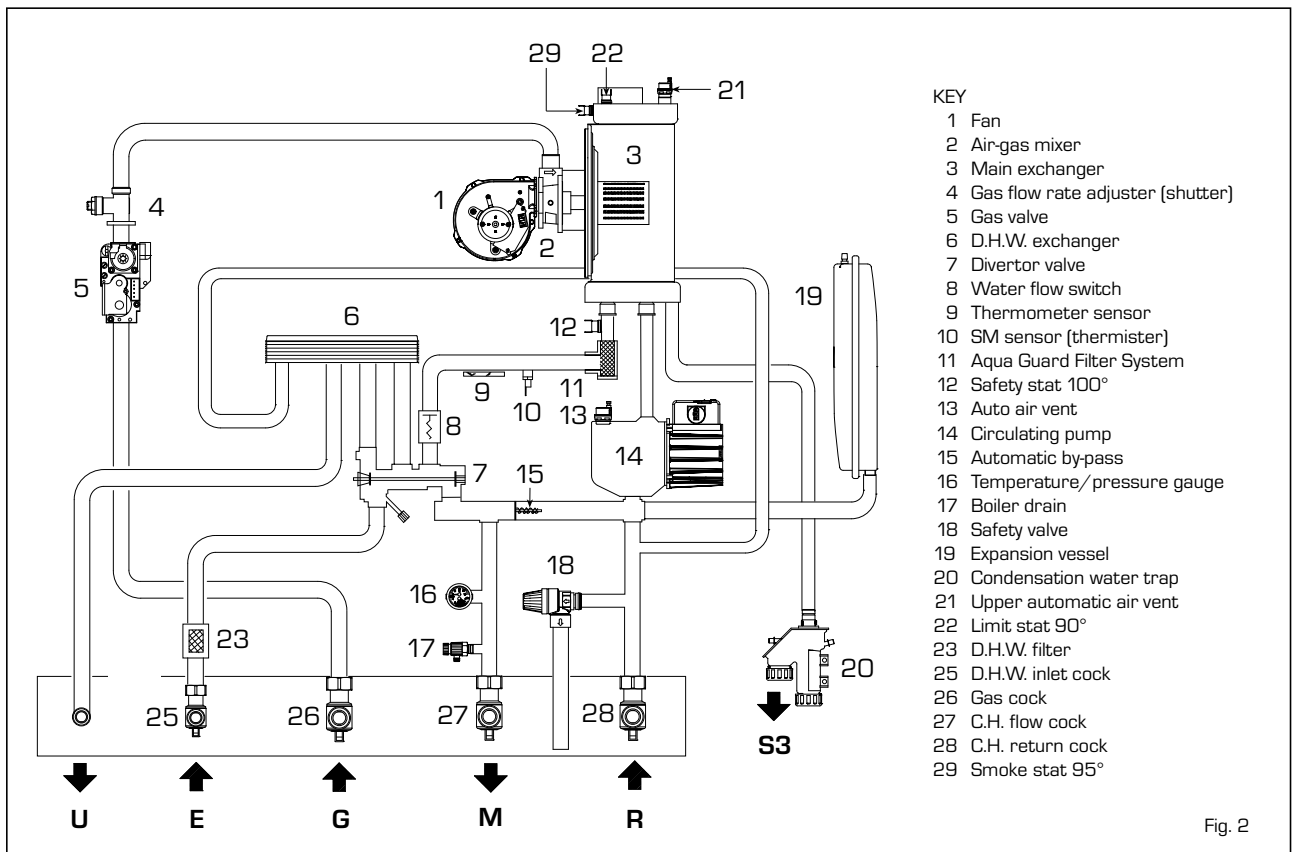

1.5 MAIN COMPONENTS

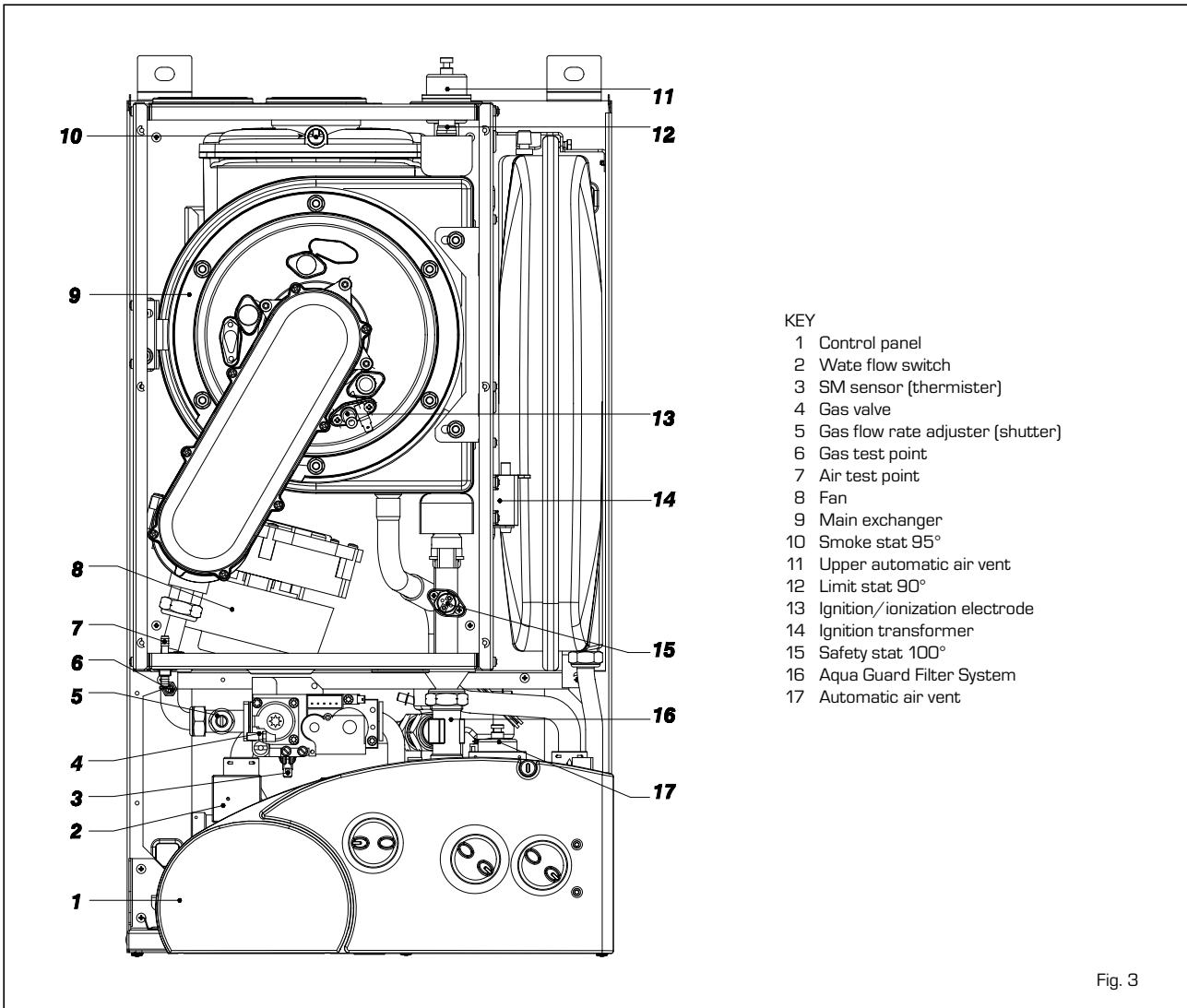

Fig. 3

2 INSTALLATION

The boiler must be installed in a fixed location and only by specialized and qualified person in compliance with all instructions contained in this manual. Furthermore, the installation must be in accordance with current standards and regulations.

2.1 VENTILATION REQUIREMENTS

Detailed recommendations for air supply are given in BS5440:2. The following notes are for general guidance:

- It is not necessary to have a purpose provided air vent in the room or compartment in which the appliance is installed.

2.2 FIXING THE WALL MOUNTING BRACKET

- Mark the position of the two wall mounting bracket fixing holes and the flue/air duct hole on the appropriate wall(s).
- Drill the top two fixing holes using a 10 mm masonry drill and fit the plastic plugs provided.
- Cut the hole in the wall for the flue/air duct. The diameter should not be less than 100 mm (4 in) and must be horizontal. If the hole is not accessible from the outside of the building, its minimum diameter should be sufficient to allow the insertion of the wall liner (130 mm - 5 1/4 in diameter) which will be sealed with mortar.
- Accurately measure the wall thickness, and note this dimension for later use.
- Secure the wall mounting bracket in position using the screws provided. Ensure that it is the correct way up, as indicated in fig. 4.

2.3 CONNECTING UP SYSTEM

Before proceeding to connect up the boiler, you are recommended to flush out the system in order to eliminate any foreign bodies that might be detrimental to the operating efficiency of the appliance. When making the hydraulic connections, make sure that the clearances indicated in fig. 1 are respected. To facilitate the hydraulic connections the boiler is equipped with a valve pack code 5184803 complete with instructions sheet.

A safety valve set at 3 bar is fitted to the appliance, the discharge pipe provided should be extended to terminate safely away from the appliance and where a discharge would not cause damage to persons or property but would be detected. The pipe should be a minimum of 15 mm Ø and should be able to withstand boiling water; any should avoid sharp corners or upward pipe runs where water may be retained.

The gas connection must be made using seamless steel or copper pipe

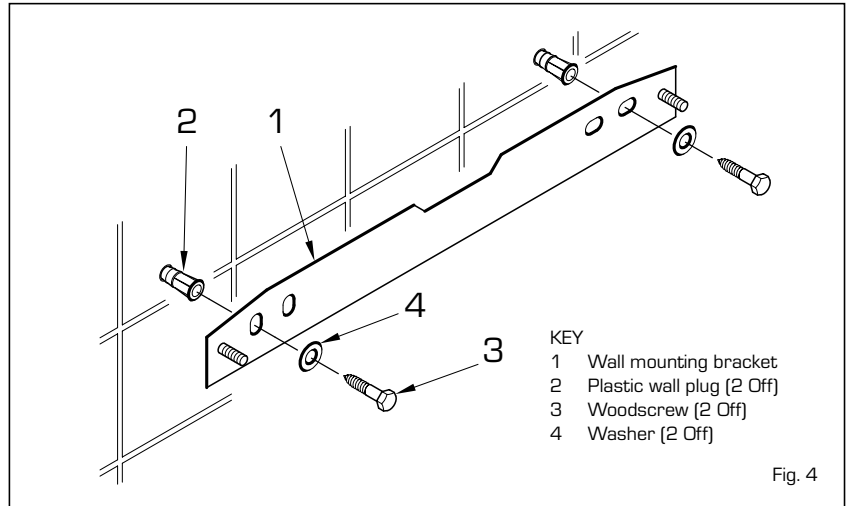

Fig. 4

(Mannesmann type), galvanized and with threaded joints provided with gaskets, excluding three-piece connections, except for initial and end connections. Where the piping has to pass through walls, a suitable insulating sleeve must be provided. When sizing gas piping, from the meter to the boiler, take into account both the volume flow rates (consumption) in m³/h and the relative density of the gas in question. The sections of the piping making up the system must be such as to guarantee a supply of gas sufficient to cover the maximum demand, limiting pressure loss between the gas meter and any apparatus being used to not greater than 1.0 mbar for family II gases (natural gas). An adhesive data badge is sited inside the front panel; it contains all the technical data identifying the boiler and the type of gas for which the boiler is arranged.

2.3.1 Connection of condensation water trap

The drip board and its water trap must be connected to a civil drain through a pipe with a slope of at least 5 mm per metre to ensure drainage of condensation water.

The plastic pipes normally used for civil drains are the only type of pipe which is appropriate for conveying condensation to the building's sewer pipes.

2.3.2 Requirements for sealed water systems

The heating system design should be based on the following information:

- The available pump head is given in fig. 16.
- The appliance is equipped with an internal by-pass that operates with system heads (H) greater than 3 m. The maximum flow through the by-pass is about 300 l/h. If thermostatic radiator valves are to be installed, at least one radiator should be without a thermostatic valve (usually the bathroom radiator).

2.4 CHARACTERISTICS OF FEEDWATER

- All recirculatory systems will be subject to corrosion unless an appropriate water treatment is applied. This means that the efficiency of the system will deteriorate as corrosion sludge accumulates within the system, risking damage to pump and valves, boiler noise and circulation problems.
 - For optimum performance after installation this boiler and its associated central heating system must be flushed in accordance with the guidelines given in BS 7593 "Treatment of water in domestic hot water central heating systems".
 - This must involve the use of a proprietary cleanser, such as Sentinel X300 or X400, or Fernox Superfloc. Full instructions are supplied with the products, but for immediate information please contact GE Betz (0151 420 9563) or Fernox (01799 550 811) directly.
 - For long term protection against corrosion and scale, after flushing it is recommended that an inhibitor such as Sentinel X100, or Fernox MB-1 or Copal is dosed in accordance with the guidelines given in BS 7593.
- Failure to flush and add inhibitor to the system may invalidate the appliance warranty.**
- It is important to check the inhibitor concentration after installation, system modification and at every service in accordance with the manufacturer's instructions. (Test kits are available from inhibitor stockists).
 - At every service the Aquaguard Filter (4.9) should be checked and cleaned.

2.5 COAXIAL DUCT ø 60/100

The air inlet-smoke outlet assembly, code 8096201, is included in the standard supply of the appliance complete with mounting instructions.

NOTE: to use only special accessories for condensing boilers.

2.5.1 Coaxial duct accessories

The accessories to be used for this type of installation and some of the connecting systems that may be adopted are illustrated in fig. 5. **With the pipe bend included in the kit, the maximum length of the piping should not exceed 4.6 meter. Where the supplementary bend code 8095800 is used, the total length of the piping can reach a maximum of 2.9 meter. When the vertical extension code 8086907 is used, the terminal part of the pipe must always come out horizontally.**

2.5.2 Positioning the outlet terminals

The outlet terminals for forced-draught appliances may be located in the external perimeter walls of the building. To provide some indications of possible solutions, **Table 3** gives the minimum distances to be observed, with reference to the type of building shown in fig. 6.

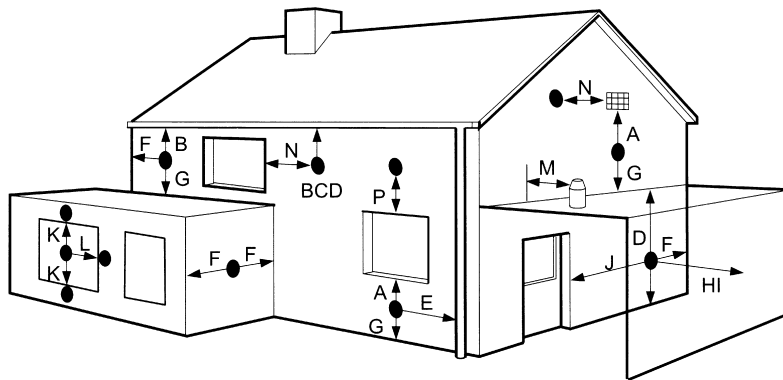
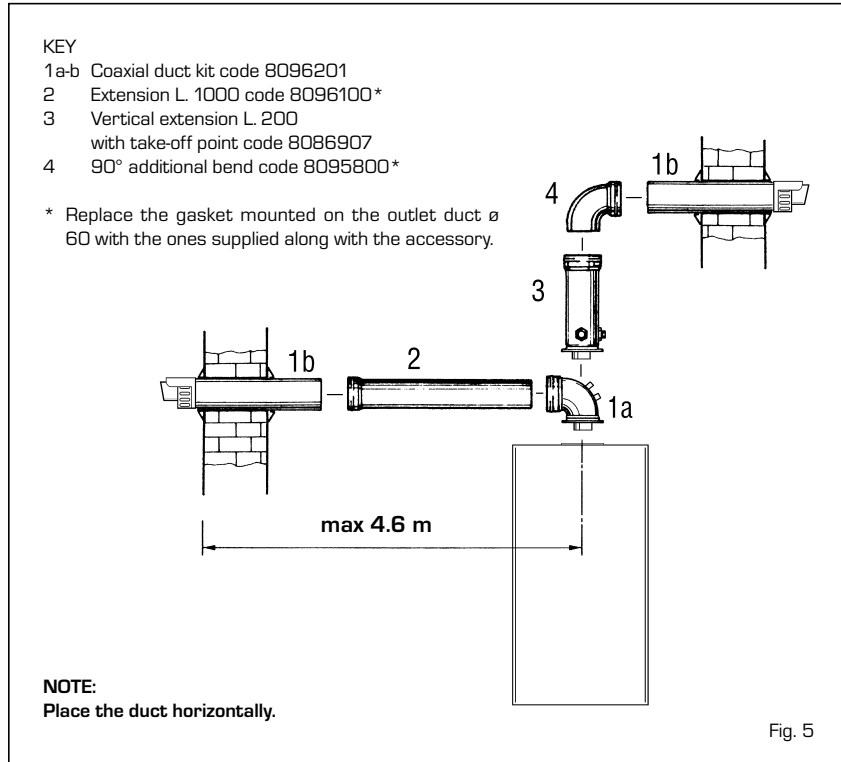
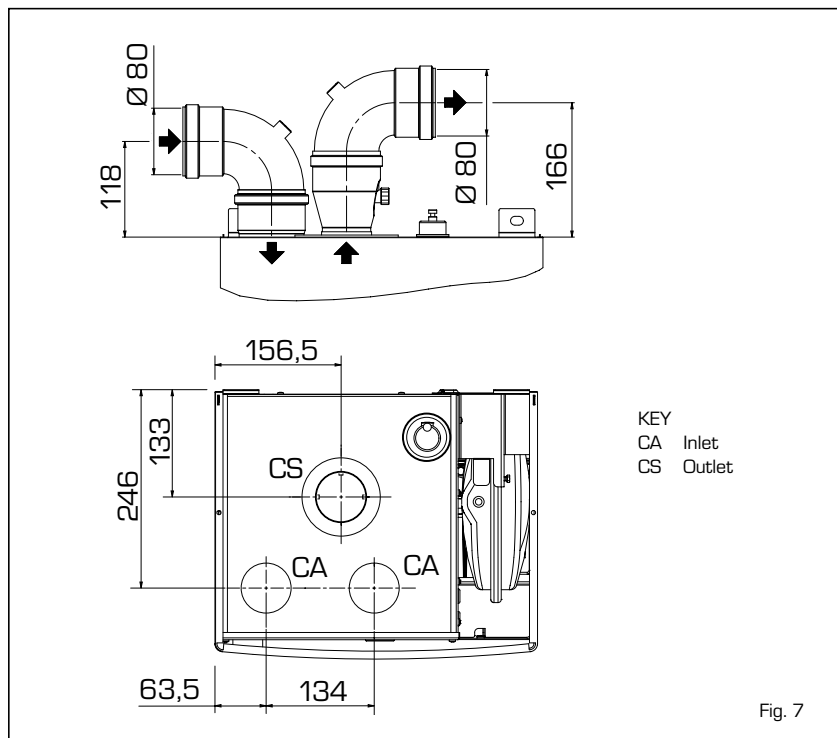

TABLE 3

Terminal position	Minimum spacing
A Directly below an openable window, air vent or any other ventilation opening	300 mm 12 in
B Below guttering, drain pipes or soil pipes	75 mm 3 in
C/D Below eaves, balconies or carport roof	200 mm 8 in
E From vertical drain pipes or soil pipes	75 mm 3 in
F From internal or external corners	300 mm 12 in
G Above adjacent ground, roof or balcony level	300 mm 12 in
H From a surface facing the terminal	600 mm 24 in
I From a terminal facing the terminal	1,200 mm 48 in
J From an opening in the carport (eg door; window into dwelling)	1,200 mm 48 in
K Vertically from a terminal on the same wall	1,500 mm 60 in
L Horizontally from a terminal on the same wall	300 mm 12 in
M Horizontally from a vertical terminal to a wall	300 mm 12 in
N Horizontally from an openable window or other opening	300 mm 12 in
P Above an openable window or other opening	300 mm 12 in

- If the terminal discharges into a pathway or passageway check that combustion products will not cause nuisance and that the terminal will not obstruct the passageway.
- Where the lowest part of the terminal is fitted less than 2 m (78 in) above ground, above a balcony or above a flat roof to which people have access, the terminal **MUST** be protected by a purpose designed guard. Terminal guards are available from Quinnell, Barrett, and Quinnell, Old Kent Road, London. State model C2, (G.C. Part No 382946).
- Where the terminal is fitted within 850 mm (34 in) of a plastic or painted gutter, or 450 mm (18 in) of painted eaves, an aluminium shield at least 1,500 mm (59 in) long must be fitted to the underside of the painted surface.
- The air inlet/outlet flue duct **MUST NOT** be closer than 25 mm (1 in) to combustible material.
- In certain weather conditions the terminal may emit a plume of steam. This is normal but positions where this would cause a nuisance should be avoided.

Fig. 6



2.6 SEPARATE PIPES ø 80 (Optional alternative twin pipe system)

A special kit may be used to separate the flue gas outlet from the fresh air intake. The intake may be installed to the right or left of the flue gas outlet. Both ducts may be oriented in any direction. Refer to fig. 7 for positioning.

The maximum overall length of the intake and exhaust ducts depends on the head losses of the single fittings installed (excluding the doublers) and must not be greater than 13 mm H₂O. For head losses in the fittings, refer to Table 4.

NOTE:

To use only special accessories for condensing boilers.

2.6.1 Separate pipe accessories

Kit code 8089907 is supplied for this purpose (fig. 8).

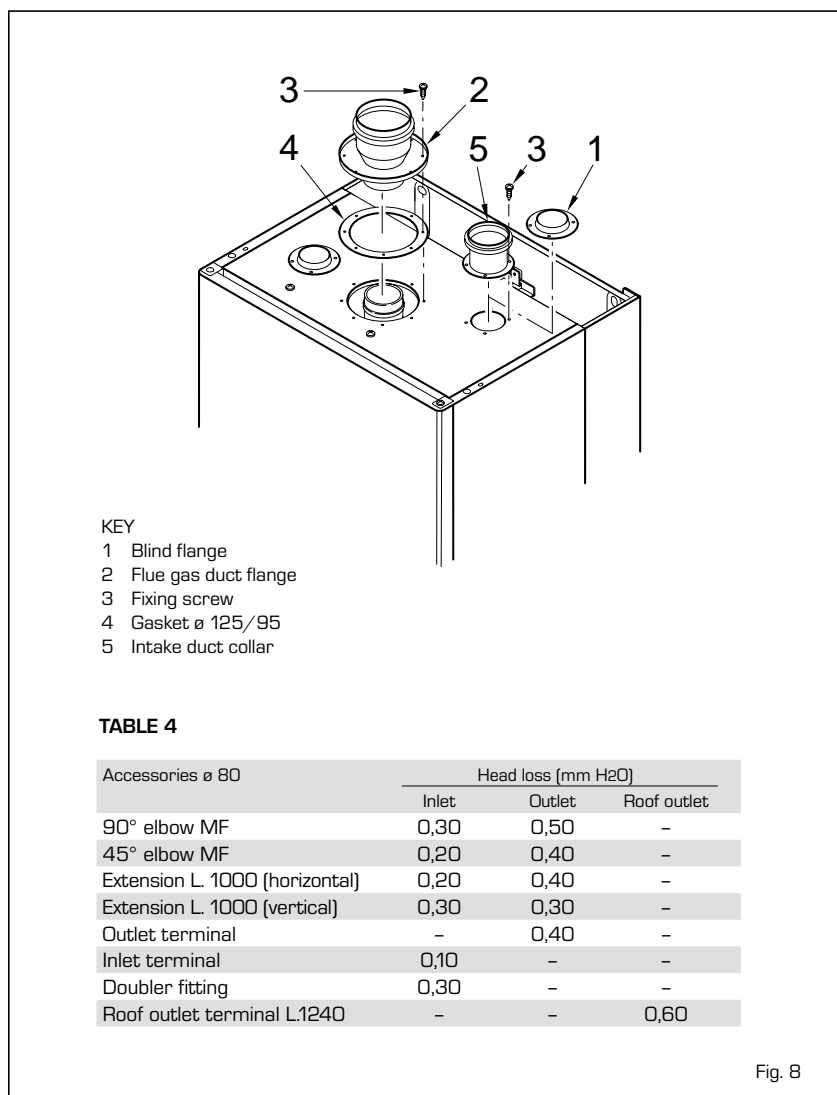

2.8 ELECTRICAL CONNECTION

The boiler is supplied with an electric cable. Should this require replacement, it must be purchased exclusively from SIME.

The electric power supply to the boiler must be 230V - 50Hz single-phase through a fused main switch, with at least 3 mm spacing between contacts.

Respect the L and N polarities and the earth connection.

NOTE:

SIME declines all responsibility for injury or damage to persons, animals or things, resulting from the failure to provide for proper earthing of the appliance.

2.8.1 Electrical board (fig. 12)

Prior to any operation, always turn off the power supply. Remove the three screws (7) fixing the control board, and pull forward the panel until it tilts downwards. In order to gain access to the electrical board components, unscrew the four screws (6) fixing the control panel cover.

2.8.2 Room thermostat (fig. 12)

After having removed the jumper, connect electrically the room thermostat to terminals 1-2 of the junction box (5).

In order to have better room comfort and temperature control, we suggest you to use a room thermostat belonging to Class II, as specified by standard EN60730.1 (clean contact).

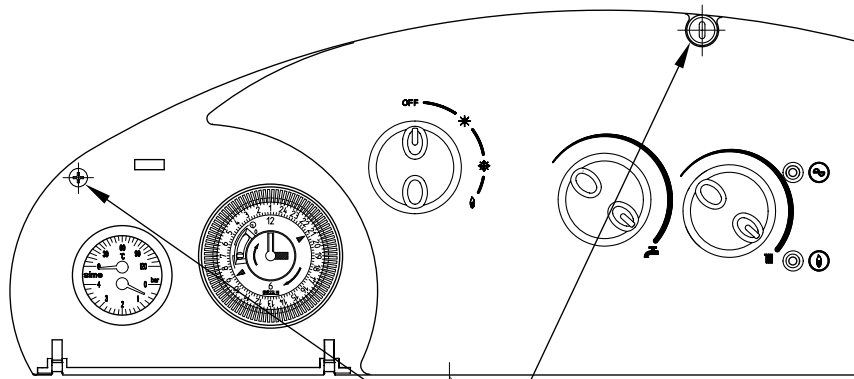

ATTENTION: After having removed the three screws [7] tilt the panel downwards to gain access.

7

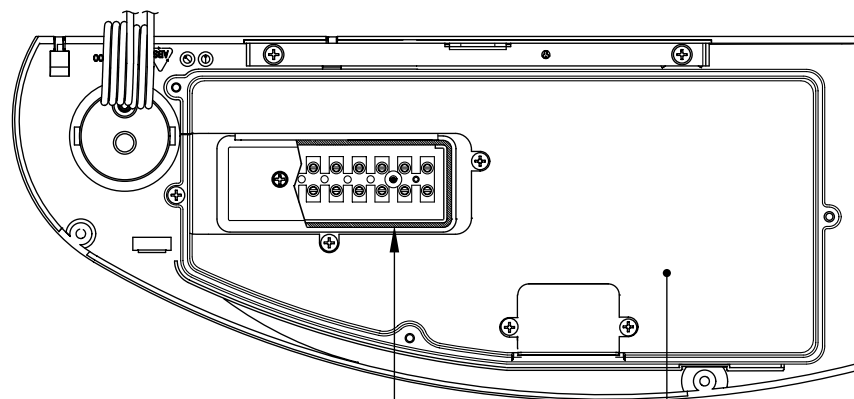

5

6

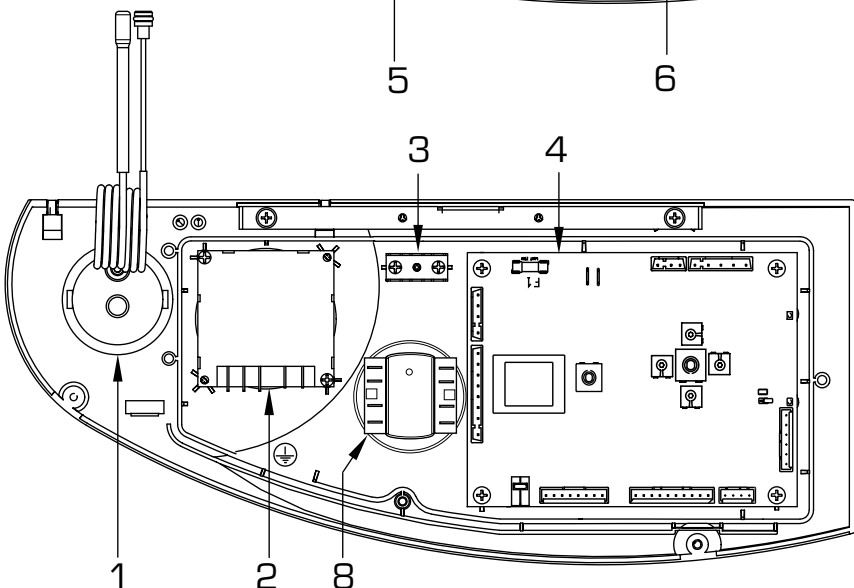

1

2

8

3

4

KEY

- 1 Pressure/temperature gauge
- 2 Heating programmer (optional)
- 3 Earth faston
- 4 Main electronic board

- 5 9 pole terminal strip
- 6 Control panel cover
- 7 Fixing screw
- 8 Selector OFF/SUMMER/WINTER/RESET

Fig. 12

2.8.3 Wiring diagram

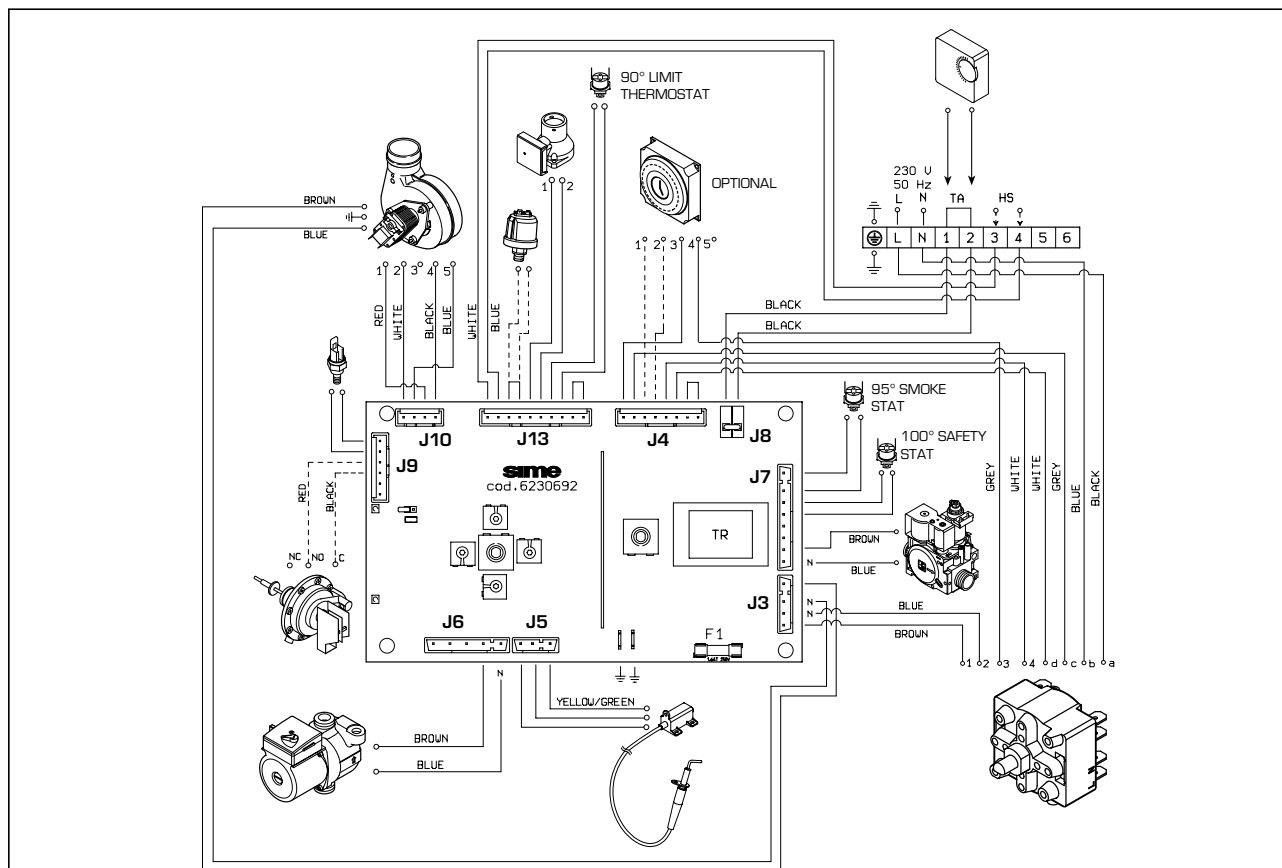

NOTE:

- The room thermostat may be connected to the terminals 1-2 of the "TA" connector after having removed the link.
- To remote control the boiler connect an external clock to the terminals 1-2 (24 V) of the "TA" connector and set the built-in clock to "constant" mode (see user instructions for details).

JUMPERS POSITION AND FEATURES

JUMPER	POSITION AND FEATURE		SUPPLY POSITION
	CLOSED	OPEN	
JP1 - DELAY CANCELLATION*	Ignition delay cancelled	Ignition delay operating	Open
JP2 - DIVERTOR VALVE/D.H.W. PUMP	Use with div. valve	Use with boiler pump	Closed

* In the heating phase, the electronic board is programmed to include a burner technical delay interval of approx. 3 minutes, which occurs both at system cold starting and at subsequent re-ignitions. The aim is to overcome the problem of repeated ignitions and turning off with very short time intervals between. This could occur in particular in systems presenting high head losses. At each restart after the period of slow ignition, the boiler will set itself for about 1 minute at the minimum modulation pressure, and will then move to the heating pressure value set.

Fig. 13

2.9 TIME PROGRAMMER (optional)

The control panel is designed to allocate a timer-programmer, code 8092214 (digital time clock 1 channel) or code 8092213 (mechanical 24 Hour time clock), which can be supplied upon request.

To fit the timer, remove the housing blanking piece from the control panel and, with the panel open, fit the timer to the panel using the screws supplied therein (see fig. 13/a).

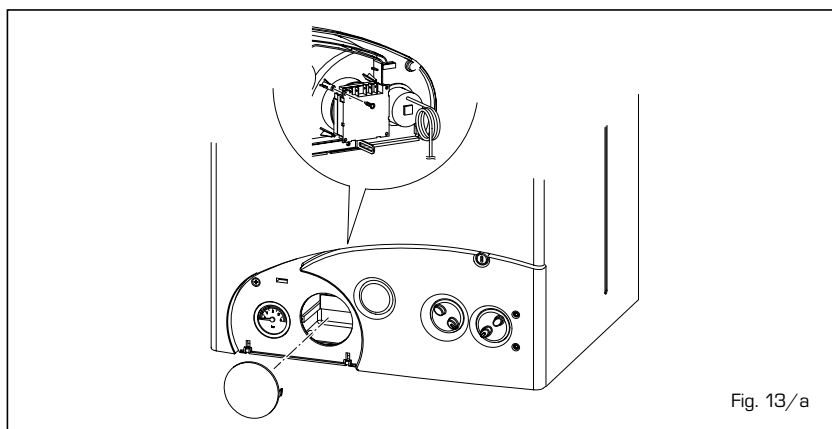

Fig. 13/a

3 CHARACTERISTICS

3.1 ELECTRONIC BOARD

The electronic board is manufactured in compliance with the EEC 73/23 low-voltage directives. It is supplied with 230V. The electronic components are guaranteed against a temperature range of 0 up to +60°C. An automatic and continuous modulation system enables the boiler to adjust power to the various system requirements or the user's needs.

3.1.1 Fault and malfunction signaling

The indicator LEDs signaling irregular and/or incorrect operation of the equipment are indicated in fig. 16.

3.1.2 Devices

The electronic board is equipped with the following devices (fig. 15):

- "POT. RISC." trimmer (pos. 6)

Sets the maximum heating power value. To increase the value turn the trimmer clockwise; to reduce the value turn the trimmer anticlockwise.

- "POT. ACC." trimmer (pos. 3)

Trimmer to vary the pressure level upon ignition (STEP), of the gas valve. It has been factory set with ignition STEP at 95 Hz. To increase pressure, turn the trimmer clockwise; to reduce pressure, turn the trimmer counterclockwise. The slow

ignition pressure level can be set during the first 7 seconds following burner ignition discharge. **After setting the pressure level upon ignition (STEP) according to the type of gas, check that the gas pressure for heating is still at the value previously set.**

- "JP1" connector (pos.10)

In the heating phase, the electronic board is programmed to include a burner technical delay interval of approx. 180 seconds, which occurs at every ignition after a forced stop. By "forced stop", we indicate a stop due

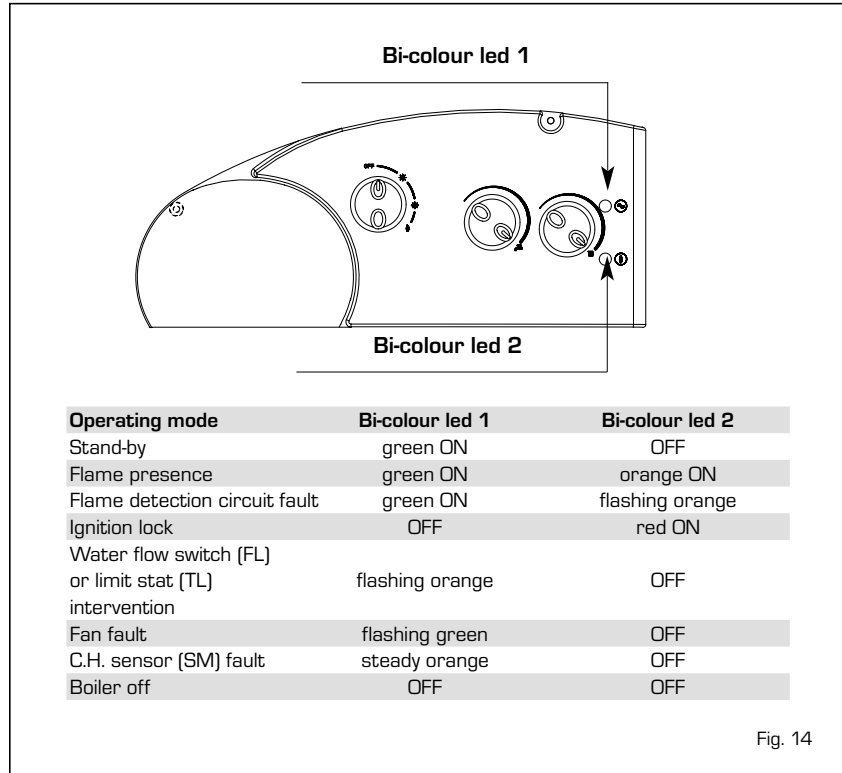

Fig. 14

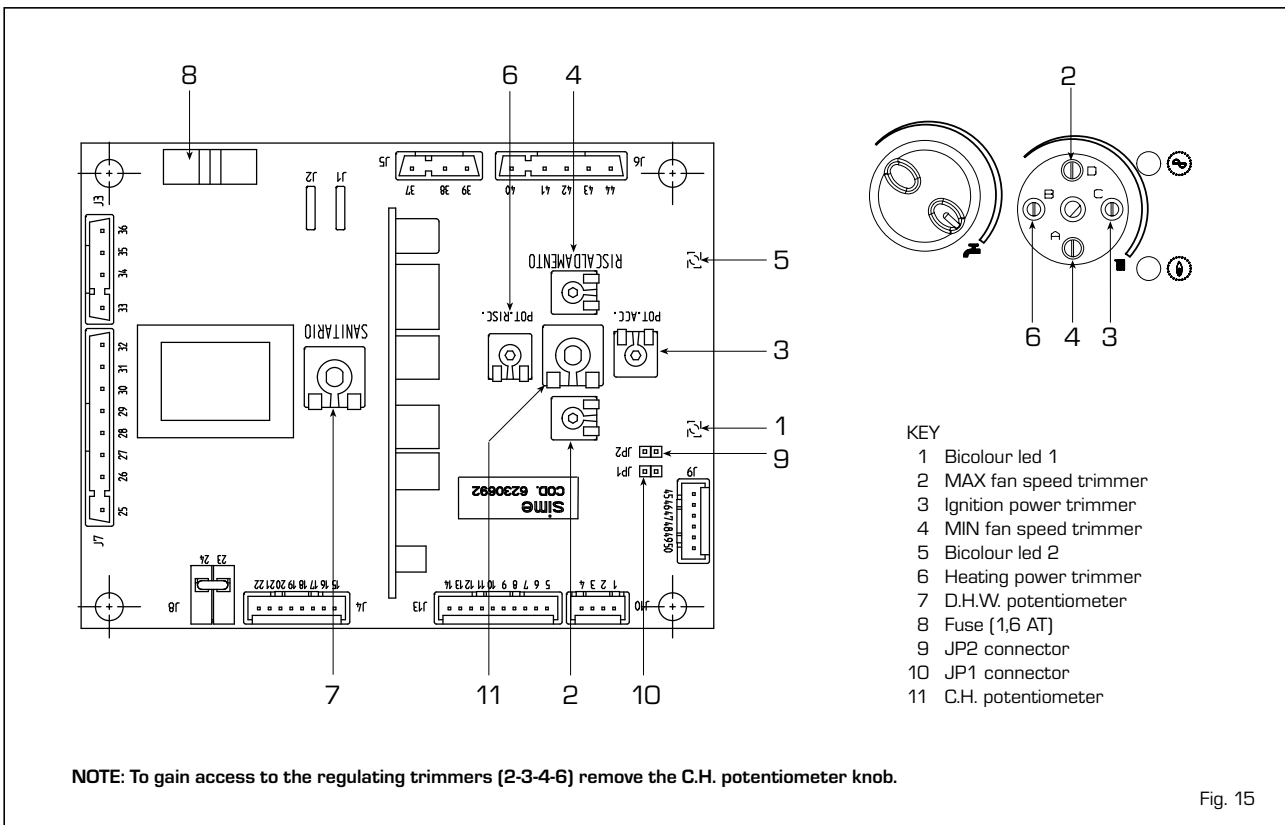

Fig. 15

to a sensor (SM) temperature difference of more than 5°C to temperature set at heating potentiometer:

The aim is to overcome the problem of repeated ignitions and turning off with very short time intervals between. This could occur in particular in systems presenting high load losses. At each restart after the period of slow ignition, the boiler sets itself for about 1 minute at the minimum modulation pressure, and then moves to the heating pressure value set. When the jumper is inserted, both the programmed technical pause and the period of operation at minimum pressure in the startup phase are cancelled. In this case, the times elapsing between turning off and subsequent re-ignition will depend on a temperature difference of 5°C detected by the SM sensor (heating flow sensor).

- "JP2" connector (pos. 9)
Must be fitted.
- "MAX" fan maximum speed trimmer (pos.2)
To set fan at a maximum speed.
- "MIN" fan minimum speed trimmer (pos.4)
To set fan at a minimum speed.

ATTENTION: It is essential that all operations described above are carried out by authorized technical staff. If not, the warranty is invalid.

3.2 TEMPERATURE SENSOR

Antifreeze system managed by active heating NTC sensor when water temperature is 6°C. The heating sensor works also as a limit thermostat which switches off the burner when temperature is over 80°C. Reset temperature is set at 75°C. **When sensor (SM) is interrupted, neither of the boiler's heating services will function.**

Table 5 shows the resistance values (Ω) obtained on the heating sensor as the temperature varies.

TABLE 5

Temperature (°C)	Resistance (Ω)
20	12.090
30	8.313
40	5.828
50	4.161
60	3.021
70	2.229
80	1.669

3.3 ELECTRONIC IGNITION

Ignition and flame detection is controlled by a sole electrode located on the burner. It guarantees maximum safety with intervention times, for accidental switching off or gas failure, within one second.

3.3.1 Operating cycle

Rotate the selector knob to summer or winter, and verify that green LED (⓪) lights up to confirm the presence of voltage.

The burner must be ignited within 10 seconds max.

However, it is possible for ignition failures to occur, with consequent activation of "locked out" signal:

- **Gas failure**
The electrode continues spark discharge for a maximum of 10 sec. If the burner does not light, the board - after a 5 second ventilation stop - reactivates discharge for further 10 seconds. This cycle will be repeated 5 times, after that, the lock-out red LED will light up.

This may occur upon first ignition or after long periods of boiler lay-off when there is air in the pipes.

It may be caused by the gas cock being closed or by one of the valve coils having a break in the winding, so that the valve cannot open.

- **Ignition electrode fails to spark**
The electrode continues spark discharge for a maximum of 10 sec. If the burner does not light, the board - after a 5 second ventilation stop - reactivates discharge for further 10 seconds. This cycle will be repeated 5 times, after that, the lock-out red LED will light up.

This may be due to a break in the wire of the electrode or to the wire not properly fastened to the ignition transformer terminal.

The electrode itself may touch earth or may be heavily worn out and needs repla-

cing. The electronic board is defective.

When there is a sudden voltage failure, the burner shuts down immediately; when the power supply returns, the boiler will start up again automatically.

3.4 FLOW SWITCH SAFETY VALVE

A flow switch safety valve (8 fig. 2) intervenes, blocking the operation of the burner if the boiler is without water due to the formation of air bubbles in the heat exchanger or if the circulator is not working correctly or because the "Aqua Guard" heating circuit filter is clogged.

3.5 SYSTEM AVAILABLE HEAD

The head available for the heating plant is shown as a function of the flow in graph in fig. 16. To obtain the maximum head available to the system, turn off the by-pass by turning the union to the vertical position (fig. 16/a).

3.6 ELECTRICITY CONNECTION FOR ZONE SYSTEMS

To realize this kind of system, use a separate electricity supply to connect the room thermostats and relative zone valves.

The micro or relay contact connection has to be made to 1-2 connectors of the 9-pole junction box after having removed the jumper (fig. 17).

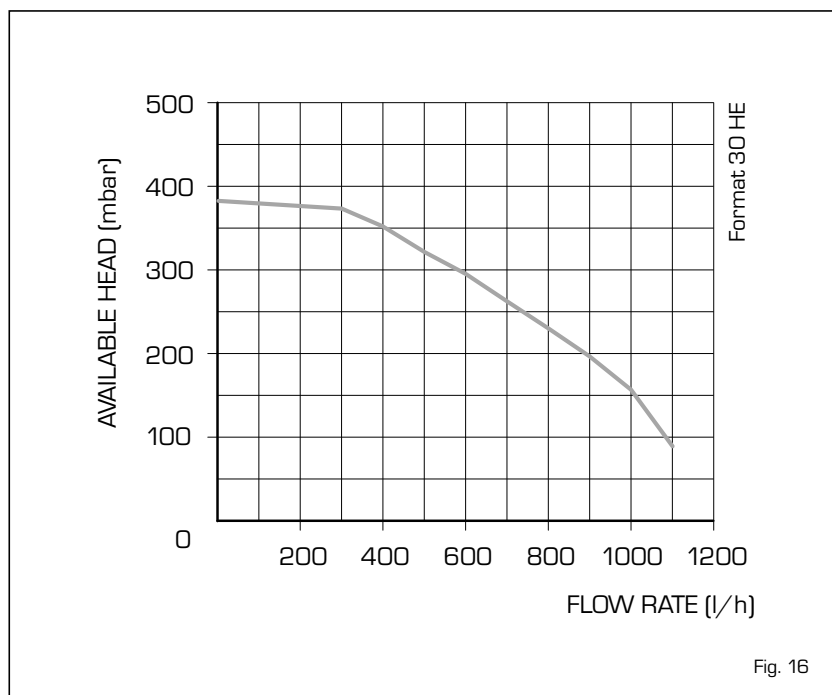

Fig. 16

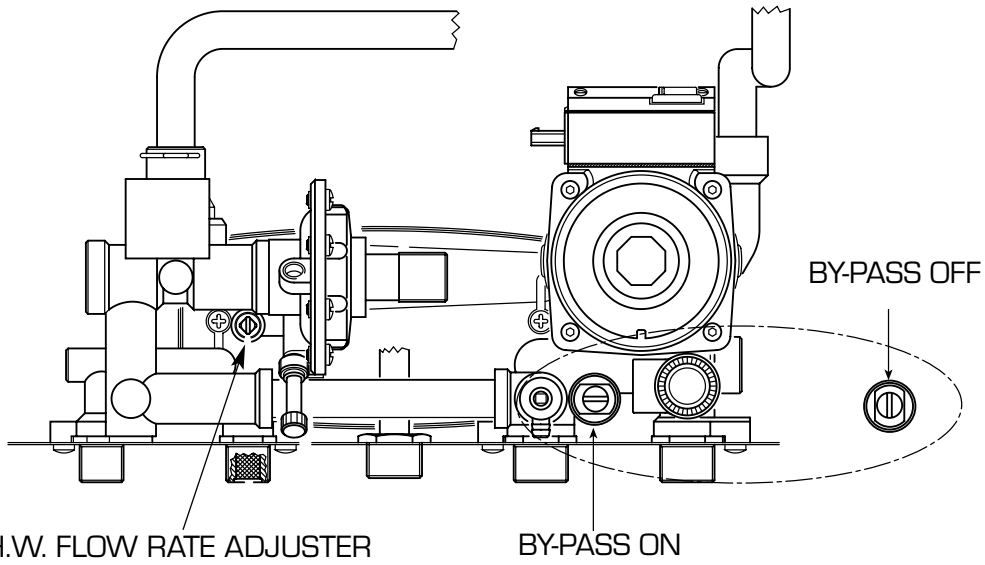
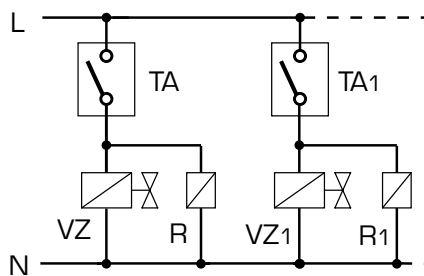
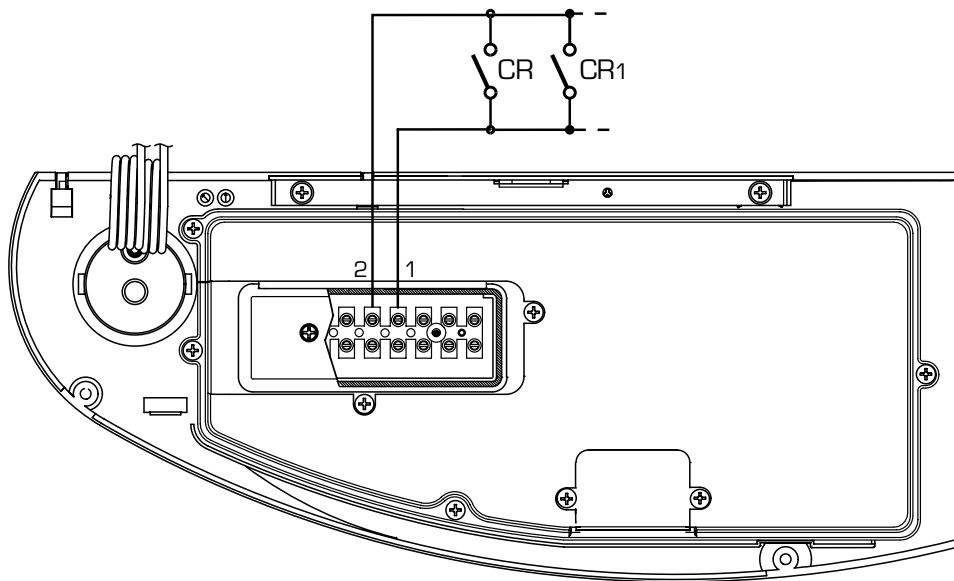

Fig. 16/a



- KEY
 TA-TA1 Zone room stat
 VZ-VZ1 Zone valves
 R-R1 Zone relay
 CR-CR1 Zone microvalve or relay contact

NOTE: Relays are used only if the area valves have no microswitches.

Fig. 17

4 USE AND MAINTENANCE

SIME SUPPORT THE BENCHMARK INITIATIVE

All relevant sections of the logbook must be filled in at the time of installation and thereafter service information on the back page of the logbook. Commissioning of the boiler is not complete until the logbook is filled in.

4.1 FILLING THE WATER SYSTEM

- Open the flow and return valves (27 - 28 fig. 2).
- Loosen the automatic air vent cap (13-21 fig. 2).
- Open all radiator valves and system air vents. Fill the system with water using one of the approved methods described in section 2.3.2 to about 0.5 bar greater than the system design pressure. Close all air vents. Do not close the A.A.V. (13-21 fig. 2).
- Check the system for water soundness.
- Completely drain the appliance and heating system, thoroughly flush the system, and refill the system design pressure.
- Before refilling check and clean the Aquaguard filter (4.9).

4.2 GAS VALVE

The boiler is equipped standard with the HONEYWELL VK 4115V gas valve (fig. 18).

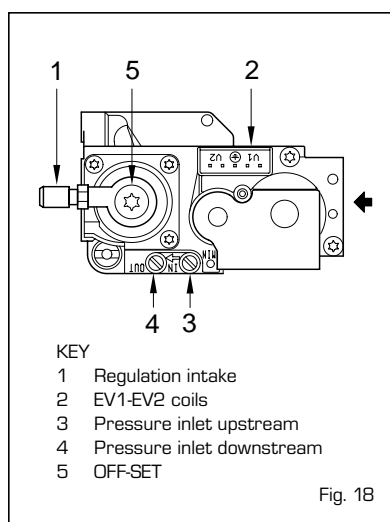

4.3 ADJUSTMENT OF HEAT OUTPUT FOR HEATING

To adjust boiler heat output for heating purposes, i.e., modifying the setting made at the factory which is approximately 17 kW, use a screwdriver to adjust the heating heat output trimmer (6 fig. 15). To increase working pressure, turn the trimmer clockwise; to reduce pressure, turn the trimmer counterclockwise. To determine boiler heat output setting (for both natural

Test pointers inserted on "HS" terminals in order to measure Hz at the fan.

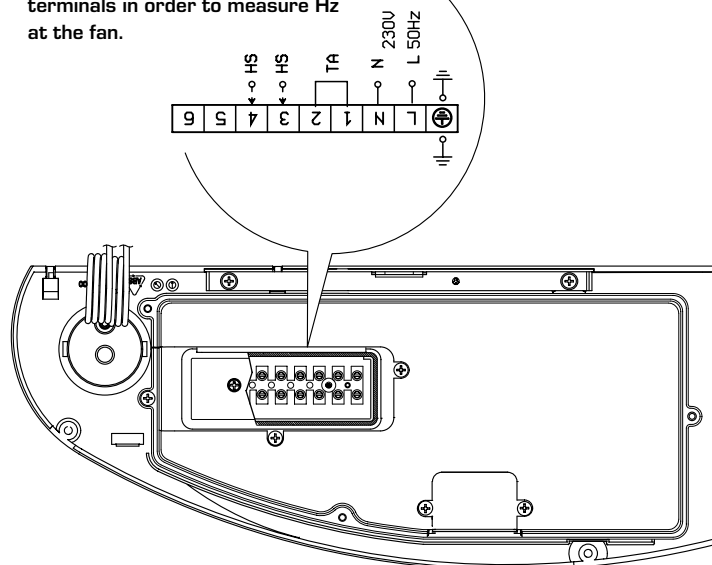

TABLE 6

Hertz	Pressure mbar	Heating output	
		(80/60°C) kW	(50/30°C) kW
70	1.24	10.2	11.3
90	2.05	10.7	16.1
110	3.06	14.6	18.2
130	3.71	16.6	22.5
150	4.94	20.5	26.7
185	7.52	29.4	32.1

Fig. 19

gas and propane gas), check Hertz value shown in **Table 6** (fig. 19) or check the pressure connect the positive of the manometer to the gas test point (6 fig. 3).

4.4 CALIBRATION PROCEDURE IN HEATING PHASE USING HERTZ (fig.20)

- 1) Turn heating manometer knob to maximum. Check that water temperature at heating system is lower than 75°C.
- 2) Turn the trimmer (6) anti-clockwise as far as it will go to minimum power.
- 3) Open completely the gas capacity step (7) by turning the screw anti-clockwise until end of stroke.
- 4) Adjust trimmer (4) and check that Hertz value is between 68 and 72.
- 5) Adjust the gas valve OFF-SET (8) in order to achieve a CO₂ value of 10.8% for natural gas or of 10.9% for propane. To increase CO₂ value, turn the screw clockwise; to reduce it turn the screw anti-clockwise.
- 6) Adjust gas capacity step (7) in order to achieve a CO₂ value of 8.9% for natural gas or of 9.8% for propane. To reduce CO₂ value, turn the screw clockwise.
- 7) Go to maximum power by turning clockwi-

se trimmer (6) as far as it will go.

- 8) Adjust the trimmer (2) and check that the Hertz value of the fan is between 172 and 176b.
- 9) Check that CO₂ value is approx. 9.0% for natural gas or 10.0% for propane. In case the value would not be correct, repeat calibration procedure as mentioned in point 4.

4.5 CALIBRATION PROCEDURE IN HEATING PHASE USING MBAR

1) Adjust air pressure (fan speed)

Connect the positive of the manometer to the positive test point of sealed chamber (7 fig. 3). Disconnect the SM sensor and connect a loose one free in air, or activate the chimney sweep function (4.11).

Sequence (Fig. 20)

- Turn the heating output potentiometer to maximum output.
- Turn the heating output trimmer B to minimum.
- Adjust the minimum air pressure using fan speed trimmer A.
- Turn the DHW output potentiometer to maximum.

- Fully open a domestic hot water tap.
- Adjust the maximum air pressure using fan speed trimmer D (2 fig. 20).

AIR PRESSURE	
Minimum	Maximum
(mm H ₂ O)	(mm H ₂ O)
12.5/13.5	86/88

2) Adjust gas pressure

Connect the positive of the manometer to the gas test point (6 fig. 3).

Sequence (Fig. 20)

- Turn heating output potentiometer to maximum output.
- Turn the heating power trimmer B to minimum.
- Adjust the minimum gas pressure using the OFF-SET (8) on the gas valve.
- Turn the DHW output potentiometer to maximum output.
- Fully open a domestic hot water tap.
- Adjust the maximum gas pressure using the gas valve shutter (7).

GAS PRESSURE	
Minimum	Maximum
(mm H ₂ O)	(mm H ₂ O)
10.5/11.5	69/71

CO₂ VALUE %

	Natural gas	LPG
Minimum output	8.7/9.3	9.7/10.3
Maximum output	8.7/9.3	9.7/10.3

- To adjust CO₂ at maximum output adjust the gas valve OFF-SET.
- To adjust CO₂ at minimum output to adjust the gas valve shutter.

VERY IMPORTANT:

It's not necessary to adjust the gas pressure or the fan speed should the boiler be converted to another gas (ie natural gas to LPG) only the injector will require changing.

4.6 GAS CONVERSION

A kit complete with instructions for transformation is supplied for G31 propane gas conversion.

4.7 DISASSEMBLY OF EXPANSION VESSEL

To disassemble the expansion vessel, proceed as follows:

- Make sure that the water has been emptied out of the boiler.
- Unscrew the connection and the locknut.
- Remove the expansion vessel.

Before refilling the system, using a pressure gauge attached to the valve make sure that the expansion vessel is preloaded at a pressure of 0.8 to 1 bar.

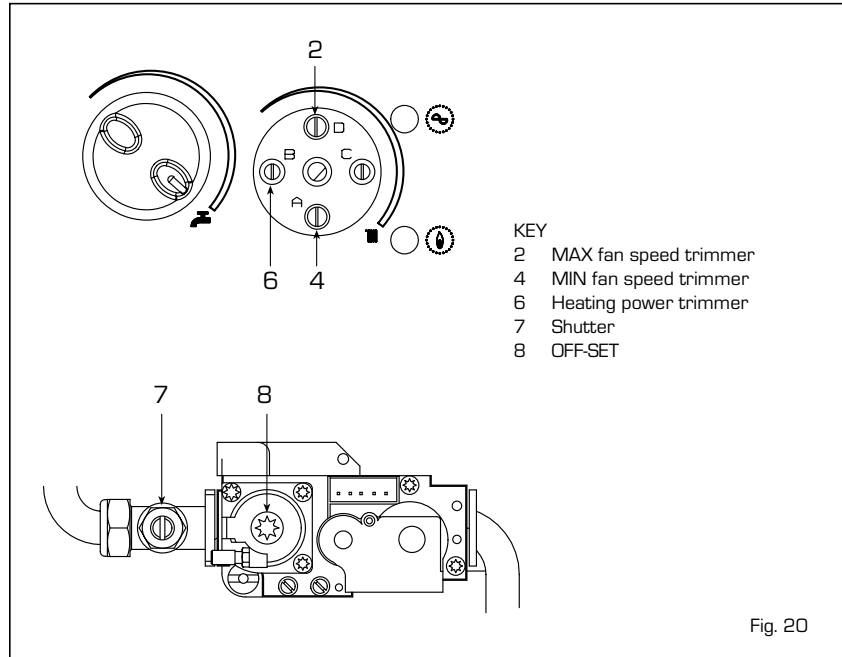

Fig. 20

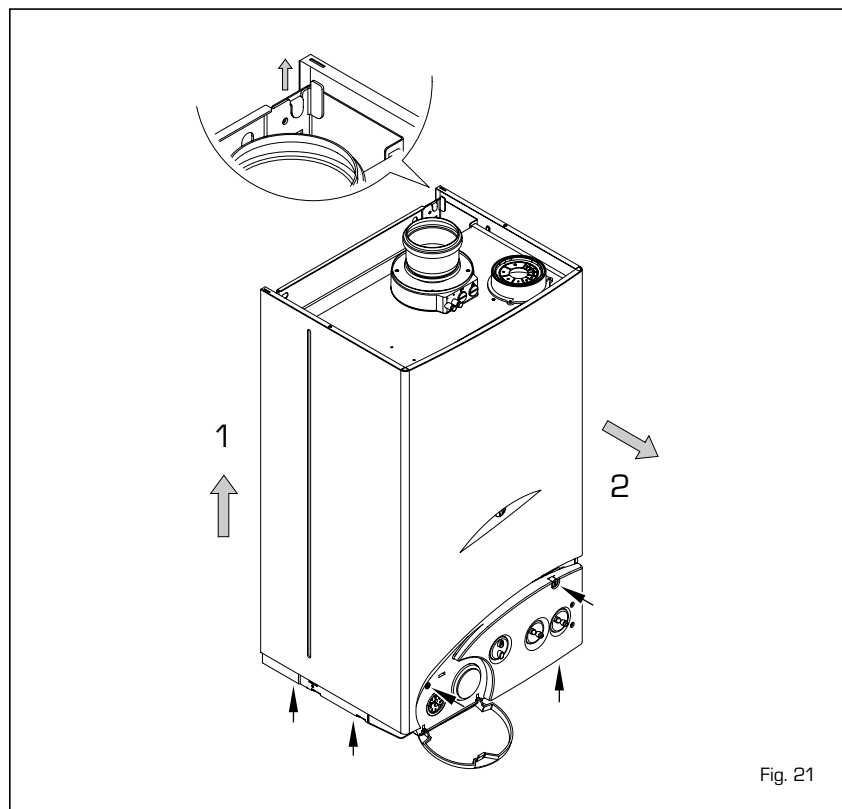

Fig. 21

4.8 REMOVAL OF OUTER CASING

It is possible to completely disassemble the shell for an easy maintenance of the boiler as showed in fig. 21.

4.9 CLEANING AND MAINTENANCE

Preventive maintenance and checking of

efficient operation of equipment and safety devices must be carried out exclusively by authorized technical personnel.

4.10 CLEANING THE C.H. WATER FILTER "AQUA GUARD" (fig. 22)

To clean the filter, close the flow/return valves, turn off the power to the control panel, remove the casing and empty the boiler using the drain provided until the hydrome-

ter shows "zero". Place a container for collection underneath the filter; unscrew the cap and proceed to clean the filter, removing impurities and limestone deposits. Check the seal o-ring before reassembling the cap with the filter.

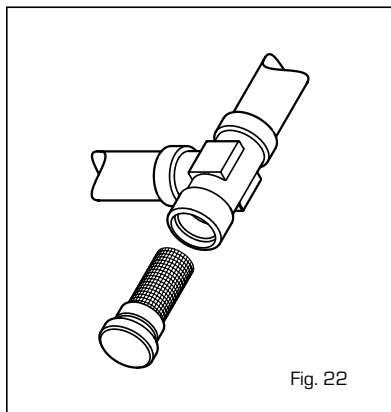

Fig. 22

4.11 CHIMNEY SWEEP FUNCTION (fig. 23)

To carry out the verification of combustion in the boiler turn the selector and stop on the position (0) until the green/orange led starts to flash intermittently.

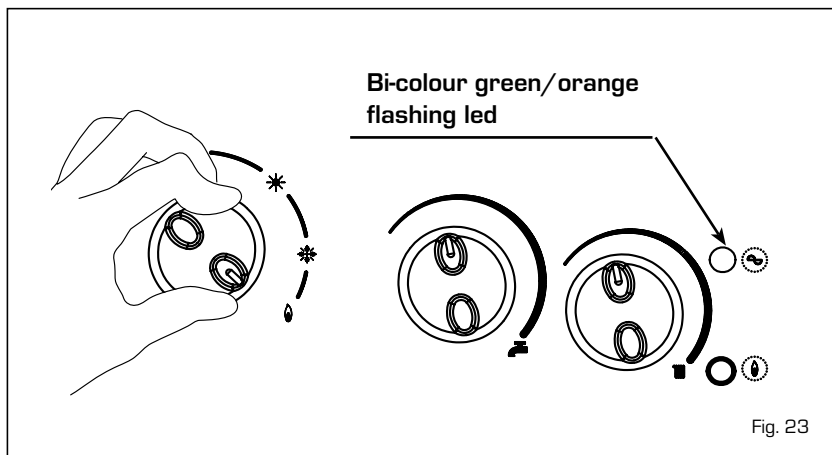

Fig. 23

From that moment the boiler will start functioning in heating mode at the maximum power, with switching off at 80°C and restarting at 70°C.

Before activating the chimney sweep function make sure that the radiator valves or eventual zone valves are open.

The test may be carried out also during hot-water service functioning.

To do so it is enough, after having activated the chimney sweep function, to take some hot water from one or more cocks.

Even in this condition the boiler functions at

the maximum temperature always with the primary controlled between 80°C and 70°C. During the entire duration of the testing the hot water taps must remain open.

After verifying the combustion the boiler should be switched off by placing the selector on the **OFF** position; then return the selector to the desired function.

ATTENTION: After about 15 minutes, or once the hot water request has been fulfilled, the chimney sweep function automatically deactivates.

5 FAULT FINDING

If an electrical fault occurs on the appliance the preliminary electrical system checks contained in the British Gas Multimeter Instruction Booklet must be carried out first. When any service or replacement of electrical components which has required the breaking and re-making of electrical connections has taken place, the following tests must be repeated:

- earth continuity;
- short circuit;
- polarity;
- resistance to earth.

5.1 EARTH CONTINUITY CHECK

Appliances must be electrically disconnected, meter set on Ω (ohm) x 1 scale and adjust zero if necessary. Tests leads from any appliance earth point (e.g. inside control box) see wiring diagrams (section 7) to earth pin on plug. Resistance should be less than 1 Ω (ohm). If the resistance is greater than 1 Ω (ohm) check all earth wires for continuity and all contacts are clean and tight. If the resistance to earth is still greater than 1 Ω (ohm) then this should be investigated further.

5.2 SHORT CIRCUIT CHECK

Switches turned FULL ON - meter set on Ω (ohms) x 1 scale. Test leads from L to N on appliance terminal block, if meter reads 0 then there is a short circuit.

Meter set on Ω (ohm) x 100 scale. Repeat it with leads from L to E. If meter reads less than infinity (∞) there is a fault.

NOTE: Should it be found that the fuse has failed but no fault is indicated, a detailed continuity check (i.e. by disconnecting and checking each component) is required to trace the faulty component.

It is possible that a fault could occur as a result of local burning/ arcing but no fault could be found under test. However, a detailed visual inspection should reveal evidence of burning around the fault.

5.3 POLARITY CHECK

Appliance reconnected to mains supply and meter set on 300 V ac scale. Test at appliance terminal block.

- Test leads from L to N meter reads

approx.: 240 V ac.

- Test leads from L to E " * " meter reads approx. 240 V ac.
- Test leads from N to E " * " meter reads from 0 to 15 V ac.

5.4 RESISTANCE TO EARTH CHECK

Appliance must be disconnected from main supply and meter on Ω (ohm) x 100 scale. All switches including thermostat on test leads from L to E - if meter reads other than infinity (∞) there is a fault which should be isolated.

A detailed continuity check is required to trace the faulty component.

IMPORTANT:

These series of checks are the first electrical checks to be carried out during a fault finding procedure. On completion of the service/fault finding task which has required the breaking and remaking of electrical connections then the checks 5.1 Earth continuity, 5.3 Polarity and 5.4 Resistance to earth must be repeated.

5.5 C.H. MODE - FAULT FINDING

Start from cold
 Rotary switch set to WINTER position.
 Room thermostat (if fitted) calling for heat and all D.H.W. taps off.
 C.H. thermostat set to maximum position.
 Clock in the on position (if fitted).

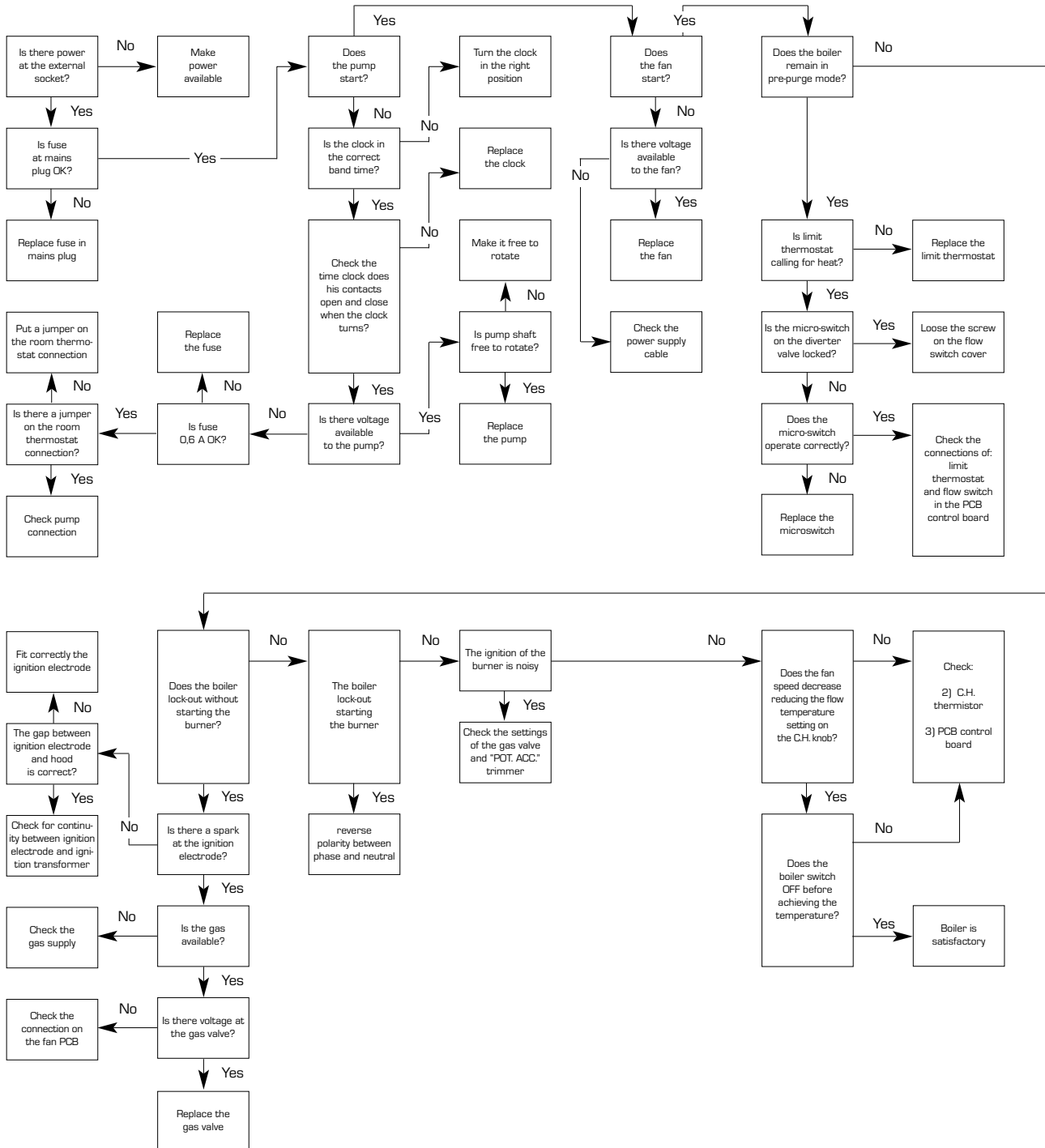

NOTE:

After completing fault finding reset the room thermostat (if fitted) to the required setting. If the appliance will not function check the wiring to the clock and if necessary, replace the clock.

5.6 D.H.W. MODE - FAULT FINDING

Start from cold - rotary switch set to SUMMER position, D.H.W. thermostat set to maximum, and all D.H.W. taps OFF.

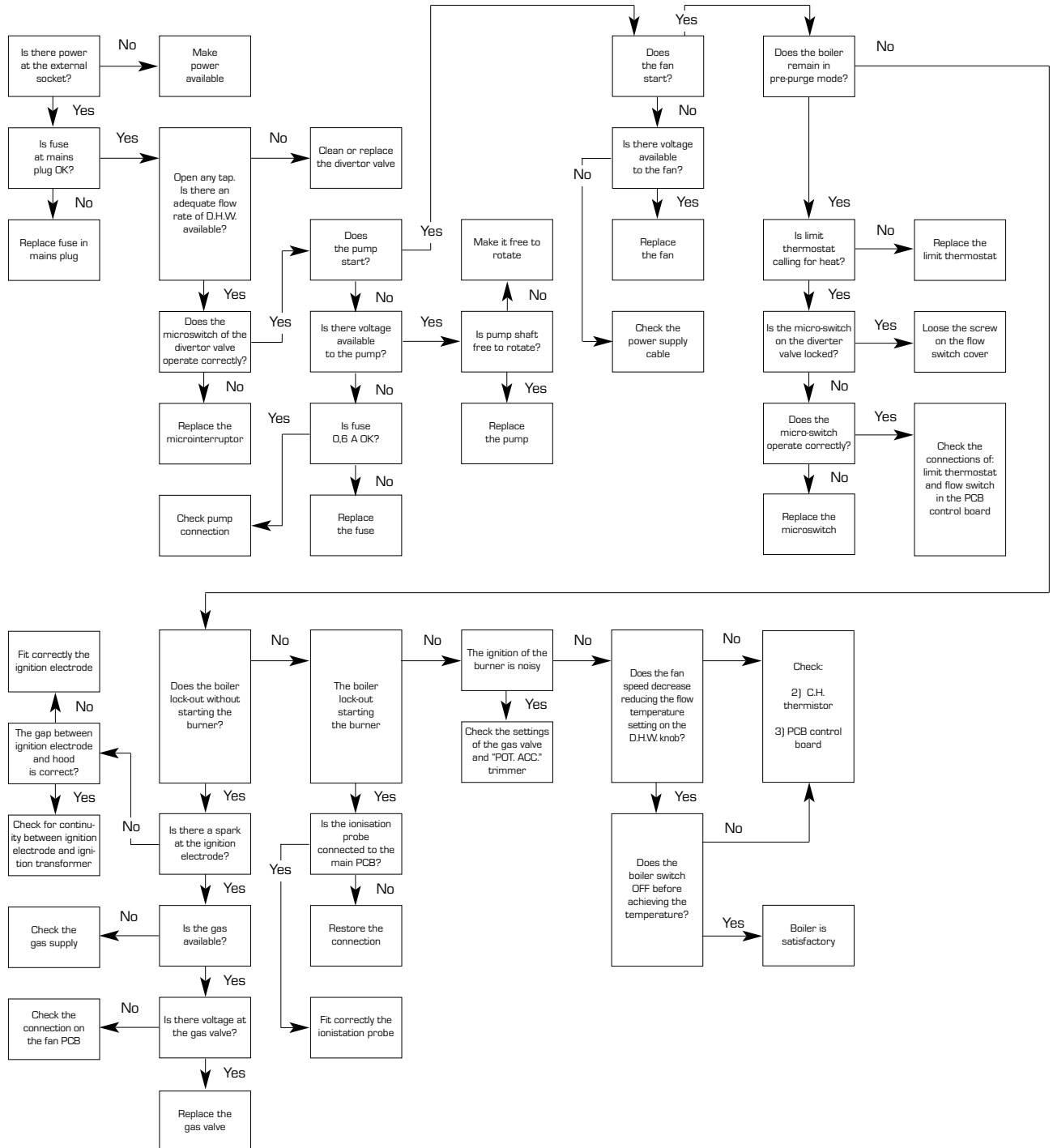

NOTE:

When commissioning the boiler, please check the polarity in case the pump and the fan are running but the burner does not fire.

6 REPLACEMENT OF PARTS

6.1 EXPANSION VESSEL

- Turn off power supply
- Remove boiler cover
- Isolate flow and return valve
- Drain boiler using fitted drain vent
- Disconnect expansion pipe
- Loosen top fixing screw and remove lower fixing screw
- Remove vessel
- Check new vessel for correct pressure 1-1.25 bar
- Refit in reverse order.

6.2 IGNITION/IONISATION ELECTRODE

- Turn off power supply
- Remove boiler cover
- Remove sealed cover
- Disconnect electrode from ignition transformer
- Pull lead through grommet
- Remove electrode fixing screw
- Replace in reverse order.

6.3 MAIN BURNER

- Turn off power supply
- Isolate gas supply
- Remove boiler cover
- Remove sealed chamber cover
- Disconnect gas connection at injector
- Disconnect air sensing tube
- Disconnect two plugs to fan
- Remove ignition/ionisation electrode as described in 6.2
- Remove 6 x 10 mm nuts securing burner to heat exchanger
- Carefully lift out burner assembly
- Refit in reverse order
- Test for gas soundness.

6.4 FAN ASSEMBLY

- Remove burner assembly as described in 6.3
- Remove 4 x 8 mm bolts securing fan to burner assembly
- Refit in reverse ensuring injector assembly is fitted with arrow pointing from fan to burner
- Recommission boiler
- Test for gas soundness.

6.5 MAIN HEAT EXCHANGER

- Turn off power supply
- Isolate gas supply
- Isolate flow and return valves
- Drain boiler using drain vent
- Remove burner assembly as described in 6.3
- Remove flue connection
- Disconnect 95° stat
- Disconnect 90° stat
- Remove condensate drain connections

- Remove upper auto air vent
- Disconnect flow and return connections
- Remove two fixing brackets
- Lift out heat exchanger
- Refit in reverse order
- Recommission boiler
- Test for gas soundness:

6.6 95° SMOKE STAT

- Turn off power supply
- Remove boiler cover
- Remove sealed chamber cover
- Disconnect 95° stat
- Unscrew from smoke chamber
- Refit in reverse order.

6.7 90° LIMIT STAT

- Turn off power supply
- Remove cover
- Remove sealed chamber cover
- Disconnect 90° stat
- Unscrew stat
- Replace in reverse order.

6.8 100° SAFETY STAT

- Turn off power supply
- Remove cover
- Remove sealed chamber cover
- Disconnect 100° safety stat
- Remove fixing screws
- Refit in reverse order.

6.9 THERMISTOR (SM SENSOR)

- Turn off power supply
- Remove cover
- Isolate flow and return valves
- Drain boiler using drain vent
- Disconnect thermistor
- Unscrew thermistor (catch any water lost)
- Refit in reverse.

6.10 GAS VALVE

- Turn off power supply
- Isolate gas supply
- Remove boiler cover
- Disconnect wiring from gas valve
- Disconnect sensing tube
- Remove gas valve complete with gas shutter
- Split gas shutter from gas valve
- Refit in reverse order ensuring seals are replaced as required
- Recommission boiler
- Check for gas soundness.

6.11 GAS SHUTTER

- As gas valve 6.10.

6.12 PRINTED CIRCUIT BOARD (PCB)

- Isolate from power supply
- Remove screws securing control panel
- Lower panel to horizontal position
- Remove PCB cover
- Disconnect all wiring
- Remove heat control knobs
- Remove PCB fixing screws
- Transfer trimmer spindles to new board
- Ensure PCB links are matched to old board
- Refit in reverse order
- Recommission boiler.

6.13 PUMP MOTOR

- Turn off power supply
- Remove boiler cover
- Isolate flow and return valves
- Drain boiler using drain vent
- Remove plug connection
- Remove 4 x fixing screws, catch any lost water
- Refit in reverse using new gasket.

6.14 DIVERTER VALVE MICROSWITCH

- Turn off power supply
- Remove boiler cover
- Pull off microswitch in direction of wiring
- Refit in reverse.

6.15 DOMESTIC HOT WATER HEAT EXCHANGER

- Turn off power supply
- Isolate flow and return
- Turn on DHW tap
- Close cold water supply isolation valve
- Drain boiler using drain vent
- Remove diverter valve microswitch as described in 6.14
- Remove microswitch actuator from top of diverter valve
- Remove 3 x heat exchanger fixing screws
- Remove plate heat exchanger, catch any water lost
- Ensure that the four "O" rings are removed from the technical assembly
- Fit the new "O" ring supplied with the new heat exchanger to the heat exchanger
- Refit in reverse order.

6.16 DIVERTER VALVE

- Remove diverter valve microswitch as described in 6.14
- Remove plate heat exchanger as described in 6.15
- Remove plug securing clip at RHS of diverter assembly. NOTE: a internal spring will push off the plug. Retain.
- Remove internal bush from spindle
- Remove diverter valve head securing

-
- clip
 - Pull diverter valve head from assembly
 - Remove spindle from assembly complete with bush and spacer
 - Replace in reverse order replacing "O" rings as required.

6.17 TOP AUTO AIR VENT (AAV)

- Turn off power supply
- Isolate flow and return valves
- Drain boiler using drain vent
- Unscrew AAV
- Refit in reverse.

6.18 INTERNAL AUTO AIR VENT (AAV)

- Turn off power supply
- Isolate flow and return valves
- Remove boiler cover

- Drain boiler using drain vent
- Remove AAV
- Replace in reverse order.

6.19 SAFETY VALVE

- Turn off power supply
- Isolate flow and return valves
- Remove boiler cover
- Drain boiler using drain vent
- Disconnect pipe from safety valve
- Remove safety valve securing clip
- Remove safety valve, catch any water lost
- Refit in reverse.

6.20 PRESSURE/TEMPERATURE GAUGE

- Turn off power supply
- Isolate flow and return valves

- Remove boiler cover
- Drain boiler using drain vent
- Remove the clip securing the pressure sensor
- Remove the clip securing thermometer bulb
- Carefully remove the gauge
- Refit in reverse order.

7 EXPLODED VIEWS

7.1 HYDRAULIC CIRCUIT

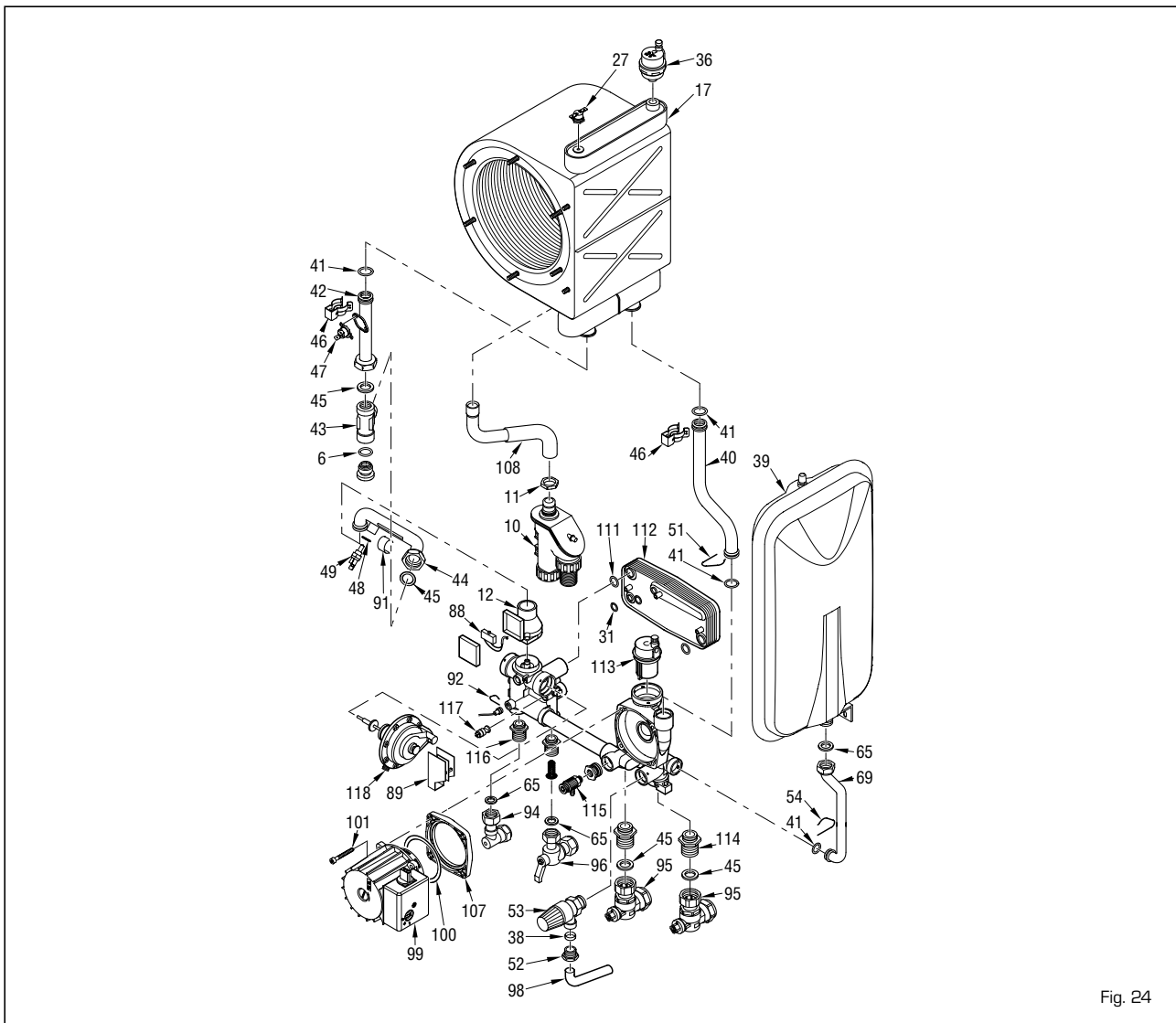

Fig. 24

Position	Code	Description
6	6226429	O-ring 121
10	6277202	Water trap
11	6146301	Brass nut 1/2"
12	6281513	Flow water switch spare parts
17	6278906	Main exchanger body
27	6146721	Limit stat
31	• 6226414	O-ring 117 Ø 13,1x2,62 EP851
36	6013102	Automatic air vent 1/4"
38	6100202	Ogive for pipe Ø 15
39	5183711	Rectang. expansion vessel 8 l. 1/2" M
40	6227418	Heat exchanger outlet pipe
41	• 6226412	O-ring 3068
42	6277712	Pipe connect. exchanger-C.H filter
43	6295500	C.H. filter 3/4" M x 3/4" M
44	6277711	Pipe connect. C.H. filter-C.H. flow
45	2030228	Gasket Ø 17x24x2
46	• 6226601	Spring for heat exchanger connection
47	• 6146701	100°C safety stat
48	• 6022010	Sensor gasket
49	• 6231351	Plunged sensor
51	6226607	Pipe fixing spring
52	6168401	Locking nut for pipe Ø 15
53	• 6040201	Pressure relief valve
54	• 6226602	Pipe fixing spring

Position	Code	Description
65	2030227	Gasket Ø 12x18x2
69	6227652	Pipe connecting expansion vessel
88	• 6131401	Microswitch for flowmeter
89	5191900	Divertor valve microswitch + support
91	2051100	Retaining spring
92	6226605	Fixing spring
94	6142330	Quarter bend 1/2" x 15
95	6177505	Ball cock 3/4" x 22
96	6177506	Ball cock 1/2" x 15
98	6157602	Pressure relief valve drain pipe
99	6272304	Circulating pump VA 65 Dab motor
100	• 6028705	Gasket EP709 for Dab
101	2000201	Screw M5x40
107	6281521	Flange + OR for Dab pump
108	6034152	Condensate drainage rubber pipe
111	6226421	O-ring Dalmar R12
112	6281522	14 plate heat exchanger kit
113	• 6013101	Automatic air vent
114	6281500	Straight fitting 3/4"
115	• 6017210	Manual air vent 1/4"
116	6281501	Straight fitting 1/2"
117	6281512	Water rate adjuster
118	• 6281504	Divertor valve

7.2 COMBUSTION CIRCUIT

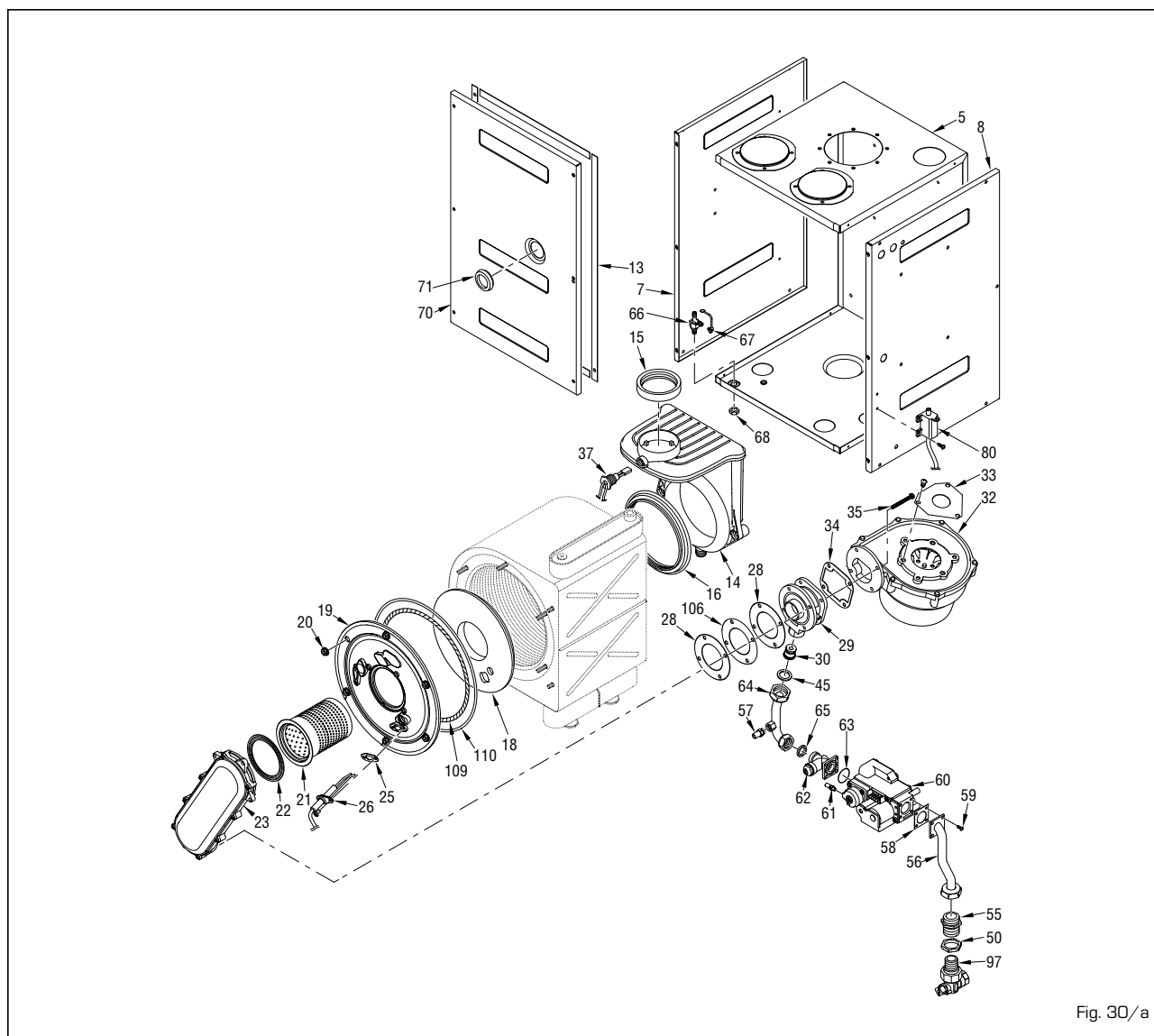

Fig. 30/a

Position	Code	Description	Position	Code	Description
5	6266037	Sealed chamber rear panel	45	2030228	Gasket Ø 17x24x2
7	6266122	Sealed chamber left hand side panel	50	6146302	Brass nut 3/4"
8	6266123	Sealed chamber right hand side panel	55	6120515	Straight fitting 3/4"
13	5192200	Gasket for sealed chamber	56	6226861	Gas inlet pipe
14	6278701	Smoke chamber	57	6023100	Pressure test nipple Ø 1/8"
15	6248851	Smoke chamber outlet gasket	58	• 6162401	Square gasket
16	6248852	Smoke chamber/exchanger gasket	59	2000710	Screw TCB M4x10 Zn
18	6269006	Combustion chamber door insulation	60	6243821	Honeywell gas valve type VK4115V
19	6278851	Main exchanger door	61	6235802	Pressure test point M5
20	2010183	Nut for exchanger flange	62	6216607	Gas shutter 1/2"
21	6278305	Premix burner	63	• 6226407	O-ring 130 ø 22,22x2,62 XP70
22	6174817	Gasket for burner flange	64	6277403	Pipe connecting gas valve-mixer
23	6278802	Air-gas hose	65	2030227	Gasket Ø 12x18x2
25	6174809	Gasket for ignition electrode	66	6280500	3-ways junct. with press. test nipple
26	6221625	Ignition-ionisation electrode	67	6280550	Cap for 3-ways junction
28	6174812	Mixer/hose gasket	68	6146303	Brass Nut 1/8"
29	6274307	Air/gas mixer	70	6228847	Sealed chamber front panel
30	6274124	Burner nozzle ø 7,00 natural gas	71	6001210	Peephole
32	6261403	Fan RG128/ 1300-3612	80	• 6098304	Ignition transformer
33	6028642	Air diaphragm	97	6177504	Gas cock 1/2" x 1/2"
34	6174816	Gasket for fan flange	106	6239206	Mixer closing plate
35	2000507	Screw TE M5x50	109	6278968	Glass fibre sealing cord
37	5191990	Smoke stat kit	110	6278967	Combustion chamber O-ring

7.3 STRUCTURAL COMPONENTS AND CONTROL & REGULATIONS

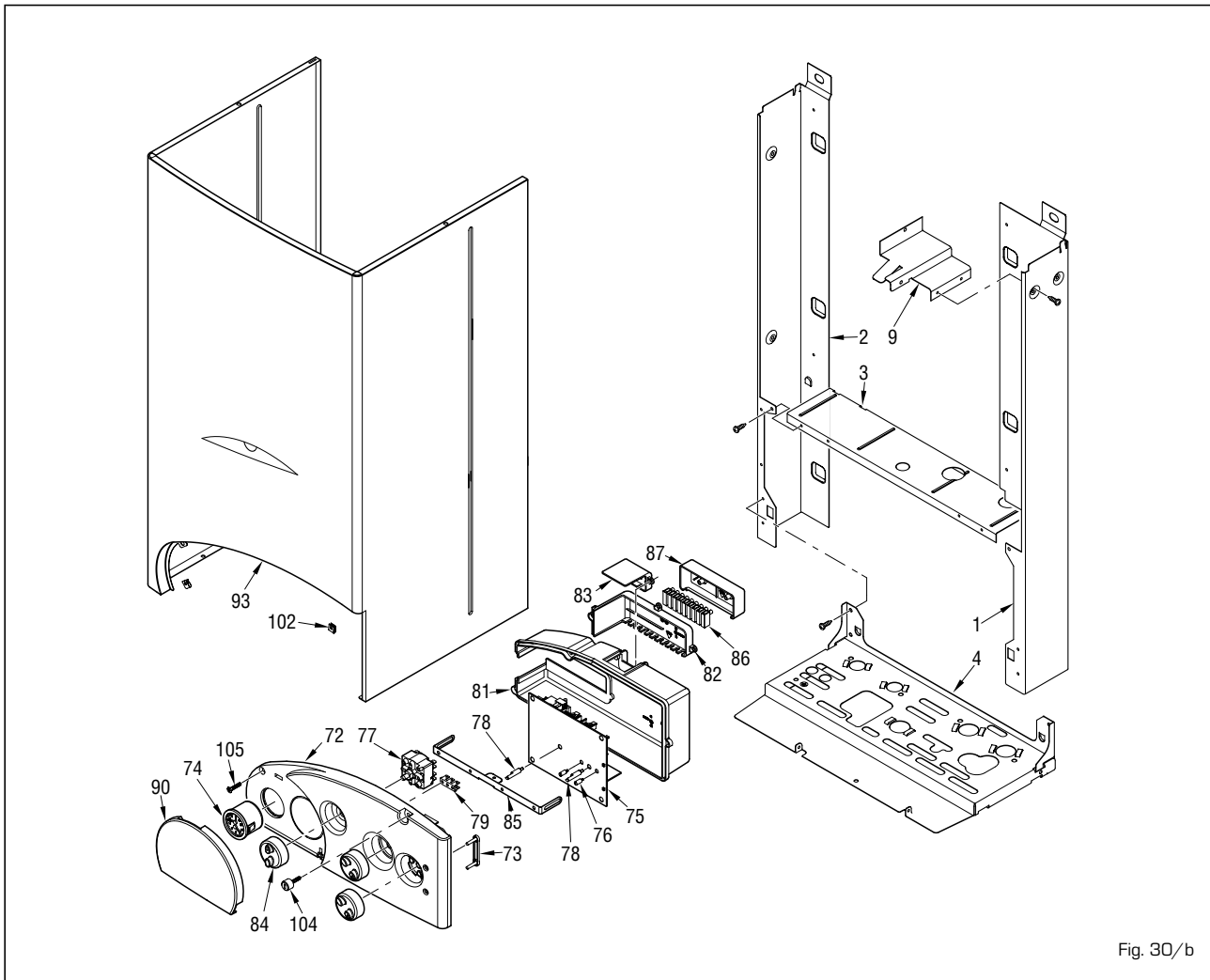

Fig. 30/b

Position	Code	Description
1	6138532	Right hand side frame part
2	6138632	Left hand side frame part
3	6255430	Expansion vessel lower support
4	6138870	Frame assembly lower side
9	6189543	Expansion vessel supporting bracket
72	6289803	Control panel
73	6273210	Guidelight - 2 ways out
74	6217005	Temperature and pressure gauge
75	6230692	Main PCB with ignition
76	• 6201501	Trimmer spindle Ø 5
77	• 6260701	Rotary switch
78	• 6201505	Trimmer spindle Ø 6
79	2211610	Earth faston

Position	Code	Description
81	6289900	Control panel protecting cover
82	6290300	Control panel cable cover
83	6290202	Room stat cover
84	6290100	White knob Ø 40
85	6009585	Control panel bracket
86	2211004	Terminal strip
87	6290350	Terminal strip protection cover
90	6290010	Flap door
93	6287323	Casing
102	• 2013302	Fastener for self tapping screw
104	6112420	Control panel screw
105	2004510	Screw 8Px7/8"



Sime Ltd

Unit D2 Enterprise Way, Bradford Road, Bradford, West Yorkshire, BD10 8EW

Tel. 0870 9911114 - Fax 0870 9911115

www.sime.ltd.uk - e-mail: enquiries@sime.ltd.uk

PLEASE LEAVE THIS INSTRUCTION
WITH THE USER

GB

Format 30 HE

User instructions



*The code of practice for the installation,
commissioning & servicing for central heating systems*

WRAS
APPROVED
PRODUCT



CONTENTS

OPERATING INSTRUCTIONS FOR THE USER

1.1	INTRODUCTION	2
1.2	APPLIANCE OPERATION	
1.3	OPERATING INSTRUCTIONS	
1.4	MINIMUM CLEARANCES	3
1.5	ROUTINE SERVICING	
1.6	GENERAL INFORMATION	
1.7	SAFETY	4

These appliances comply with the S.E.D.B.U.K. scheme, band "D"

VERY IMPORTANT!

**PLEASE MAKE SURE YOUR LOG BOOK ENCLOSED IS FILLED IN CORRECTLY.
ALL CORGI REGISTERED INSTALLERS CARRY A CORGI ID CARD.
BOTH SHOULD BE RECORDED IN YOUR CENTRAL HEATING LOG BOOK.
YOU CAN CHECK YOUR INSTALLER IS CORGI REGISTERED
BY CALLING ON 01256 372300**

OPERATING INSTRUCTIONS FOR THE USER

THE GAS SAFETY (INSTALLATION AND USE) REGULATIONS 1996. It is the law that all gas appliances are installed by a registered person, in accordance with the above regulations. Failure to install appliances correctly could lead to prosecution. It is in your own interest, and that of safety, to ensure that the law is complied with.

It is essential that the appliance is correctly earthed. An electricity supply of 240 V - 50 Hz fused at 3 A is required.

Read these instructions carefully before attempting to operate the appliance.

1.1 INTRODUCTION

The Sime "FORMAT 30 HE" family is a fully automatic, wall mounted, room sealed, fan assisted range of combination boilers. When operating in winter mode, the appliance provides central heating as required and produces instantaneous hot water upon demand.

When operating in summer mode, the central heating is not operational however the appliance continues to supply hot water whenever it is required. The heat output is automatically controlled by the fully modulating gas valve (within its preset limits), and there are user adjustable potentiometers to control the temperature of both central heating and domestic hot water. A temperature/pressure gauge is fitted and an overheat thermostat is incorporated to protect against fault conditions.

1.2 APPLIANCE OPERATION

A demand of hot water will be sensed by the appliance detecting water flow (providing that the flow rate is above 2 l/m - 0.5 gal/min).

The fan will start and the burner will light at full output. If

the draw off rate is near the maximum design flow rate the appliance will run continuously at full output until a tap is either turned off or the flow rate is reduced in which case the heat output will reduce accordingly to maintain a steady temperature.

Hot water is made available almost immediately at the appliance outlet, but the final temperature and time taken for the hot water to reach a tap depends upon the potentiometer setting, the rate at which water is drawn off, and the length of the pipe between the boiler and the tap.

When the tap is turned off, the appliance will revert to C.H. mode (if set on winter position) otherwise the burner will be extinguished pending the next demand for hot water.

1.3 OPERATING INSTRUCTIONS

1.3.1 To light the appliance (see fig. 1)

- Check that the electricity supply is off and that the D.H.W. isolation valve is in the open position (lever vertical). Check that the gas supply is on.
- Turn the selector switch summer/winter (C) to SUMMER (water only) position "☀".
- Switch on the electricity supply and full open any D.H.W. tap. The burner will light.
Check that the burner has lit by looking through the viewing window (F). If the burner fails to light, turn the selector switch summer/winter to "🔥" position and release it immediately; then turn it to the SUMMER position: the burner should now light. Turn off the tap.
- Check that the room thermostat and time clock are calling for heat. Turn the heating potentiometer (D) to maximum (fully clockwise).
- Turn the selector switch summer/winter to the WINTER position "❄" and the burner will light to serve the heating load.

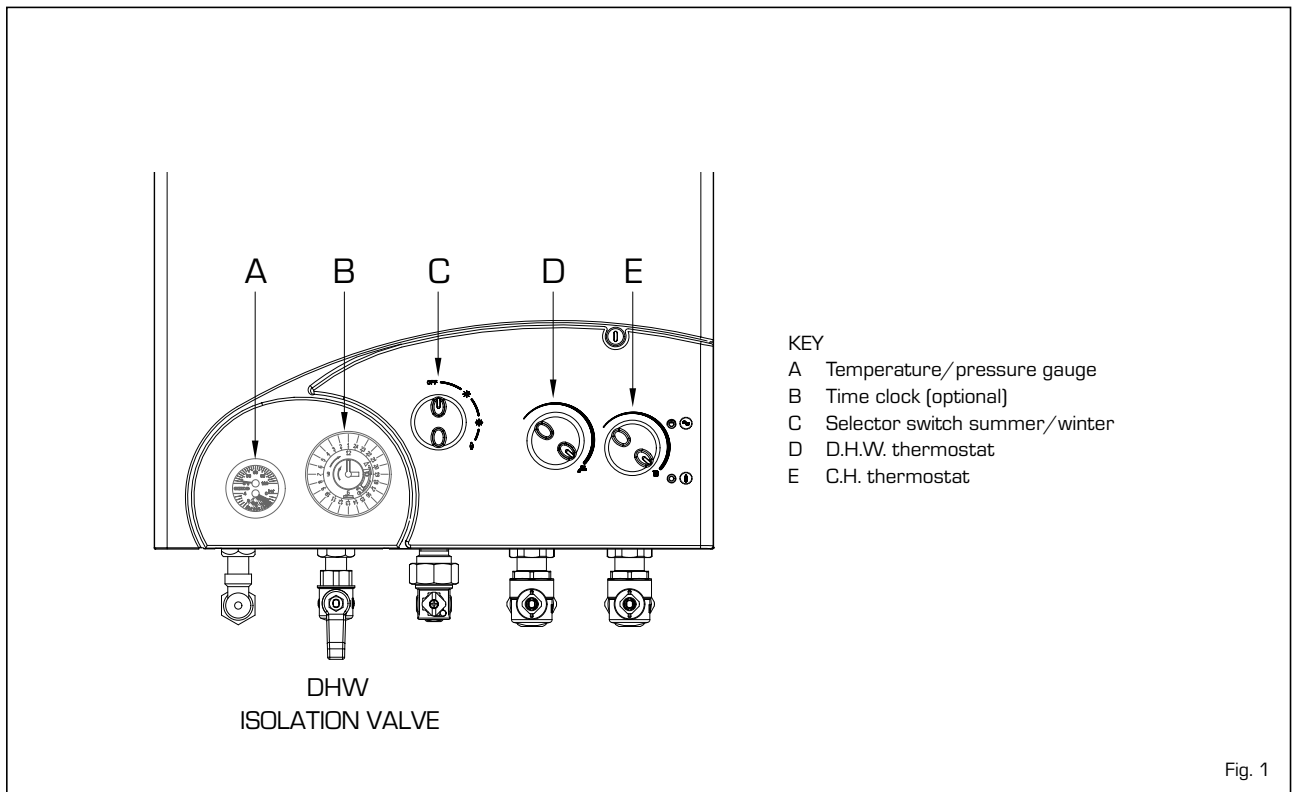

Set the required temperature for the C.H. and D.H.W. by rotating the potentiometers (D - E) clockwise to increase or anticlockwise to decrease the temperature.

NOTE: when operating in winter mode, priority is automatically given to providing hot water when the demand arises.

1.3.2 To turn off the appliance (see fig. 1)

- For short periods:

Set the selector switch (C) to the OFF position and urn off the DHW Isolation valve. When required, restore turn the selector switch to either the SUMMER or WINTER position and turn on the DHW Isolation valve.

- For longer periods:

Set the selector switch (C) to the OFF position, turn off the DHW Isolation valve, turn off the gas isolation cock. When required, manually rotate the pump, open the gas isolation cock, turn on the DHW Isolation valve and turn the selector switch to either the SUMMER or WINTER position.

NOTE: If frost protection is required-turn the selector switch to the summer position, do not isolate the gas supply, turn off the DHW Isolation valve.

1.4 MINIMUM CLEARANCES

The following MINIMUM CLEARANCES must be available for

servicing the appliance:

	For ventilation	For servicing
ABOVE THE APPLIANCE CASING	200 mm	300 mm
AT THE R.H.S.	15 mm	15 mm
AT THE L.H.S.	15 mm	15 mm
BELOW THE APPLIANCE CASING	200 mm	200 mm
IN FRONT OF THE APPLIANCE	350 mm	500 mm

1.5 ROUTINE SERVICING

To ensure continued efficient operation of the appliance, it is recommended that it is checked and serviced as necessary at regular intervals.

The frequency of servicing will depend upon the particular installation conditions and usage but in general once a year should be adequate. It is the law that any service work must be carried out by a registered person (C.O.R.G.I.).

1.6 GENERAL INFORMATION

1.6.1 Fault finding indicators (LEDS)

The appliance is fitted with a safety cut-out thermostat. In the event of overheating this will interrupt the power supply and prevent the appliance from functioning.

If this occurs, allow the appliance to cool, turn the selector switch summer/winter to "⬇️" position and release it immediately, then turn it back to the previous position (see fig. 2).

If the cut-out condition is repeated, turn off the electrical supply and consult your installer or service engineer.

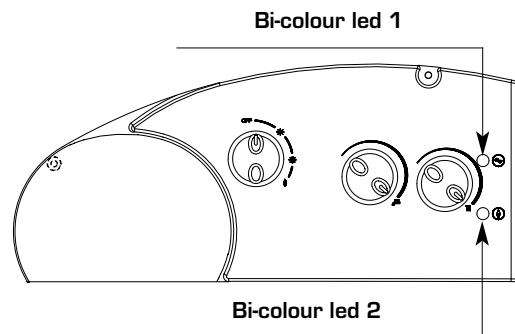

Operating mode	Bi-colour led 1	Bi-colour led 2
Stand-by	green ON	OFF
Flame presence	green ON	orange ON
Flame detection circuit fault	green ON	flashing orange
Ignition lock	OFF	red ON
Water flow switch (FL) or limit stat (TL) intervention	flashing orange	OFF
Fan fault	flashing green	OFF
C.H. sensor (SM) fault	steady orange	OFF
Boiler off	OFF	OFF

Fig. 2

1.6.2 Temperature/pressure gauge

The gauge [A fig. 1] on the fascia panel indicates the approximate system pressure. If the normal running pressure is seen to decrease over a period of time there is a water leak and you should consult your installer or service engineer.

1.6.3 Electrical supply

The mains plug used must be a 3 pin type to BS1363, and fused at 3 A. THIS APPLIANCE MUST BE EARTHED.

NOTE:

an interruption in the electricity supply whilst the burner is alight may cause the overheat thermostat to operate. If this is suspected, turn the rotary switch to “0” position and release it immediately, then turn it back to the previous position.

TO CONNECT A PLUG

As the colour of wires in the mains lead of this appliance may not correspond with the coloured markings identifying the terminals in your plug, proceed as follows:

the wire which is coloured green and yellow must be connected to the terminal in the plug which is marked with the letter E or by the earth symbol - or coloured green and yellow; the wire which is coloured blue must be connected to the terminal marked with the letter N or coloured black; the wire which is coloured brown must be connected to the terminal marked with the letter L or coloured red.

1.6.4 Ventilation

If the appliance is installed in a cabinet, the latter MUST NOT be used for storage purposes. Any ventilation provided for the appliance during installation MUST NOT be blocked and a periodic check must be made to ensure that the vents are free from obstructions.

1.6.5 Cleaning

Use only a damp cloth and mild detergent to clean the appliance outer casing. DO NOT use abrasive cleaners.

1.7 SAFETY

It is essential that the instructions in this booklet are strictly followed for the safe and economical operation of this appliance. The appliance functions as a fan assisted balanced flue unit. The flue terminal MUST NOT BE OBSTRUCTED under any circumstances. If damaged, turn off the appliance and consult the installer, service engineer, or gas supplier. If it is known or suspected that a fault exists on the appliance it MUST NOT be used until the fault has been rectified by a competent person.

WARNING: IF A GAS LEAK IS SUSPECTED OR EXISTS, TURN OFF THE GAS SUPPLY TO THE APPLIANCE AT THE GAS SERVICE COCK. DO NOT OPERATE ANY ELECTRICAL SWITCHES. DO NOT OPERATE ANY ELECTRICAL APPLIANCE. OPEN ALL WINDOWS AND DOORS. DO NOT SMOKE. EXTINGUISH ALL NAKED LIGHTS. CONTACT THE GAS SUPPLIER IMMEDIATELY.



Sime Ltd

Unit D2 Enterprise Way, Bradford Road, Bradford, West Yorkshire, BD10 8EW

Tel. 0870 9911114 - Fax 0870 9911115

www.sime.ltd.uk - e-mail: enquiries@sime.ltd.uk