

MURELLE EV HE 25/55 - 30/55

USER INSTRUCTIONS



ENSURE THAT THESE INSTRUCTIONS ARE LEFT FOR THE USER AFTER COMPLETION OF THE BENCHMARK SECTION

PLEASE READ THE IMPORTANT NOTICE WITHIN THIS GUIDE REGARDING YOUR BOILER WARRANTY



IMPORTANT NOTICE

For the first year all of our appliances are protected by our manufacturer's guarantee which covers both parts and labour.

As you would expect from Sime Ltd, it is our aim to provide our valued customers with the best in after sales and service.

To take advantage of any extended warranty offered, all you have to do is to adhere to these 3 simple conditions:

- The installation must be carried out to Manufacturers/Benchmark Standards by a Gas Safe Registered Engineer, and recorded in the installation manual.
- The appliance must be registered with both Sime Ltd and Gas Safe within 30 days of installation.
- The appliance must be serviced annually, by either Sime Ltd or a Gas Safe registered engineer- ensuring that the Benchmark service record in the installation manual is completed.

Failure to comply with the above will result in only the 12 month warranty being offered.

In the absence of any proof of purchase, the 12 month warranty period will commence from the date of manufacture of the boiler as shown on the appliance data plate.

Code Of Practice

For the installation, commissioning and servicing
of domestic heating and hot water products

Benchmark places responsibilities on both manufacturers and installers.* The purpose is to ensure that customers** are provided with the correct equipment for their needs, that it is installed, commissioned and serviced in accordance with the manufacturer's instructions by competent persons and that it meets the requirements of the appropriate Building Regulations. Installers are required to carry out work in accordance with the following:

Standards of Work

- Be competent and qualified to undertake the work required.
- Install, commission, service and use products in accordance with the manufacturer's instructions provided.
- Ensure that where there is responsibility for design work, the installation is correctly sized and fit for purpose.
- Meet the requirements of the appropriate Building Regulations. Where this involves notifiable work be a member of a Competent Persons Scheme or confirm that the customer has notified Local Authority Building Control (LABC), prior to work commencing.
- Complete all relevant sections of the Benchmark Checklist/Service Record when carrying out commissioning or servicing of a product or system.
- Ensure that the product or system is left in a safe condition and, whenever possible, in good working order.
- Highlight to the customer any remedial or improvement work identified during the course of commissioning or servicing work.
- Refer to the manufacturer's helpline where assistance is needed.
- Report product faults and concerns to the manufacturer in a timely manner.

Customer Service

- Show the customer any identity card that is relevant to the work being carried out prior to commencement or on request.
- Give a full and clear explanation/demonstration of the product or system and its operation to the customer.
- Hand over the manufacturer's instructions, including the Benchmark Checklist, to the customer on completion of an installation.
- Obtain the customer's signature, on the Benchmark Checklist, to confirm satisfactory demonstration and receipt of manufacturer's instructions.
- Advise the customer that regular product servicing is needed, in line with manufacturers' recommendations, to ensure that safety and efficiency is maintained.
- Respond promptly to calls from a customer following completion of work, providing advice and assistance by phone and, if necessary, visiting the customer.
- Rectify any installation problems at no cost to the customer during the installer's guarantee period.



*The use of the word "installer" is not limited to installation itself and covers those carrying out installation, commissioning and/or servicing of heating and hot water products, or the use of supporting products (such as water treatment or test equipment).

**Customer includes householders, landlords and tenants.

The Benchmark Scheme

Sime Ltd is a licensed member of the Benchmark Scheme which aims to improve the standards of installation and commissioning of domestic heating and hot water systems in the UK and to encourage regular servicing to optimise safety, efficiency and performance.

Benchmark is managed and promoted by the Heating and Hotwater Industry Council.
For more information visit www.centralheating.co.uk

Please ensure that the installer has fully completed the Benchmark Checklist on the inside back pages of the installation instructions supplied with the product and that you have signed it to say that you have received a full and clear explanation of its operation.

The installer is legally required to complete a commissioning checklist as a means of complying with the appropriate Building Regulations (England and Wales).

All installations must be notified to Local Area Building Control either directly or through a Competent Persons Scheme.

A Building Regulations Compliance Certificate will then be issued to the customer who should, on receipt, write the Notification Number on the Benchmark Checklist.

This product should be serviced regularly to optimise its safety, efficiency and performance.

The service engineer should complete the relevant Service Record on the Benchmark Checklist after each service.

The Benchmark Checklist may be required in the event of any warranty work and as supporting documentation relating to home improvements in the optional documents section of the Home Information Pack.

CONTENTS

OPERATING INSTRUCTIONS FOR THE USER

1.1	INTRODUCTION	6
1.2	APPLIANCE OPERATION	
1.3	OPERATING INSTRUCTIONS	
1.4	ERRORS AND SOLUTIONS	9
1.5	MINIMUM CLEARANCES	
1.6	ROUTINE SERVICING	
1.7	ELECTRICAL SUPPLY	10
1.8	VENTILATION	
1.9	SAFETY	
	MECHANICAL TIME CLOCK (CODE 8092228)	11
	DIGITAL TIME CLOCK (CODE 8092229)	12
	ANALOGIC RF TIME PROGRAMMER (CODE 8092231)	13
	DIGITAL RF TIME PROGRAMMER (CODE 8092232)	14



Murelle EV HE 25/55 : Gas Council number 47-283-20

Murelle EV HE 30/55 : Gas Council number 47-283-21

VERY IMPORTANT!

**PLEASE MAKE SURE YOUR BENCHMARK CHECKLIST IN THE
INSTALLATION GUIDE, IS FILLED IN CORRECTLY.**

ALL GAS SAFE REGISTER INSTALLERS CARRY A ID CARD.

**THE REGISTRATION NUMBER SHOULD BE
RECORDED ON THE CHECK LIST.**

**YOU CAN CHECK YOUR INSTALLER IS GAS SAFE
REGISTERED BY CALLING ON 0800 408 5577**

OPERATING INSTRUCTIONS FOR THE USER

THE GAS SAFETY (INSTALLATION AND USE) REGULATIONS 1996. It is the law that all gas appliances are installed by a registered person, in accordance with the above regulations. Failure to install appliances correctly could lead to prosecution. It is in your own interest, and that of safety, to ensure that the law is complied with.

It is essential that the appliance is correctly earthed. An electricity supply of 240 V - 50 Hz fused at 3 A is required. Read these instructions carefully before attempting to operate the appliance.

1.1 INTRODUCTION

The Sime "MURELLE EV HE 25/55 - 30/55" is a fully automatic, wall mounted, room sealed, fan assisted range of combination boilers.

The D.H.W. storage tank allows a variety of requests to be met thanks to the abundance of water.

When operating in summer mode, the central heating is not operational however the appliance continues to supply hot water whenever it is required.

1.2 APPLIANCE OPERATION

Priority is given to the domestic hot water unless this is on a separate time control.

On demand, domestic hot water is supplied from the internal cylinder at the storage temperature. The initial 55 litres will be at storage temperature. After this the water temperature will alter according to the flow rate [see 1.3 on page 5

of the installation guide].

When the demand ceases the cylinder will be heated to the desired storage temperature, then if required the central heating will resume.

1.3 OPERATING INSTRUCTIONS

1.3.1 Boiler ignition [fig. 24]

The first ignition of the boiler must be carried out by qualified technical personnel. Successively, if it is necessary to start up the boiler again, adhere strictly to the following instructions: open the gas isolation to allow the flow of the fuel.

Move the mains supply switch of the system to "ON".

A sequence of checks will be carried out and the display shows as in fig. 24, indicating the pressure of the system. Correct functioning is indicated by the presence of a blue luminous bar.

N.B.: The first press of the keys illuminates the display. It will remain illuminated for 30 seconds (default setting) from the last key press.

Winter

Press the key * of the controls (pos. 2) to activate the winter mode functioning (heating and D.H.W.). The display will be as shown.

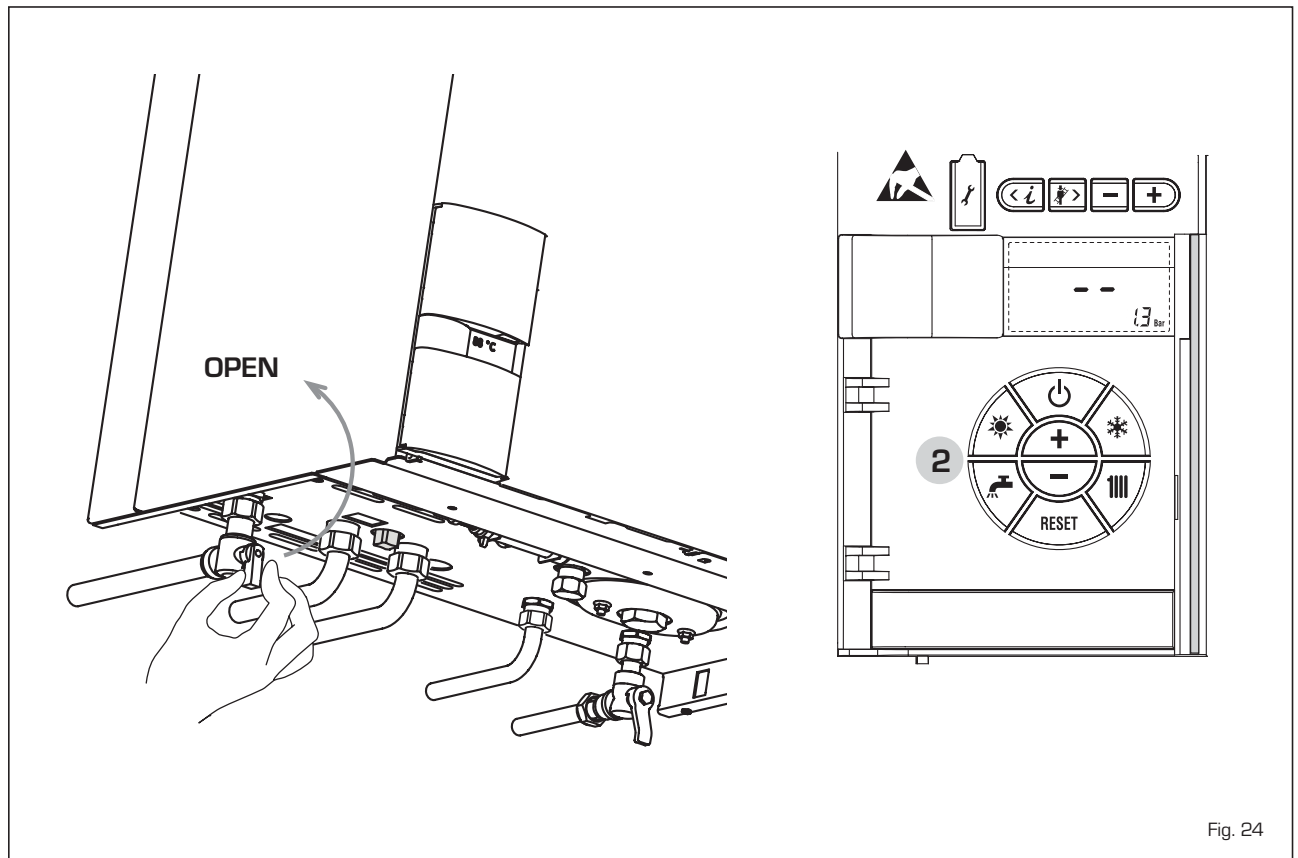
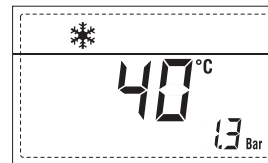
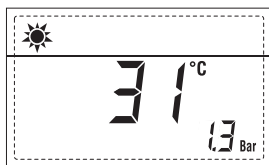

Fig. 24

Summer

Press the key ☀ of the controls (pos. 2) to activate the summer mode functioning (only the production D.H.W.). The display will be as shown :



1.3.2 Regulation C.H. temperature (fig. 25)

To set the temperature of the water for heating, press the key IIII of the controls (2).

The first time the key is pressed, the SET of heating circuit 1 is selected. The second time it is pressed, the SET if second zone fitted is selected. The display will be as shown in figure 25.

Change the values with the key + and -.

The standard display will return if the IIII is pressed again, or after 10 seconds if no key is pressed.

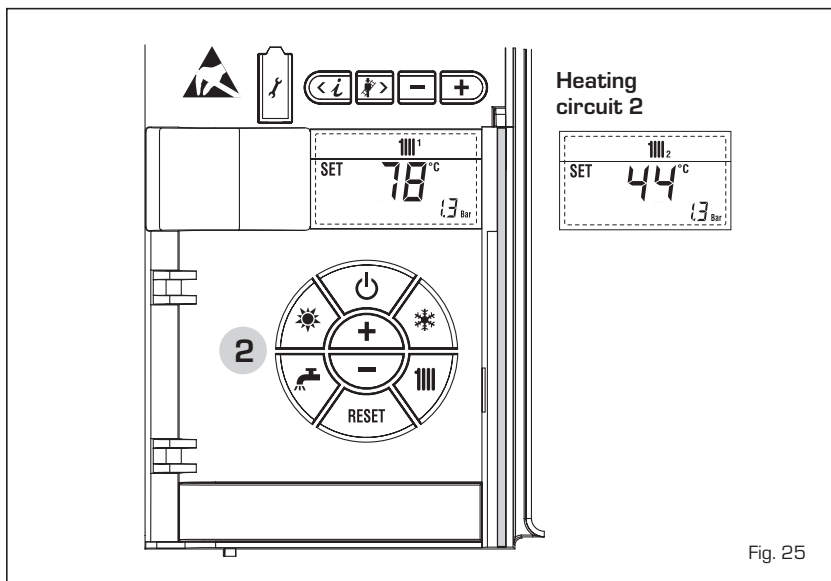

Fig. 25

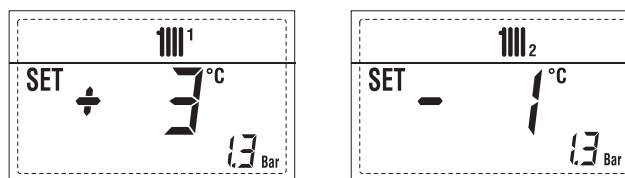

Fig. 25/a

Regulation of the external sensor

If an external sensor is installed, the value of the output temperature is automatically chosen by the system, which quickly adjusts the environmental temperature on the basis of the external temperature.

If you wish to change the value of the temperature, increasing or decreasing that calculated automatically by the electronic card, proceed as indicated in the preceding paragraph.

The level of various correction of a value of temperature proportional calculated. The display will be as shown in fig. 25/a.

1.3.3 Regulation D.H.W. temperature (fig. 26)

To set the desired temperature of the stored D.H.W., press the key 🔑 of the controls (pos. 2).

The display will be as shown in the figure 26.

Change the values with the key + and -.

The standard display by pressing the key 🔑 again, or after 10 seconds if no key is pressed.

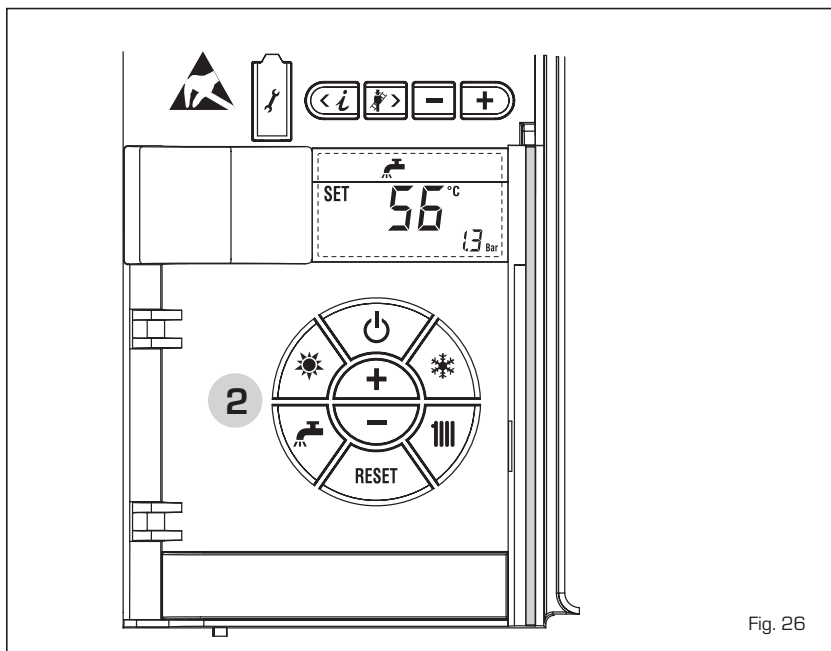

Fig. 26

1.3.4 To switch off the boiler (fig. 24)

In the case of a short absence, press the key ⏻ of the controls (pos. 2).

The display will be as shown in the fig. 24. In this way, leaving the electricity and the fuel supply connected, the boiler is protected from frost and from

the pump becoming jammed.

If the boiler is not used for a prolonged period, it is advisable to disconnect the electricity supply, by switching off the main switch of the system, and to close the gas first and, if low temperatures are expected, to completely empty the hydraulic circuits to avoid pipes being frost damaged.

1.4 ERRORS AND SOLUTIONS

When there is a functioning error, the display shows an alarm and the blue luminous bar becomes red.

Descriptions of the errors with the relative alarms and solutions are given below:

- **ALL 01** (fig. 27)
Seek help and advice from a qualified engineer.

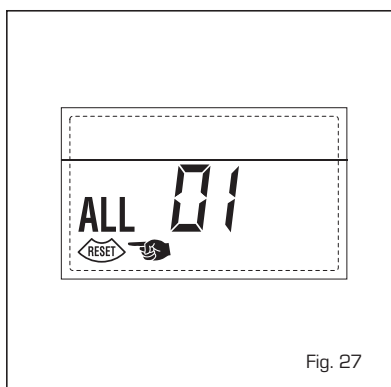

- **ALL 02** (fig. 27/a)
If the water pressure detected is lower than 0.5 bar, the boiler will stop and the display will show "ALL 02". To proceed increase the system pressure to between 1 and 1.5 bar.

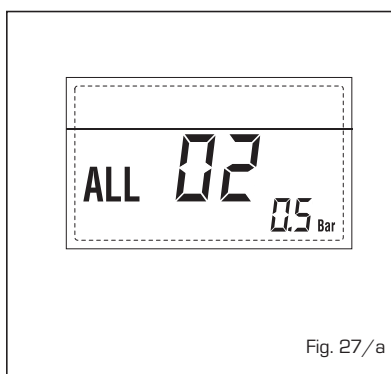

- **ALL 03**
The system pressure detected is more than 2.8 bar.
Ensure that the filling loop is turned off and the pipe detached. Lower the system pressure by draining from a radiator.
If the problem persists seek help from a qualified engineer.
- **ALL 05**
Seek help and advice from a qualified engineer.

qualified engineer.

- **ALL 06** (fig. 27/c)
Press the key  of the controls (2) to re-start the boiler.
If the error persists seek help and advice from a qualified engineer.

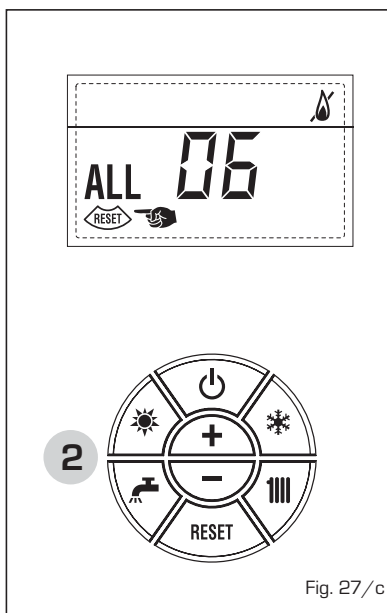

- **ALL 07** (fig. 27/d)
Press the key  of the controls (2) to re-start the boiler.
If the error persists seek help and advice from a qualified engineer.

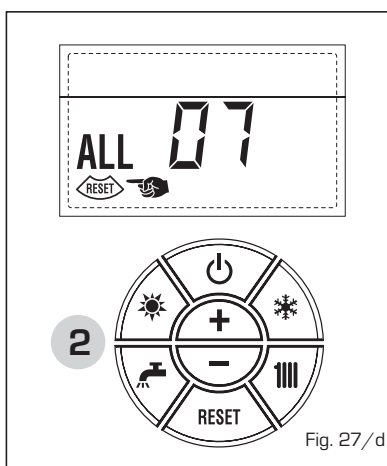

- **ALL 08**
Seek help and advice from a qualified engineer.
- **ALL 09**
If the boiler detects inadequate system water circulation. The boiler will stop and display AL 09. Ensure that at least one radiator is turned on and that all isolation valves are

open. If the problem persists it could be due to a blocked filter within the boiler, seek help from a qualified engineer.

- **ALL 10**
Seek help and advice from a qualified engineer.
- **ALL 13** (fig. 27/e)
Press the key  of the controls (2) to re-start the boiler.
If the error persists seek help and advice from a qualified engineer.

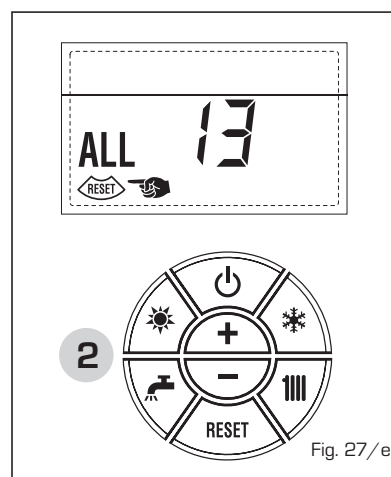

- **ALL 14**
Seek help and advice from a qualified engineer.
- **ALL 15**
Seek help and advice from a qualified engineer.
- From "ALL 20" to "ALL 29"
Request assistance from qualified technical personnel.

1.5 MINIMUM CLEARANCES

The following MINIMUM CLEARANCES must be available for servicing the appliance:

	For servicing
ABOVE THE APPLIANCE CASING	300 mm
AT THE R.H.S.	15 mm
AT THE L.H.S.	15 mm
BELOW THE APPLIANCE CASING	200 mm
IN FRONT OF THE APPLIANCE	500 mm

1.6 ROUTINE SERVICING

To ensure continued efficient operation of the appliance, it is recommended that it is checked and serviced as

necessary at regular intervals. This is also a condition of the boiler warranty. The frequency of servicing will depend upon the particular installation conditions and usage but at least once a year. It is the law that any service work must be carried out by a Gas Safe Registered Engineer.

**EXTINGUISH ALL NAKED LIGHTS.
CONTACT THE GAS EMERGENCY
SERVICE, PHONE NUMBER
0800111999.**

1.7 ELECTRICAL SUPPLY

THIS APPLIANCE MUST BE EARTHED. The mains supply must be fused at 3 amp.

1.8 VENTILATION

If the appliance is installed in a cabinet, the cabinet **MUST NOT** be used for storage purposes.

Any ventilation provided for the appliance during installation **MUST NOT** be blocked and a periodic check must be made to ensure that the vents are free from obstructions.

1.8.1 Cleaning

Use only a damp cloth and mild detergent to clean the appliance outer casing. **DO NOT** use abrasive cleaners.

1.9 SAFETY

It is essential that the instructions in this booklet are strictly followed for the safe and economical operation of this appliance.

The appliance functions as a fan assisted balanced flue unit. The flue terminal **MUST NOT BE OBSTRUCTED** under any circumstances.

If damaged, turn off the appliance and consult the installer, service engineer, or gas supplier.

If it is known or suspected that a fault exists on the appliance it **MUST NOT** be used until the fault has been rectified by a competent person.

WARNING:

IF A GAS LEAK IS SUSPECTED OR EXISTS, TURN OFF THE GAS SUPPLY TO THE APPLIANCE AT THE GAS SERVICE COCK.

DO NOT OPERATE ANY ELECTRICAL SWITCHES. DO NOT OPERATE ANY ELECTRICAL APPLIANCE.

**OPEN ALL WINDOWS AND DOORS.
DO NOT SMOKE.**

MECHANICAL TIME CLOCK - Code 8092228

Setting the time

The time of day can be set by grasping the outer edge of the black dial and turning it in a clockwise direction until the correct time is in line with the white pointer.

Setting the "switching time"

The "ON" periods are set by sliding the blue tappets, adjacent to the time periods required, to the outer edge of the dial.

The tappets that remain at the centre of the dial will be the "OFF" periods.

N.B.: The smallest switching time (ON or OFF) is 15 minutes.

- To select "Timed" mode move the selector switch in the middle of the clock face to the "⌚" position.
- To select "Constant" mode move the selector switch in the middle of the clock face to the "I" position.
- To select "OFF" mode move the selector switch in the middle of the clock face to the "O" position.

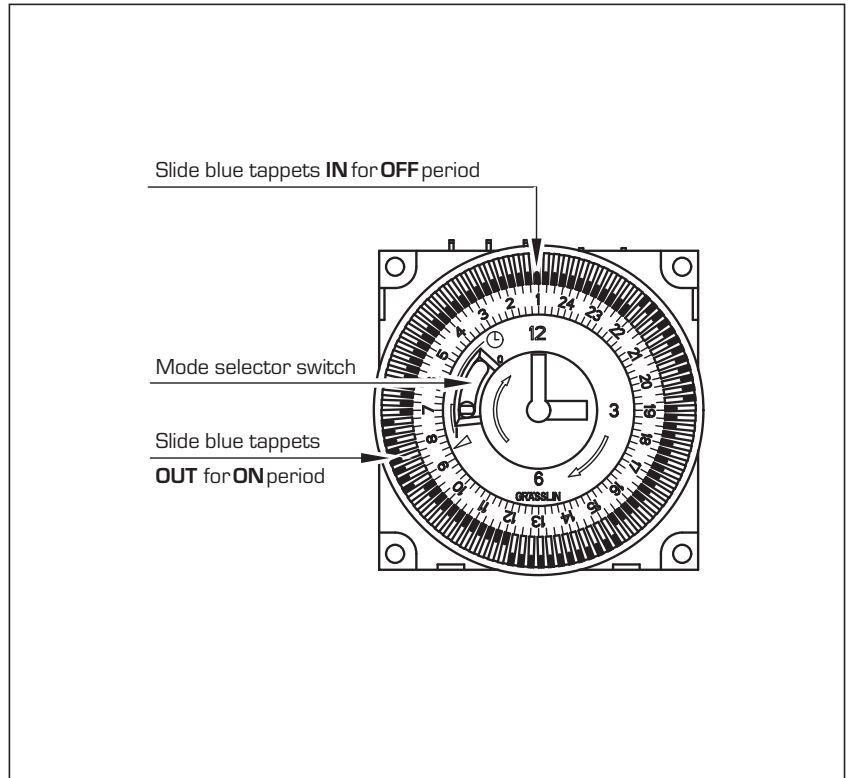

DIGITAL TIME CLOCK - Code 8092229

When the selector is in the "AUTO" position, boiler functioning is automatically controlled on the basis of the temperature levels and time periods set. The second selector must be in the "RUN" position to start. The programming procedure is described below:

- Setting the time

Set the selector to the "CLOCK" position. Press "h" to change the hour on the display, or "m" to change the minutes. To set the day, press the "1...7" button until the arrow is pointing to the correct day (1 = Monday... 7 = Sunday).

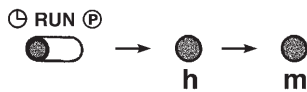

- Setting the program

The time clock has 8 on times and 8 off times. To make it easier to use, the time clock is supplied with 3 on times and 3 off times already set for each day of the week, as shown below:

Program	Time
1	06,00
2	09,00
3	12,00
4	14,00
5	18,00
6	22,00

NOTE: No program is set from 7 through 17.

To select programmes other than those already set, move the selector to position "P"; "0:001" will appear on the display, in which the first three digits indicate the hour and minutes, while the fourth digit identifies the program number. Odd-numbered programs identify requests for operation (day temperature), in which case the light bulb symbol will appear on the display, while even-numbered programs identify drops in temperature (night). Use the "1...7" key to select the day of the week (from 1 to 7) or days (1 ÷ 5, 6 - 7; 1 ÷ 6 or every day if the program is to be repeated every day of the week). Set the hour and minutes with the "h" and "m" buttons.

Press "P" to store the operation in memory and go on to the next program. Repeat the same procedure to set the remaining programs.

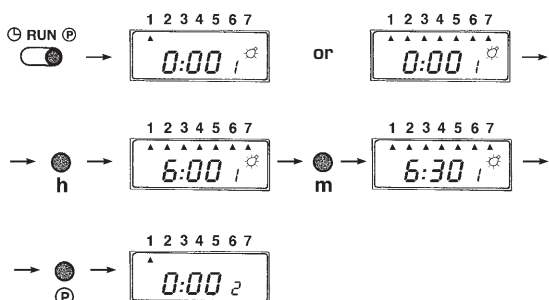

When finished programming, set the selector to "RUN" position.

- Deleting one or more programs

The on and off time must be deleted for each program to be deleted.

Set selector (2) to position "P". Select the desired program with button (3), then press button (4) to delete the day setting (the triangular symbols for the days should go away). If part of the program is deleted, when you set selector (2) back to the "RUN" position an error will appear in the clock display, referring to the program which is incorrect.

To delete all programs, put the selector in position "P" and press buttons (3) and (5) at the same time.

- Setting the SKIP function

The SKIP function deactivates programs for the next day and resumes regular programming 24 hours later.

This function is useful if you will be out all day and don't need heating.

To start this function, press button (7), which is active only when selector (2) is in "RUN" position.

Once you have selected the SKIP function, it will go into effect at 0:00 of the next day for 24 hours.

You cannot turn it off once it has started, so regular programming will not resume until 24 hours have passed.

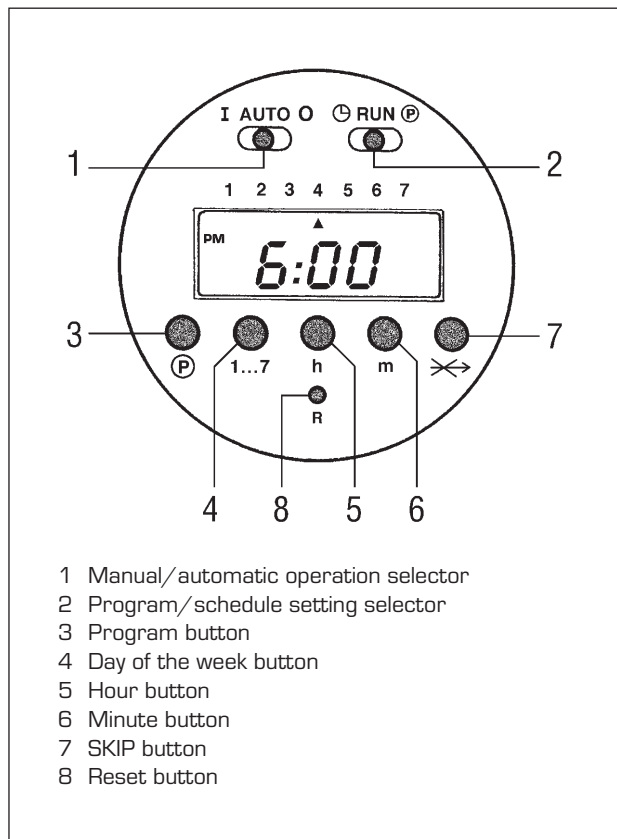

ANALOGIC RF TIME PROGRAMMER - Code 8092231

4. Commissioning (The Receiver and the Transmitter are pre-commissioned)

- a. Turn on electrical supply to boiler and turn boiler selector to 
- b. Press and hold black button on Receiver until the neon light has flashed twice.
- c. Release the button and the neon light will remain illuminated.
- d. Insert the batteries into the Transmitter - the Transmitter will immediately send signals.
- e. When a signal is received from the Transmitter, the Receiver neon will go out. The radio link between the Transmitter and Receiver is now established.

Note: When in operation and an 'ON' signal is received the Receiver neon will illuminate continuously. When an 'OFF' signal is received the neon will remain off, but will flash intermittently.

5. User Instructions - see Fig. 5

Note: Panel (A) slides back to reveal quick reference user instructions (B).

a. Set Time

Slide cover (D) off the Transmitter (C). Turn the outer dial clockwise to set the clock hands to the correct time. Ensure the time corresponds with the correct time on the 24hr dial as shown. e.g. 3.00pm = 15 not 3.

Note: Do not rotate anti-clockwise or damage may occur to the unit. Rotate the minute hand with your finger to set the exact time.

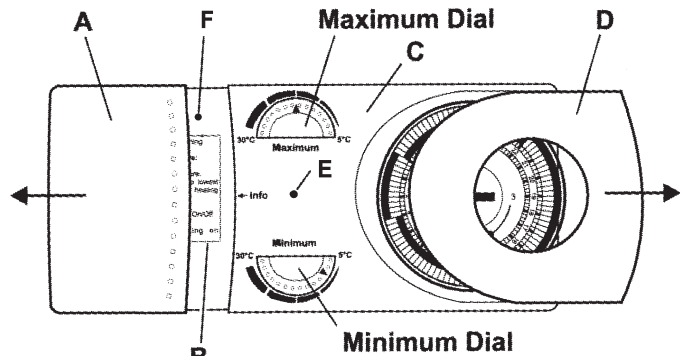

Fig. 5

b. Set Heating ON/OFF Periods

Select the ON times by pushing the tappets to the outside.

Select the OFF times by pushing the tappets to the inside.

Fig. 6 shows the clock set as follows:

- ON 3.00pm to 10.00pm (15-22)
- OFF 10.00pm to 5.00am (22-5)
- ON 5.00am to 8.00am (5-8)
- OFF 8.00am to 3.00pm (8-15)

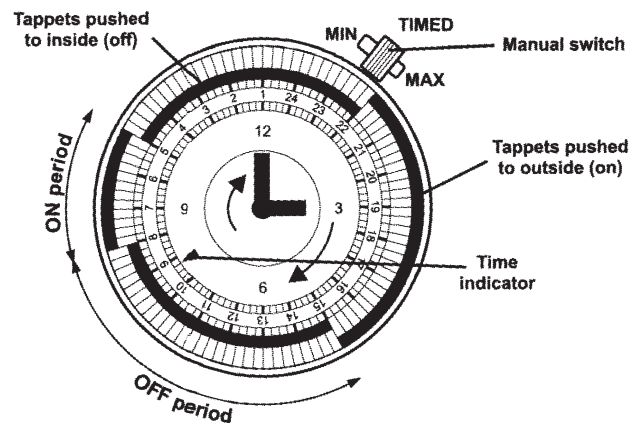

Fig. 6

c. Set Maximum/Minimum Room Temperatures

Maximum setting - Rotate the Maximum dial (see Fig. 5) to give the required room temperature upto 30°C when heating is on.

Minimum setting - Rotate the Minimum dial (see Fig. 5) to a lower temperature down to 5°C to ensure that when the heating is off a minimum room temperature is maintained.

d. Manual Switch - see Fig. 6

The clock has a manual heating ON/OFF switch which operates as follows:





TIMED position - Heating On/Off as set by tappets.

MAX position - Heating On continuously.

MIN position - Heating Off, but a minimum set room temperature is maintained.

DIGITAL RF TIME PROGRAMMER - Code 8092232











4. Commissioning (The Receiver and the Transmitter are pre-commissioned)

- Turn on electrical supply to boiler and turn boiler selector to 
- Press and hold black button on Receiver until the neon light has flashed twice.
- Release the button and the neon light will remain illuminated.
- Press and hold the top and bottom button on the Transmitter at the same time until Ed 01 is displayed. Then press 
- Then, Fu on (flashing) is displayed. Then press 
- The symbol  will flash on the Transmitter display approximately every 5 seconds. The transmitter is now in continuous radio operation.
- When a signal is received from the Transmitter, the Receiver neon will go out. The radio link between the Transmitter and Receiver is now established.
- Press the Selector button or  to return to normal operation.





Note: When in operation and an 'ON' signal is received the Receiver neon will illuminate continuously. When an 'OFF' signal is received the neon will flash intermittently.

5. User Instructions - see Fig. 5





a. Set Time

- Press the Menu button until flashing  is displayed
- Press the /  buttons to set current HR, then press 
- Press the /  buttons to set current MIN, then press 
- Press the /  buttons to set current DAY (1 = Monday, 7 = Sunday), then press 

b. Set Maximum Room Temperature

- Press the Menu button until flashing  is displayed
- Press the /  buttons to select the required maximum room temperature, then press 



c. Set Minimum Room Temperature



- Press the Menu button until flashing  is displayed
- Press the /  buttons to select the required minimum room temperature, then press 

d. Set Heating Programme

- Press the Menu button until a flashing P1, P2, P3, P4 or Pd is displayed
- P1 - ON between 7am and 11pm
- P2 - ON between 6am and 9am then 5pm and 10pm
- P3 - ON for 24hrs
- P4 - OFF for 24hrs except when the minimum room temperature is reached, when it will come on
- Pd - Daily programmes can be set individually

Note: Programmes P1 to P4 cannot be changed.

If selecting a programme between P1 and P4 press the /  buttons until the programme required is displayed, then press  for each day.

To set a Pd programme, press the  button for **OFF** periods and press the  button for **ON** periods, then press . Repeat for each day.

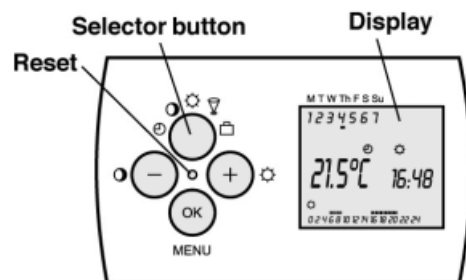

Fig. 5

INSTRUCTIONS FOR CR 73 - Code 8092226



Help ensure optimal heating!

Take full advantage of the room unit's capabilities!

Operating Instructions

You want to switch on the heating

1. Turn on the main switch.
2. Set the correct time of day, date and year.
3. Select automatic mode.

You want to set the time of day or the date

Select the line	Display (line / text)	Make the setting	Value (example)
Prog	1 / Time		13:45
Prog	2 / Date		20. Jan
Prog	3 / Year		2001

You want to change the operating mode of heating

After opening the cover, you can select the heating circuit's operating mode by pressing the button at top right.

Automatic mode

In automatic mode, the room temperature is controlled according to the selected heating periods.

Tip: select the heating periods that suit your daily needs; this will result in considerable energy savings.

Continuous operation

Continuous operation maintains the room temperature at the level adjusted with the setting knob.

Standby mode

In standby mode, the heating is switched off, but remains protected against frost (frost protection temperature).

You want to change d.h.w. heating

D.h.w. heating can be switched on or off by pressing the button at top left.

You want to leave the rooms for a longer period of time

If you do not use the rooms for a longer period of time, you can reduce the room temperature by pressing the occupancy button, thus saving heating energy. If the rooms are used again, press the occupancy button again so that the room temperature will return to the normal level. The display shows the selection made:

- Nominal room temperature
- Reduced room temperature

The current selection acts:

in continuous operation always

in automatic mode only until the next switching point according to the heating program is reached

Your rooms are too warm or too cold

1. Check the current operating state on the display.
2. In the case of nominal room temperature: lower or raise the room temperature with the setting knob.
3. In the case of reduced room temperature:

Select the line	Display (line / text)	Make the setting
Prog	5 / Room reduced	

Tip: each time you make a room temperature readjustment, wait at least 2 hours, allowing the room temperature to adapt.

You want to change the heating periods

1. The heating program can be changed with setting lines 10 to 16. To set a time switch program, always preselect the 7-day block or an individual day. Then, set the switching times of the heating periods (maximum 3) for the selected weekday (start / end).

Select the line	Display (line / text)	Select 7-day block or individual day	Value (example)
Prog	10 / Day		Week Mo/Tu...

2. Set the switching points for the preselected weekdays:

Select the line	Display (line / text)	Set the times of the first heating period	Value (example)
Prog	11 / 1. Start		06:00
Prog	12 / 1. End		11:00

3. Proceed in the same way to make the settings for the other 2 heating periods (setting lines 13 to 16).

Is there a second heating circuit? That heating program can be changed with setting lines 20 to 26.

Tip: you can retrieve the standard time program on line 45 by pressing simultaneously the + and - buttons for 3 seconds.

The d.h.w. is too hot or too cold

Select the line	Display (line / text)	Readjust the temperature	Value (example)
Prog	7 / D.h.w. nominal		60 °C

You want to enter a holiday period

You can enter a holiday period. At the start of the holiday period, the room unit will switch to the reduced mode. On completion of the holiday period, the entry will be cleared.

Select the line	Display (line / text)	Make the setting	Value (example)
Prog	40 / Holidays start		28. Aug
Prog	41 / Holidays end		15. Sep

You want the display in another language

Information can be displayed in different languages.

Select the line	Display (line / text)	Select the language
Prog	47 / Language	
Prog	48 °C/°F	

Meaning of the following information

By pressing the Info button, you can query a number of values. Each time the button is pressed, a new value is displayed (e.g. the actual room temperature).

The display also contains symbols. They indicate the current operating state. If one of them appears, the relevant state is ACTIVE.

- Nominal room temperature (setting knob)
- Reduced room temperature
- Frost protection temperature
- Flame present
- Flashes when there is a fault or maintenance message

Your heating system does not operate as required

Check the fault or maintenance message by pressing the Info button once. The display will show an error code: contact your heating engineer and give him the error code.

Do you know these energy saving tips?

- During the day, do not allow room temperatures to exceed 21 °C
- Air rooms for short periods of time only, with the windows fully open
- In unoccupied rooms, set the thermostatic radiator valves to their frost protection position
- Make certain the radiators are not covered by curtains, furniture, etc.

Note: for more information, please refer to the detailed documentation of your heating system.



Sime Ltd

1a Blue Ridge Park
Thunderhead Ridge
Glasshoughton, Castleford, WF10 4UA

Phone: 0845 9011114

Fax: 0845 9011115

www.sime.co.uk

Email: enquiries@sime.co.uk