

STREBEL

S-CB⁺ Boiler Range

Models +400 & +550

Floor Standing High Efficiency Condensing Boiler

Installation, Operating & Maintenance Manual



Please read and understand before commencing installation and leave the manual with the customer for future reference.

TABLE OF CONTENTS

INTRODUCTION.....	6
1 SAFETY GUIDELINES.....	6
2 TECHNICAL DATA S-CB+400 AND S-CB+550.....	7
2.1 INTRODUCTION.....	7
2.2 TECHNICAL SPECIFICATIONS DATASHEET.....	8
2.3 ERP SPECIFICATION DATASHEET.....	10
2.4 SAFETY MEASURES FOR PREVENTING INTERNAL FLUE GAS RECIRCULATION.....	11
2.5 BENEFITS OF THE S-CB+ 400 & 550 BOILER.....	11
2.6 DESCRIPTION OF THE MOST IMPORTANT BOILER PARTS.....	12
3 TECHNICAL DIMENSIONS OF THE S-CB+400 / S-CB+550.....	13
4 ACCESSORIES AND UNPACKING OF THE BOILER.....	14
4.1 ACCESSORIES.....	14
4.2 UNPACKING.....	14
5 INSTALLATION OF THE S-CB+ 400 & 550.....	15
5.1 GENERAL NOTES.....	15
5.2 BOILER ROOM.....	15
5.2.1 General.....	15
5.2.2 Boiler room.....	15
5.2.3 Ventilation.....	16
5.3 REMOVING THE TOP, FRONT AND SIDE PANELS.....	16
5.4 MOUNTING THE BOILER.....	17
6 CONNECTIONS WATER SIDE.....	17
6.1 BOILER CONNECTIONS.....	17
6.2 CONDENSATE DRAIN CONNECTION.....	18
6.3 FLOW AND RETURN CONNECTIONS.....	18
6.4 THE EXPANSION VESSEL.....	18
6.5 PRESSURE RELIEF VALVE.....	19
6.6 BYPASS.....	19
6.7 PUMP FUNCTIONALITY.....	19
6.8 FROST PROTECTION.....	19
6.9 INSTALLING A STRAINER AND/OR DIRT SEPARATOR.....	20
6.10 WATER QUALITY.....	20
6.11 PLASTIC PIPING IN THE HEATING SYSTEM.....	21
6.12 AUTOMATIC AIR VENT.....	21
6.13 AUTOMATIC WATER FILLING SYSTEMS.....	21
6.14 WATER PRESSURE.....	21
6.15 CHEMICAL WATER TREATMENT.....	22
6.16 UNDER FLOOR HEATING.....	22
6.17 FLUSH THE SYSTEM WITH FRESH WATER.....	22
6.18 INSTALLATION EXAMPLES.....	22
6.18.1 Installation containing one S-cb+ 400 / 550 CH boiler.....	22
6.18.2 Installation containing two S-cb+ 400/550 CH boilers using NON-RETURN valves.....	23
7 HYDRAULIC GRAPHS.....	24
8 FLUE GAS AND AIR SUPPLY SYSTEM.....	25
8.1 GENERAL.....	25
8.2 FLUE GAS SYSTEM.....	25
8.3 BOILER CATEGORIES - TYPES OF FLUE GAS SYSTEMS.....	26
8.4 C63 CERTIFIED.....	27
8.5 FLUE TERMINAL.....	28
8.5.1 Vertical Flue Terminal Positioning.....	28
8.5.2 Common Flue / Ducts.....	28
8.6 AIR SUPPLY.....	28
8.6.1 Air quality.....	28
8.6.2 Air supply through humid areas.....	28
8.7 PIPE HEIGHTS AND MUTUAL DISTANCES ON A FLAT ROOF.....	29

8.8	S-CB+ 400 & 550 AIR INLET / FLUE GAS OUTLET CALCULATION EXAMPLES.....	30
8.8.1	Flue gas and air supply resistance table - concentric parts	30
8.8.2	Twin pipe flue gas and air supply resistance table:.....	31
8.8.3	Example A: Twin pipe system.....	32
8.8.4	Example B: Single pipe system for flue gas outlet only	33
8.8.5	Example C: Twin pipe system with wall mounted air duct.	34
8.8.6	Example D1: Twin pipe system with concentric roof terminal.	35
8.8.7	Example D2: Twin pipe system with concentric roof terminal.	36
8.9	SEPARATE AIR SUPPLY AND FLUE TERMINAL FOR A PITCHED ROOF	37
8.10	SEPARATE AIR SUPPLY AND FLUE TERMINAL FOR A FLAT ROOF	37
9	ELECTRICAL INSTALLATION.....	38
9.1	GENERAL	38
9.2	CONNECTIONS.....	39
9.3	CASCADED CONNECTION INCLUDING SHIELDING.....	39
9.4	CONNECTING THE POWER SUPPLY AND BOILER PUMP P1, 230V/1~ OR 400V/3~	40
9.5	FUSES.....	41
9.6	LIST FOR CONNECTIONS	41
9.7	SENSORS	43
9.8	ELECTRICAL CIRCUIT DIAGRAM TOP BURNER (PCB A, LEFT)	44
9.9	ELECTRICAL CIRCUIT DIAGRAM BOTTOM BURNER (PCB B, RIGHT)	46
10	USER INTERFACE.....	48
10.1	CONTROL PANEL / DISPLAY UNIT	48
10.2	MENU STRUCTURE	49
10.3	DISPLAY DURING OPERATION.....	51
10.4	MONITOR SCREENS.....	52
10.5	SERVICE FUNCTION.....	54
10.6	SCHORNSTEIFEGER FUNCTION	55
10.7	PROGRAMMING IN STANDBY MODE.....	56
10.8	SETTING THE TIME & DATE.....	56
10.9	SET POINTS.....	57
10.10	SETTING THE TIMER PROGRAMS	58
10.11	SETTING THE OUTDOOR SPECIFICATIONS	61
10.11.1	Parameters for setting the outdoor graph	61
10.11.2	Outdoor graph - main settings.....	62
10.11.3	Outdoor graph - additional settings.....	63
10.11.4	Display.....	64
10.12	CHECKING THE OPERATING HISTORY.....	65
10.13	CHECKING THE FAULT HISTORY.....	66
10.14	SETTING THE MAINTENANCE SPECIFICATIONS	67
10.15	SETTING THE USER LOCK	70
10.16	SETTING THE PARAMETERS AT THE CONTROL PANEL.....	71
10.17	FAULT CODES DISPLAY.....	78
10.17.1	Lock-out codes.....	78
10.17.2	Blocking codes.....	80
10.17.3	Important message	81
11	CONTROLLING OPTIONS AND SETTINGS	82
11.1	GENERAL	82
11.1.1	Extra boiler control	82
11.1.2	Max cooling time	82
11.1.3	temperature display on/off.....	82
11.1.4	Water pressure.....	82
11.1.5	Gas type selection.....	82
11.1.6	Soft start option.....	83
11.1.7	Pump mode (EC technology).....	83

11.2	HEATING	84
11.2.1	Controlling behaviour settings.....	84
11.2.2	Room thermostat on/off.....	84
11.2.3	Room thermostat OPENTHERM.....	85
11.2.4	Outside temperature related flow control.....	85
11.2.5	0-10 VDC remote flow temperature set point.....	85
11.2.6	0-10 VDC remote burner input control.....	86
11.2.7	timer contact function.....	86
11.3	INDIRECT HOT WATER / CALORIFIER.....	87
11.3.1	pump and 3-way valve control.....	87
11.3.2	tank thermostat.....	87
11.3.3	tank sensor.....	87
11.3.4	Low/high flow temperature to tank coil.....	88
11.3.5	Heating and hot water switching time.....	89
11.3.6	Heating and hot water switching time at a sudden temperature drop.....	89
11.3.7	anti-Legionnaires' disease (pasteurisation) function.....	90
11.4	CASCADE CONTROL.....	91
11.4.1	Parameter settings for cascaded boilers.....	91
11.4.2	Monitor screens.....	93
11.4.3	Output control and burner sequence.....	93
12	COMMISSIONING THE BOILER	94
12.1	FIRST: FLUSHING THE BOILER WITH WATER.....	94
12.2	SECOND: FILLING & VENTING THE BOILER AND THE SYSTEM.....	94
12.3	THIRD: CHECK THE WATER FLOW.....	94
13	STARTING THE BOILER.....	96
13.1	GENERAL.....	96
13.2	FIRING FOR THE FIRST TIME.....	97
14	ADJUSTING AND SETTING THE BURNERS.....	98
14.1	INTRODUCTION.....	98
14.1.1	Adjustment tables.....	98
14.1.2	Adjustment values.....	98
14.1.3	Gas valve setting screws: drawing.....	100
14.1.4	How to remove and mount the flue plug:.....	101
14.1.5	Adjustment actions: general scheme.....	102
14.1.6	Note: CO ₂ measuring position.....	103
14.2	ADJUSTING IN CASE OF A NEW BOILER, OR AFTER MAINTENANCE (CASE A).....	103
14.2.1	General remark.....	103
14.2.2	Checking and adjusting the bottom burner.....	104
14.2.3	Checking both burners.....	104
14.3	ADJUSTING AFTER GAS VALVE REPLACEMENT OR IN CASE OF GAS CONVERSION (CASE B).....	105
14.3.1	General remarks.....	105
14.3.2	Case B adjustments.....	105
14.3.3	Setting parameter P4BD gas type (display D8).....	106
15	PUTTING THE BOILER OUT OF OPERATION	107
16	FAULT CODES, BLOCKING CODES	108
16.1	FAULT CODES.....	108
16.2	BLOCKING CODES.....	115
16.3	MAINTENANCE ATTENTION MESSAGE.....	119
17	MAINTENANCE.....	120
17.1	GENERAL.....	120
17.2	INSPECTION & MAINTENANCE.....	120
18	USER INSTRUCTIONS	123
19	EXAMPLES OF INSTALLATIONS	124

INTRODUCTION

This manual is written for:

- The installer.
- System design engineer.
- The service engineer.
- The user.

The following symbol is used in this manual:



Warning: Important information concerning the safety of persons and/or the appliance.

Strebel Ltd is not accountable for any damage caused by incorrect following the mounting instructions. For service and repair purposes use only original Strebel spare parts.

All documentation produced by the manufacturer is subject to copyright law.

1 SAFETY GUIDELINES

Read all these instructions before commencing installation.

Keep this user manual near the boiler for quick reference.

The appliance should be installed by a skilled installer according to all applicable standards and regulations. Failure to comply with these regulations could deem the warranty invalid.

Without written approval of the manufacturer the internals of the boiler may not be changed. When these changes are executed without approval, the boiler certification is invalid.

Commissioning, maintenance and repair must be done by a skilled installer/engineer, according to all applicable standards and regulations.



What to do if you smell gas:

- Do NOT use any electrical equipment.
- Do NOT press any switches.
- Close the gas supply.
- Ventilate the room (open the windows and/or outside boiler room doors).
- Warn the installer immediately.



The manufacturer / supplier is not liable for any damage caused by inaccurately following of these mounting instructions. Only original parts may be used when carrying out any repair or service works.



This appliance is not intended for use by persons (including children) with reduced physical, sensory or mental capabilities, or lack of experience and knowledge, unless they have been given supervision or instruction concerning use of the appliance by a person responsible for their safety. Children should be supervised to ensure that they do not play with the appliance.

2 TECHNICAL DATA S-CB+400 AND S-CB+550

2.1 Introduction

The S-CB+ 400 & 550 heating boilers are central heating boilers with a maximum high efficiency. Such performance can also be reached by using a special heat exchanger made of stainless steel. The heat exchanger helps to cool down the flue gases below their condensation point; through this condensing of the flue gases extra heat is released. This has an immediate positive effect on the efficiency, exceeding the 100%.

The S-CB+ boiler is standard set for Natural gas G20

Gases used must comply with the European standard EN 437.

Fuel used should have sulphur rates within the European standard, a maximum annual peak over a short period of time of 150 mg/m³ and an annual average of 30 mg/m³.

Boiler control includes:

- Boiler pump control.
- Cascade control for up to six boilers.
- Remote signals from each burner:
 - Lock-out indication.
 - Heat demand indication.
 - Burner burning indication.
- Weather compensation control.
- Calorifier control.

Connections for:

- 0-10 VDC remote flow temperature (set point) control.
- 0-10 VDC remote burner input control.
- Outside temperature sensor.
- External calorifier pump or diverter valve.

Flue gas

Because the flue gases can have a low temperature, the boiler needs to have a high efficiency approved stainless steel flue gas system. Also, plastics of the right temperature class are allowed. For details, see applicable section.



Aluminium flue gas systems are never allowed to be connected to S-CB+ boilers.

Cascade control

When using the integrated cascade control, a maximum of six boilers (meaning twelve burners) can be controlled in a cascade configuration. When using dedicated control, this number can be increased at will.

0-10 VDC connection available

The boiler flow temperature or burner input can be controlled by an external 0-10 VDC signal. If several boilers are in cascade, using the integrated cascade control, the signal should be directed to the master boiler only. When using alternative control systems, all boilers in cascade systems may be controlled using these 0-10 VDC signals. A signal of 1,48 Volt will switch on the boiler(s), less than 1,4 Volt will switch off the boiler(s).

Time program

For both central heating and hot water function of the boiler, time programs with three programmable periods per day are available. These time programs can be set and activated directly at the boiler control panel.

2.2 Technical specifications datasheet

GENERAL			
Product Identification Number		CE 0063 BS3806	
Dimensions (h x w x d)	cm	161,7 x 73,6 x 122,5	
Classification		II2H3P	
Gas Appliance Type		B23, B23P; C13, C33, C43, C53, C63, C83	
Type boiler		S-CB⁺ 400	S-CB⁺ 550
CH boiler water content	litres	30	43
Weight (empty)	kg	400	450
Connections flow/return	inches	R 2 ½"	
Gas connection	inches	R 2"	
Flue gas / air supply connection ¹	mm	180-180	

HEATING		Values min-max:	
Nominal input (Net)	kW	50,0 – 400	68,0 – 550
Nominal input (gross) (G20, G25.3)	kW	55,4 – 444	75,5 – 611
Nominal input (gross) (G31)	kW	54,3 – 435	73,9 – 598
Nominal input (gross) (G30/G31)	kW	54,2 – 434	73,7 – 596
Nom. output 80/60°C	kW	48,3 – 386	66,1 – 535
Nom. output 50/30°C	kW	52,2 – 418	71,2 – 576
Nom. output 37/30°C	kW	54,1 – 433	73,7 – 597
Efficiency 40/30°C DIN4702-8	%	Up to 109,5	

GAS CONSUMPTION ² Gases according to EN437			Values min-max:	
Natural gas G25.3	m ³ _{st} /h		6,0 – 48,1	8,2 – 66,2
Natural gas G20	m ³ _{st} /h		5,3 – 42,3	7,2 – 58,2
Propane gas G31 ¹	m ³ _{st} /h		2,1 – 16,4	2,8 – 22,5
Butane/Propane (B/P) G30/G31 ¹	m ³ _{st} /h		1,6 – 12,4	2,1 – 17,1
Gas supply pressure nominal ³	G25.3	mbar	25	
	G20	mbar	20	
	G31 ²	mbar	30/37	
	G30/G31 ²	mbar	50	

NOTES			
¹ All boilers are supplied as twin pipe model.			
² Using propane, butane and B/P, maximum fan speed needs to be reduced (parameter P4BD)			
³ Below a table is given in which the min. and max. gas supply pressures are listed according to EN437:			
	p nominal [mbar]	p min [mbar]	p max [mbar]
G25.3	25	20	30
G20	20	17	25
G31	30	25	35
	37	25	45
G30/G31	50	43	57

Type boiler		S-CB+ 400	S-CB+ 550
EMISSION [EN437]		Nominal value at min. max. load	
CO ₂ flue gas G25.3, G20 min-max	%	9,0- 9,0	
CO ₂ flue gas G31, G30, B/P min-max	%	10,0-10,5	
NO _x class [EN483/ EN15420]	-	6	
Flue gas temperature at atmospheric temperature of 20°C	°C	90	
Mass flow flue gas [min-max] Q _{fluegas} condensing	g/s	24,1 - 207,8	33,1 - 285,7
Available pressure for the flue system ⁴	Pa	200	
Available pressure for the flue system with specified Concentric Roof Terminal ⁴	Pa	250	

INSTALLATION				
Hydraulic resistance of the boiler	ΔT = 20 K	mWK	4,0	4,1
	ΔT = 25 K	mWK	2,6	2,8
Water pressure boiler min-max.		bar	1,0 – 4,0 ⁵	
Maximum flow temperature		°C	85	

ELECTRICAL				
Power supply / frequency		V / Hz	230 (400 ⁶) / 50	
Maximum power consumption (exclusive pump)		W	960	
Max. current P1 pump relay (I nom)		A	9	
Protection class			IPX0B	

NOTES				
<p>⁴ Maximum combined resistance of flue gas and air supply piping at high fire.</p> <p>⁵ With the standard built-in pressure sensor replaced by a pressure switch, pressure may go up to 6.0 bar. Parameter P4AD needs to be changed.</p>		<p>⁶ 230 Vac is necessary for the boiler to function. If a 400 Vac boiler pump is applied, 400 Vac must be connected to the appliance so the power supply for the pump can be delivered by the system. (An optional safety switch for the pump motor must be added externally).</p>		

2.3 ERP specification datasheet.

Technical parameters according the European ERP (Energy Related Products) legislation:

Type Boiler:		S-CB+ 400	S-CB+ 550
Condensing boiler:		Yes	Yes
Low temperature boiler:		Yes	Yes
B11 boiler:		No	No
Cogeneration space heater:		No	No
Combination heater:		No	No
	Unit:	Value	Value
Rated heat output	kW	386	535
P-rated (P4) at 60-80°C	kW	386	535
Heat output (p1) 30% at 30-37°C	kW	129,9	179,1
Seasonal space heating energy efficiency (ηs).	%	92,54%	92,89%
energy efficiency (η4) at 60-80°C	%	86,90%	87,60%
energy efficiency (η1) at 30-37°C	%	97,50%	97,70%
Auxiliary electricity consumption			
At full load (elmax).	kW	0,752	0,829
At part load (elmin)	kW	0,12	0,12
In standby mode (Psb)	kW	0,015	0,016
Other			
Standby heat loss (Pstby)	kW	0,227	0,366
Ignition burner power consumption	kW	0,000	0,000
Emissions (Nox) of nitrogen oxides (EN15502-1:2012+A1:2015)	mg/kWh	44	41
Sound power level, indoors (EN 15036-1:2006)	dB	74	78

2.4 Safety measures for preventing internal flue gas recirculation

The heat exchanger of the S-CB+ 400 & 550 boiler contains two burners. The air supply channels of both burners are internally connected to each other, so the installer only needs to connect one air supply duct to the boiler. The controller allows the situation in which only one burner is burning, while the other one is off. When in this situation the flue gas canal resistance is (too) high, flue gases may go into the burner room of the burner that's off, instead of into the flue gas canal. These flue gases will flow into that burner room, pass its fan, and eventually enter the air supply to the other fan and back to the burning burner, influencing combustion of that burner negatively. The phenomenon is called recirculation.

Three safety features have been installed in the boiler to prevent this recirculation from happening.

1. **Non-return valve.** Behind both fans a non-return valve is installed. Both burners communicate with each other checking the non-return valve to be closed on the burner that is off so the other burner can burn. The non-return valve is equipped with a proximity switch which is signalling on the burner controller whether the valve is closed or opened. The communication between these burner controllers is checked every 20 seconds and when this fails the other burner(s) will be switched off. In normal operation of the boiler the fan of the burner that is not burning will be switched off because recirculation is prevented by the non-return valve and checked by the burner controller.
2. **Fan counter pressure.** If the electronic safety features are functioning well, a non-return valve fitted behind the fan will prevent recirculation (see 1). The position of this non-return valve is monitored continuously by the electronics. If the non-return valve is not closed the electronics will activate the fan to run at a speed relative to that of the fan of the other burner so enough pressure is created to prevent recirculation.
 - So, if the non-return valve is not functioning its function is taken over by the fan. In this case the unit will still be able to burn for 100% of its total capacity when both burners are used.
 - When the fan is not functional (of the burner that is not burning), this fan is not able to run and build up any pressure to prevent recirculation. The burner controller that controls that burner/fan then checks if the **non-return valve** is closed. If closed the burner controller communicates to the other burner controller(s) that it is able to burn. The unit has then only 50% of its total capacity because only one burner is available.
 - If both non-return valve and fan fail the complete unit will go into a lock out, if cascaded the other units will be blocked because this unit is in a lock out.
3. **Flue gas monitoring.** The tendency to re-circulate also depends of the flue gas resistance. Within normal operational specifications the boiler will not re-circulate. If the flue gas resistance (by blocking the canal) rises too high, a **pressure switch** will put the whole boiler into lockout.

2.5 Benefits of the S-CB+ 400 & 550 Boiler

The special features of this boiler range are:

- a. The weight is low:
Maximum 450 kg (empty) and filled with water 493 kg.
- b. Small dimensions: due to the width of 750 mm, the boiler can access premises using a standard door to bring it to the place, where it will be installed. It is easy to put the boiler on its exact position, by using the two wheels at the back.
- c. The small diameter of the air supply and flue gas discharge tube.
- d. The boiler consists of one heat exchanger with two burners that are controlled by the internal cascade management system.
- e. Extremely low noise production.
- f. Very small water content.
- g. Reliable through use of twin burner and smart electronics.

2.6 Description of the most important boiler parts

1. Fan

The fan is a compact unit: the motor and fan housing are an integral part and can be replaced as a complete unit. The fan varies in speed due to the boiler control, which ensures that the modulation of the boiler is attained.

2. Gas train

The boiler has two equal gas control valves (one for each burner).

Both gas control valves have two main gas valves internally that are opened simultaneously. When there is a heat demand, modulation takes place under the influence of the fan speed variation. The correct amount of gas is sucked in, by creating an under pressure through the fan, from the gas control valve.

3. Mixer

There is a mixer on the suction side of the fan(s) in which the gas and air are mixed together until a uniform gas/air quantity is obtained. This is pushed into the burner.

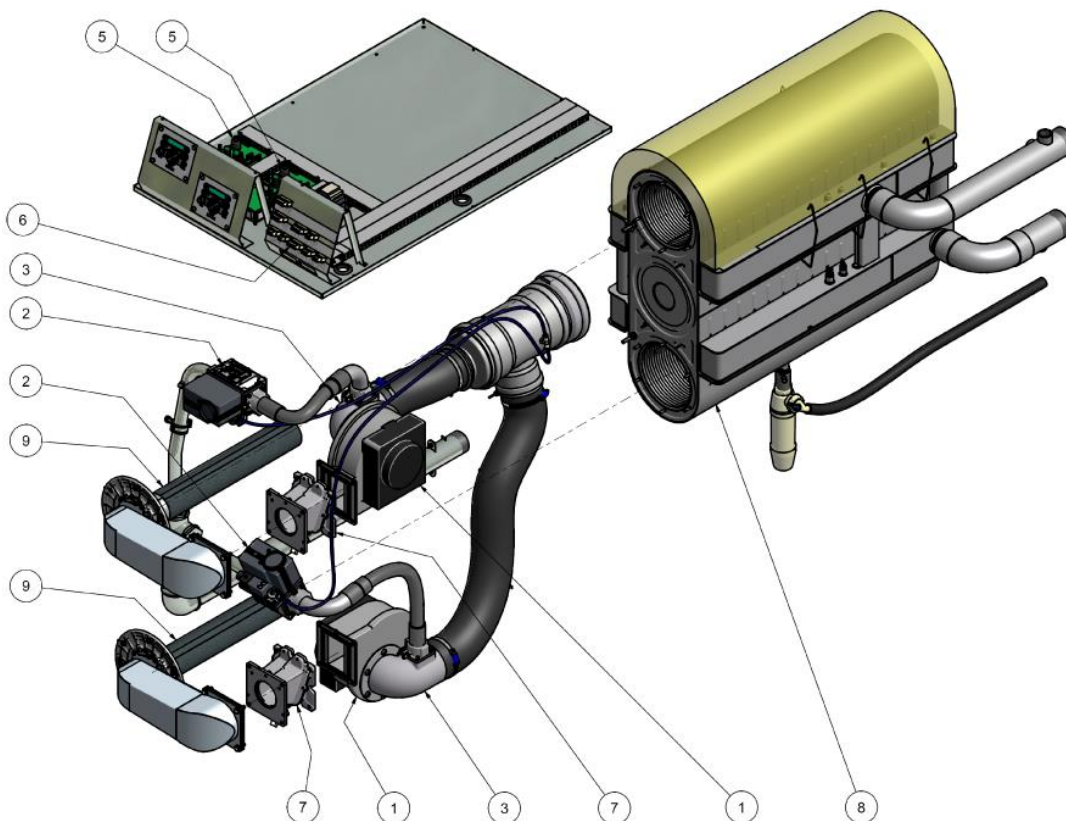

4. Boiler pump (not in drawing on this page)

The separately supplied boiler pump must be connected to the return of the boiler. The head of this pump must be sufficient to overcome the boiler resistance and the external system resistance for a connection to a low loss header.

5. Burner control

The boiler has two equal burner controls: one for each burner unit. One of the burner controls has a built-in cascade manager for the overall control of the boiler.

6. Electrical connections

All electrical components can be connected at the rear/top of the boiler. A relay has been installed to give power to the boiler pump.

7. Non-return valve

A non-return valve fitted behind the fan will prevent recirculation of flue gases from one burner to the other burner (when this burner is not operating).

8. Heat exchanger

The heat exchanger consists of spirals of stainless steel smooth tube. Through the openings between the spirals the flue gases are pushed, establishing an optimal heat transfer.

The ends of these spirals are welded with stainless steel nozzles that start at the return connection of the boiler and end in the supply connection of the boiler.

9. Burner

Both parts of the heat exchanger contain their own burner that consists of a perforated cylinder from stainless steel with an extra porous layer for protection against high temperatures. This porous layer is a weaving layer; the wires are made of an alloy with high temperature resistance.

3 TECHNICAL DIMENSIONS OF THE S-CB⁺400 / S-CB⁺550

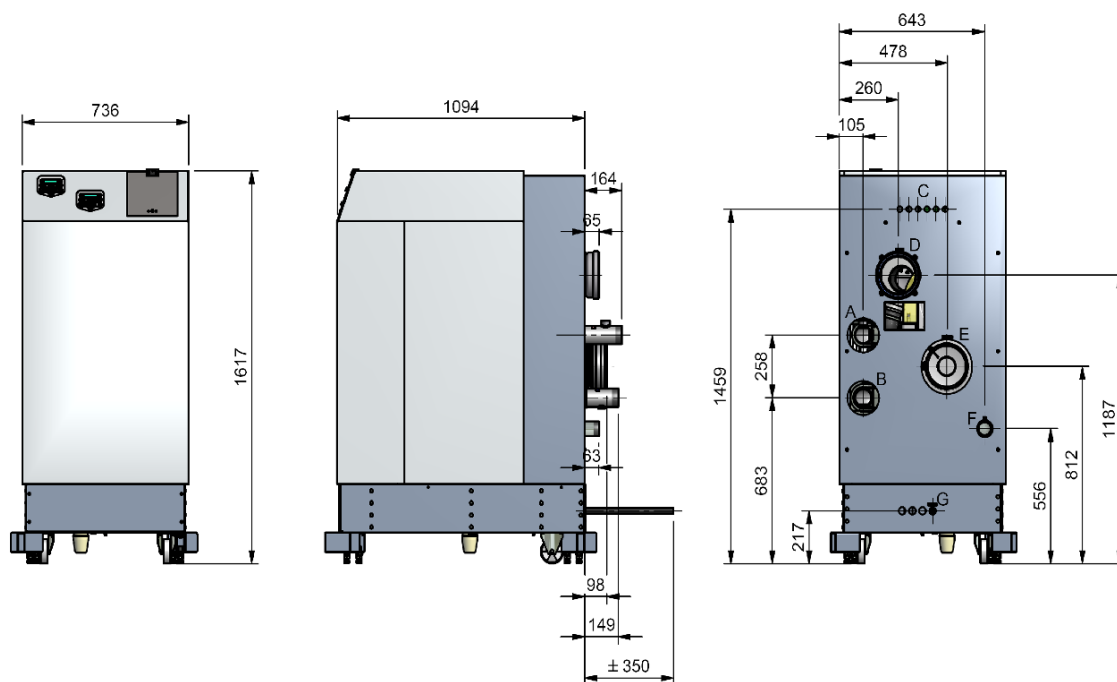

Connection	Function	Diameter (inch/mm)
A	water flow (outlet)	R 2½ "
B	water return (inlet)	R 2½ "
C	cable input	Ø 22,5 mm
D	combustion air inlet	Ø 180 mm
E	flue terminal	Ø 180 mm *
F	gas connection	R 2 "
G	condensate discharge hose	Ø 25 mm outer diameter

4 ACCESSORIES AND UNPACKING OF THE BOILER

4.1 Accessories

Depending on the selected controlling of the central heating system and the type of boiler, the following items can be ordered and delivered with the boiler:

Item	Part no.
Outside (air) temperature sensor: 12 kOhm@25°C (to be mounted to the boiler connections)	E04.016.585
External flow temperature sensor for behind the low velocity header: 10 kOhm@25°C (to be mounted to the boiler connections only needed on cascades)	E04.016.304
Calorifier temperature sensor: 10kOhm@25°C (to be mounted to the boiler connections)	E400277
Room Controller "OpenTherm" RC (modulating) with clock function	S04.016.355
Room Controller "OpenTherm" RC (modulating) with remote room sensor	S04.016.358
Interface cable and software for programming the boiler	E400278

4.2 Unpacking

The S-CB+ 400 & 550 boiler comes with the following documents and accessories:

- One "Installation manual" for the installer.
- Three spare nuts for the installation of the burner plate, one Torx key T40, one Allen key no.3 and one gas conversion sticker (all in a bag attached to the front of the gas valve).
- Bottom part of the siphon.

After delivery, immediately check if the boiler is complete and without any defects. Report any damage immediately to the supplier.

5 INSTALLATION OF THE S-CB⁺ 400 & 550

5.1 General notes

The boiler is mounted on a pallet with a wooden “support” frame around it. The boiler is wrapped in shrink wrap before the wooden support frame is mounted. After the frame is placed the whole pallet, boiler and frame package is shrink wrapped again.

Only remove this packaging when the boiler has been positioned at the place where it will be installed. After removing the wrapping and the frame, the boiler can be taken off the pallet using a forklift or another suitable lifting device. The boiler is fixed to the pallet with screws. Make sure these are removed before attempting to lift the boiler from the pallet. Also make sure that the wheels at the back are not damaged during lifting (for example by the forks of the fork lift).

Positioning

The boiler will now be positioned on the four adjustment bolts.

Ensure the boiler levels in both directions are horizontal by using these four bolts.

Side legs

The boiler has four legs at the bottom that can be turned. The following is possible with these legs:

1. If the legs will not be used, they can be turned and positioned underneath the boiler.
2. If the boiler will be anchored to the floor, these legs can be turned to the front or side and attachment can take place by using the holes in these legs
3. When the boilers are placed cascaded, the legs need to be turned sideways in a position that the following boiler can be placed and mounted. This to make sure, that all boilers are placed at the same height and with the correct distance between the boilers. Advice is to choose this distance at least 0,5 m, in view of service purposes.

5.2 Boiler room

5.2.1 GENERAL

The boiler must be positioned and installed by a certified installer in accordance with all applicable standards and regulations. Commissioning of the boilers must be done by a skilled service/commissioning engineer, who has been trained and selected by the installer and/or the manufacturer.

5.2.2 BOILER ROOM

For the installation of the boiler(s) the following demands regarding the boiler room should be considered:

1. The radiation losses of the unit are low.
2. The boiler has a built-in fan that will generate noise, depending on the heat demand. The sound emissions are quite low from the boiler, but be aware that some noise is produced.
3. You need a power supply of at least 230V-50 Hz with an earth connection and may need a supply of 400V-50Hz depending on the pump. We advise to install a separate “safe working switch on which all poles are switched” externally so one can work on the boiler while having all the wiring free of supply voltage.
4. The air supply of the boiler can be connected independent from the boiler room.

Other considerations related to the boiler location.

- The ventilation of the boiler room must meet all applicable standards and regulations, regardless of the selected supply of fresh air to the boiler location.
- The flue gas tube must be connected to an outside wall or roof duct. The air supply can may come from outside or from the plant room itself.
- The installation area must be dry and frost-free.
- There must be sufficient lighting available in the boiler room to work safely on the boiler.
- When a boiler is positioned at the highest point of the installation, the supply and return pipes must first protrude 0.5m above the top of the boiler, before these pipes go to the installation side. In other words, the water level must always be 0,5 metre above the top of the boiler and an automatic air vent must be installed in the supply or return pipe. A low-water level protection should also be installed at the installation side.
- Mind the positioning of electrical components in relation to the temperature sensitivity.
- Make sure there is an open connection with the sewer to drain the condensate. This connection should be lower than the condensate drain level of the boiler.

- Ensure that the correct space is provided when positioning the boiler for maintenance and replacement of parts. The recommended minimum clearance is:
 - Side clearance: 500 mm (advised 1000 mm)
 - Front clearance: 800 mm
 - Rear clearance: 500 mm
- Make sure that the floor on which the boiler is placed can hold the weight of the boiler.

The following facilities are needed in the technical room:

- One wall socket (electricity) with earth connection near the boiler

According to the valid standards and regulations a fire switch needs to be installed outside the boiler room; in case of emergencies the electrical power to the boiler(s) can be shut off.

5.2.3 VENTILATION

Either when the boiler is connected independently or when it takes the combustion air out of the technical room, the ventilation of the technical room needs to meet all applicable standards and regulations.

5.3 Removing the top, front and side panels

The top panel can be removed by loosening the screw on the middle of the control panel, if the top panel is removed the side and front panels can also be easily removed by lifting them up and moving them away from the boiler. These panels can only be removed if the top panel has been removed first!



5.4 Mounting the boiler

Before mounting the boiler, the installer needs to design and calculate the following parts:

- Flue gas pipe connection.
- Air supply connection.
- Flow and return connection.
- Condensate and pressure relief valve drainage.
- Power supply.
- A proper design to control the boiler (room thermostat, 0-10V etc.)



All lines/piping must be mounted free of tension. The weight of all the installation components should be supported separately from the boiler so there will be no standing force on the connections.

Don't use excessive force on the connections while mounting the boiler.

6 CONNECTIONS WATER SIDE

6.1 Boiler connections

Rear view

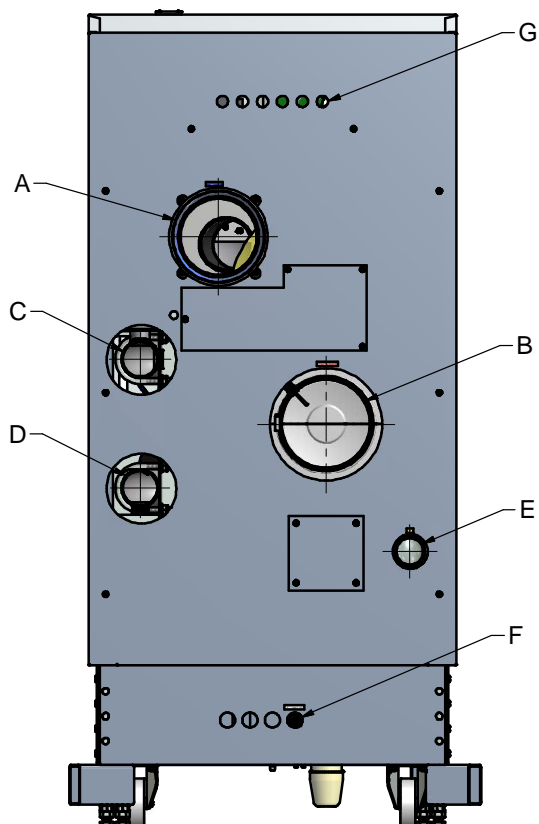

- A Air supply
- B Flue gas outlet
- C CH water flow (outlet)
- D CH water return (inlet)
- E Gas
- F Condensate discharge
- G Cable entry

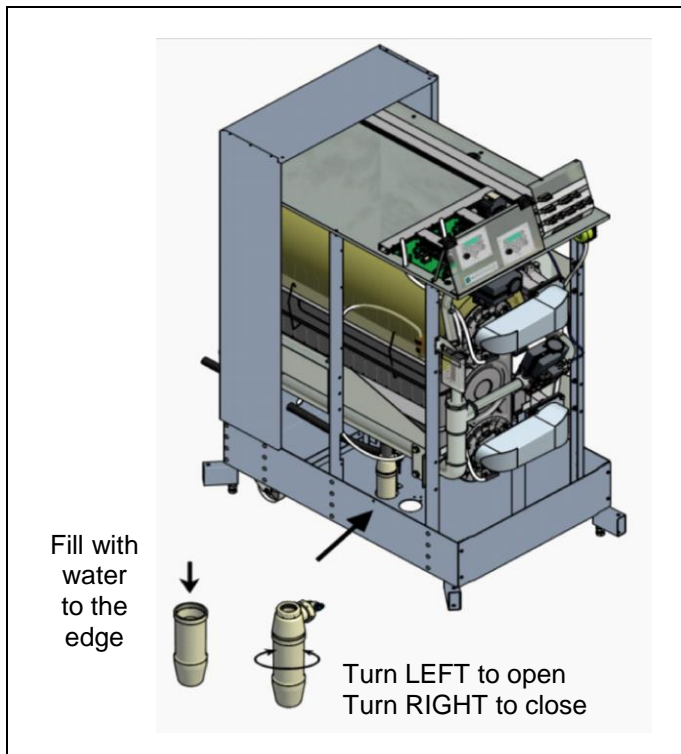

6.2 Condensate drain connection

The condensate drain is placed at the centre and at the bottom of the boiler and has a $\frac{3}{4}$ inch hose discharge. Connect this flexible hose to the sewer system.

Use only plastic parts with the condensate drain. Metal lines are not allowed.

Blockage of this drain might damage the boiler. The drain connection is correct when the condensate can be seen flowing away, e.g. using a funnel. Any damage that might occur, when the drain is not installed correctly, is not covered by the warranty of the boiler.

There should be an open connection of the condensate hose into the sewage system. A possible under pressure in the sewage system must never give the opportunity to suck on the boiler's condensate drain hose.



When mounting the bottom part of the siphon, before commissioning the boiler and/or after maintenance, the siphon must ALWAYS be completely filled with water.

This is a safety measure: the water in the siphon keeps the flue gases from entering the plant room by leaving the heat exchanger via the condensate drain.

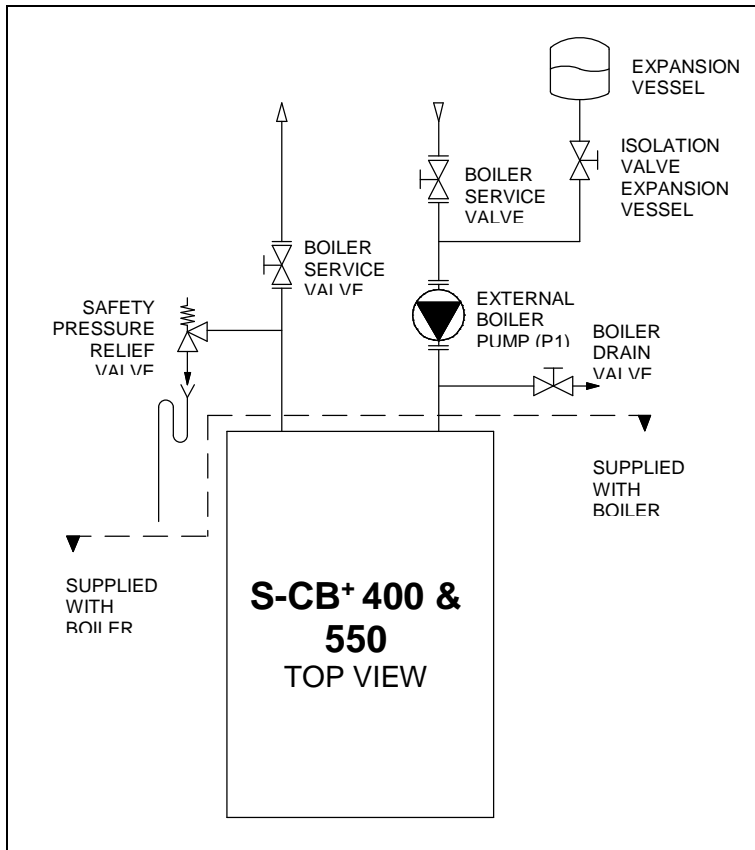

6.3 Flow and return connections

We advise to install two service valves in the flow and return pipes to the boiler, so the boiler can be isolated from the heating system, when maintenance or service needs to be carried out.

Mount the boiler pump ALWAYS in the return of the boiler.

Do not use chlorine based fluxes for soldering any pipes of the water system.

6.4 The expansion vessel

The capacity of the expansion vessel must be selected and installed to match the capacity of the central heating system and the static pressure. It is suggested you fit the expansion vessel in the return of the central heating system. It can be combined with a drain valve for service and maintenance.

6.5 Pressure relief valve

The S-CB+ 400 & 550 boiler has no internal pressure relief valve. This should be fitted in the flow line of the system near the boiler. When having multiple boilers, each boiler must have its own pressure relief valve. We advise to install service valves, so the boiler can be isolated from the heating system, when maintenance or service needs to be carried out. Make sure the pressure relief valve is mounted between the boiler and the service valves. The pressure relief valve must always be installed in such a way that it cannot be isolated from the boiler by a valve.

The specifications and size of the relief valve should be determined by the installer and must comply with all applicable standards and regulations.

6.6 Bypass

The boiler has no internal bypass. If many thermostatic valves are being used, the system should have a bypass to allow adequate flow in case all the thermostatic valves are closed.

The boiler flow will also be influenced when a pipe of the heating system is frozen/blocked. Make sure all heating pipes are free from the risk of frost. If there is the risk of freezing of the heating system, all the pipe sections must be insulated and/or protected with the help of a tracing.

Installing the boiler flow circuit in series with the heating system is possible, but not preferable. We advise to install a low loss header behind the boiler, so flow restrictions on the installation side can never influence the boiler flow. Using a low loss header prevents both before mentioned boiler threats (frost and too many thermostatic valves) and guarantees free boiler flow.

6.7 Pump functionality

The pump capacity must be determined for each project. The boiler pump (P1) can be controlled directly by connecting it to the internal relay.



The boiler pump must be controlled by the boiler controller. If, for any reason, an external pump control is applied *without written approval of Strebel*, the complete warranty on the boiler and all supplied parts will become invalid.

A safety switch for the pump motor must be installed externally (when needed) and is not included in the boiler supplies.

We supply a 230 VAC signal for controlling the external relays that will switch the system pump (P3) or the calorifier pump (P2). **Do not use these connections as a supply, always use an external relay for controlling these pumps.**

6.8 Frost protection

The boiler has a built-in frost protection, that is automatically activating the central heating pump when the boiler return (water) temperature drops below the 5°C (programmable). When the boiler return temperature drops below the 3°C (programmable), the burner is also ignited. The pump and/or burner will shut down as soon as the return temperature has reached the 10°C (programmable). The mentioned temperatures are related to the temperatures measured by the RETURN sensor of the boiler. This frost protection function will not fire up the boiler in case of a "general blocking" of the burner demand.

NOTICE: This "Frost Protection" function is only useable for the boiler and not for the whole central heating system. Because it concerns a programmable setting, a boiler damaged by frost is not covered under warranty.

6.9 Installing a strainer and/or dirt separator

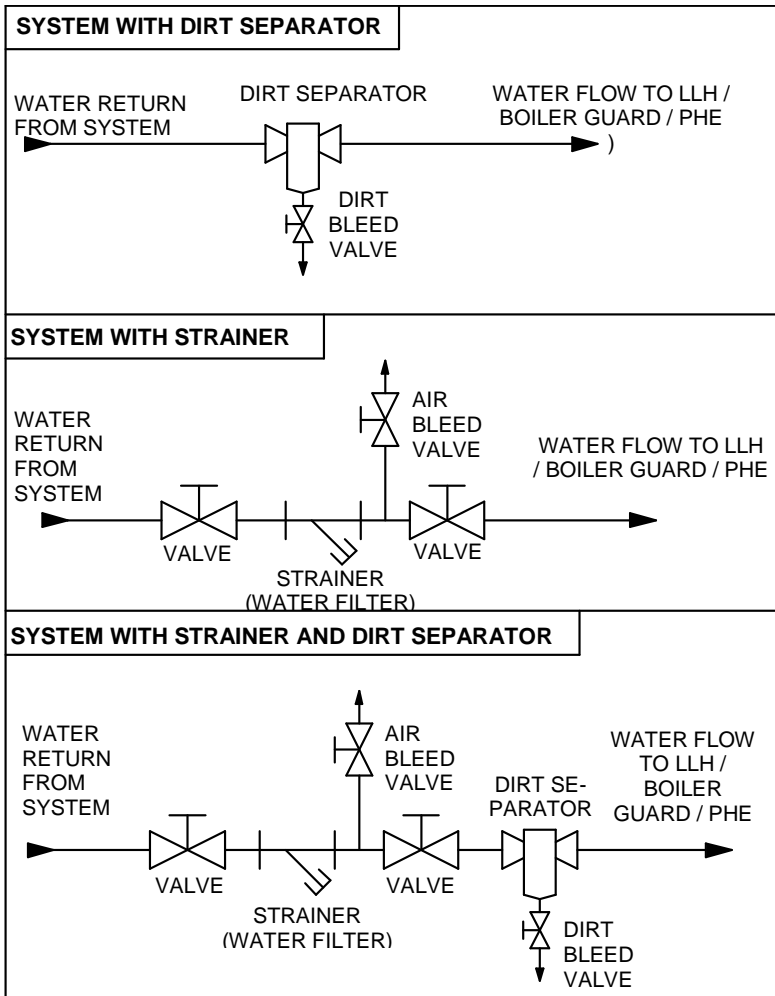

Always install a strainer (water filter) and/or a dirt separator on the system side after a low loss header / Strelboiler guard / plate heat exchanger on the return pipe pipework – not on the boiler side (primary)! This will ensure that the water going to the boiler is free of any flow restrictions. When using a water filter always check a week after installation to determine the strainer cleaning interval. Advice is to mount valves before and after the strainer, including an air bleed valve, so the strainer can be isolated from the heating circuit for service operations. Clean water is very important, blocked and/or polluted heat exchangers, including failures and/or damages caused by this blockage are not covered by the warranty.

Clean water is important, blocked and/or polluted heat exchangers, including failures and/or damages caused by this blockage are not covered by the warranty.

6.10 Water quality

The pH value of the water must be within the following limits: $7,5 < \text{pH} < 9,5$. This pH value is reached with the steady conditions. These steady conditions will occur, when after filling the heating system (pH around 7) with fresh water, the water will lose its air because of the air bleeding operation and heating up (dead water conditions).

Water hardness must be within the following limits:

$3,5^\circ \text{ Clark (50 ppm CaCO}_3) < \text{total hardness} < 10,5^\circ \text{ Clark (150 ppm CaCO}_3)$

When the water might contain aluminium particles, this should be of a maximum of 0,2 mg/litres. If there is the risk of contamination of the water by any kind of debris/chemicals in the period after installing, a plate heat exchanger should be used to separate the boiler circuit from the heating circuit (see drawing next section).

It is advised to prevent the possible air intake and water leakage of the central heating system. Fresh oxygenated water might damage the heat exchanger of the boiler and should therefore be prevented. Usual spots where air is most likely to seep in are: suction gaskets, pumps, air valve working as a venting pipe, O-rings / gaskets in stuffing box, under floor heating pipes.

6.11 Plastic piping in the heating system

When plastic pipes are used in the central heating system and **NOT** oxygen diffusion proof to standard DIN 4726, these should be separated from the boiler system by using a plate heat exchanger. Diffusion (through the plastic) can cause air to enter the heating system. This could damage the boiler, pumps and other components in the system. Be aware that plastic piping is often used in under floor heating systems. When no measures have been taken to prevent the entrance of air into the boiler system, the warranty of the boiler and any boiler part may be deemed invalid.

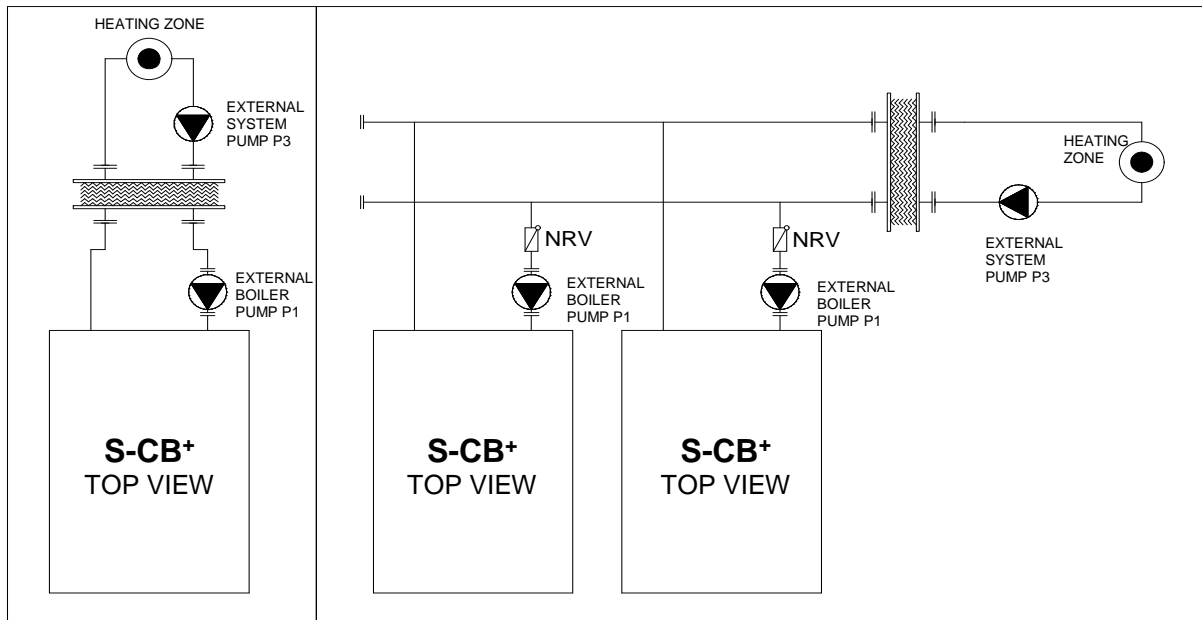

6.12 Automatic air vent

An automatic air vent is mounted on the boiler to remove the air from the water circuit.

NOTICE: this automatic air vent is only used for bleeding the air in the heat exchanger of the boiler. One or more external automatic air vent(s) and/or air separators must always be mounted in the heating system to take out the air trapped in the heating circuit.

DE-AERATION PROGRAM. When the unit is fired for the first time the unit starts a de-aeration program. One cycle is 5 seconds pump running and 5 seconds pump off. A complete de-aeration program consists out of 3 cycles. The de-aeration program can be interrupted/stopped by briefly pressing the service button during the program.

6.13 Automatic water filling systems

When using an automatic water refill system some precautions should be taken (fresh water is bringing fresh oxygen into the system), like installing a water meter to measure and evaluate the total water volume that is added to the system. This to detect and eliminate any water leakage as soon as possible.

When an automatic water refill system is used, some form of logging should take place to prevent continuously filling of the system with large amounts of oxygenated fresh water. This can happen when a leak in the system is not detected and the total added water amount is not being logged.

6.14 Water pressure

First and for all, the installation should be designed and built conform all applicable regulations and standards, including the right safety valves. IMPORTANT: Always keep the pressure in the boiler lower than the value at which its safety valve opens.

Sensor

A water pressure sensor has been built into the boiler. With this sensor, minimum water pressure in the boiler is 0,8 bar and maximum pressure is up to 4,0 bar (sensor values). Normal water pressure is supposed to be between 1,5 and 2,0 bar.

The pressure sensor will stop the boiler from firing when the water pressure drops below 0,8 bar, and start the boiler firing again when the water pressure reaches above the 1,0 bar. These values can be changed in the boiler control settings.

Higher pressure systems (e.g. in high buildings)

If pressures higher than 4,0 bar occur in the heating system, the best solution is to separate the system from the boiler by means of a plate heat exchanger. Now the boiler pressure can still be under 4,0 bar and the boiler control remains as described above.

Without plate heat exchanger, above 4,0 bar, a water pressure switch has to be built into the boiler instead of the water pressure sensor - the maximum allowed value in the boiler now is 6,0 bar and the boiler control needs to be adjusted.

6.15 Chemical water treatment

The chemical compatibility of several products for treatment of the central heating equipment has been tested on the heat exchangers and the boilers. A list with the corrosion inhibitors in preventative and curative treatment for gas fired central heating boilers can be supplied.

6.16 Under floor heating

When using an under-floor heating system of non-diffusion proof PVC pipes, the boiler circuit must be separated from the heating circuit by means of a plate heat exchanger.

6.17 Flush the system with fresh water

The water of the boiler and heating circuit should be free of any particles, debris and pollution. Therefore, the complete installation must always be thoroughly flushed with clean water before installing and using the boiler(s).

6.18 Installation examples

6.18.1 INSTALLATION CONTAINING ONE S-CB+ 400 / 550 CH BOILER









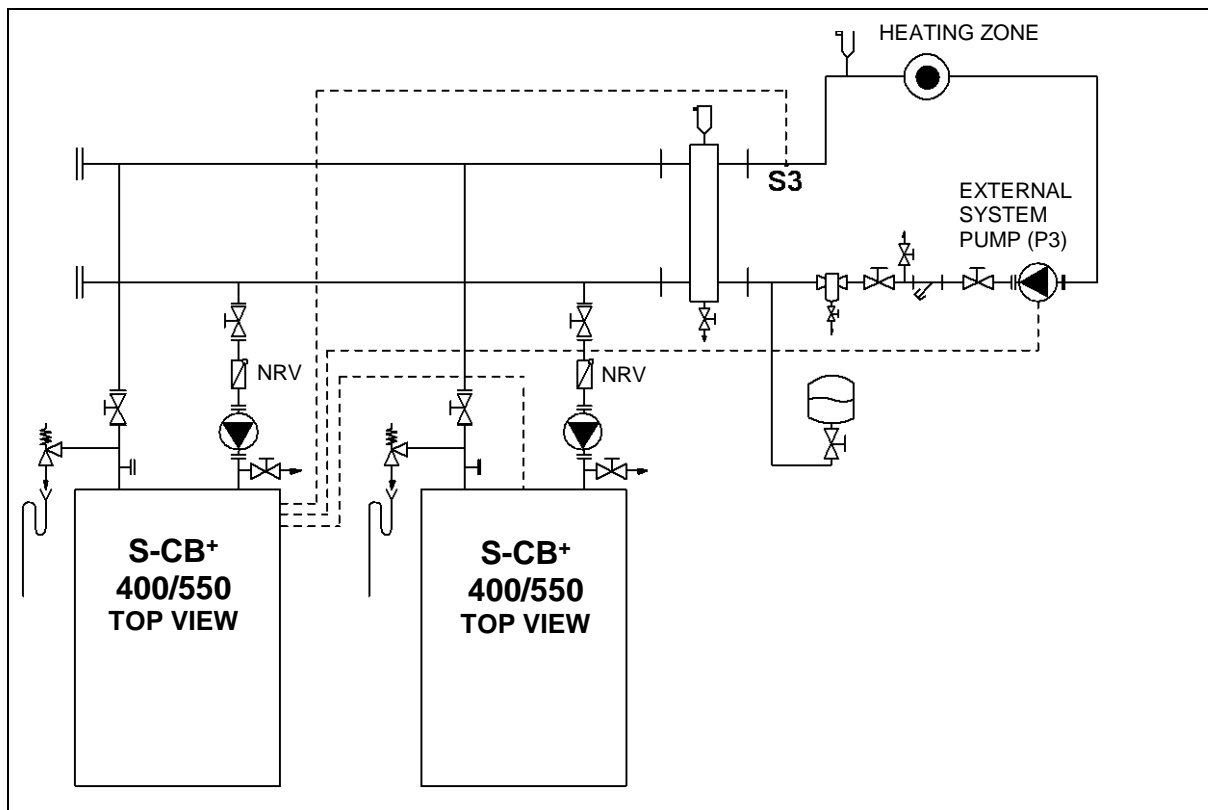

EXTERNAL SYSTEM PUMP can be controlled by the boiler. Often the system pump is externally controlled and always running. System pump needs to run when boiler is firing.

With the low loss header the boiler flow is not influenced by system behaviour. We advise to use a low loss header.

	valve
	air separator
	dirt separator
	strainer (water filter)
	pressure relief valve
	siphon
	pump
	automatic air vent
	expansion vessel
	low loss header

6.18.2 INSTALLATION CONTAINING TWO S-CB+ 400/550 CH BOILERS USING NON-RETURN VALVES



	valve		siphon		low loss header
	air separator		pump		
	dirt separator		automatic air vent		
	strainer (water filter)		expansion vessel		
	pressure relief valve		non-return valve - use low resistance type:		

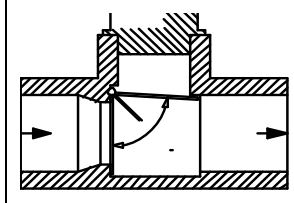

7 HYDRAULIC GRAPHS

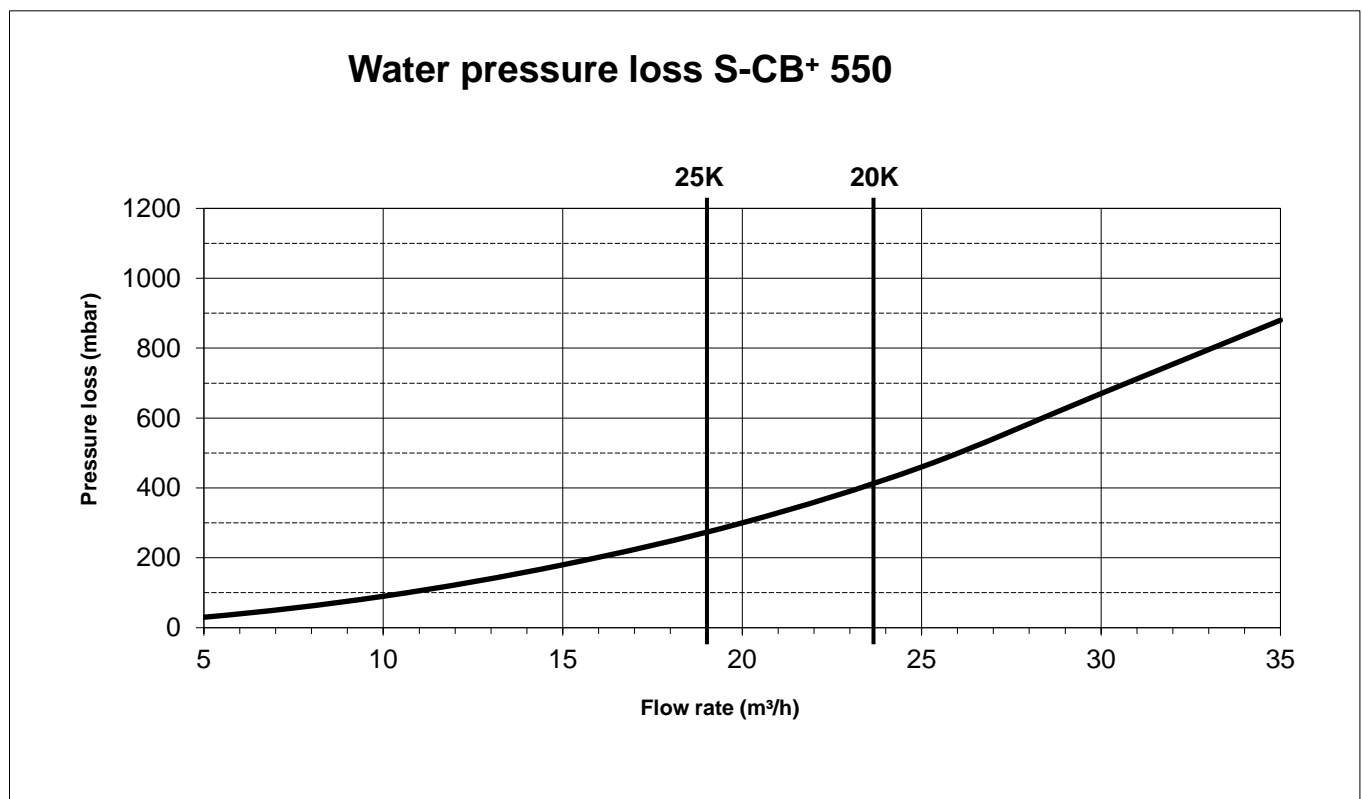
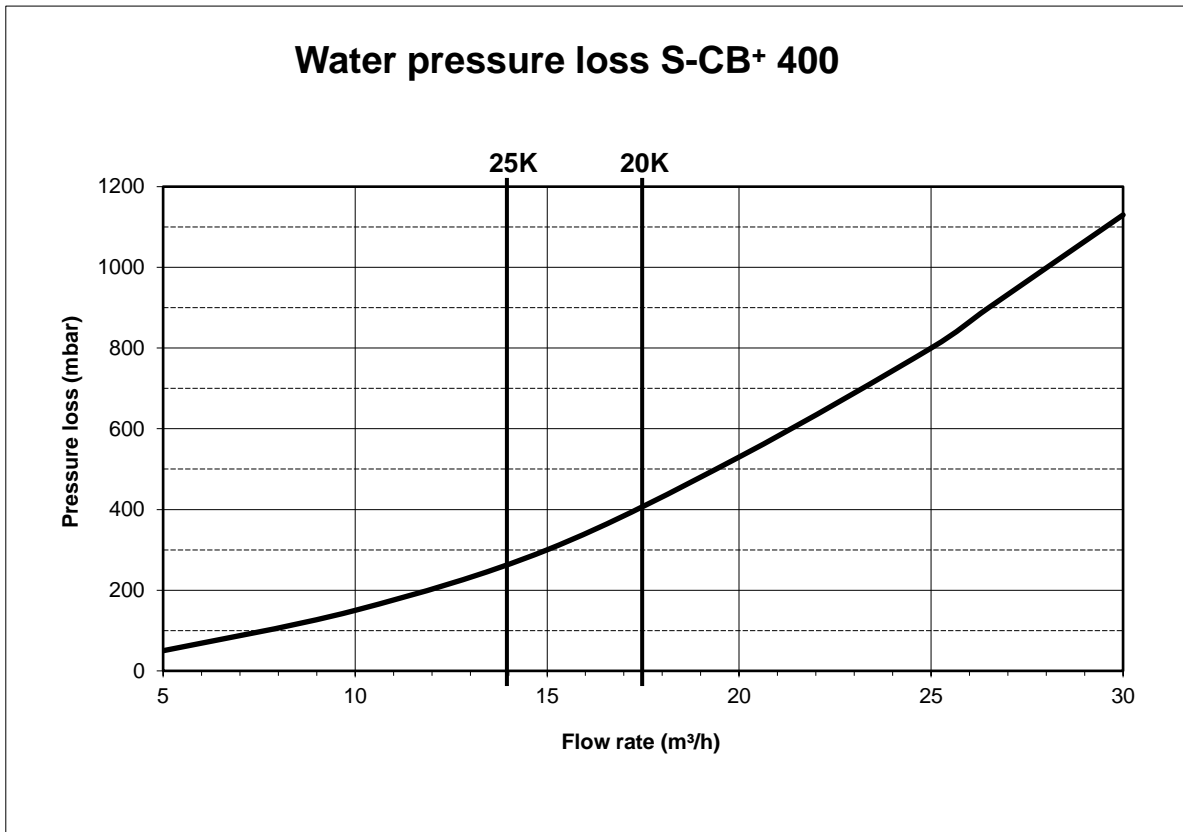

- The design flow should be right for ΔT between 25K and 20K.
- The pump must be selected for each project and is not part of the standard boiler supply.

8 FLUE GAS AND AIR SUPPLY SYSTEM

8.1 General

The boiler must be commissioned and installed by a skilled installer in accordance with all applicable standards and regulations.

The overall resistance of the air supply and flue terminal must **not exceed a pressure drop of 200 Pa**. For installation values see the table in section 8.8.2.

The S-CB+ 400 & 550 CH boilers have a flue terminal diameter of Ø180 mm and an air supply diameter of Ø180 mm.

Note.

Because the flue gases can have a relatively low temperature, the boiler needs to have a high efficiency approved stainless steel or plastic flue system. These materials should be usable for the applied pressure in the flue gas system, be condensate proof and have a temperature class of **T120**. Never use aluminium (containing) flue gas materials for this boiler.

8.2 Flue gas system

The flue terminal duct must be made of stainless steel, temperature class **T120**.

Note.

Because the flue gases can have a low temperature, the boiler needs to have a high efficiency approved stainless steel flue system. The material should be usable for positive pressure flue gas systems and have a temperature class of **T120** or better.

Multiple boilers can be connected to a common duct. These flue gas systems for multiple boiler installations must always be engineered as zero or negative pressure systems; this to prevent the risk of recirculation of the flue gases. Consult the flue gas supplier for detailed information and engineering.

8.3 Boiler categories - types of flue gas systems.

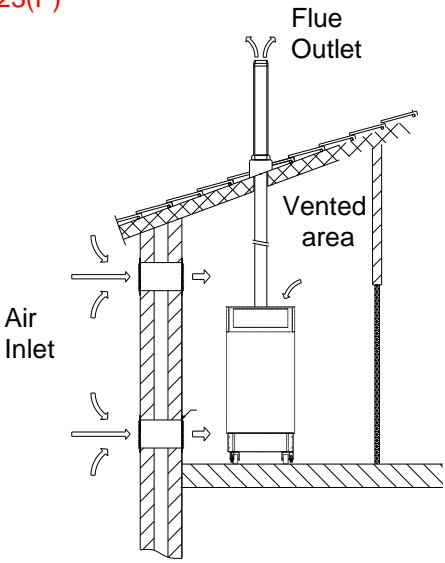
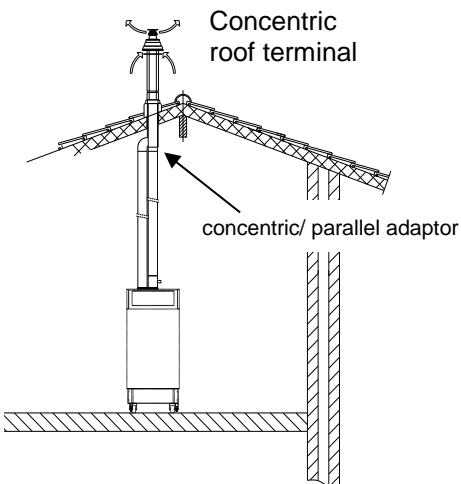
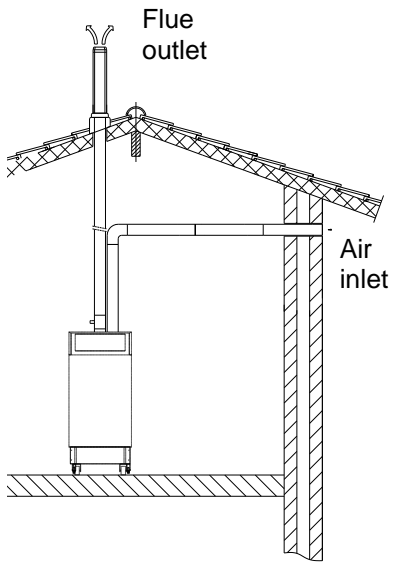
Type according EN 15502-2-1: 2012	Performance	Description
<p>B23(P)</p>  <p>Flue Outlet</p> <p>Vented area</p> <p>Air Inlet</p>	<p>Open</p> <p>Air supply from room</p>	<ul style="list-style-type: none"> * Roof terminal * Without draught diverter * Boiler room air supply. * P = overpressure systems <p>Be aware: The installation room has to have sufficient air supply vents. These vents must be open and may not be closed or blocked.</p> <p>Requirements at NEN 3028 paragraph 6.5</p> <p>Use table 4.2 to select the right parts.</p>
<p>C33</p>  <p>Concentric roof terminal</p> <p>concentric/ parallel adaptor</p>	<p>Closed</p> <p>Air supply from outside</p>	<ul style="list-style-type: none"> * Flue terminal at the roof. * Air supply inlet and flue gas outlet located at the same air pressure zone (a combined roof terminal e.g.). <p>When used with separated air supply and flue gas outlet the outlets have to be within a square of: 100 cm</p> <p>And the distance between the planes of the two transits must be smaller as: 100 cm</p> <p>Use table 4.2 to select the right parts</p>
<p>C53</p>  <p>Flue outlet</p> <p>Air inlet</p>	<p>Closed</p> <p>Air supply from outside</p>	<ul style="list-style-type: none"> * Separate air supply duct * Separate flue gas discharge duct. * Air supply inlet and flue gas outlet at different air pressure zones. But not at opposite walls. <p>Use table 4.2 to select the right parts</p>

C63

Flue outlet
Air inlet

Closed
Air supply from outside

* Appliance sold without flue/air-inlet ducts.
* The flue gas parts are not part of the boiler. The boiler is intended to be connected to a separately approved and marketed system for the supply of combustion air and discharge of combustion products.
Condensate is allowed to go to the boiler.
* Air supply inlet and flue gas outlet not at opposite walls
* Technical data:

nominal $T_{flue\ gas}$	85°C
nominal $Q_{fluegas}$	see 2.2 ¹⁾
maximum $T_{fluegas}$	95°C
min. load $T_{fluegas}$	35°C
min. load $Q_{fluegas}$	see 2.2 ¹⁾
nominal % CO_2	see 2.2 ¹⁾
max. allowed draft	70Pa
max. pressure drop inlet-outlet	200Pa
max $T_{air\ supply}$	40°C
max recirculation	10%

1) table technical specifications

Use the conditions of chapter 8.4 to select the right parts.

8.4 C63 certified

In general, boilers are certified with their own flue gas material. For type **B23(P)**, **C13**, **C33**, **C43**, **C53** and **C83** systems, only use flue gas and air supply parts approved according chapter 4.2.

If a heater is C63 certified, no specific type flue gas material has been certified in combination with the boiler. In this case the flue gas and air supply parts should comply with the applicable European standards (EN14989). So, for type C63 systems flue gas and air supply parts from other suppliers can be used. It must be able to handle the condensate forming (W) and transport, overpressure (P1) and must have a minimum temperature class of **T120**. Also, it has to meet the requirements in the following chapters "air supply" and "flue terminal".

CE string flue gas material	European standard	Temperature class	Pressure class	Resistance to condensate	Corrosion resistance class	Metal: liner specifications	Soot fire resistance class	Distance to combustible material	Plastics: location	Plastics: fire behaviour	Plastics: enclosure
min. req. PP	EN 14471	T120	P1	W	1		O	30	I of E	C/E	L
min. req. SS	EN 1856-1	T120	P1	W	1	L20040	O	40			

A few examples of flue gas material suitable for the S-CB⁺ boilers:

- CE String for Plastic PPs: EN14471 T120 P1 W 2 O(30) I C/E L
- CE String for Stainless Steel: EN1856-1 T250 P1 W V2-L50040 O (50)

When selecting flue gas systems, be aware that the minimum requirements are met. So only select flue gas materials having the same or better properties than this table.



Never use aluminium containing flue gas pipes in these boilers.

Connecting diameters and tolerances:

mat	d_{nom}	$D_{outside}$	L_{insert}	d_{inside}	L_{insert}	$d_{wall\ thickness}$
RVS	180	$180 \pm 0,3$	50 ± 1	$181,2 \pm 0,3$	$50 +0/- 2$	$0,6 \pm 10\%$
RVS	200	$200 \pm 0,3$	50 ± 1	$201,2 \pm 0,3$	$50 +0/- 2$	$0,6 \pm 10\%$
PP	200	$200 +1/- 0,6$	$50 +20/- 2$	$202 +0,6/- 1$	$50 +20/- 2$	$\geq 3,5$

8.5 *Flue Terminal*



Never use aluminum containing flue gas materials for this boiler range

The flue terminal duct can be made of:

- Stainless steel in combination with **T120** gaskets.
- PP temperature class **T120**.

8.5.1 VERTICAL FLUE TERMINAL POSITIONING

Please refer to the relevant British Standards:

- BS 6644 – Installation of gas fired hot water boilers of rated inputs between 70kW – 1.8MW.

Please refer to the Institution of Gas Engineers and Manager Documents (IGEM):

- IGEM/UP/10 Edition 4 – Installation of gas fired hot water boilers of rated inputs between 70kW – 20MW.

8.5.2 COMMON FLUE / DUCTS

Multiple boilers can be connected to a common duct. These flue gas systems for multiple boiler installations must always be engineered as zero or negative pressure systems; this to prevent the risk of recirculation of the flue gases. **In circumstances where a zero or negative pressure cannot be achieved, please call Strebel Ltd Technical Department for advice.**

8.6 *Air supply*

If an air supply duct is connected from outside the building to the boiler, the boiler will operate as a room-independent boiler (closed boiler).

The supply duct can be made of:

- PVC
- Thin-walled aluminium
- Stainless steel

The air supplied for the boiler room ventilation shall be such that the maximum temperatures within the boiler house shall be:

- 25°C at floor level (or 100mm above floor level);
- 32°C at mid-level (1.5m above floor level); and
- 40°C at ceiling level (or 100mm below ceiling level).

8.6.1 AIR QUALITY

Combustion air must be free of contaminants. For example: chlorine, ammonia and/or alkali agents, dust, sand and pollen. Notice that installing a boiler near a swimming pool, a washing machine, laundry or chemical plants does expose combustion air to these contaminants.

If the combustion air is taken from the boiler room, the inlet air must be clean and free of water. Always use a wire mesh to prevent debris being drawn into the air inlet

8.6.2 AIR SUPPLY THROUGH HUMID AREAS

When the supply duct is installed in a boiler room with humid air (for example: greenhouses), a double wall supply duct or an insulated duct should be considered to prevent condensation on the outside of the duct. It is not possible to insulate the internal air pipes of the boiler. Make sure that no condensate can be formed on the internal air canals.

The air supply duct must be protected against rain, when it is installed on top of the roof.

8.7 Pipe heights and mutual distances on a flat roof.

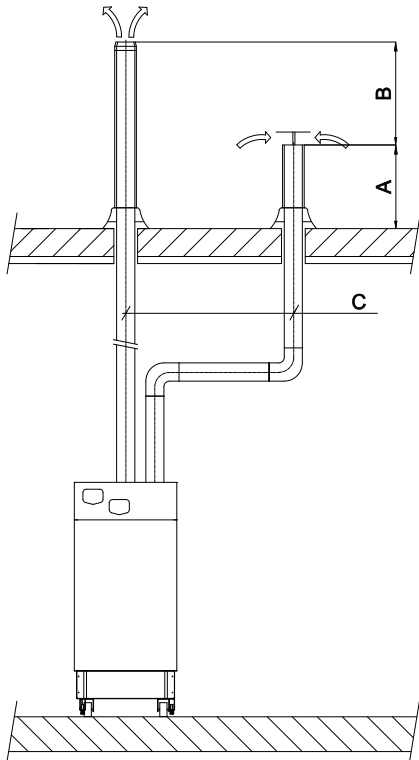

Height A

This is the height of the air inlet that must have a cap to prevent rainwater entering the system.

When in- and outlet are mounted on a flat roof, the inlet should be at least 60 cm above the roof surface and at least 30 cm above the maximum snow level.

Example 1:

When the maximum snow level on the roof surface is 45 cm then height A should be $45 + 30 = 75$ cm. This is more than 60 cm so this height should be 75 cm.

Example 2:

When the maximum snow level on the roof surface is 15 cm then height A should be at least $15 + 30 = 45$ cm. This is less than 60 cm, so the height should be 60 cm.

Height difference B

This should be at least 70 cm: the flue gas outlet should be at least 70 cm higher than the air inlet and should be equipped with a conical outlet.

A single flue outlet on a flat roof should stick out at least 100 cm from the roof surface.

Distance C – mutual horizontal distance at roof level

This should be at least 70 cm.

8.8 S-CB+ 400 & 550 air inlet / flue gas outlet calculation examples

The load of the boiler is influenced by the resistance of the air supply and the discharge system. The diameter and length of both air supply and flue gas pipes needs to be designed accurately to decrease the possible power loss of the boiler.

Calculation examples

In the following, five calculation examples are given for determining the maximum length of the flue gas and air supply pipes.

A: Twin pipe system with separate pipes for flue gas and air supply.

Air supply roof mounted.

B: Single pipe system for flue gas outlet only.

Air supply from boiler room.

C: Twin pipe system with separate pipes for flue gas and air supply.

Air supply wall mounted.

D1 and D2: Twin pipe system with concentric flue gas outlet - air inlet.

8.8.1 FLUE GAS AND AIR SUPPLY RESISTANCE TABLE - CONCENTRIC PARTS

Just one specific concentric roof terminal has been measured and approved to be used with the S-CB+ 400 and 550. Below mentioned values concerns only this specific concentric roof terminal. An eccentric adapter has to be used at the flue gas outlet of the boiler to avoid moisture agglomeration. See example D in chapter 8.7.6

Flue gas	Ø [mm] *	resistance [Pa]	
		S-CB+ 400	S-CB+ 550
Concentric roof terminal	200 / 300	56,5	106,6
Condensate trap	200	3,7	6,6
Flue gas eccentric adapter	180>200	0,9	1,7

Air inlet	Ø [mm] *	resistance [Pa]	
		S-CB+ 400	S-CB+ 550
Concentric roof terminal	200 / 300	28,6	54,0
Concentric adapter air supply	180>200	4,3	7,6

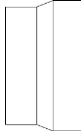
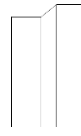
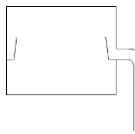
Concentric flue gas outlet and air inlet parts	
Concentric roof terminal	
Air supply concentric adapter	
Flue gas excentric adapter	
Condensate capture	

8.8.2 TWIN PIPE FLUE GAS AND AIR SUPPLY RESISTANCE TABLE:

Flue gas piping	Ø [mm] *	Resistance [Pa]	
		S-CB+ 400	S-CB+ 550
straight tube/m	180	3,0	-
	200	1,8	3,0
	250	-	1,0
T-piece vertical boiler outlet (T-piece horizontal use values 45° elbow)	180	25,5	-
	200	16,7	29,7
	250	-	12,2
90° elbow	180	9,9	-
	200	6,5	11,6
	250	-	4,7
45° elbow	180	5,7	-
	200	3,7	6,6
	250	-	2,7
flue outlet open zeta = 0,0	180	0,0	-
	200	0,0	0,0
	250	-	0,0
flue outlet conical zeta = 0,05	180	1,4	-
	200	0,9	1,7
	250	-	0,7
flue outlet H/D = 1,0 zeta = 1,0	180	28,3	-
	200	18,6	33,0
	250	-	13,5
flue outlet H/D = 0,5 zeta = 1,5	180	42,4	-
	200	27,8	49,6
	250	-	20,3

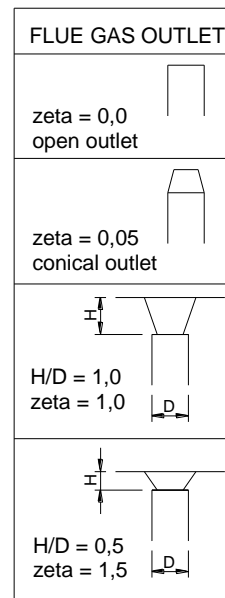

Air supply piping	Ø [mm] *	Resistance [Pa]	
		S-CB+ 400	S-CB+ 550
straight tube/m	180	2,1	3,5
	200	1,3	2,1
	250	-	0,7
T-piece vertical boiler inlet (T-piece horizontal use values 45° elbow)	180	26,7	47,4
	200	17,5	31,1
	250	-	12,8
90° elbow	180	7,5	13,3
	200	4,9	8,7
	250	-	3,6
45° elbow	180	4,3	7,6
	200	2,8	5,0
	250	-	2,0
air inlet H/D = 1,0 zeta = 1,0	180	21,3	38,0
	200	14,0	24,9
	250	-	10,2
air inlet mesh ½" x ½" zeta = 1,3	180	27,7	49,3
	200	18,2	32,4
	250	-	13,3

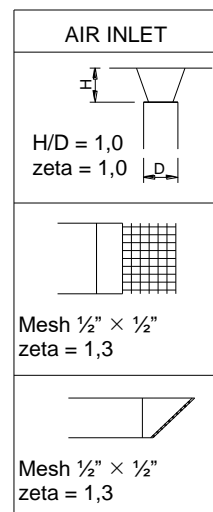

* Do not reduce the pipe diameter relative to the boiler connection

This table may only be used for **SEPARATE** flue gas/air systems and NOT for common flue (collector) systems for multiple cascaded boilers.

8.8.3 EXAMPLE A: TWIN PIPE SYSTEM

Calculation example:

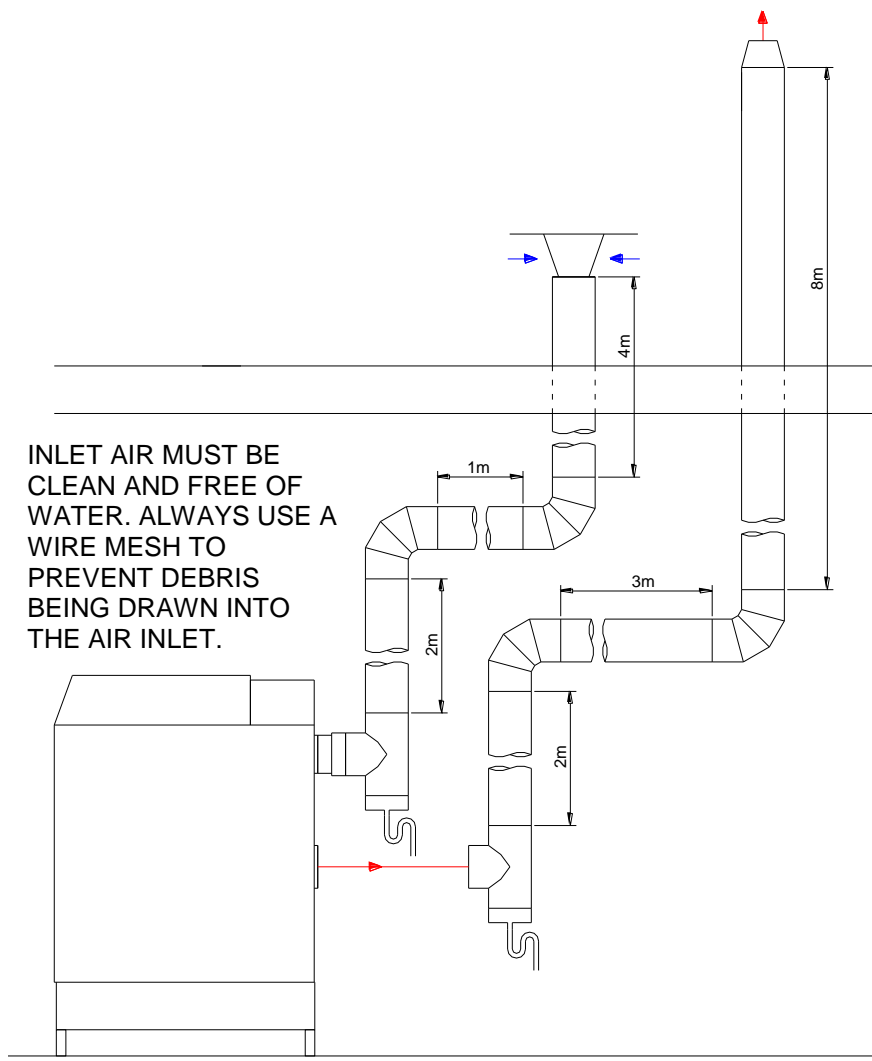

Boiler type:		S-CB+ 400		
Flue gas	Diameter: 200 mm.	Number	Pa	Pa total
	Straight tube m ¹ total	13	1,8	23,4
	T-piece outlet	1	16,7	16,7
	Bend 90°	2	6,5	13
	Flue outlet Zeta=0,05	1	0,9	0,9
Total resistance flue gas outlet:				54,0
Air supply	Diameter: 200 mm.	Number	Pa	Pa total
	Straight tube m ¹ total	7	1,3	9,1
	T-piece inlet	1	17,5	17,5
	Bend 90°	2	4,9	9,8
	Air inlet Zeta=1,0	1	14,0	14,0
Total resistance air supply:				50,4
Total resistance flue gas outlet and air supply:				104,4 Pa

The total resistance is less than 200 Pa, so this is acceptable.

8.8.4 EXAMPLE B: SINGLE PIPE SYSTEM FOR FLUE GAS OUTLET ONLY

Calculation example:

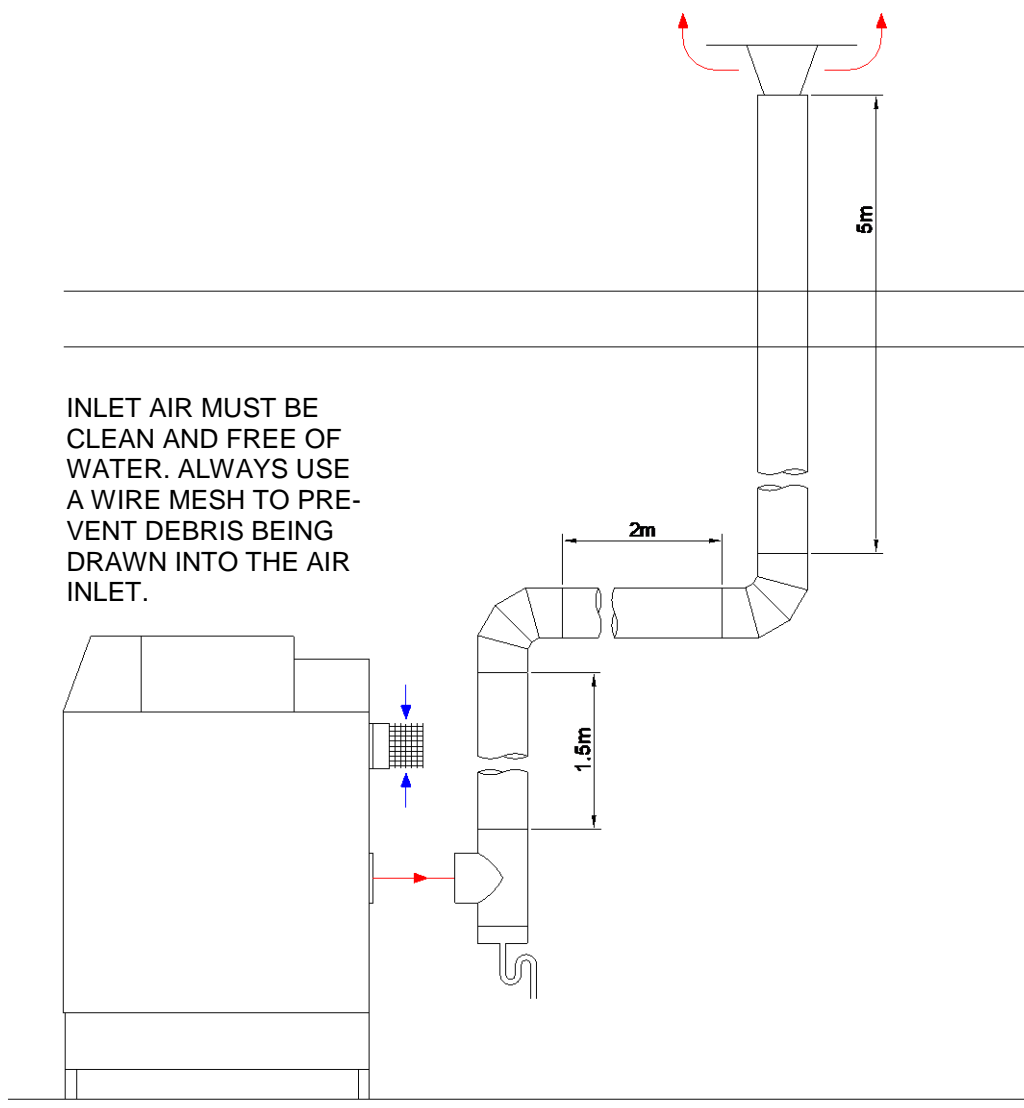

Boiler type:		S-CB+ 400			
Flue gas	Diameter: 180 mm.		Number	Pa	Pa total
	Straight tube	m ¹ total	8,5	3,0	25,5
	T-piece	outlet	1	25,5	25,5
	Bend	90°	2	9,9	19,8
	Flue outlet	Zeta=1,0	1	28,3	28,3
Total resistance flue gas outlet:					99,1
Air supply	Diameter: 180 mm.		Number	Pa	Pa total
	Air inlet	Zeta=1,3	1	27,7	27,7
Total resistance air supply:					27,7
Total resistance flue gas outlet and air supply:					126,8 Pa

The total resistance is less than 200 Pa, so this is acceptable.

8.8.5 EXAMPLE C: TWIN PIPE SYSTEM WITH WALL MOUNTED AIR DUCT.

Calculation example:

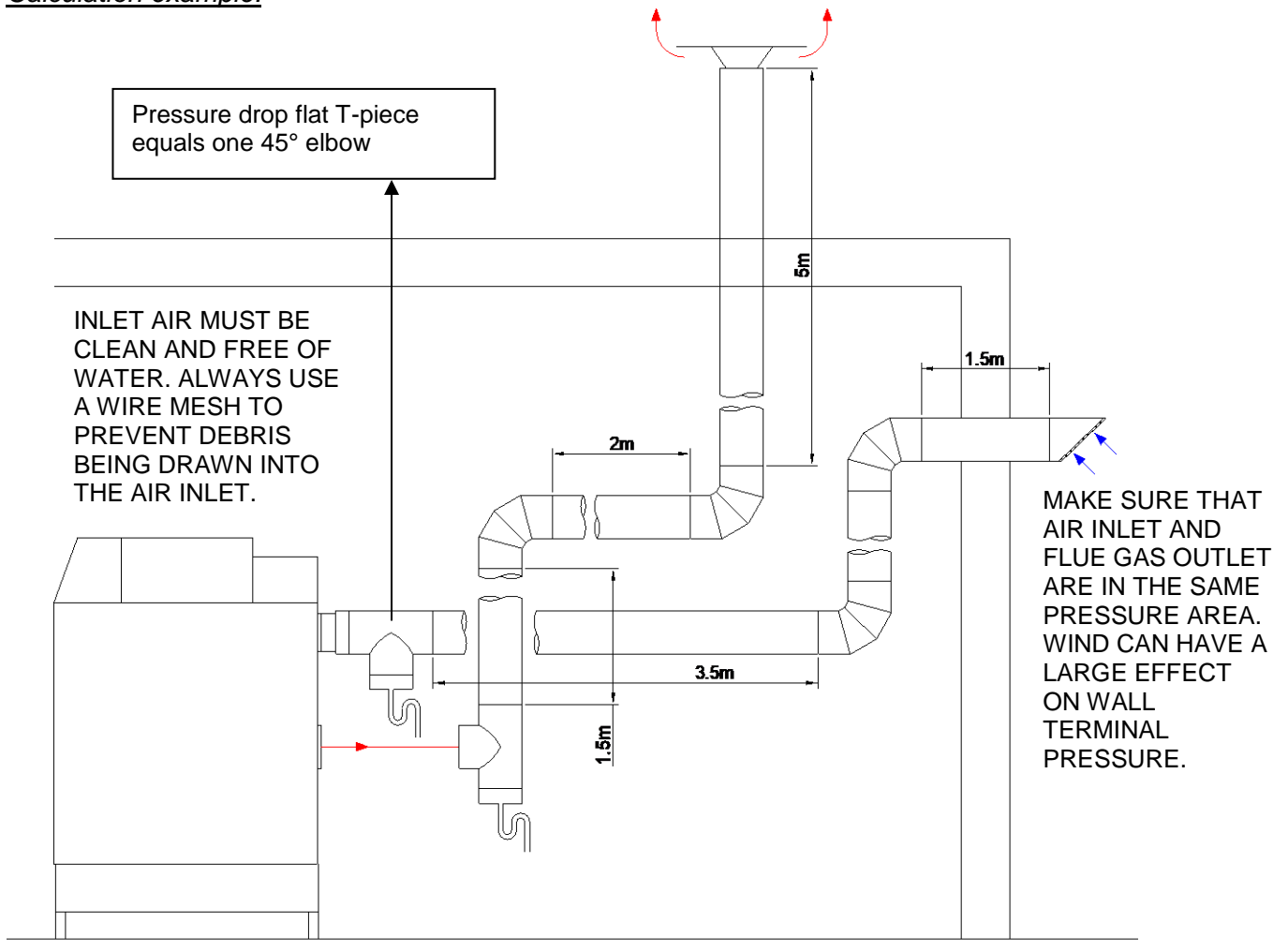

Boiler type:		S-CB+ 550			
Flue gas	Diameter: 250 mm.		Number	Pa	Pa total
	Straight tube m ¹	total	8,5	1,0	8,5
	T-piece	outlet	1	12,2	12,2
	Bend	90°	2	4,7	9,4
	Flue outlet	Zeta=1,5	1	20,3	20,3
Total resistance flue gas outlet:					50,4
Air supply	Diameter: 250 mm.		Number	Pa	Pa total
	Straight tube m ¹	total	5	0,7	3,5
	T-piece	inlet	1	2,0	2,0
	Bend	90°	2	3,6	7,2
	Air inlet	Zeta=1,3	1	13,3	13,3
Total resistance air supply:					26,0
Total resistance flue gas outlet and air supply:					76,4 Pa

The total resistance is less than 200 Pa, so this is acceptable.

The example calculation is only valid using the concentric roof terminal.

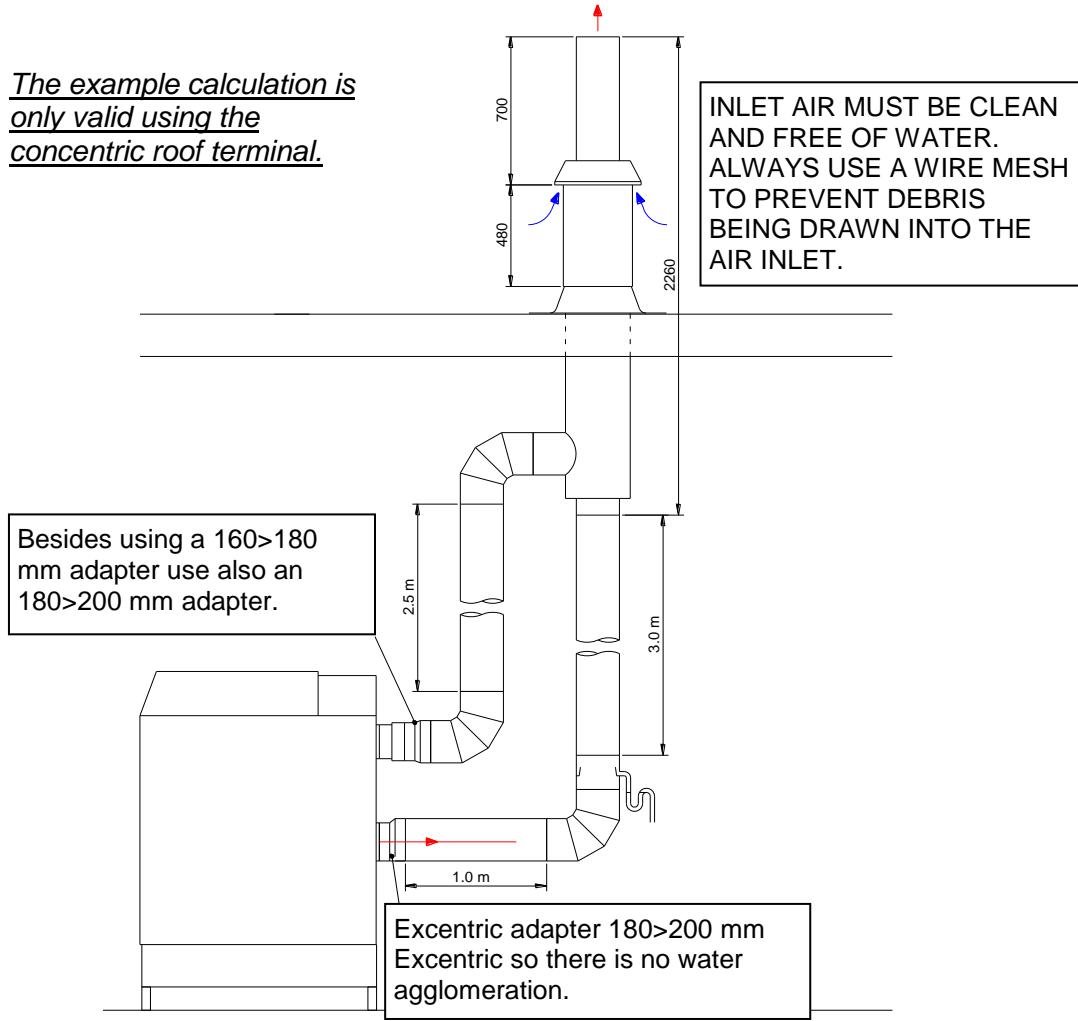

Boiler type:		S-CB+ 550			
Flue gas	Diameter: 200 mm.		Number	Pa	Pa total
	Straight tube m ¹	total	4	3,0	12,0
	Bend	90°	1	11,6	11,6
	Adapter eccentric		1	1,7	1,7
	Condensate trap		1	6,6	6,6
	Conc. roof terminal 200-300 M&G		1	106,6	106,6
Total resistance flue gas outlet:					138,5
Air supply	Diameter: 200 mm.		Number	Pa	Pa total
	Straight tube m ¹	total	2,5	2,1	5,3
	Bend	90°	2	8,7	17,4
	Adapter 180-200		1	7,6	7,6
	Conc. roof terminal 200-300 M&G		1	54,0	54,0
Total resistance air supply:					84,3
Total resistance flue gas outlet and air supply:					222,8

The total resistance is less than 250 Pa, so this is acceptable.
 (The maximum allowed pressure is increased to 250 Pa when using a concentric roof terminal).

The example calculation is only valid using the concentric roof terminal

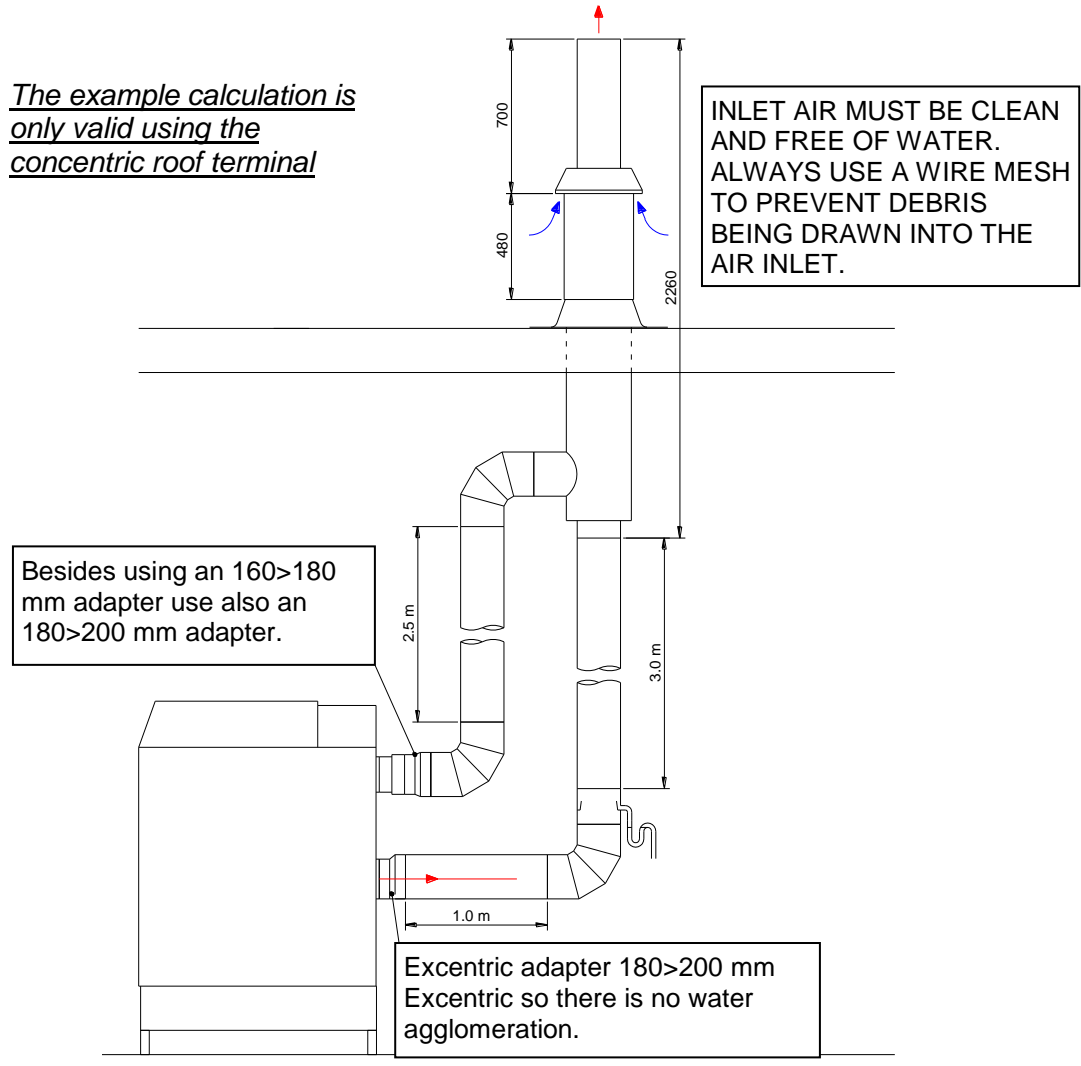

Boiler type:		S-CB+ 400			
Flue gas	Diameter: 200 mm.		Number	Pa	Pa total
	Straight tube m ¹	total	4	1,8	7,2
	Bend	90°	1	6,5	6,5
	Adapter eccentric		1	0,9	0,9
	Condensate trap		1	3,7	3,7
	Conc. roof terminal 200-300 M&G		1	56,5	56,5
Total resistance flue gas outlet:					74,8
Air supply	Diameter: 200 mm.		Number	Pa	Pa total
	Straight tube m ¹	total	2,5	1,3	3,25
	Bend	90°	2	4,9	9,8
	Adapter 180-200		1	4,3	4,3
	Conc. roof terminal 200-300 M&G		1	28,6	28,6
Total resistance air supply:					45,95
Total resistance flue gas outlet and air supply:					120,75

The total resistance is less than 250 Pa, so this is acceptable.
 (The maximum allowed pressure is increased to 250 Pa when using a concentric roof terminal).

8.9 Separate air supply and flue terminal for a pitched roof

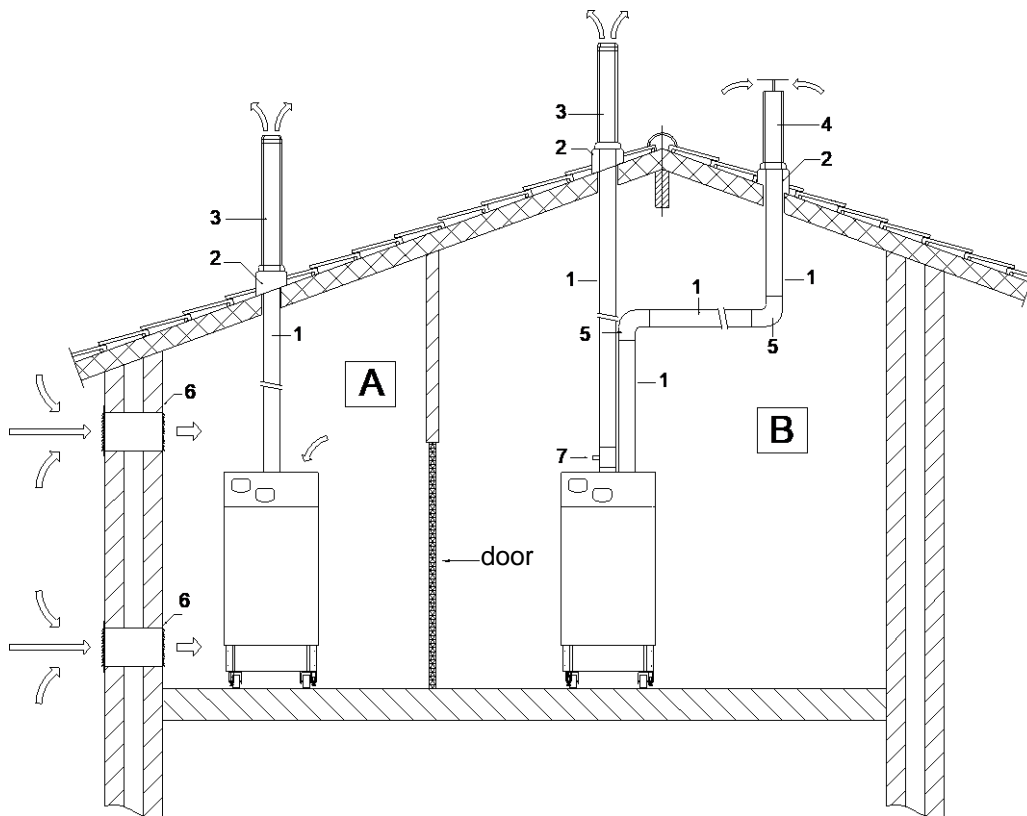

- 1 Connection tube.
- 2 Pitched roof adhesive flashing.
- 3 Flue gas roof terminal.
- 4 Air inlet roof duct.
- 5 90° bend.
- 6 Ventilation grill.
- 7 Condense water drain.

8.10 Separate air supply and flue terminal for a flat roof

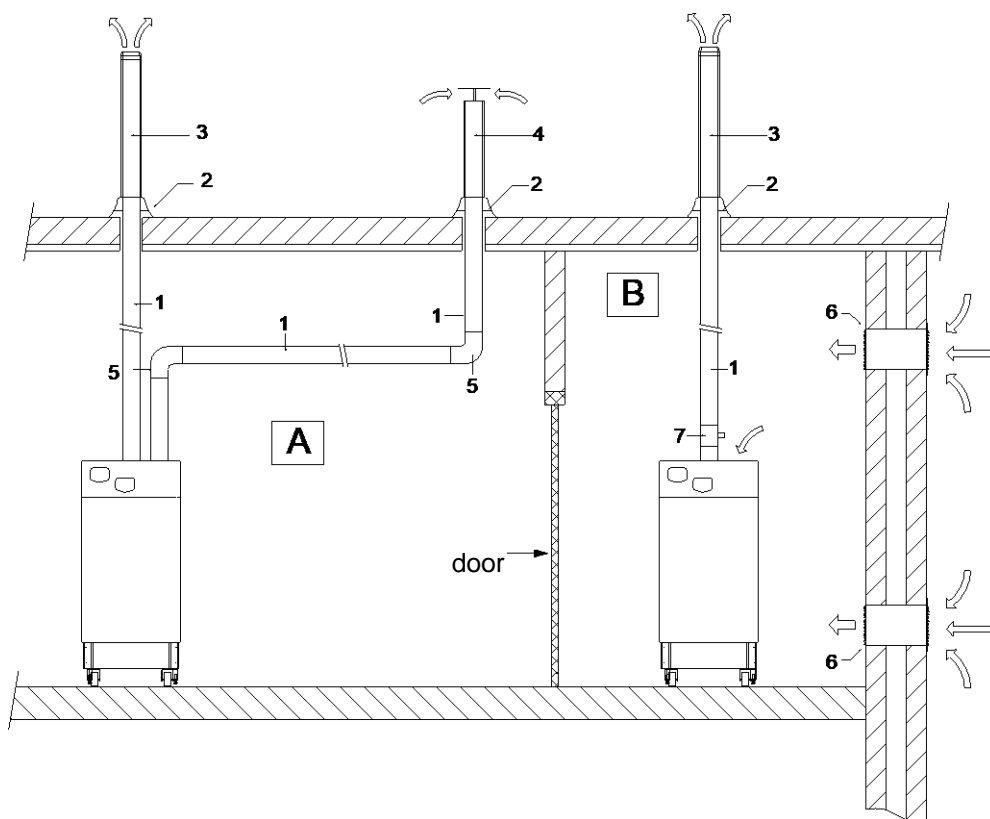

- 1 Connection tube.
- 2 Adhesive flashing for flat roof.
- 3 Flue gas roof terminal.
- 4 Air inlet roof duct.
- 5 90° bend.
- 6 Ventilation grill.
- 7 Condense water drain.

9 ELECTRICAL INSTALLATION

9.1 General

All the wires are connected to a separate connector that is fitted in a socket. The connector can be taken out from the sockets without loosening the wiring. The connections are placed next to the display panel and can be easily accessed through the hatch on the front panel by loosening the screw shown on the picture:



After entering the boiler with the power supply cable(s) on the rear side of the boiler use the left conduit to extend them to the power connections and pump relay of the boiler.
For signal cables only low voltage, use the right conduit to connect them to the connectors on the front side.



The boiler pump must be controlled by the boiler control. If, for any reason, an external pump control is applied *without written approval of Strebel*, the complete warranty on the S-CB+ 400/550 boiler and all supplied parts will become invalid.

- For operation the boiler needs a power supply of at least 230 VAC / 1~ / 50 Hz and depending on the selected pump type 400 VAC / 3~ / 50 Hz.
- The boiler connections are not life/neutral sensitive (the boiler is not phase-sensitive).
- The wiring to the connections can be entered at the rear of the boiler through the cable glands, the cable conduit has to be used there is one for power supply and one for signal cables.
- NOTICE: Before starting to work on the boiler, it must be switched off and the power supply to the boiler must be disconnected.
- Electrical wiring should be installed according to all applicable standards.
- Working on the boiler should only be done by a qualified service engineer that is skilled in working on electrical installations and according to all applicable standards.

9.2 Connections

The following components can be connected to the boiler; see the figure below.
For voltages from 110V to 250V use the left conduit and for low voltage use the right conduit.

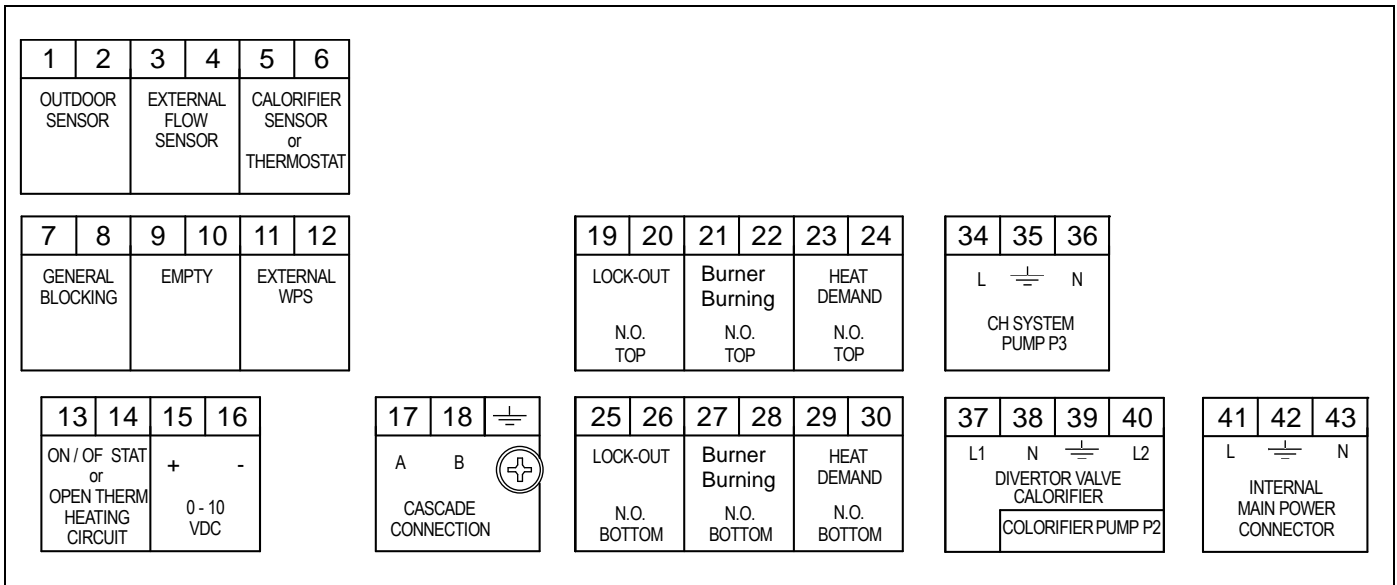

9.3 Cascaded connection including shielding

When boilers are cascaded we advise to use a shielded cable to suppress any radiated signals. Be sure that the shielding of the cable is connected to the screw on the front panel next to terminal 18. Advice is to connect the shielding only to one boiler to prevent ground loops that may affect the signal. When connecting cascade cable to the terminals be sure that the right wire is connected to the right terminal: terminals 17 and 18 may not be swapped.

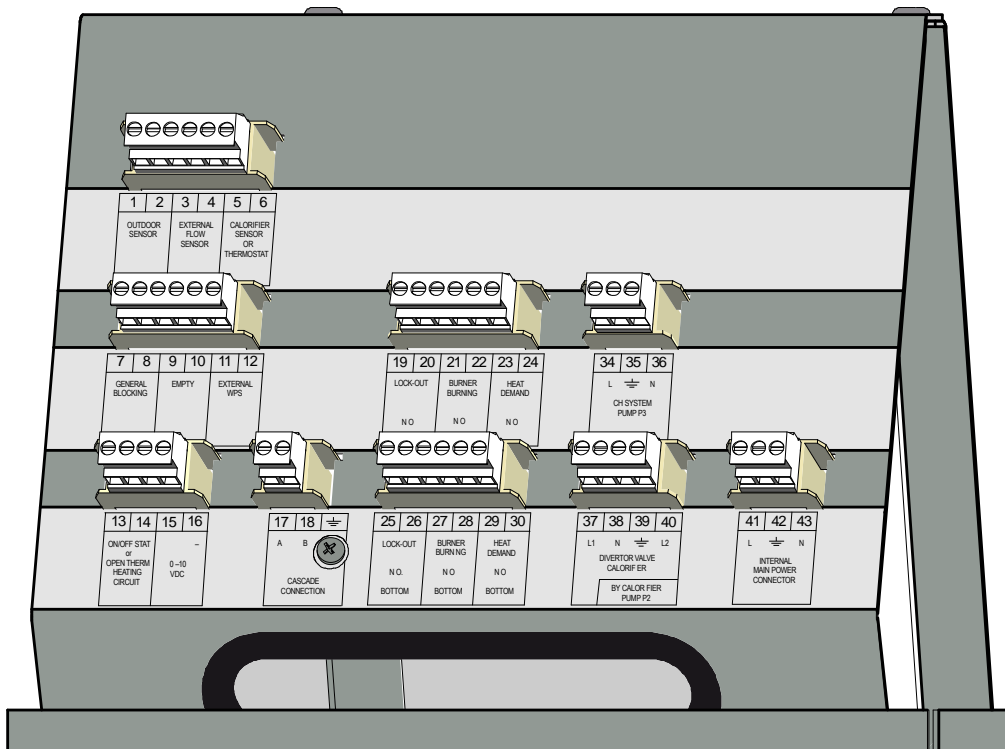

9.4 Connecting the power supply and boiler pump P1, 230V/1~ or 400V/3~

- Connect the power supply to the connecting block on the front top side of the unit. See figure below.
- A 230V/1~ pump must be connected to the relay besides the power supply connectors, according to the top figure below.
A 400V/3~ pump must be connected to the relay besides the power supply connectors, according to the bottom figure below.
- Connection of the 230 V AC power supply to the control panel has already been mounted in the factory.
- Preferably an external isolation switch should be connected to work safe on the boiler. The connection needs to be fused with a maximum 16 A fuse.
- When a pump motor safety circuit is required, this should be added externally from the boiler. Another option is to use a pump with an internal electronic safety circuit. Maximum operational switch current for the pump relay is 9 A per phase.

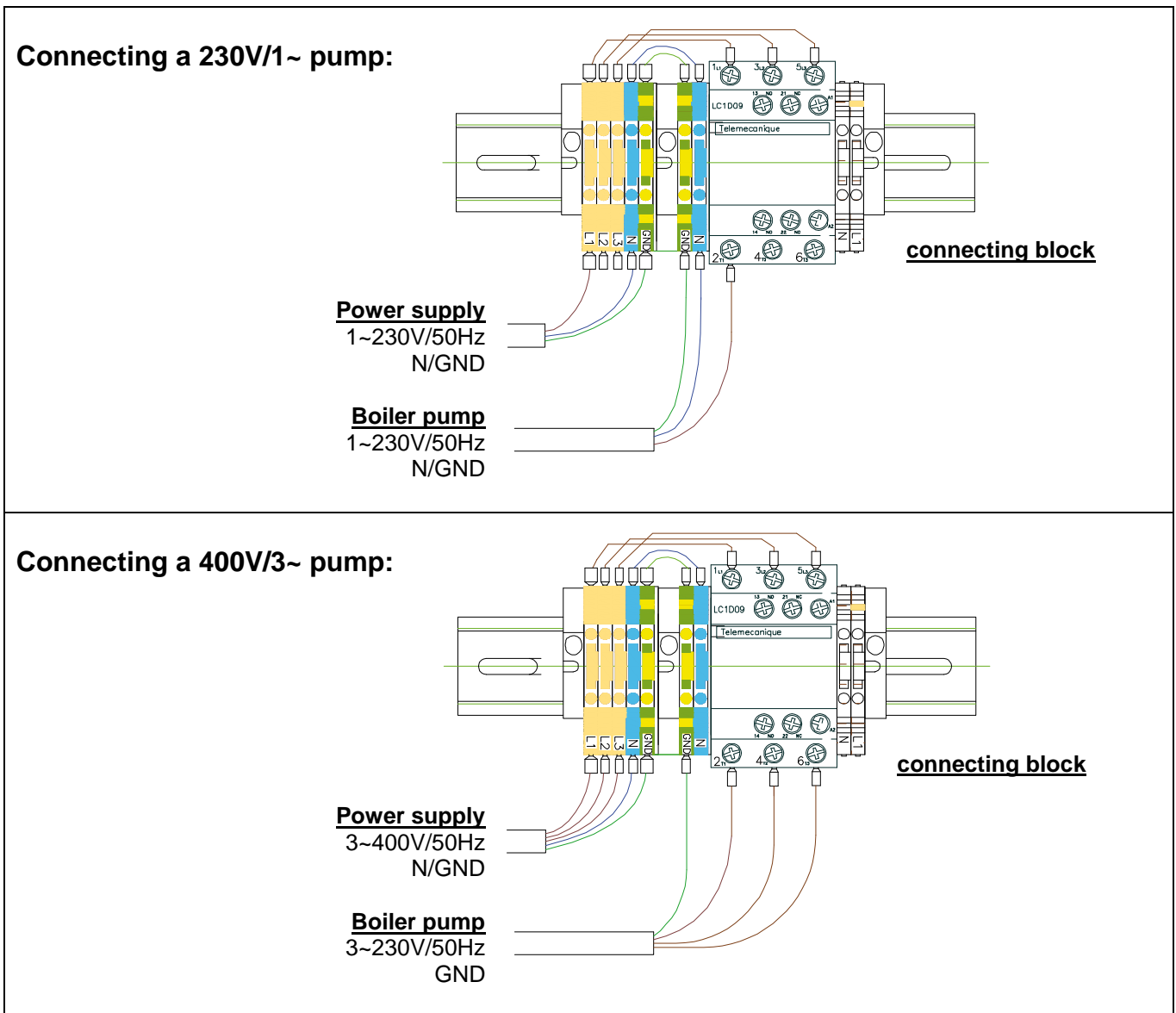

All electrical connections must be installed according to all applicable regulations.

CAREFUL: When the boiler is switched off, electrical power might still be present at the connectors and relay shown above. We advise to add an external service switch to shut off all the power to the boiler while working on it.

9.5 Fuses

The four fuses of the S-CB+ 400/550 are located on the PCBs: two fuses on each circuit board.

Fuse no.	Application	Fused value	Fuse type
F1	Pump 1 Pump 2 / TWV	250 VAC 5AT H	5 AT ceramic filled fuse
F2	Switch mode supply Gas valve Pump3 External ignition	250 VAC 5AT H	5 AT ceramic filled fuse

These boilers are not phase sensitive.

9.6 List for connections

1-2	OUTDOOR SENSOR
When an outside temperature sensor is connected, the boiler will control the flow water temperature by using a calculated setting, which is relative to the outside temperature. PARAMETER: No parameter settings needed.	
3-4	EXTERNAL FLOW SENSOR
When a low velocity header is used, this external flow sensor measures the flow temperature at the system side. The sensor must be mounted on the supply pipe at the system side, just behind the low loss header. NOTICE: The sensor must be used when several boilers are cascaded with the internal cascade manager. PARAMETER: No parameter settings needed.	
5-6	CALORIFIER SENSOR or THERMOSTAT
When an indirect hot water tank / calorifier is installed, a hot water sensor must be connected to these terminals. In case of a DHW heat demand, the set point will be shown in the display. An external on/off thermostat can also be connected to these terminals. When there is heat demand (terminal 5 and 6 are bridged) the flow temperature going to the heating coil(s) will be shown in the display.	
7-8	GENERAL BLOCKING
A heat demand that will start the burner will be blocked when terminals 7 and 8 are not bridged. This connection is for the use of external safety devices (Terminals must be bridged for allowing burner to fire). PARAMETER: A parameter change is needed.	
9-10	EMPTY
11-12	EXTERNAL WATER PRESSURE SWITCH
A water pressure sensor is mounted in the boiler. As an option a water pressure switch can be installed. The sensor can be replaced by the water pressure switch, which can be wired to the terminals. When terminals 11-12 are not bridged, the boiler will lock-out. PARAMETER: A parameter change is needed (P4AD).	
13-14	ON/OFF STAT OR OPENTHERM HEATING CIRCUIT
OPTION 1: An ON/OFF thermostat can be connected. The boiler will use the set/programmed flow temperature for the heating system when these terminals 13 and 14 are bridged. OPTION 2: When using an OpenTherm (OT) controller connected to the terminals 13 and 14. The boiler software will detect and use this OpenTherm signal automatically.	
15-16	0-10 VDC CONTROL SIGNAL
These terminals are used for an external 0-10 VDC control signal. PARAMETER: A parameter change is needed. NOTICE: Terminal 15 [+] (positive) and Terminal 16 [-] (negative).	
17-18	CASCADE CONNECTION
These connections are used when boilers are cascaded with the internal cascade manager for controlling the total cascade. NOTICE: Connect all terminals 17 and all terminals 18 together, do not switch between these terminals. <i>Use only shielded cable to connect the next boiler!</i>	

19-20	LOCK-OUT TOP OR PUMP ON/OFF
This contact is N.O. (normally open max. 230 Vac, 0,8 A). When the unit is in lock-out this contact will close. This contact can also be used for the switching of a pump with a separate control input connection, in which case a parameter change is needed.	
21-22	BURNER BURNING TOP OR EXTRA BOILER OR PUMP ON/OFF
This contact is N.O. (normally open max. 230 Vac 0,8 A). When the unit starts the burner and detects the flame, this contact will be closed. This contact can also be used to control an external (extra) boiler or for the switching of a pump with a separate control input connection; in the latter cases, a parameter change is needed.	
23-24	BURNER DEMAND TOP OR PUMP ON/OFF
This contact is N.O. (normally open max. 230 Vac 0,8 A). When the unit receives any heat demand this contact will close. This contact can also be used for the switching of a pump with a separate control input connection, in which case a parameter change is needed.	
25-26	LOCK-OUT BOTTOM
This contact is N.O. (normally open max. 230 Vac 0,8 A). When the unit is in lock-out this contact will close.	
27-28	BURNER BURNING BOTTOM
This contact is N.O. (normally open max. 230 Vac 0,8 A). When the unit starts the burner and detects the flame, this contact will be closed. This contact can also be used to control an external (extra) boiler (PARAMETER: A parameter change is needed).	
29-30	BURNER DEMAND BOTTOM
This contact is N.O. (normally open max. 230 Vac 0,8 A). When the unit receives any heat demand this contact will close.	
34-35-36	CH SYSTEM PUMP P3
Connection to control a central heating system pump (P3). Do not use this connection for the power supply of this pump, use an external relay.	
37-38-39-40	DIVERTOR VALVE CALORIFIER
When using a calorifier/hot water tank, a 3-way valve or a pump (P2) can be used to divert hot water to the heating coil of the calorifier/tank. This 3-way valve will open, when the hot water storage tank/calorifier has a heat demand. PARAMETER: A parameter change is needed. 37 = L1 wire (heating position); 38 = Neutral wire; 39 = Ground wire; 40 = L2 wire (hot water position).	
38-39-40	CALORIFIER PUMP P2
When using a calorifier/hot water tank, a 3-way valve or a pump (P2) can be used to divert hot water to the heating coil of the calorifier/tank. This pump will start when the hot water storage tank/calorifier creates a hot water demand. PARAMETER: A parameter change is needed. Do not use this connection for direct control of this pump- use an external relay.	
41-42-43	INTERNAL MAIN POWER CONNECTOR
<p>WARNING: Do not connect the main power supply to this connector! Mains should be connected to the connecting block as shown on page 40.</p> <p>CONNECTOR: with this power supply interruption plug 41-42-43 the power supply of the unit can be interrupted. Use this connector for test runs and servicing.</p> <p>41 = phase wire; 42 = ground wire; 43 = neutral wire.</p> <p>Careful! After interrupting this plug there will still be voltage on some parts of the system. <i>We advise to install a separate isolation switch (that switches off all poles) externally so one can work on the boiler while having all the wiring free of supply voltage.</i></p>	

9.7 Sensors

The following temperature sensors have been fitted in the boiler (S1 and S2 on the rear / right-side of the heat-exchanger and one for each burner):

- S1** = Flow temperature sensor (orange wire)
- S2** = Return temperature sensor (green wire)
- S3** = External flow temperature sensor
- S4** = Calorifier/tank temperature sensor (if connected)
- S5** = Outside temperature sensor (if connected)
- S6** = Flue sensor (white wire)

- (S3')** = if terminals S3 are not connected, the average value of S1 top and S1 bottom is taken and this value will be displayed.

The sensors used in the boilers are of the NTC (negative temperature coefficient) type and have the following properties:

SENSOR	SENSOR TYPE	SENSOR VALUE
S1	Internal flow sensor	NTC-10K-B3977
S2	Internal return sensor	NTC-10K-B3977
S3	External flow sensor	NTC-10K-B3977
S4	Calorifier/tank sensor	NTC-10K-B3977
S5	Outdoor sensor	NTC-12K-B3740
S6	Flue gas sensor	NTC-10K-B3975

Conversion table temperature vs. resistance except outside sensor. NTC-10k B3977 (B3975)

Temperature (°C)	Resistance (Ω)	Temperature (°C)	Resistance (Ω)	Temperature (°C)	Resistance (Ω)	Temperature (°C)	Resistance (Ω)
-30	175203	20	12488	70	1753	120	387
-25	129289	25	10000	75	1481	125	339
-20	96360	30	8059	80	1256	130	298
-15	72502	35	6535	85	1070	135	262
-10	55047	40	5330	90	915	140	232
-5	42158	45	4372	95	786	145	206
0	32555	50	3605	100	677	150	183
5	25339	55	2989	105	586	155	163
10	19873	60	2490	110	508	160	145
15	15699	65	2084	115	443	165	130

Conversion table temperature vs. resistance outside sensor. NTC-12k B3740

Temperature (°C)	Resistance (Ω)	Temperature (°C)	Resistance (Ω)
-50		0	36130
-45		5	28600
-40		10	22800
-35		15	18300
-30	171800	20	14770
-25	129800	25	12000
-20	98930	30	9804
-15	76020	35	8054
-10	58880	40	6652
-5	45950	45	5522

9.8 Electrical circuit diagram Top burner (PCB A, left)

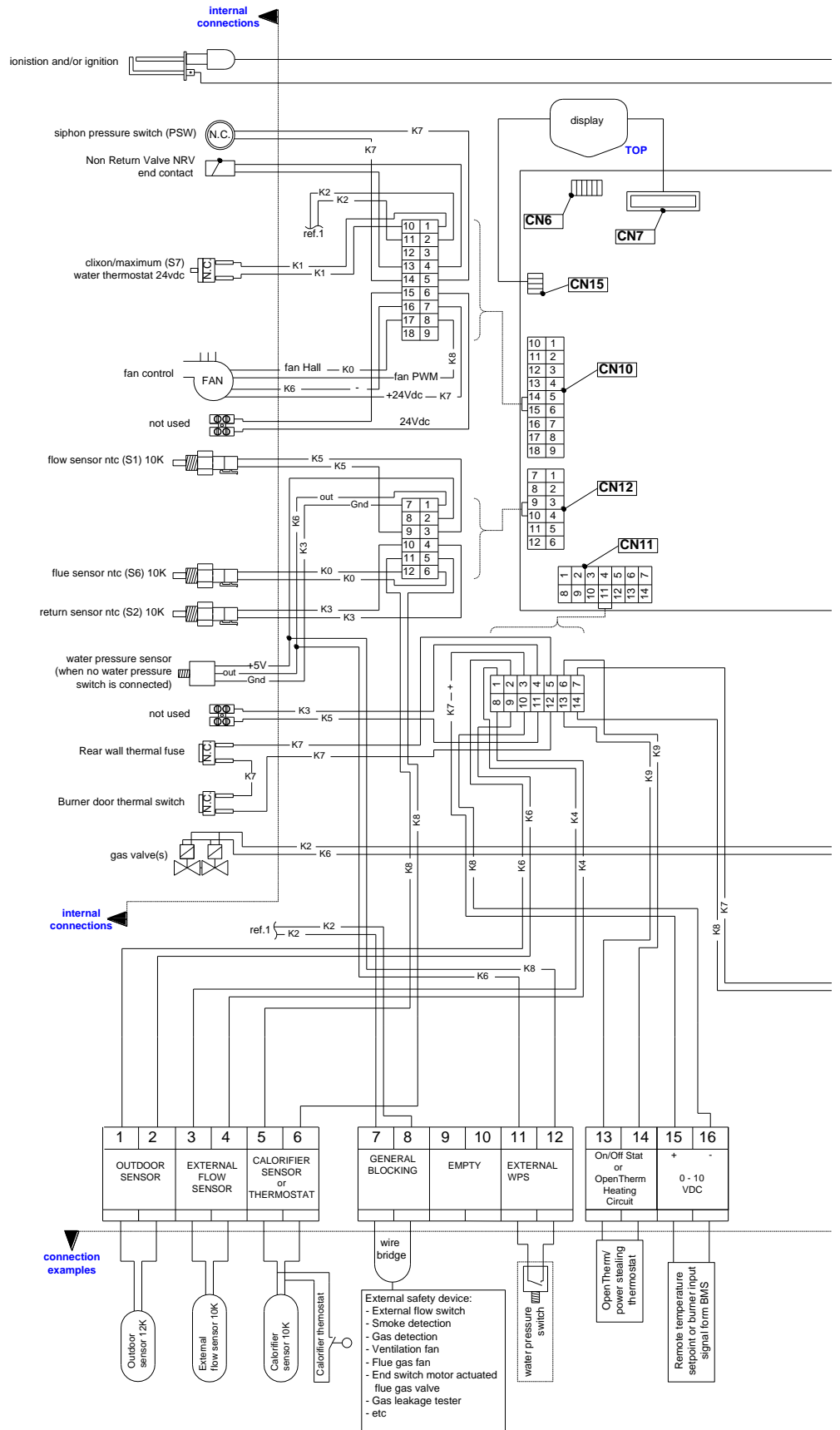

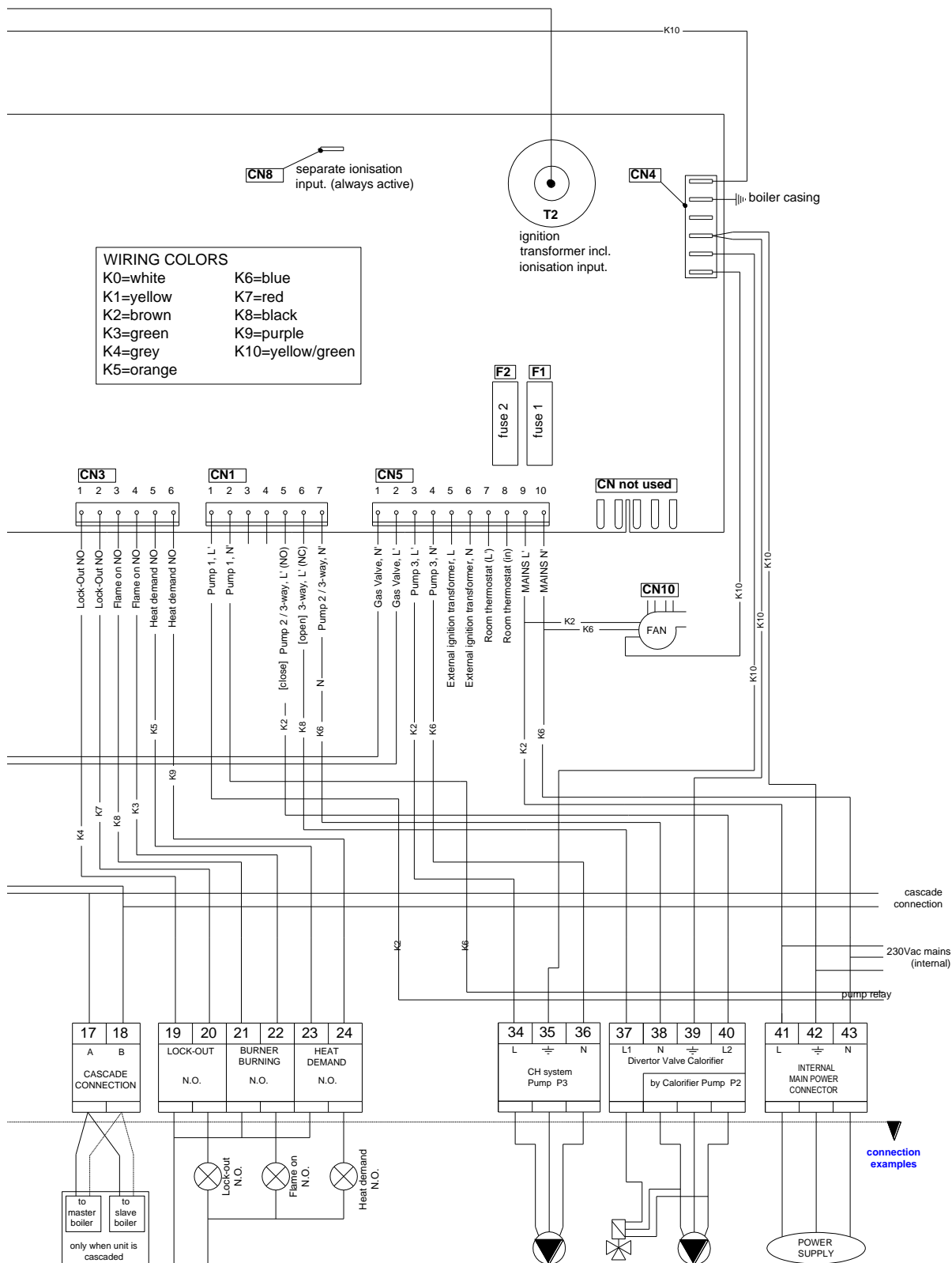

9.9 Electrical circuit diagram Bottom burner (PCB B, right)

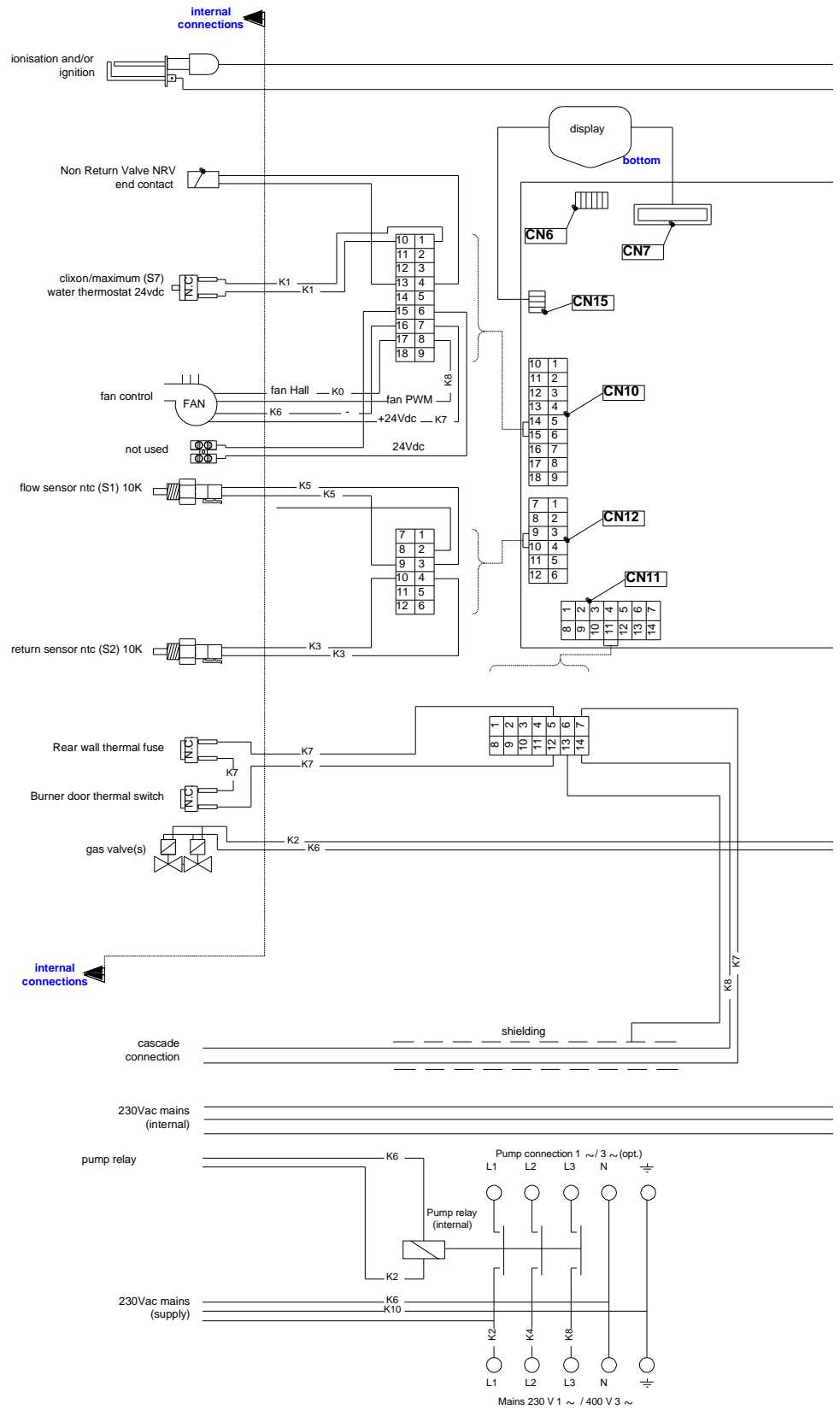

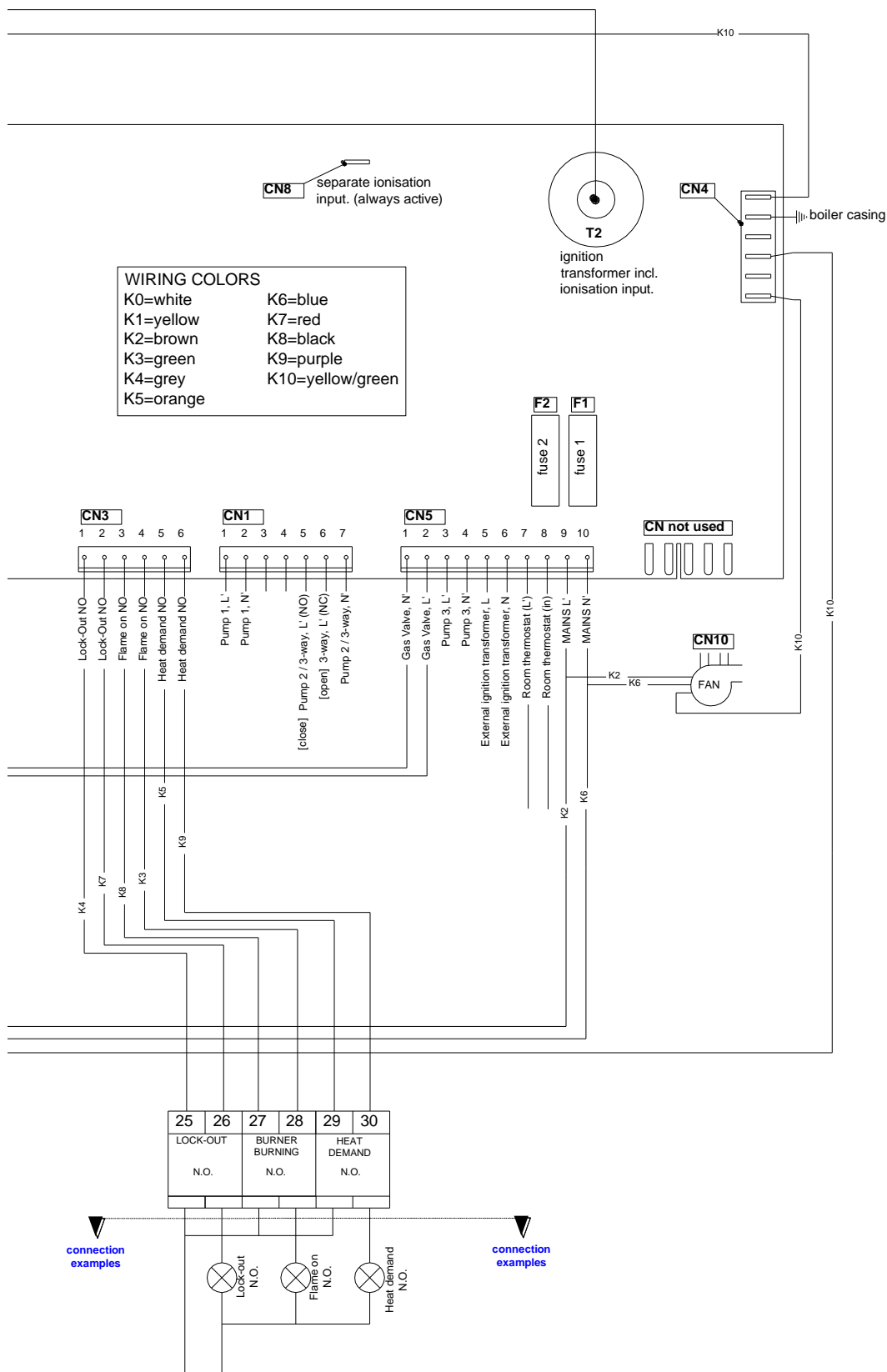









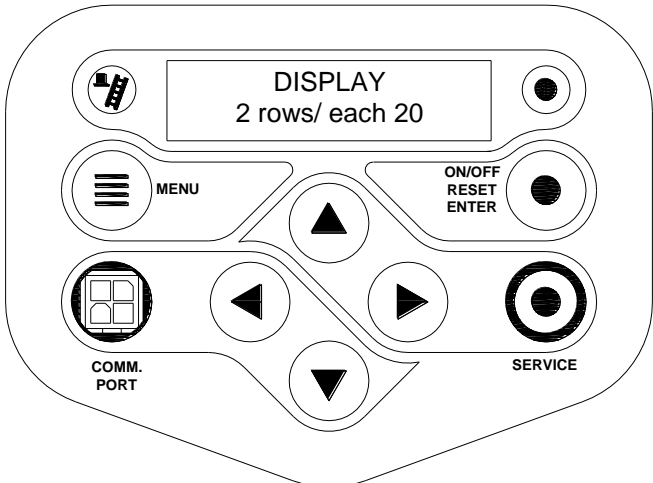

10 USER INTERFACE

10.1 Control panel / display unit

There are two control panels that have been placed on top of each other. The top panel controls the burner at the top of the heat exchanger and is called "master". This panel controls the complete boiler. Only when a lock out / error of the top burner has occurred, the boiler can be controlled by the bottom panel of the boiler (automatically).

CONTROL PANEL



	Press and hold for three seconds for stand-by/progr. mode Press and hold for six seconds to switch boiler on/off.
	Connector for connecting computer cable.
MENU 	Button is pushed to open MENU.
 	Buttons to toggle through measured temperatures. Also used for navigating through the menus and for changing values.
 	
	Button to activate service function (hold for three seconds).
	Schornsteinfeger function (only for Germany).
	Light: lights when controller detects good flame signal. Lights when burner is burning.

10.2 Menu structure

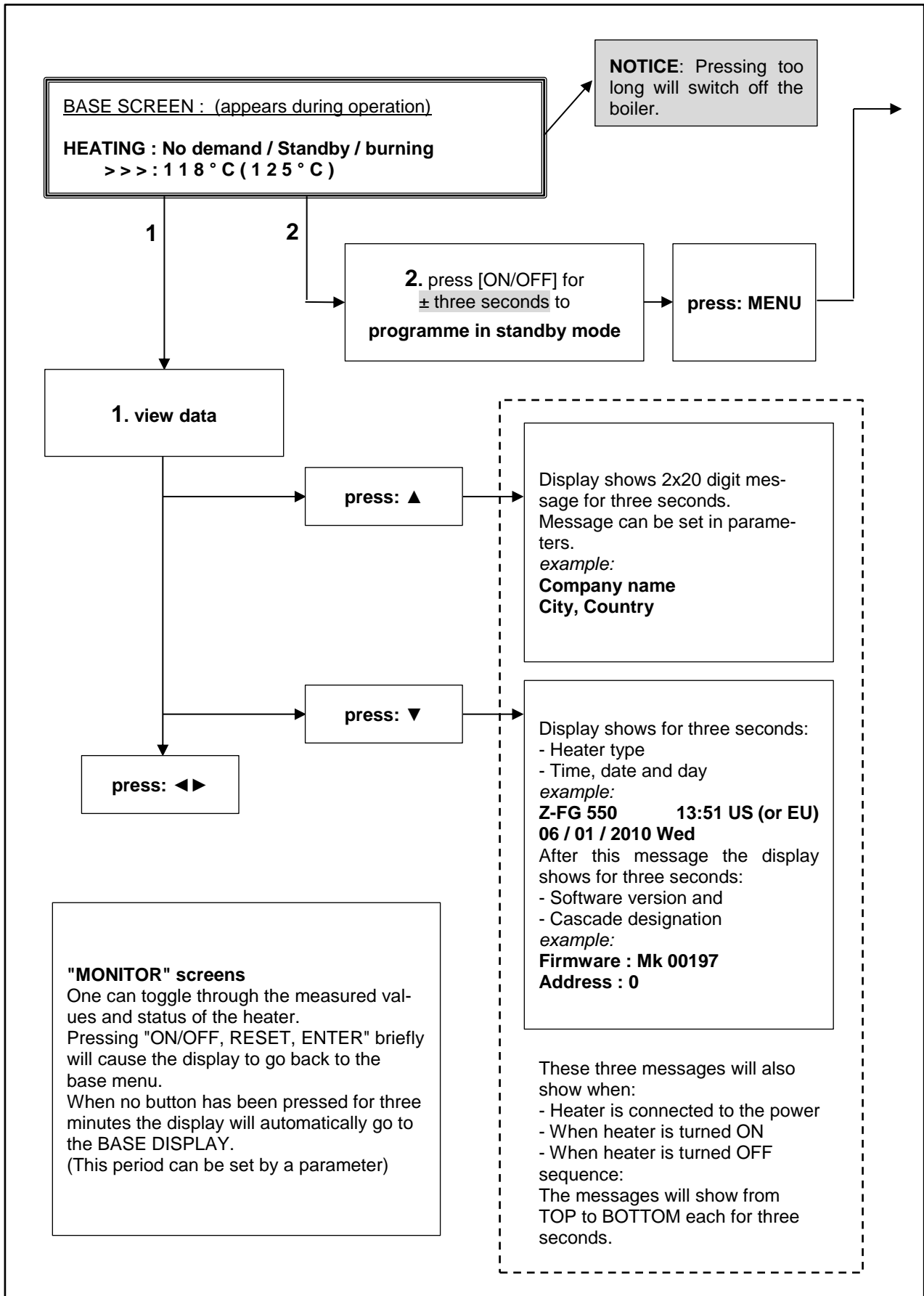

HOW TO CONFIRM CHANGES

When changes have been made in one of the nine menus below, the user presses ENTER to confirm these changes.

To prevent making unintentional changes, the following happens when changes are made:

Step 1: The user presses [ENTER] to confirm the change made or [MENU] to exit the menu without changes. HINT: First programme all changes planned, then only after that, press [ENTER]

Step 2: The display asks the user to be sure to make these changes. The user can cancel or confirm by using the left and right arrows.

CANCEL = ◀ CONFIRM = ▶

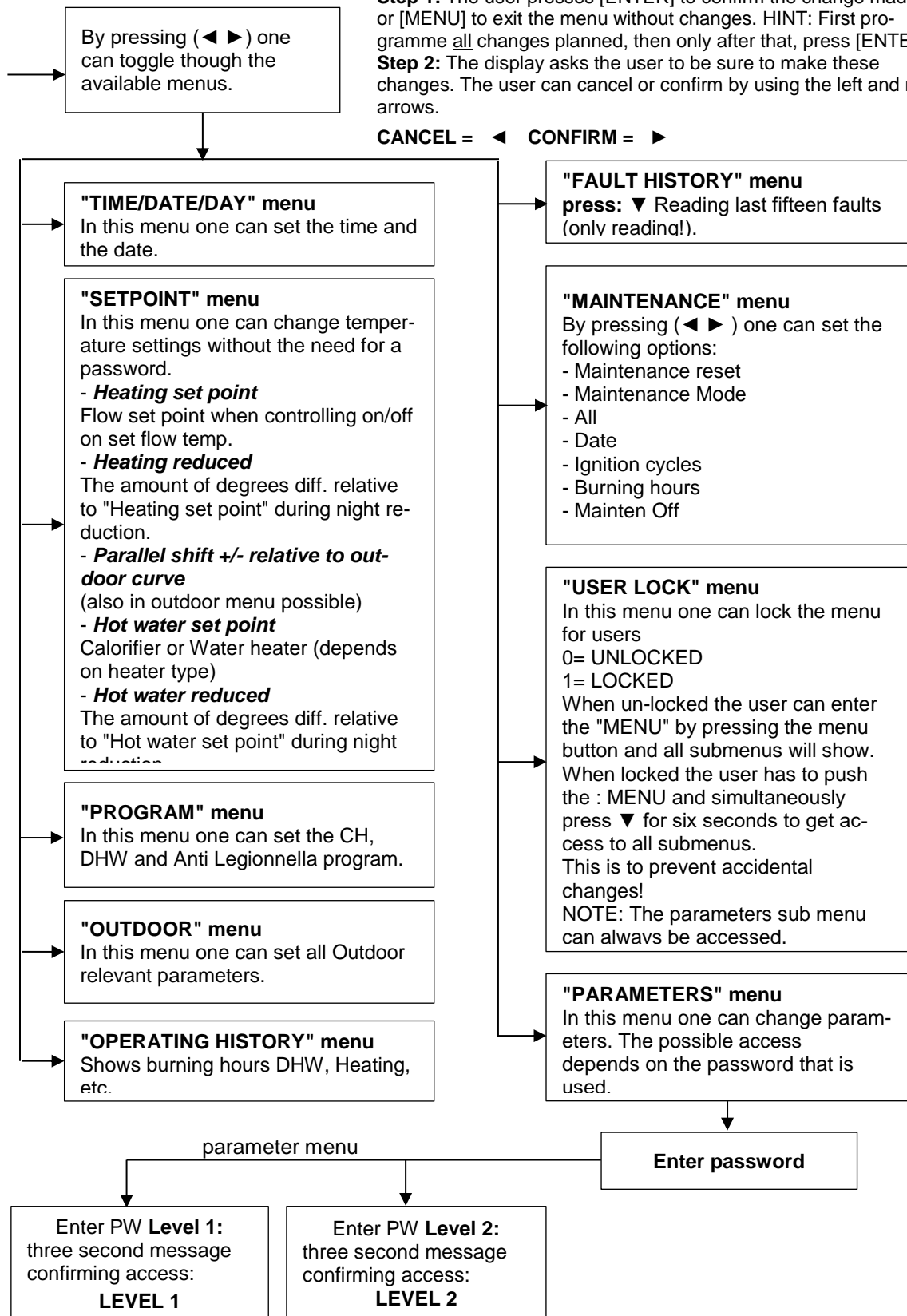

10.3 Display during operation

During normal operation, the text in the display shows the status of the boiler. In the following graphs, the several displays during normal operation are explained.

Display at HEATING DEMAND

Heat demand type:				Actual status:															
H	E	A	T	I	N	G	:	S	T	A	N	D	-	B	Y				
>	>	>	:	1	2	3	.	4	°	C	(1	2	3	.	4	°	C)
cascade communication indicator				temp. set point				control.sensor showing the measured temperature. <u>Can be turned off by P5 BJ</u>											

Display at HOT WATER DEMAND

Heat demand type:				Actual status:															
H	O	T	W	A	T	R	:	S	T	A	N	D	-	B	Y				
>	>	>	:	1	2	3	.	4	°	C	(1	2	3	.	4	°	C)
cascade communication indicator				temp. set point Thermostat > coil flow temp. Sensor > water temp.				control sensor showing the measured temp. <u>Can be turned off by P5 BJ</u>											

Explanation "Actual status" screen

Actual status:	
B o i l e r o f f	When boiler is switched off (only text in the display during this status).
N o d e m a n d	No heat demand signal coming from the room thermostat and calorifier sensor (open).
S t a n d - b y	Room thermostat & calorifier sensor/thermostat detect heat demand but set point is reached.
P r e - p u r g e	The fan is purging before a burner start attempt.
P r e - i g n i t i o n	Ignition starts before opening of the gas valve.
I g n i t i o n	The ignition is igniting.
P o s t - p u r g e	The fan is purging after burner is switched off.
B u r n i n g 1 0 0 %	When the burner is firing, also the actual rpm% is shown.

Explanation "Cascade communication indicator"

NO CASCADE COMMUNICATION

> > > no.1
Always showing the fixed ">>>"

CORRECT CASCADE COMMUNICATION

> > no.1
> > no.2
Showing alternating no.1 & no.2 with 1 second interval.

10.4 Monitor screens

During normal operation and stand-by, the “◀” and “▶” buttons can be used to show some boiler information, including measured temperatures, settings and data. In the following graphs is explained which values can be shown in the display. When no button is activated for 2 minutes, the display will return to its status display.

Pressing [◀] or [▶] while being at the "operating screen" toggles through the screens below. When pressing [ON/OFF, RESET, ENTER] or [MENU] at any time the display returns to the base menu.

SCREEN: 1

T 1	F l o w	1 2 3 , 9 ° C	Measured value by the internal flow sensor.
T 2	R e t u r n	1 2 3 , 9 ° C	Measured value by the internal return sensor.
		O p e n	Shown when controller doesn't detect this sensor.
		S h o r t e d	Shown when sensor wires or sensor itself is shorted.

SCREEN: 2

T 3	E x t e r n a l	1 2 3 , 9 ° C	Measured value by the external sensor, or else the average of both the S1 values.
T 4	C a l o r i f i	1 2 3 , 9 ° C	Measured value by the calorifier sensor.
		O p e n	Shown when controller doesn't detect this sensor.
		S h o r t e d	Shown when sensor wires or sensor itself is shorted.

SCREEN: 3

T 5	O u t d o o r	1 2 3 , 9 ° C	Measured value by the outdoor sensor.
T 6	F l u e	1 2 3 , 9 ° C	Measured value by the flue gas sensor.
		O p e n	Shown when controller doesn't detect this sensor.
		S h o r t e d	Shown when sensor wires or sensor itself is shorted.

SCREEN: 4

d T F l o w R e t u r n	1 2 3 , 9 ° C	Temp. difference between internal flow & return sensor.
d T F l u e R e t u r n	1 2 3 , 9 ° C	Temp. difference between flue gas & internal return sensor.

SCREEN: 5

d T E x t R e t u r n	1 2 3 , 9 ° C	Temp. difference between external & internal return (ΔT LLH).
S i g n a l	P o w e r	External supplied 0-10 Volt dc signal.
	S e t p o i	"Power" = power input control or "Setpoi" = set point control.

SCREEN: 6

F a n s p e e d	9 9 9 9 r p m	Actual fan speed in rpm.
F a n s p e e d	1 0 0 %	Actual fan speed % of maximum allowable fan speed.

Fan maximum RPM: The maximum actual rpm may be lower than the maximum rpm set point. The fan may not be able to reach the maximum rpm set point, because of the unit's resistance, which is still correct according to the design of that specific unit.

SCREEN: 7

F l a m e s i g n a l	1 0 0 μ A	Flame signal given in μA.
W a t e r P r e s s u r e	1 , 0 b a r	Shows water pressure when sensor is connected.

SCREEN: 8

P u m p 1 H e a t e r	O f f	Pump 1 (HEATER PUMP) On or Off.
P u m p 1 S i g n a l	1 0 0 %	Modulating signal Pump 1 in (%).

SCREEN: 9

P u m p 2 C a l o r i f i	O f f	Shows when the calorifier pump is "ON" or "OF".
3 - w a y V a l v e H e a t i n g		Signal to the 3-way valve: "HEATING" or "HOTWATER".

SCREEN: 10

P u m p 3 S y s t e m	O f f	Shows when the system pump is "ON" or "OF".
h h : m m D D / M M / Y Y Y Y D a y		hh=hour; mm=minutes; DD=day; MM=month; YYYY=yr; Day of the week

SCREEN: 11

C	a	s	c		D	e	s	i	g	n					0						0 = MASTER, 1 11 = SLAVES	
C	a	s	i	n	f			0	1	2	3	4	5	6	7	8	9	A	B			Displays number, priority and state of cascade boilers.

DESCRIPTION "CASCINFO" Screen 11

Shows the number of boilers connected with the Cascade. The Master/Lead boiler is designated as 0. Slave/Lag boilers will be designated 1, 2, 3, 4, 5, 6, 7, 8, 9, A, B. When a "-" is used instead of a number, then that boiler is either not connected, or in a lockout mode and not available for the Cascade. When an "x" is used instead of a number, then that boiler is connected, but in lockout mode.

When a "d" is used instead of a number, then that boiler is handling a DHW demand.

When the number is flashing, then that boiler is providing heat to the cascade. When the leading boiler is changed according to the set priority change time, then that boiler's address will be shown first in the row of numbers.

Example 1: "3 4 5 - - - - - 0 1 2"

There are six boilers present and nr. 3 has priority.

Example 2: "3 4 x - - - - - d 1 2"

There are six boilers present and nr. 3 has priority. Boiler 0 is heating up an indirect DHW tank. Boiler 5 is present, but in a lock-out.

SCREEN: 12

C	a	s	c		P	o	w	e	r		9	9	9	%		9	9	9	%	% heat demand of total (cascade) power available (%).	
D	u	a	i		B	u	r	n	e	r	:				N	o					Heat exchanger equipped with two burners: "Yes" or "No".

SCREEN: 13

M	a	x		T	h	e	r	m						O	p	e	n			Status of the maximum thermostat: "Open" or "Closed".
G	e	n		B	l	o	c	k						C	l	o	s	e	d	Status of the general blocking contact: "Open" or "Closed".

SCREEN: 14

S	i	p	h	o	n		p	r	e	s	s				C	l	o	s	e	d	Status of the siphon pressure switch: "Open" or "Closed".
N	R	V		C	o	n	t	a	c	t					O	p	e	n			Status of the non-return valve contact: "Open" or "Closed".

10.5 Service function

The following graphs describe how to use the service function.

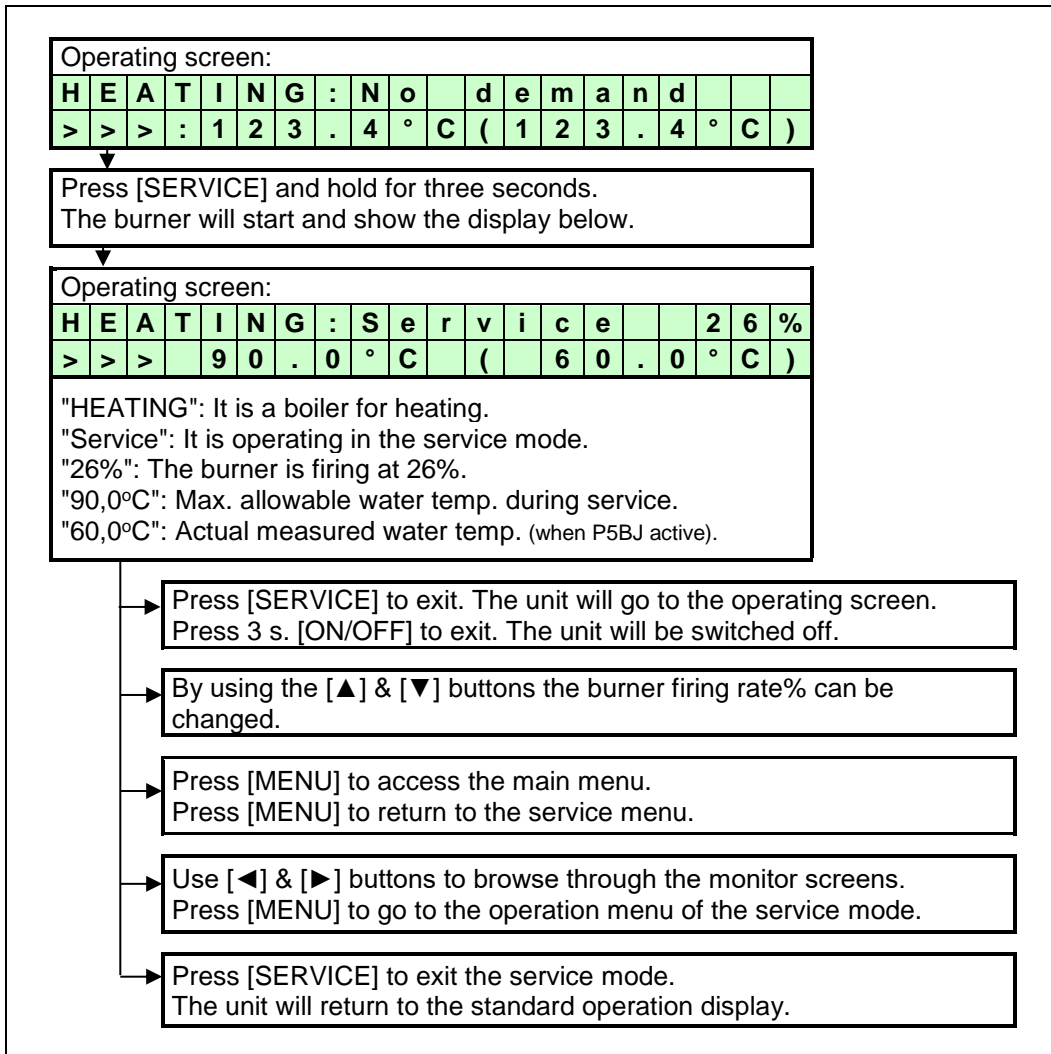

10.6 Schornsteinfeger function

The following graphs describe how to use the Schornsteinfeger function.

NOTICE: This function is required for Germany and can be activated by parameter (P5 BK). The standard factory setting for this function is "OFF".

The purpose of this function is to have an easy interface for the "Schornsteinfegers" in Germany, to be able to do their required testing on the boiler. This is a simplified function similar to the normal service function of the boiler.



When the "Schornsteinfeger" button is pressed for three seconds: the heater will fire at **minimum firing rate (%)**

In this state, the display shows:

F	l	u	e	s	e	r	v	i	c	e	m	o	d	e		
P	o	w	e	r	:	M	i	n	i	m	u	m				

When the button is pressed (briefly) again: the heater will fire at **50% firing rate**

In this state, the display shows:

F	l	u	e	s	e	r	v	i	c	e	m	o	d	e		
P	o	w	e	r	:	5	0	%								

When the button is pressed (briefly) again: the heater will fire at **maximum firing rate (%)**

In this state the display shows:

F	l	u	e	s	e	r	v	i	c	e	m	o	d	e		
P	o	w	e	r	:	M	a	x	i	m	u	m				

When the button is pressed briefly again: the heater will return to the normal operation mode. The "Schornsteinfeger" function is switched off.

NOTES:

When the heater is burning during Schornsteinfeger function (when top display line shows "Flue service mode") and no button is pressed for 12 minutes, the boiler will return automatically to the normal operation mode. The "Schornsteinfeger" function will be switched off.

The "Schornsteinfeger function" can be activated for the user by programming a parameter (P5 BK)

All regular temperature safety controls remain active and the boiler/water heater pump and the system pump are running.

10.7 Programming in standby mode

Standby

Use the standby mode for modifying boiler settings without interaction with the boiler control. Changes are effected at leaving standby mode.

Properties of standby mode:

- Keys are active and the menu is accessible.
- Burners do NOT respond to an external heat demand.
- All control functions are ON: pumps, fans and cascade are operational, recirculation and frost protection are both active.

How to program the boiler:

- Disconnect or shut down the room thermostat and/or other external controllers from the boiler. The CH pump and fan will stop after a short time.
- Switch the boiler in standby mode by pressing [ON/OFF] for three seconds.
- The next display screen should appear:

Display message	H	E	A	T	I	N	G	:	b	o	i	l	e	r	o	f	f			
	>	>	>	:	1	2	3	.	4	°	C	(1	2	3	.	4	°	C)

- Program the boiler at the control panel (see the following sections).
- Terminate programming mode by pressing [MENU], or [ENTER] and NO ◀ or YES ▶.
- Reactivate the boiler by pressing [ON/OFF] for three seconds again.

10.8 Setting the time & date

The following graphs describe how to program the time and date of the unit.

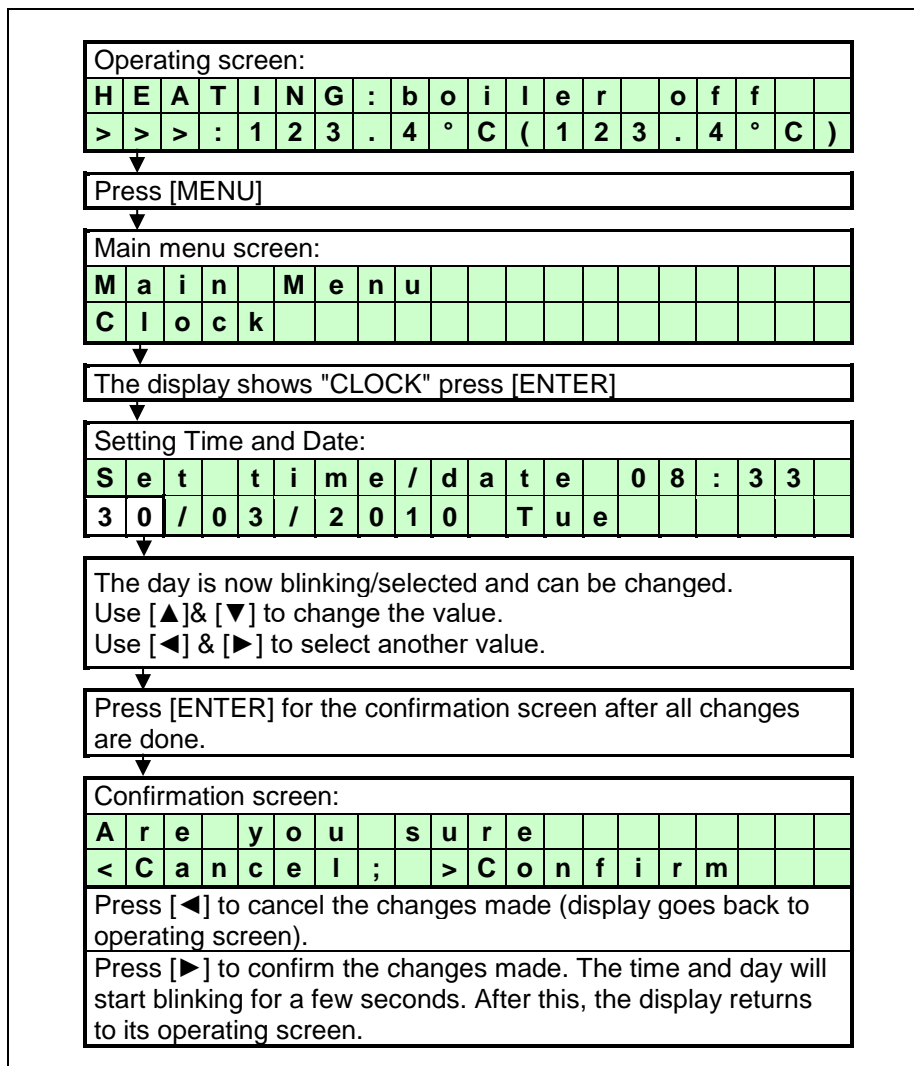

10.9 Set points

The following graphs describe how to program the heating and hot water set points.

NOTICE: The hot water set points are only displayed, when the boiler is programmed as an indirect hot water boiler or direct hot water boiler. See parameter P4 AA for the exact boiler configuration.

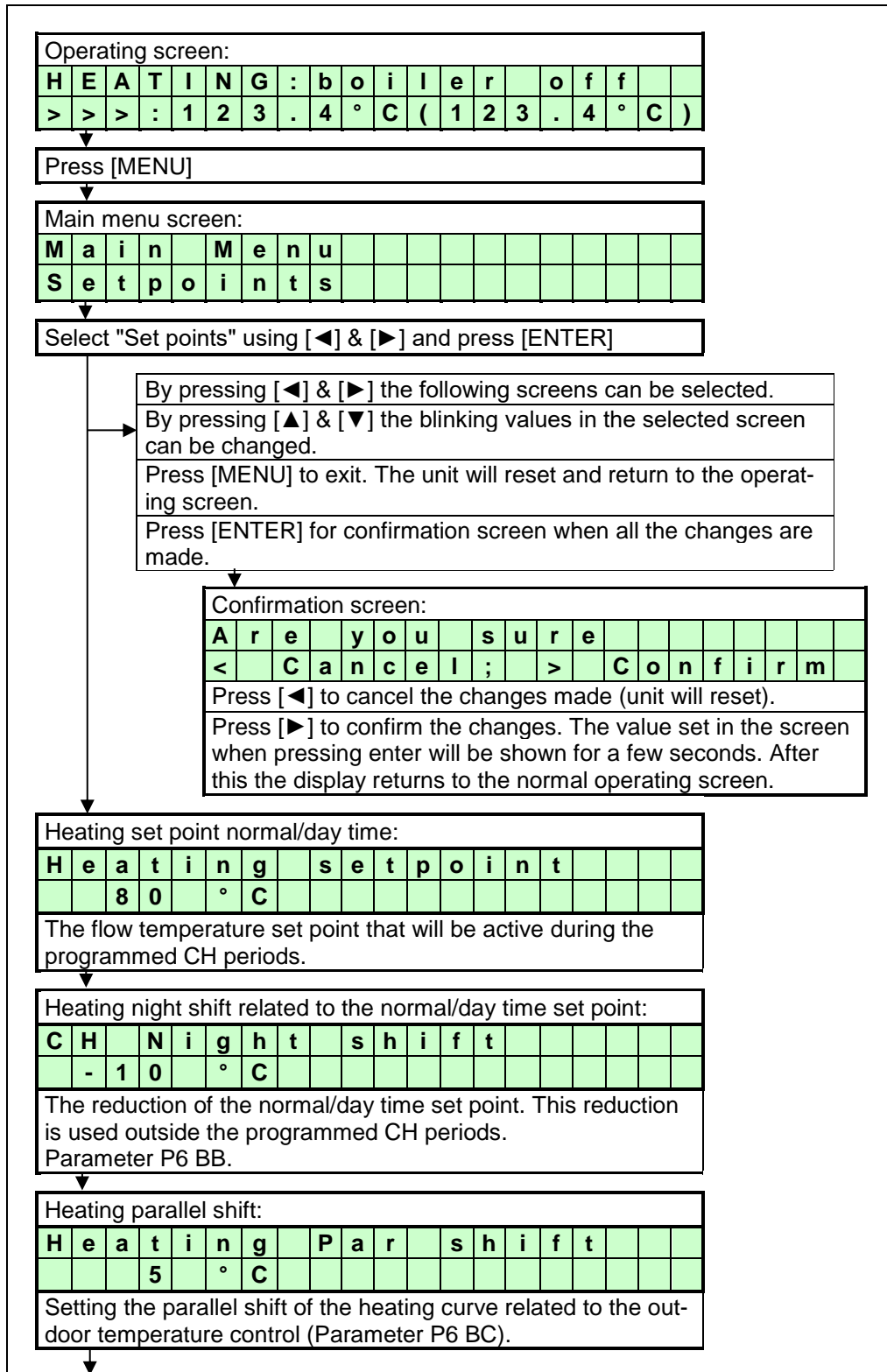

↓

DHW set point normal/day time: (parameter P4 AA = 1/2)

D	H	W		s	e	t	p	o	i	n	t								
		6	0					°	C										

This is the water temperature set point that is active during the programmed DHW periods (parameter P4 AA = 1/2).

↓

DHW set point reduction: (Parameter P4 AA = 1/2)

D	H	W		R	e	d	u	c	e										
		1	0					°	C										

The reduction of the DHW set point related to normal/day time set point. This reduction is used outside the programmed DHW periods (parameter P4 AA = 1/2).

NOTICE:
 The max actual DHW temperature will never exceed the value set at "Heating Setpoint" regardless the set DHW setpoint. If higher DHW setpoints are needed the Heating Setpoint has to be set higher also.

10.10 Setting the timer programs

Three different programs can be set with the boiler, these are:

- CH program
- DHW program
- Anti-Legionnaires' disease (pasteurisation) program

HEATING PROGRAM

Three programmed periods each day can be set (period 1, period 2 and period 3). During these periods, the unit will use the normal CH and DHW set points. Outside the programmed period(s) the unit will use the reduced temperature as set point. When there is no time programmed for a period, it will not be used. (Example no time programmed in period 3 on Monday > "Mon 3 --:-- --:--").

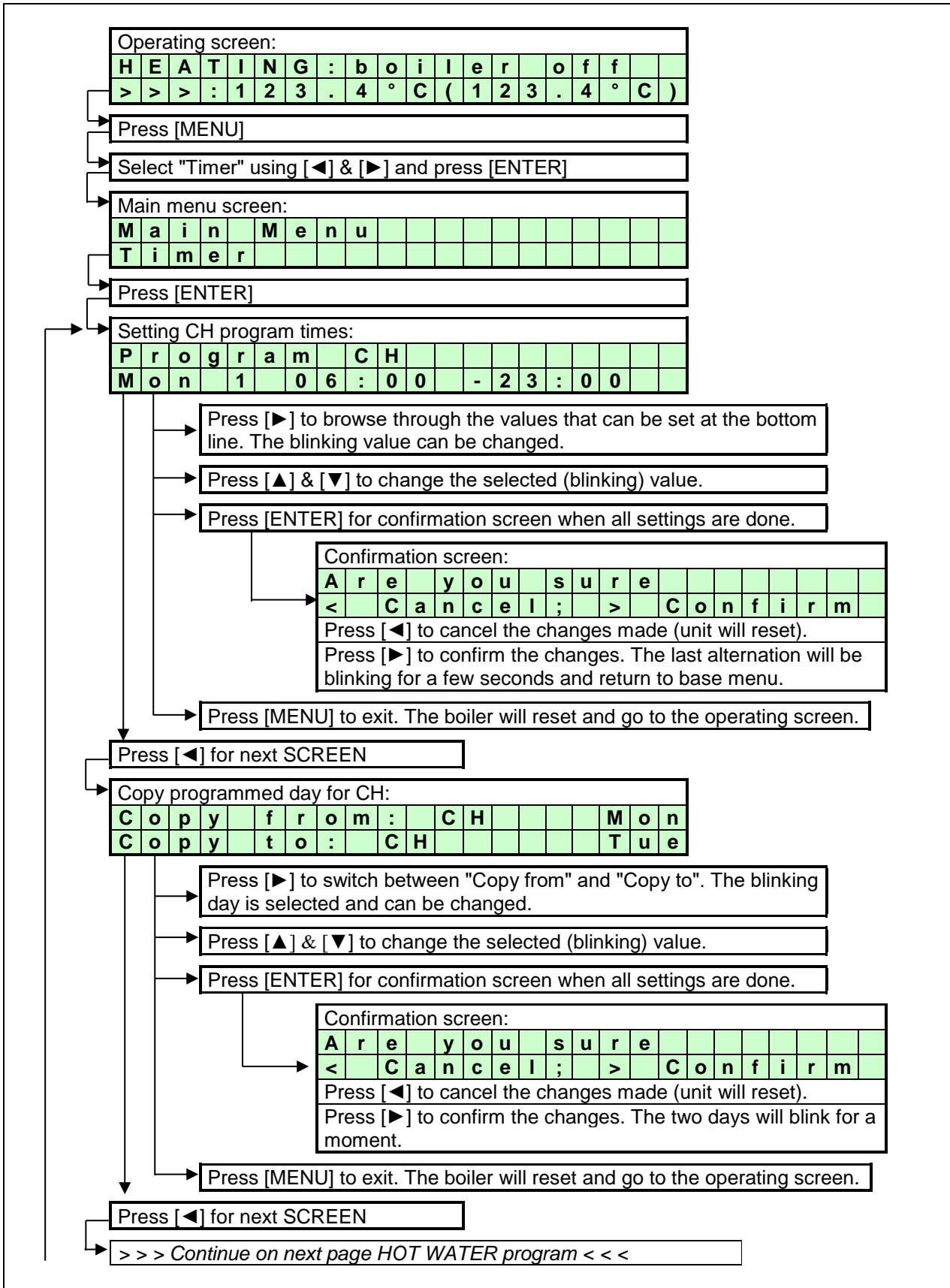

HOT WATER PROGRAM

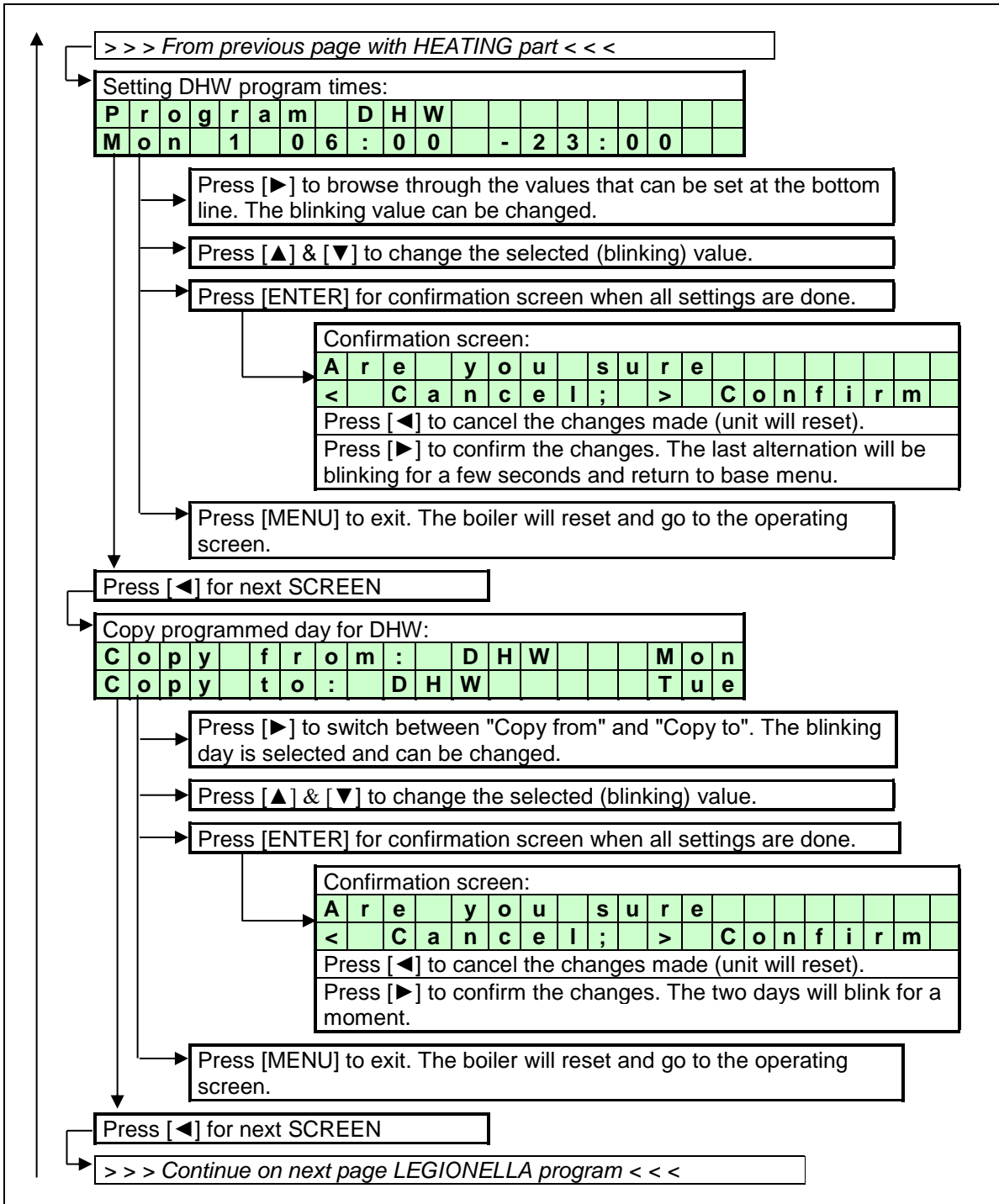

ANTI LEGIONNAIRES' DISEASE PROGRAM

The anti-Legionnaires' disease (pasteurisation) program of the boiler can only be used when the boiler is set as an "indirect" boiler configuration or a "direct" hot water boiler configuration. Only these configurations can activate the day and time program of the anti-Legionnaires' disease function. See the following graphs. The standard factory setting for this function is "OFF".

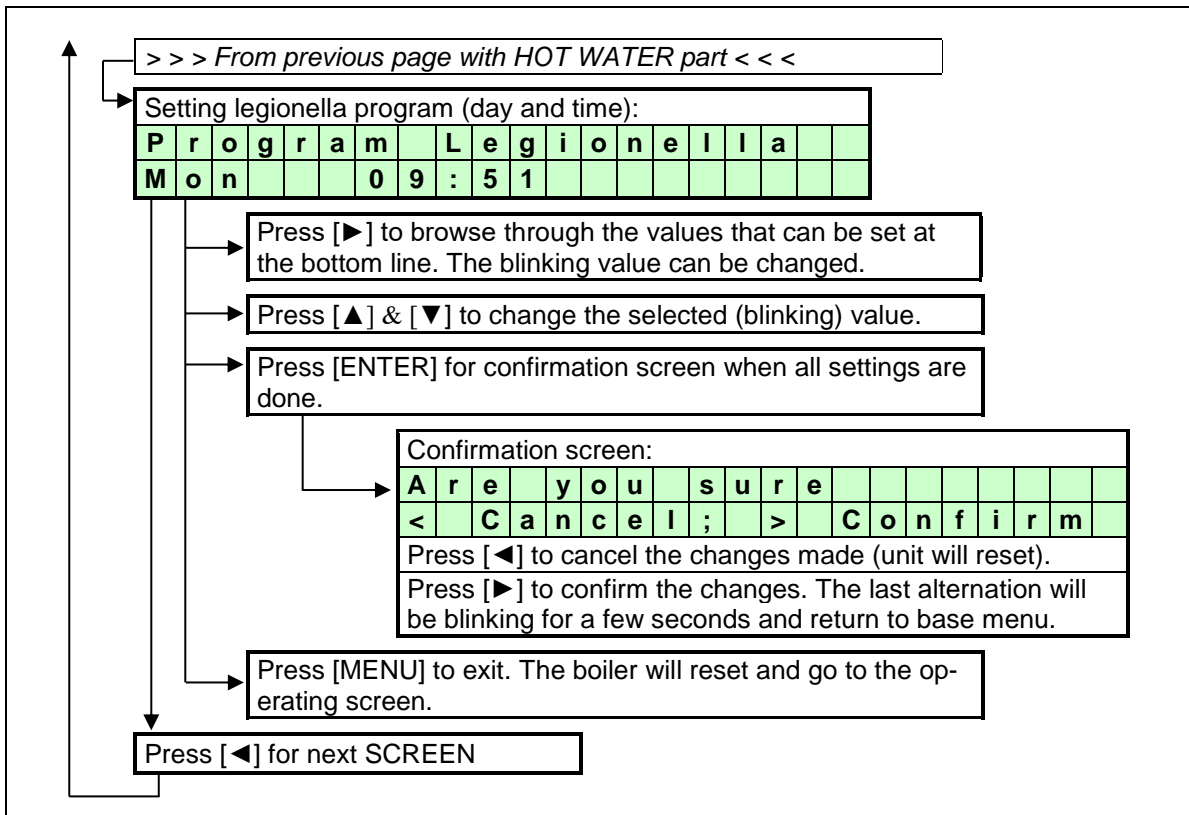

10.11 Setting the outdoor specifications

10.11.1 PARAMETERS FOR SETTING THE OUTDOOR GRAPH

When using this function, the flow temperature is calculated based on the measured outdoor temperature. The relation between the outdoor temperature and the flow temperature can be programmed with the following parameters. This setting creates the so called "heating curve" (outdoor graph).

The boiler will recognize an outdoor sensor when it is connected. When the sensor is detected the boiler controller will control the flow temperature based on the heating curve that is programmed.

P5 AA OutsidPres. (1=On 0=Off)

Outside sensor present.

Setting this parameter to "On" a fault message will be displayed in case of an interrupted connection to the outdoor sensor or if the measured outdoor temperature exceeds 60°C (defective sensor).

0 => No fault message at interrupted outdoor sensor connection. Boiler keeps burning using the value of the external or internal flow sensor instead of the outdoor sensor.

1 => Interrupted sensor wiring causes a fault message to occur at the display Boiler keeps burning using the value of the external or internal flow sensor instead of the outdoor sensor.

10.11.3 OUTDOOR GRAPH - ADDITIONAL SETTINGS

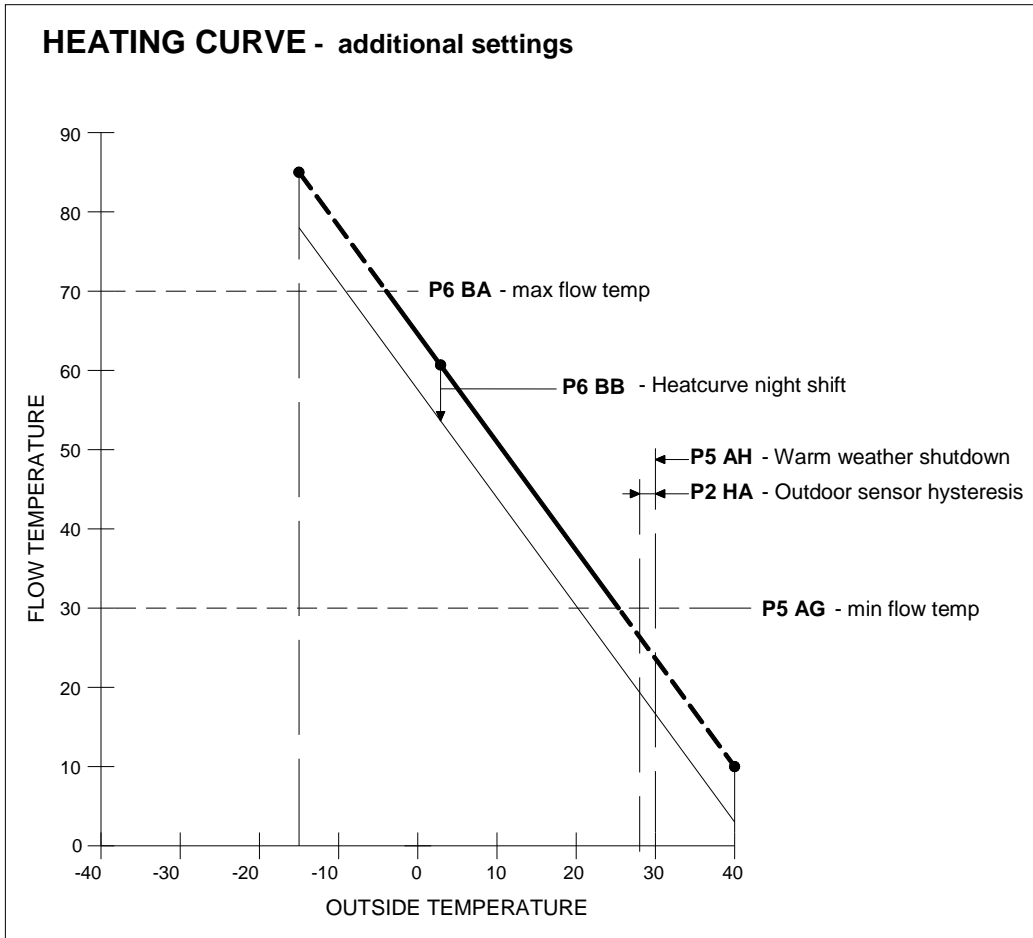

Curve and values only for illustration purposes, programmed parameter values can deviate!

P5 AG Heat curve minimum flow temperature °C
 The set point will never be lower than the flow temperature set in parameter P5 AG. The minimum temperature is limited, even if the calculated set temperature, according to the heating curve, would be lower.

P5 AH Summer outside temperature central heating °C
 If the outside temperature is higher than set in P5AH the heat demand for heating will be blocked.

P5AR Outdoor sensor 10K or 12K resistance (1 or 0)
 Depending to the used type of sensor this parameter can be set. Set to '0' when using a so called 12k NTC sensor (sensor resistance is 12 kohm at 25°C) Set to '1' when using a so called 10k NTC sensor (sensor resistance is 10 kohm at 25°C) Default the parameter = 0, so the used sensor is assumed to be 12 kΩ.

P2 HA Outdoor sensor hysteresis °C
 If the outdoor temperature reaches the temperature set in P5 AH (Warm weather shutdown) the unit won't start for heating. If the measured outdoor temperature drops P5 AH minus P2 HA the boiler can start up for heating again.

P6 BA CH User Setting °C
 The set point will never be higher than the flow temperature set in parameter P6BA. The maximum temperature is limited, even if the calculated set temperature, according to the heating curve, would be higher.

P6 BB Heat curve night shift °C
 The temperature reduction during the night, relative to the setting determined by the heat curve

10.11.4 DISPLAY

The following graphs describe how to programme the outdoor graph settings.

Operating screen:
H E A T I N G : b o i l e r o f f
> > > : 1 2 3 . 4 ° C (1 2 3 . 4 ° C)

Press [MENU]

Select "Outdoor" using [◀] & [▶] and press [ENTER]

Main menu screen:
M a i n M e n u
O u t d o o r

- Press [◀] & [▶] to browse through the screens that are shown below.
- Press [▲] [▼] to change the blinking value in the selected screen.
- Press [MENU] to exit. The unit will reset and go to the operating screen.
- Press [ENTER] for confirmation screen after all changes are made.

Confirmation screen:
A r e y o u s u r e
< C a n c e l ; > C o n f i r m

- Press [◀] to cancel the changes made (unit will reset).
- Press [▶] to confirm the changes made. The time and day will start blinking for a few seconds. After this, the display returns to its operating screen.

01	OutsidPres	P5 AA
02	HCminOUTmp - 1 5 ° C	P5 AC
03	HCminFITmp 8 5 ° C	P5 AD
04	HCmaxOUTmp 2 0 ° C	P5 AE
05	HCmaxFITmp 2 0 ° C	P5 AF
06	HCminFILim 2 0 ° C	P5 AG
07	SumShDwnOu 3 0 ° C	P5 AH
08	HCmaxFILim 8 5 ° C	P6 BA
09	HCnghtshft - 1 0 ° C	P6 BB
0A	HCparashft 5 ° C	P6 BC
0B	OutS12k10k 0	P5 AR

10.12 Checking the operating history

The following graphs describe how to check the operating history of the boiler.

Operating screen:																								
H	E	A	T	I	N	G	:	b	o	i	l	e	r	o	f	f								
>	>	>	:	1	2	3	.	4	°	C	(1	2	3	.	4	°	C)						
Press [MENU]																								
Select "Operate" using [◀] & [▶] and press [ENTER]																								
Main menu screen:																								
M	a	i	n		M	e	n	u																
O	p	e	r	a	t	e																		
Press [◀] & [▶] to browse through the 5 screens.																								
Press [MENU] or [ENTER] to exit. The unit will return to the operating screen.																								
SCREEN: 1																								
O	p	e	r	a	t	i	n	g		h	i	s	t	o	r	y								
P	o	w	e	r	O	n				h	r	s			1	3	1	4	0	0				
Top line: Shows the operating history menu is activated.																								
Bottom line: Total hours the boiler is connected to power supply and switched on.																								
SCREEN: 2																								
h	r	s	C	h						T	o	t					1	0	0	0	0	0	0	0
h	r	s	D	h	w					T	o	t					1	0	0	0	0	0	0	0
Top line: Total burning hours for heating.																								
Bottom line: Total burning hours for domestic hot water.																								
SCREEN: 3																								
h	r	s	C	h						<	5	0	%				1	0	0	0	0	0	0	0
h	r	s	C	h						=	>	5	0	%			1	0	0	0	0	0	0	0
Top line: Burning hours for heating while the burner was firing less than 50%.																								
Bottom line: Burning hours for heating while the burner was firing equal or higher than 50%.																								
SCREEN: 4																								
h	r	s	D	h	w					<	5	0	%		:		1	0	0	0	0	0	0	0
h	r	s	D	h	w					=	>	5	0	%		:	1	0	0	0	0	0	0	0
Top line: Burning hours for hot water while the burner was firing less than 50%.																								
Bottom line: Burning hours for hot water while the burner was firing equal or higher than 50%.																								
SCREEN: 5																								
T	i	a	1	0	0	0	0	0	0	F	i	a					1	0	0	0	0	0	0	0
S	s	i	1	0	0	0	0	0	0	S	s	t					1	0	0	0	0	0	6	
Top line: Shows Total Ignition Attempts (Tia) & Failed Ignition Attempts (Fia)																								
Bottom line: Shows Soft Starts last (Ssi) & Soft Starts Total (Sst)																								

10.13 Checking the fault history

The following graphs describe how to check the fault history of the boiler.

Operating screen:																			
H	E	A	T	I	N	G	:	b	o	i	l	e	r	o	f	f			
>	>	>	:	1	2	3	.	4	°	C	(1	2	3	.	4	°	C)

Press [MENU]

Select "Faultist" using [◀] & [▶] and press [ENTER]																			
F	a	u	l	t	h	i	s	t							N	o	.	0	1
2	1	/	0	4	/	2	0	1	0	W	e	d		2	2	:	2	3	A

▲ blinking alternately ▼

S	i	p	h	o	n	S	w	i	t	c	h								
S	v	9	9	9	/	C	U	M	9	9	9	/	R	9	9	9	9	,	5

Press [◀] & [▶] to browse through the last 10 faults.
Press [MENU] or [ENTER] to exit. The unit will return to the operating screen.

The fault menu shows the last 10 faults. For each fault the display blinks between the two screens shown above. The top line of the top screen shows the fault number and the bottom line of the top screen shows the date, day and time the fault occurred. On the top line of the bottom screen the fault type is displayed. The bottom line shows the following:

SV: The total amount of this fault that has occurred after the last time that the service history was erased (after service was done).

CUM: The total amount of this fault. The total amount cannot be erased after service, this shows the fault history of the boiler (electronics) since the start of operation.

R: Shows the elapsed time in hrs between the moment the fault occurred and the moment it was reset.

10.14 Setting the maintenance specifications

MAINTENANCE SETTINGS

The unit can be programmed in such a way that an automatic maintenance message is displayed. Three options can be selected. A maintenance message appears after:

- * A programmed date is reached.
- * An amount of burning hours is reached.
- * An amount of ignition cycles is reached.

One single option can be activated or all three options.

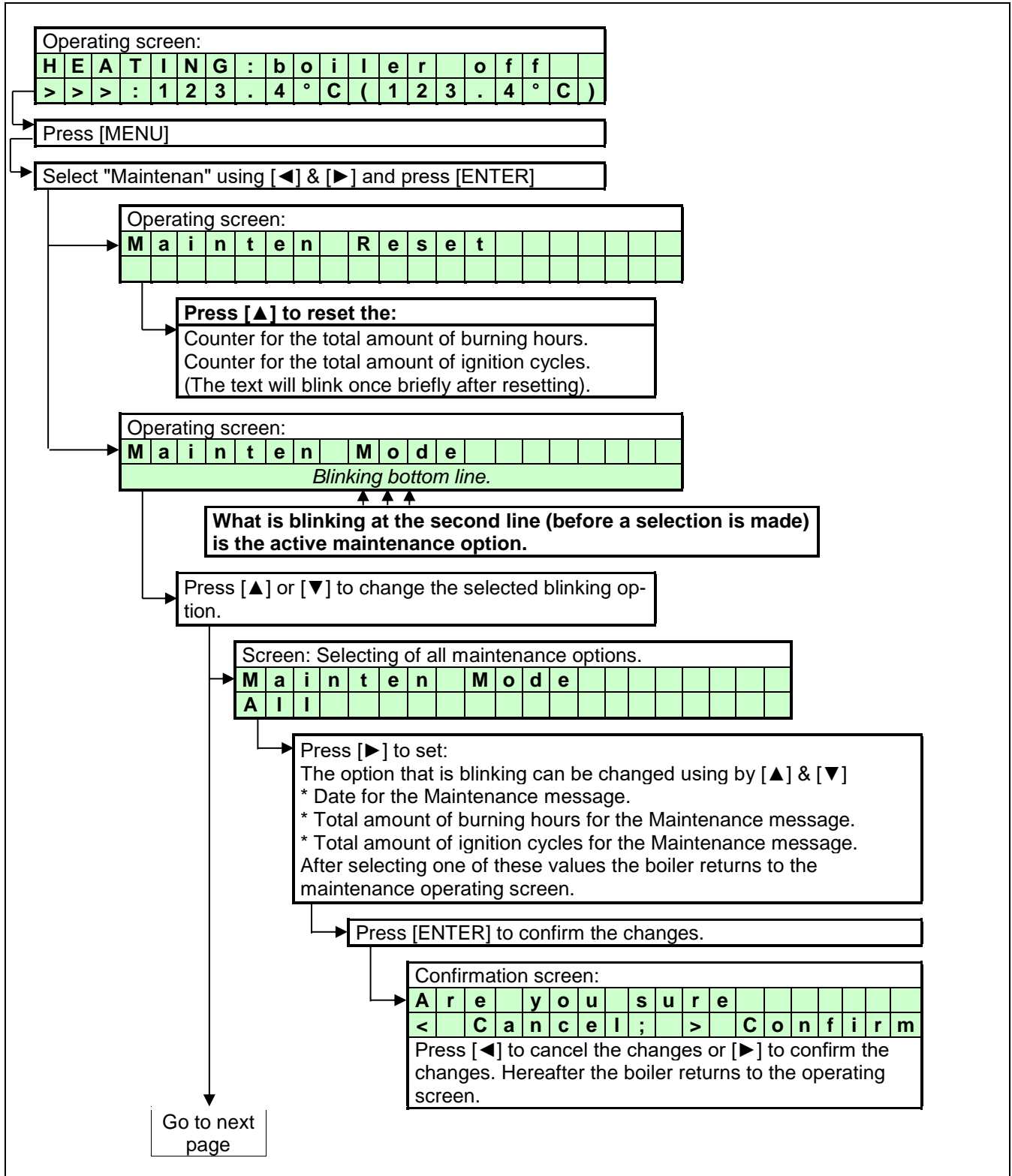

From previous page

Screen: Selecting message at certain date.
M a i n t e n M o d e
D a t e

Press [▶] to set:
The date for the maintenance message.

Press [◀] to:
Return to maintenance mode selection.

Press [▶] to browse through the values that can be set
at the bottom line.
The blinking value can be changed with [▲] & [▼]

Press [ENTER] to confirm the changes.

Confirmation screen:
A r e y o u s u r e
< C a n c e l ; > C o n f i r m
Press [◀] to cancel the changes or [▶] to confirm the
changes. Hereafter the boiler returns to the operating
screen.

Screen: Message after total amount of ignition cycles.
M a i n t e n M o d e
I g n i t i o n c y c l e s

Press [▶] to set:
The total amount of ignition cycles for the Maintenance message.

Press [◀] to:
Return to maintenance mode selection.

The blinking value can be changed with [▲] & [▼]

Press [ENTER] to confirm the changes.

Confirmation screen:
A r e y o u s u r e
< C a n c e l ; > C o n f i r m
Press [◀] to cancel the changes or [▶] to confirm the
changes. Hereafter the boiler returns to the operating
screen.

Go to
next page

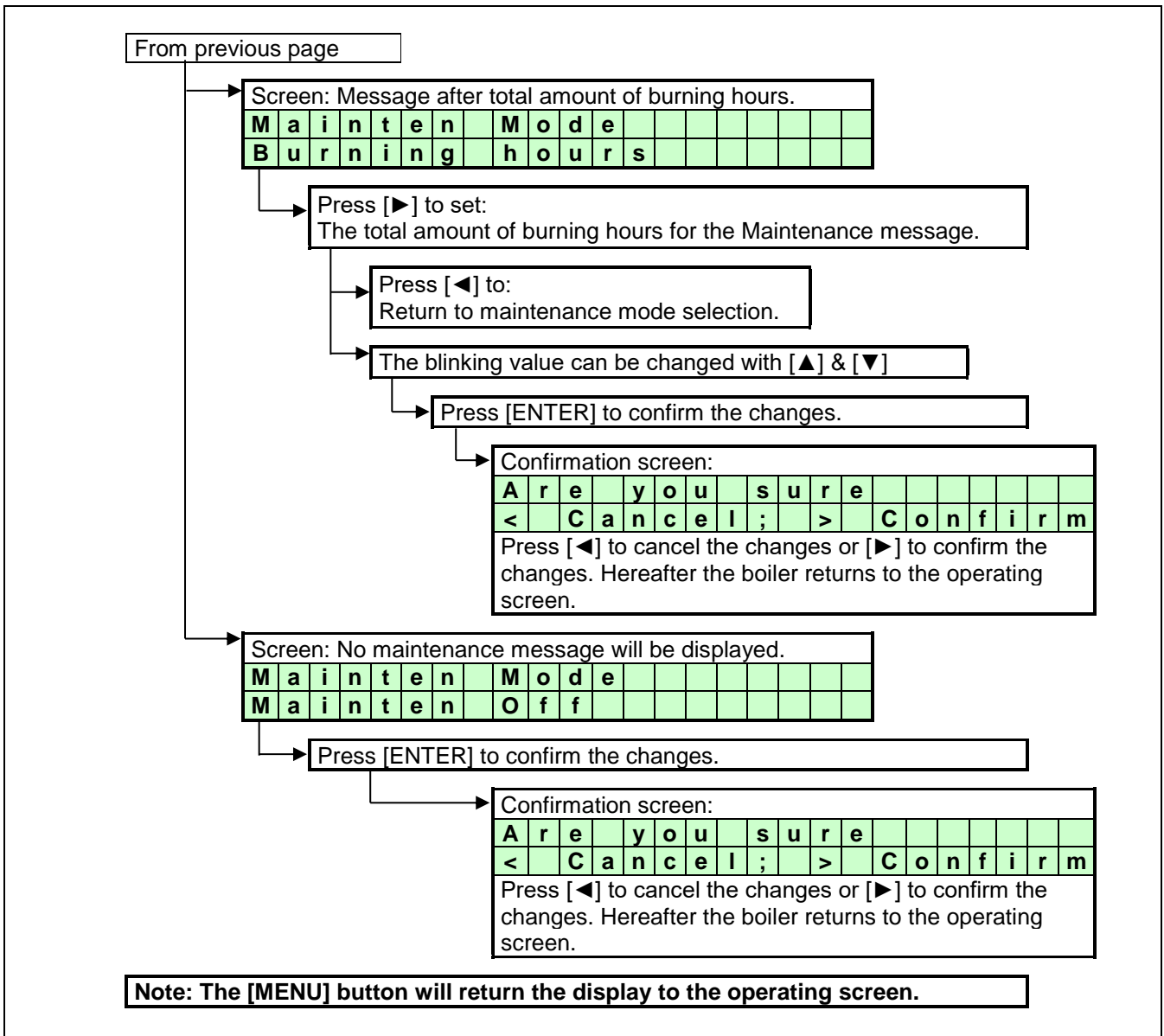

BE AWARE :

This function is standard turned OFF. We offer this programmable function to the installer to use as a reminder. Because it concerns a free programmable function the use of it cannot be used as an argument in warranty cases.

Our units must be maintained every twelve months whatever the settings/working of this function.

It is and remains the responsibly of the end user to have the unit maintained every twelve months.

10.15 Setting the user lock

The following graphs describe how to activate the user lock of the display. The standard factory setting for this function is "OFF".

<p>The "USER LOCK" menu. In this menu the boiler can be locked for (end-)users. 0 = UNLOCKED 1 = LOCKED</p>																																								
<p>When the boiler is unlocked, the user can enter the MENU by pressing the menu button and all screens will show up.</p>																																								
<p>When the boiler is locked, the user has to push the: [MENU] button together with the [▼] button for 5 s. to access all menu screens.</p>																																								
<p>This function is to prevent accidental changes.</p>																																								
<p>NOTICE: The PARAMETER screen always accessible.</p>																																								
<p>Operating screen:</p> <table border="1"> <tr> <td>H</td><td>E</td><td>A</td><td>T</td><td>I</td><td>N</td><td>G</td><td>:</td><td>b</td><td>o</td><td>i</td><td>l</td><td>e</td><td>r</td><td>o</td><td>f</td><td>f</td><td></td><td></td> </tr> <tr> <td>></td><td>></td><td>></td><td>:</td><td>1</td><td>2</td><td>3</td><td>.</td><td>4</td><td>°</td><td>C</td><td>(</td><td>1</td><td>2</td><td>3</td><td>.</td><td>4</td><td>°</td><td>C</td><td>)</td> </tr> </table>	H	E	A	T	I	N	G	:	b	o	i	l	e	r	o	f	f			>	>	>	:	1	2	3	.	4	°	C	(1	2	3	.	4	°	C)	
H	E	A	T	I	N	G	:	b	o	i	l	e	r	o	f	f																								
>	>	>	:	1	2	3	.	4	°	C	(1	2	3	.	4	°	C)																					
<p>Press [MENU]</p>																																								
<p>Select "User lock" using [◀] & [▶] and press [ENTER]</p>																																								
<p>User lock screen:</p> <table border="1"> <tr> <td>S</td><td>e</td><td>t</td><td></td><td>U</td><td>s</td><td>e</td><td>r</td><td>l</td><td>o</td><td>c</td><td>k</td><td>=</td><td>0</td><td></td><td></td><td></td><td></td><td></td><td></td> </tr> <tr> <td></td><td></td><td></td><td></td><td>0</td><td></td><td></td><td></td><td></td><td></td><td></td><td></td><td></td><td></td><td></td><td></td><td></td><td></td><td></td><td></td> </tr> </table>	S	e	t		U	s	e	r	l	o	c	k	=	0											0															
S	e	t		U	s	e	r	l	o	c	k	=	0																											
				0																																				
<p>The "0" is now blinking/selected and can be changed. Use [▲] & [▼] to change the value. 0 = User lock function OFF 1 = User lock function ON</p>																																								
<p>Press [ENTER] for the confirmation screen after the selection has been made.</p>																																								
<p>Confirmation screen:</p> <table border="1"> <tr> <td>A</td><td>r</td><td>e</td><td></td><td>y</td><td>o</td><td>u</td><td></td><td>s</td><td>u</td><td>r</td><td>e</td><td></td><td></td><td></td><td></td><td></td><td></td><td></td><td></td> </tr> <tr> <td><</td><td>C</td><td>a</td><td>n</td><td>c</td><td>e</td><td>l</td><td>;</td><td></td><td>></td><td>C</td><td>o</td><td>n</td><td>f</td><td>i</td><td>r</td><td>m</td><td></td><td></td><td></td> </tr> </table>	A	r	e		y	o	u		s	u	r	e									<	C	a	n	c	e	l	;		>	C	o	n	f	i	r	m			
A	r	e		y	o	u		s	u	r	e																													
<	C	a	n	c	e	l	;		>	C	o	n	f	i	r	m																								
<p>Press [◀] to cancel the changes (the unit will reset and the display returns to the operating screen).</p>																																								
<p>Press [▶] to confirm the changes. The changed value will be blinking for a few seconds. After this, the display returns to the operating screen.</p>																																								
<p>NOTICE:</p>																																								
<p>Using the [MENU] button during the User lock display, will reset the boiler and the boiler will return to the operating screen. Changes will be neglected in this case.</p>																																								

10.16 Setting the parameters at the control panel

The functions of the controller are embedded in the electronics by means of parameters. The values and settings hereof can be programmed by a skilled and trained service engineer with the help of a computer (laptop), the correct software and an interface cable. A selection of these parameters can be programmed at the control panel of the unit itself, without the use of a computer.

The following table gives a list of these last-mentioned parameters. NOTICE: Only the password for level 1 is issued in this manual. "More advanced" parameters need to be programmed by a skilled and trained service engineer with access to level 2.

When 'Modify = no', the parameter can only be programmed at level 2						PASSWORD: 1342
MENU	PARAMETER	DESCRIPTION	UNITS	TEXT DISPLAY	LEVEL 1 Modify	
HEATING	A	1 P5BE	Step modulation (1=on 0=off)	-	S t e p m o d u l	no
		2 P5AO	Blocking offset flow temperature control	°C	H E s O f f 1 3	yes
		3 P5AP	Proportional range temperature control	°C	H E s P r b 1 3	no
		4 P5AL	Hysteresis CH Flow temperature control	°C	H E s c D i f 1 3	yes
		5 P2IC	Integration time temperature control	s	H E s I n t 1 3	no
		6 P2MI	Blocking offset cascade temperature control	°C	H E c O f f 3	yes
		7 P2MJ	Proportional range cascade temperature control	°C	H E c P r b 3	no
		8 P2MK	Integration time cascade temperature control	s	H E c I n t 3	no
		9 P5AB	Timer Contact (1=on)	-	T i m e r C o n t	yes
DHW	B	1 P4AB	DHW Pump Config 0=Pump 1=TWV	-	D H i p m p / t w v	yes
		2 P5CB	Flow temperature DHW tank low	°C	D H i f l o w L O	yes
		3 P5CK	Flow temperature DHW tank hi	°C	D H i f l o w H I	yes
		4 P5CL	Low Flow temperature time DHW	min	D H i L O t i m e	yes
		5 P5CD	Legionella temperature	°C	L e g i o t e m p	no
		6 P5CI	Legionella hyst DHW tank temperature	°C	L e g i o h y s t	no
		7 P5CJ	Legionella hold time (0=off)	min	L e g i o h o l d	no
		8 P2KI	CH interrupt by Legionella (0=yes)(1=no)	-	L e g i o i n t r	no
		9 P2LC	Regulation temperature offset DHWd	°C	D H d s c O f f 2	yes
		A P2MN	Proportional range DHWd modulation	°C	D H d s c P r b 2 3	no
		B P2LD	Regulation temperature hysteresis DHWd	°C	D H d s c D i f 2	yes
		C P2MO	integration time DHWd modulation	s	D H d s c I n t 2 3	no
		D P2ML	Sys temp blocking offset DHW tank	°C	D H d s c O f f 3	yes
		E P2MM	Sys temp blocking hysteresis DHW tank	°C	D H d s c D i f 3	yes
F P5CA	Hysteresis DHW tank temperature	°C	D H i s c D i f 4	yes		
G P2KH	Gradient heat demand detect DHW tank temp.	°C	D H i d e t g r a d	yes		
CASCADE	C	1 P2MA	Max number extra boilers	-	M a x C a s c U n t	no
		2 P5DA	Bus address boiler	-	B u s a d r e s s	no
		3 P5DC	Dhw on entire cascade(0) only master(1)	-	D H i c a s / m a s	no
		4 P5DE	Extra Boiler output enable(1)	-	E x t r a u n i t	yes
		5 P5DF	Cascade detection (0=standalone 1=Leader)	-	C a s S i / M a	no
		6 P5BL	Power off total cascade (1)	-	P w r O f f T o C a	no
		7 P5DB	Number of boilers with common flue 0=None	-	C o m F l u N u m	no
GENERAL	D	1 P5BB	Analogue input Config (0=off 1=temp 2=power)	-	A n I n p C o n	yes
		2 P5AI	Minimum Temperature 0-10V input	°C	0 - 1 0 M i n T m p	yes
		3 P5BI	Altitude (in amounts of 100 ft.)	ft*100	A l t * 1 0 0 f t	yes
		4 P2LK	Max cooling time	min	M a x C o o l T i m	yes
		5 P5BJ	Temperature display 1=on	-	T e m p O n D i s p	yes
		6 P4AA	DHW 0=off 1=Indirect 2=Direct	-	D H W 1 = i 2 = d	no
		7 P4AD	pressure 0=off 1=sensor and 2=switch	-	c o n f i g	no
		8 P4BD	Gas type values 0-2	-	g a s t y p e	no
		9 P4BE	Soft start type values 0-2	-	c o n f i g	no
		A P5BN	Pump modes 0-4	-	c o n f i g	no

For extensive explanation see Ch. 0: 'Controlling options and settings', page 82 ff.

IMPORTANT: Do not change the parameters P2LC, P2LD, P2ML, P2MM and P5BI; they serve different purposes than CH control. Changing these parameters may affect boiler operation negatively.

Parameter screens + concise explanation see next pages →

Operating screen:
H E A T I N G : b o i l e r o f f
> > > : 1 2 3 . 4 ° C (1 2 3 . 4 ° C)

Press [MENU]

Select "Parameter" using [◀] & [▶] and press [ENTER]

Parameter menu:
I n s t a l l e r c o d e
0 0 0 0

Enter the 4-digit code with the [◀] & [▶] and the [▲] & [▼] buttons and select [ENTER]

The code will blink a few seconds and when entered correctly, the following parameters will be displayed.

NOTICE: These codes are user based and give access to a selected number of parameters, which can be changed (Installer level 1/2).

Menu A: Heating
A 1 S t e p m o d u l
1

Function to activate the step modulation:
 0 = Off
 1 = On

Menu A: Heating
A 2 H E s o f f 1 3
4 ° C

CH supply temperature setting. This parameter is the offset of the programmed CH temperature.

Menu A: Heating
A 3 H E s P r b 1 3
2 5 ° C

Select the CH supply temperature control. This parameter is the proportional range of the selected CH supply temperature.

Menu A: Heating
A 4 H E s c D i f 1 3
1 0 ° C

Select the CH supply temperature control. This parameter is the hysteresis of the selected CH supply temperature.

Menu A: Heating
A 5 H E s I n t 1 3
6 0 S e c

Select the CH supply temperature control. This parameter is the integration time of the selected CH supply temperature.

Menu A: Heating
A 6 H E c O f f 3
4 ° C

Select the cascaded boilers supply temperature control. This parameter is the offset of the selected CH supply temperature of EACH boiler of the total cascade.

The screen texts on these pages are standard part of the software and apply to CH systems (boilers) and/or DHW devices (water heaters).

Menu A: Heating

A	7					H	E					c	P	r	b		3					
												2	5				°	C				

Select the cascaded boilers supply temperature control.
 This parameter is the proportional range of the selected CH supply temperature of EACH boiler of the total cascade and of the external (cascade) sensor.

Menu A: Heating

A	8					H	E					c	i	n	t		3				
												8	0				S	e	c		

Select the cascaded boilers supply temperature control.
 This parameter is the integration time of the selected CH supply temperature of EACH boiler of the total cascade and of the external (cascade) sensor.

Menu A: Heating

A	9					T	i	m	e	r	C	o	n	t							
											0										

Function to activate "external time controller":
 0 = Off
 1 = On
 Connect to 13-14. Contact closed = daytime setting,
 Contact open = night-time setting.

Menu B: Hot water

B	1					D	H	i	p	m	p	/	t	w	v						
											1										

Hot water function of the boiler by:
 0 = pump
 1 = 3-way valve

Menu B: Hot water

B	2					D	H	i	f	l	o	w		L	O						
											2	5					°	C			

Hot water function of the boiler. This parameter is the CH supply temperature LOW level with an indirect hot water demand.

Menu B: Hot water

B	3					D	H	i	f	l	o	w		H	I						
											8	5					°	C			

Hot water function of the boiler. This parameter is the CH supply temperature HIGH level with an indirect hot water demand.

Menu B: Hot water

B	4					D	H	i		L	O	t	i	m	e						
											1			M	i	n					

Hot water function of the boiler. This parameter is the selectable period after which the boiler switches from LOW to HIGH set point with an indirect hot water demand.

The screen texts on these pages are standard part of the software and apply to CH systems (boilers) and/or DHW devices (water heaters).

Menu B: Hot water

B	5					L	e	g	i	o	t	e	m	p					
										8	5			°	C				

Pasteurisation function of the boiler. This parameter is the selected hot water temperature during the pasteurisation function of the boiler.

Menu B: Hot water

B	6					L	e	g	i	o	h	y	s	t					
										2				°	C				

Pasteurisation function of the boiler. This parameter is the selected hysteresis during the pasteurisation function of the boiler.

Menu B: Hot water

B	7					L	e	g	i	o	h	o	l	d					
										2				M	i	n			

Pasteurisation function of the boiler. This parameter is the selected period for the pasteurisation function of the boiler.

Menu B: Hot water

B	8					L	e	g	i	o	i	n	t	r					
										0									

Pasteurisation function of the boiler. This parameter controls if the CH demand can be interrupted by the pasteurisation function of the boiler.

0 = Yes

1 = No

Menu B: Hot water

B	9					D	H	d	s	c	O	f	f	2					
										4				°	C				

Function for the direct hot water boiler.
This parameter is de off set of the selected HW temperature of the boiler.

Menu B: Hot water

B	A					D	H	d	s	c	P	r	b	2	3				
										2	0			°	C				

Function for the direct hot water boiler.
This parameter is the proportional range of the selected HW temperature of the boiler.

Menu B: Hot water

B	B					D	H	d	s	c	D	i	f	2					
										1	0			°	C				

Function for the direct hot water boiler.
This parameter is the hysteresis of the selected HW temperature of the boiler.

The screen texts on these pages are standard part of the software and apply to CH systems (boilers) and/or DHW devices (water heaters).

Menu B: Hot water

B	C					D	H	d	s	c	I	n	t	2	3				
									2	0	0			S	e	c			

Function for the direct hot water boiler.
This parameter is the integration time of the selected HW temperature of the boiler.

Menu B: Hot water

B	D					D	H	d	s	c	O	f	f	3					
											4		°	C					

Function for the cascaded direct hot water boilers.
This parameter is the offset of the selected HW temperature of the cascaded boilers.

Menu B: Hot water

B	E					D	H	d	s	c	D	i	f	3					
											8		°	C					

Function for the cascaded direct hot water boilers.
This parameter is the hysteresis of the selected HW temperature of the cascaded boilers.

Menu B: Hot water

B	F					D	H	i	s	c	D	i	f	4					
											5		°	C					

Function for the indirect hot water supply of the boiler (tank).
This parameter is the hysteresis of the selected HW temperature of the calorifier/tank.

Menu B: Hot water

B	G					D	H	i	d	e	t	g	r	a	d				
											3		°	C					

Function for the indirect hot water supply of the boiler (tank).
This parameter detects an (an accelerated) hot water demand, when a larger (water) amount is being used.

Menu C: Cascade

C	1					M	a	x	C	a	s	c	U	n	t				
									1	1									

Function for the cascading of the boiler(s).
This parameter sets the total number of cascaded boilers. (Max. 12 boilers).

Menu C: Cascade

C	2					B	u	s	a	d	d	r	e	s	s				
									0										

Function for the cascading of the boiler(s).
This parameter determines the address of the boiler for the total cascading control.
Master = 0, Slave 1 = 1 etc.

Menu C: Cascade

C	3					D	H	i	c	a	s	/	m	a	s				
									0										

Function for the cascading of the boiler(s).
This parameter determines if only the Master boiler or all boilers of the cascade are used for indirect hot water.
0 = All
1 = Master

The screen texts on these pages are standard part of the software and apply to CH systems (boilers) and/or DHW devices (water heaters).

The screen texts on these pages are standard part of the software and apply to CH systems (boilers) and/or DHW devices (water heaters).

Menu C: Cascade

C	4					E	x	t	r	a			u	n	i	t				
												0								

Function for the cascading of the boiler(s).
This parameter is activated when an external (extra) boiler is connected to the Master boiler. Connect to the Master connections 21-22.

Menu C: Cascade

C	5					C	a	s		S	i	/	M	a						
												0								

Function for the cascading of the boiler(s).
This parameter sets the function of the boiler at a cascade alignment
0 = Single / Slave unit
1 = Master unit

Menu C: Cascade

C	6					P	w	r	O	f	f	T	o	C	a					
												0								

Function for the cascading of the boiler(s).
This parameter determines the function of the Slave boilers when the Master boiler is switched off.
0 = Slave boiler(s) continue operation
1 = Slave boiler(s) switch off

Menu C: Cascade

C	7					C	o	m	F	l	u	N	u	m						
												0								

Function for the cascading of the boiler(s).
This parameter determines the number of cascaded boilers, that are implemented with a common flue system.

Menu D: General

D	1					0	-	1	0	V	c	o	n	t	r					
												0								

Function for the external control of the boiler by using a 0-10 Volt signal (Connections 15-16).
0 = No external control
1 = Control based on temperature setting
2 = Control based on power setting

Menu D: General

D	2					0	-	1	0	M	i	n	T	m	p					
												2	0		°	C				

Function for the external control of the boiler by using a 0-10 Volt signal (Connections 15-16).
Control based on temperature (setting 1).
The minimum (desired) CH water temperature when supplying a 1,4 Volt signal.

Menu D: General

D	3					A	l	t		*		1	0	0	f					
												0								

Function for setting the location height (above sea level) of the boiler.
NOTICE: dimensions in English feet. One unit = 100 ft.
Use this function only in consultation with the supplier/manufacturer.

10.17 Fault codes display

The following graphs describe the lock out codes of the boiler. A lock out code can only be removed by a manual resetting of the boiler. NOTICE: Before resetting the boiler always check the boiler, central heating system and all components corresponding to the related lock out description. Never just reset the boiler, before analysing the possible cause of failure.

10.17.1 LOCK-OUT CODES

Having a lockout means that the boiler needs a manual reset to start operating again. When the boiler is in lockout the backlight of the display is blinking on and off.

Explanation > **9 9 9 , 5 : h r s** = time elapsed after fault & message.

Explanation > **P u m p 1 o n** = status of the pump during fault.

Display message	A P S s w i t c h								
F18	p u m p 1 o n				9 9 9 , 5			h r s	

Reason Air pressure switch is activated and exceeds the fixed period.
Or combination of NRV blocking and an F11 lock out.

Display message	C l i x o n F a u l t								
F15	p u m p o n				9 9 9 , 5			h r s	

Reason Heat exchanger fuse or burner door clixon exceeded maximum allowed value.

Display message	F a i l e d b u r n e r s t a r t								
F8	p u m p o n				9 9 9 , 5			h r s	

Reason Boiler is not starting after the programmed starting attempts.

Display message	F a l s e f l a m e s i g n a l								
F10	p u m p o n				9 9 9 , 5			h r s	

Reason Flame signal is detected while it cannot be expected.

Display message	F a n s p e e d i n c o r r e c t								
F11	p u m p o n				9 9 9 , 5			h r s	

Reason The controller does not detect a correct fan speed.

Display message	F l a m e l o s t								
F9	p u m p o n				9 9 9 , 5			h r s	

Reason Flame detected during normal operation, but was lost while running.

Display message	F l o w h i g h T e m p								
F1	p u m p o n				9 9 9 , 5			h r s	

Reason Flow temperature exceeds the limit which has been set in the parameters.

Display message	F l o w R e t u r n d t f a u l t								
F16	p u m p o n				9 9 9 , 5			h r s	

Reason Temperature difference between flow and return exceeds limitation value, or 'dT block or delta direct block' has occurred three times.

Display message	F l o w s e n s o r e r r o r								
F0	p u m p o n				9 9 9 , 5			h r s	

Reason Flow sensor not detected by the boiler caused by faulty connection/sensor.

Display message	F l u e s e n s o r e r r o r								
F6	p u m p o n				9 9 9 , 5			h r s	

Reason Flue gas sensor not detected by the boiler caused by faulty connection/sensor.

Display message F7	F l u e t e m p t o o h i g h
	p u m p o n 9 9 9 , 5 h r s

Reason Flue gas temp. exceeds the limit more than 3 times within a certain time frame.

Display message F5	N o n R e t u r n V a l v e
	p u m p o n 9 9 9 , 5 h r s

Reason Contact signal of the non-return valve failed.

Display message F13	P a r a m / H a r d w f a u l t
	p u m p o n 9 9 9 , 5 h r s

Reason Fault during programming of the boiler software parameters.

Display message F12	p r o g r a m m i n g e n d
	p u m p o n 9 9 9 , 5 h r s

Reason Software parameters have been programmed.

Display message F1	R e t u r n h i g h T e m p
	p u m p o n 9 9 9 , 5 h r s

Reason The maximum return temperature as set in the parameters is exceeded.

Display message F3	R e t u r n s e n s o r e r r o r
	p u m p o n 9 9 9 , 5 h r s

Reason Return sensor not detected by the boiler caused by faulty connection/sensor.

Display message F19	S i p h o n s w i t c h
	p u m p o n 9 9 9 , 5 h r s

Reason The pressure switch detects a high pressure in the flue/siphon system.

Display message F17	W a t e r h i g h l i m i t
	p u m p o n 9 9 9 , 5 h r s

Reason Maximum thermostat (clixon) measured a too high flow temperature.

10.17.2 BLOCKING CODES

The following graphs describe the blocking codes of the boiler. A blocking code is only a temporary blocking of the boiler, because of an extraordinary situation. The boiler will continue to operate after stabilisation of this situation.

The display is not blinking, but is lightened up during the blocking period.

The boiler is blocking an action because of an extraordinary situation. The action will be resumed after stabilisation of the situation.

Display message	A	n	t	i	c	y	c	l	e	t	i	m	e						
											9	9	9	,	5		h	r	s

Reason The controller received a heat demand too quick after the last ended demand.

Display message	C	a	s	c	a	d	e	B	l	o	c	k							
											9	9	9	,	5		h	r	s

Reason One of the cascaded boilers causes an error, because of a lock out.

Display message	D	e	a	i	r	a	t	i	o	n									
											9	9	9	,	5		h	r	s

Reason The boiler starts its deairation function and after will return to normal operation. This function can be activated by parameter P4AJ.

Display message	d	T		b	l	o	c	k											
											9	9	9	,	5		h	r	s

Reason Temperature difference between flow and return exceeds the blocking value but not the lock out value.

Display message	F	l	o	w		t	e	m	p		h	i	g	h					
											9	9	9	,	5		h	r	s

Reason Flow temperature has exceeded the blocking temperature, but it has not exceeded the lock-out value

Display message	F	l	u	e		t	e	m	p		h	i	g	h					
											9	9	9	,	5		h	r	s

Reason Flue gas temperature has exceeded the limit.

Display message	G	e	n		B	l	o	c	k										
											9	9	9	,	5		h	r	s

Reason The general blocking circuit is activated during operation = contact 7-8

Display message	L	i	n	e		f	a	u	l	t									
											9	9	9	,	5		h	r	s

Reason Wrong electrical power supply is connected (not 50 or 60 Hz, 220-240 Volt).

Display message	N	R	V		o	r		F	a	n		f	a	u	l	t			
											9	9	9	,	5		h	r	s

Reason Non-return valve contact signal activated.

Display message	O	u	t	d	o	o	r		s	e	n	s	o	r		f	a	i	l
											9	9	9	,	5		h	r	s

Reason Outdoor temperature has exceeded the blocking temperature.

Display message	R	e	t	u	r	n	t	e	m	p	h	i	g	h				
											9	9	9	,	5	h	r	s

Reason Return temperature has exceeded the blocking temperature, but the return temperature has not exceeded the lock-out value.

Display message	T	2	-	T	1	h	i	g	h								
											9	9	9	,	5	h	r

Reason Temperature difference T2-T1 has exceeded the blocking value.

Display message	W	a	t	e	r	p	r	e	s	s	u	r	e	f	a	u	l	t
											9	9	9	,	5	h	r	s

Reason Water pressure is too low or too high.

10.17.3 IMPORTANT MESSAGE

The following graphs describe the messages at the boiler display. Depending on the selected and activated options for the boiler, it is possible that some messages will show up at the display of the boiler. For example a maintenance message after a certain programmed date has been reached. The boiler will operate independently of these messages.

The display shows alternating the base screen and this message, while the backlight is blinking. The boiler is operating, but will count the exceeding hours.

A parameter must be changed, after service, to remove this message.

Display message	N	e	e	d	s	M	a	i	n	t	e	n	a	n			0	.	0
	I	g	n	i	t	i	o	n	c	y	c	l	e	s			h	r	s

Reason Maintenance option of total amount of ignition cycles has been reached.

Display message	N	e	e	d	s	M	a	i	n	t	e	n	a	n			0	.	0
	D	a	t	e												h	r	s	

Reason Maintenance option of the date has been reached.

Display message	N	e	e	d	s	M	a	i	n	t	e	n	a	n			0	.	0
	B	u	r	n	i	n	g	h	o	u	r	s				h	r	s	

Reason Maintenance option of total amount of burning hours has been reached.

Display message	N	e	e	d	s	M	a	i	n	t	e	n	a	n			0	.	0
	A	l	l													h	r	s	

Reason One of the abovementioned maintenance options has been reached.

11 CONTROLLING OPTIONS AND SETTINGS

11.1 General

The following paragraphs describe some general functions of the boiler and their possible use.

11.1.1 EXTRA BOILER CONTROL

When all units (cascaded) are firing at their maximum it is possible to start an extra "external" heating source. This unit can be connected to the "Burner Burning" contacts (connection 21-22).

P5DE Extra boiler output enable (1) (display C4)

When this parameter is set at 1 the contact "Burner Burning" will close, but only when all units are firing at a certain (programmable) input percentage. The standard factory setting for this function is "OFF".

11.1.2 MAX COOLING TIME

The fan will cool down the heat exchanger according to the temperature settings (parameters) of the software. With this cooling parameter the maximum run time of the fan can be programmed.

P2LK Max cooling time. (display D4)

This function is not used for central heating boilers.

11.1.3 TEMPERATURE DISPLAY ON/OFF

Selection for showing the measured temperatures in the operation display of the boiler.

P5BJ Temperature display 1=on (display D5)

The measured temperature in the operation display.

0 = not visible

1 = visible

11.1.4 WATER PRESSURE

P4AD Pressure 0=off, 1=sensor, 2=switch (display D7)

When the water pressure exceeds 4 bar a pressure switch must be used instead of the sensor (suitable till 4 bar). With the switch, pressure can go up to 6 bar. In this case, remove the pressure sensor and replace it by the pressure switch.

Now set the parameter at the control panel by changing "D7 config" from 1 into 2.

11.1.5 GAS TYPE SELECTION

Settings for gas types: natural gas, propane or butane-propane mixture (B/P).

P4 BD Gas type (0=standard, 1=propane, 2=B/P) (display D8).

This parameter is set 0 for the common used gas types such as natural gas G20 or G25.

By setting this parameter 1 for propane, fan speed is reduced.

Set this parameter 2 for B/P.

0 = standard gas (e.g.: natural gas)

1 = propane

2 = B/P

At each setting, the relevant 'Soft start' settings are automatically adjusted, depending on its main setting P4BE, see next chapter.



In case of gas conversion, paste the corresponding sticker at the appropriate position in the boiler and mark the square for the used gas type. Also mark the square, indicating that the correct value has been set for parameter P4BD.

G31 P	PROPANE PROPAN PROPANO PROPAAN	<input type="checkbox"/>	P4BD = 1	<input type="checkbox"/>
G30/G31 B/P	BUTANE/PROPANE BUTAN/PROPAN BUTANO/PROPANO BUTAAN/PROPAAN	<input type="checkbox"/>	P4BD = 2	<input type="checkbox"/>

(In the example below, 'propane' and 'P4BD = 1' have been marked).

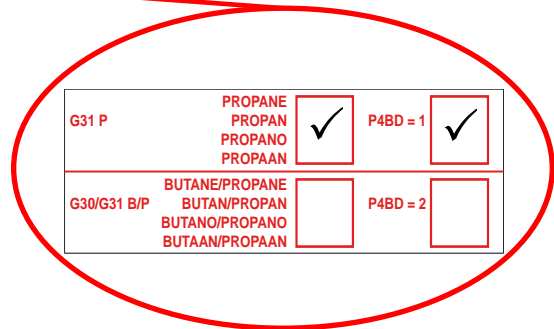
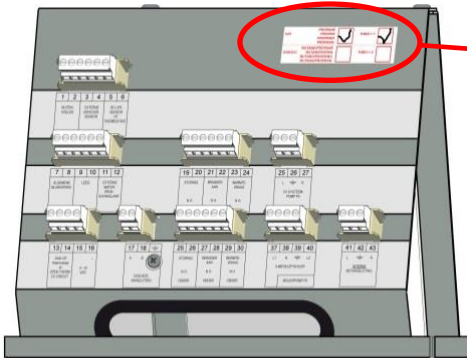

11.1.6 SOFT START OPTION

Start parameters can be modified to achieve better start behaviour, in case of noise or other difficulties. This is done by reducing the fan ramp-up speed. Two reduced settings are available (I and II).

P4 BE Soft start (0=normal, 1=reduced fan ramp-up speed (I), 2=reduced fan speed ramp-up (II)) (display D9).

- 0 = normal start-up
- 1 = reduced fan ramp-up speed (I)
- 2 = reduced fan ramp-up speed (II)

11.1.7 PUMP MODE (EC TECHNOLOGY)

When using a pump with Electronic Commutation technology and start-stop function, with a separate control connection, this parameter determines the relay for switching the pump on and off.

P5 BN Pump mode (0=modulating, 1=relay1, 2= relay2, 3= relay3, 4= do not use) (display DA).



Do not use the 230 Vac relay for the main power supply of the pump, but directly connect the pump to the mains of the boiler.

Pumps with an on/off control can be switched by one of the relay connections "lock-out", "burner burning" or "heat demand" (called 1, 2 and 3). Choose a connection which is not yet used.

- 0 = Normal mode.
- 1 = Start-stop through relay **1**, connector 19 and 20 (lock-out)
- 2 = Start-stop through relay **2**, connector 21 and 22 (burner burning)
- 3 = Start-stop through relay **3**, connector 23 and 24 (heat demand)
- 4 = Do not use (reserved for future applications).

11.2 Heating

The following paragraphs describe the different functions of the boiler and their related “controlling behaviour settings” as a central heating boiler.

11.2.1 CONTROLLING BEHAVIOUR SETTINGS

The factory settings for all heating applications are working fine and it is therefore advised not to change these settings. If changes are needed always consult the manufacturer for advice.

P5 AO Blocking offset flow temperature control (display A2).

The amount of degrees the measured temperature exceeds the active flow temperature set point before the heat demand stops. Only active when the unit is controlled by the internal flow sensor (S1) and used for single unit control. *(not used!)*

P5 AL Hysteresis CH Flow temperature control (display A4).

The amount of degrees that the measured temperature must drop, relative to the active flow temperature set point + Offset (Parameter P5 AO), before the heat demand starts. This function is active when the unit is controlled by the internal flow sensor (S1) and used for single units. When controlling cascaded units with an external system sensor (S3), this sensor will be used. *(not used!)*

P5 AP Proportional range single heating boiler (display A3).

The proportional range for controlling the flow temperature of the boiler. This function is active when the unit is controlled by the internal flow sensor (S1) and used for single units. When controlling cascaded units with an external system sensor (S3), this sensor will be used. *(not used!)*

P2 MI Blocking offset System CH temperature control (display A6).

The amount of degrees the measured temperature exceeds the active flow temperature set point before heat demand stops. Only active when the unit is controlled by an external system sensor (S3).

The following graph shows the relation between the several parameters.

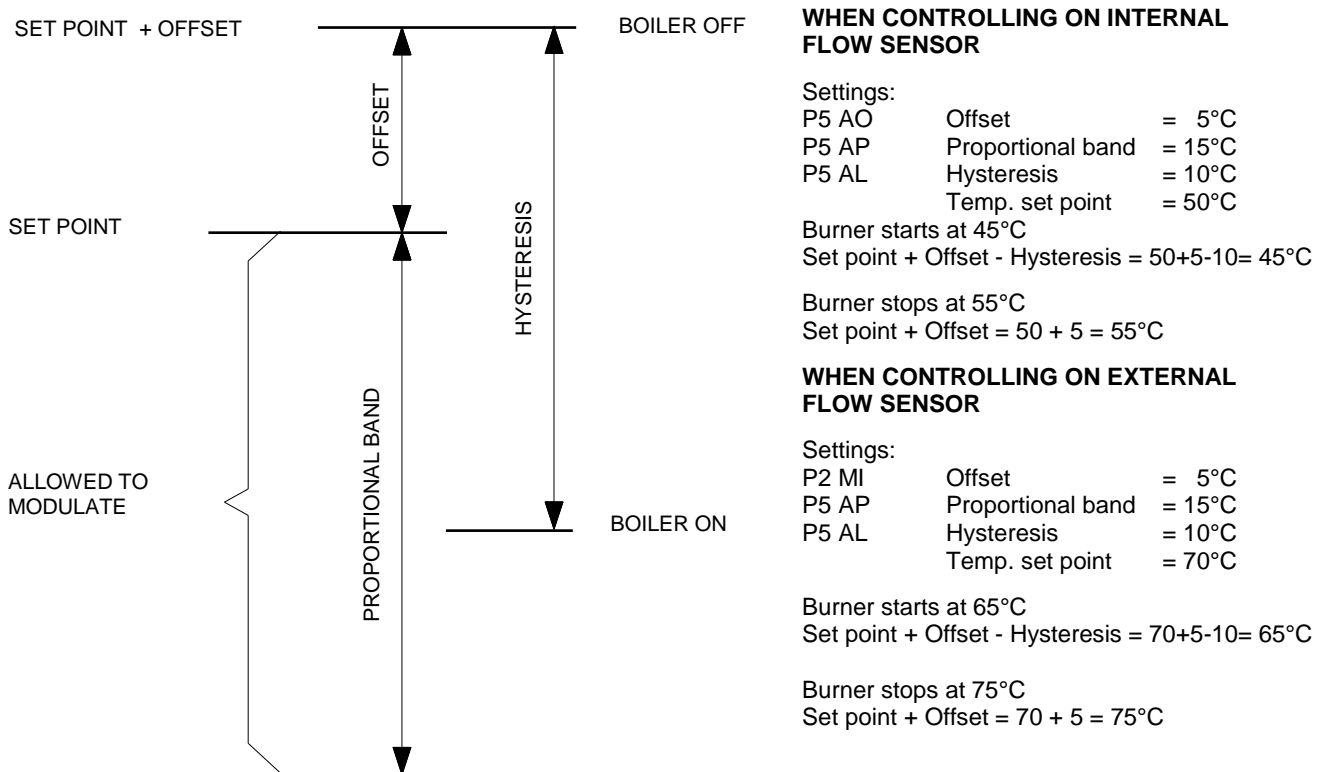

Curve and values only for illustration purposes, programmed parameter values can deviate!

11.2.2 ROOM THERMOSTAT ON/OFF

A room thermostat with a fixed set point and using an ON/OFF control can be connected to the boiler (connections 13-14). Changing the flow temperature set point and activation of a timer program can be done by this room thermostat or by programming the boiler settings. See chapter 10.10

11.2.3 ROOM THERMOSTAT OPENTHERM

An RC OpenTherm controller can be connected to the boiler for temperature reading(s) and remote programming (connections 13-14).

11.2.4 OUTSIDE TEMPERATURE RELATED FLOW CONTROL

The flow temperature set point can be calculated by using the measured outside temperature for controlling the boiler. See for detailed information chapter 10.11.

11.2.5 0-10 VDC REMOTE FLOW TEMPERATURE SET POINT

The flow temperature set point is controlled by connecting an external 0-10 Vdc signal to the boiler (connections 15-16).

P5 BB Analogue input Config (0=off 1=temp 2=power) (display D1).

This parameter must be set at "1" so the supplied 0-10V dc signal will control the temperature set point. Possible settings are:

- 0 = 0-10V control off
- 1 = 0-10V temperature set point control active
- 2 = 0-10V burner input control active

P5 AI Minimum Temperature 0-10V input (display D2).

The standard starting temperature of the heat demand, when the minimum voltage signal is sent to the boiler.

The factory settings for all heating applications are working fine and it is therefore advised not to change these settings. If changes are needed always consult the manufacturer for advice.

See also the following graph for the relation between the temperature and the control signal.

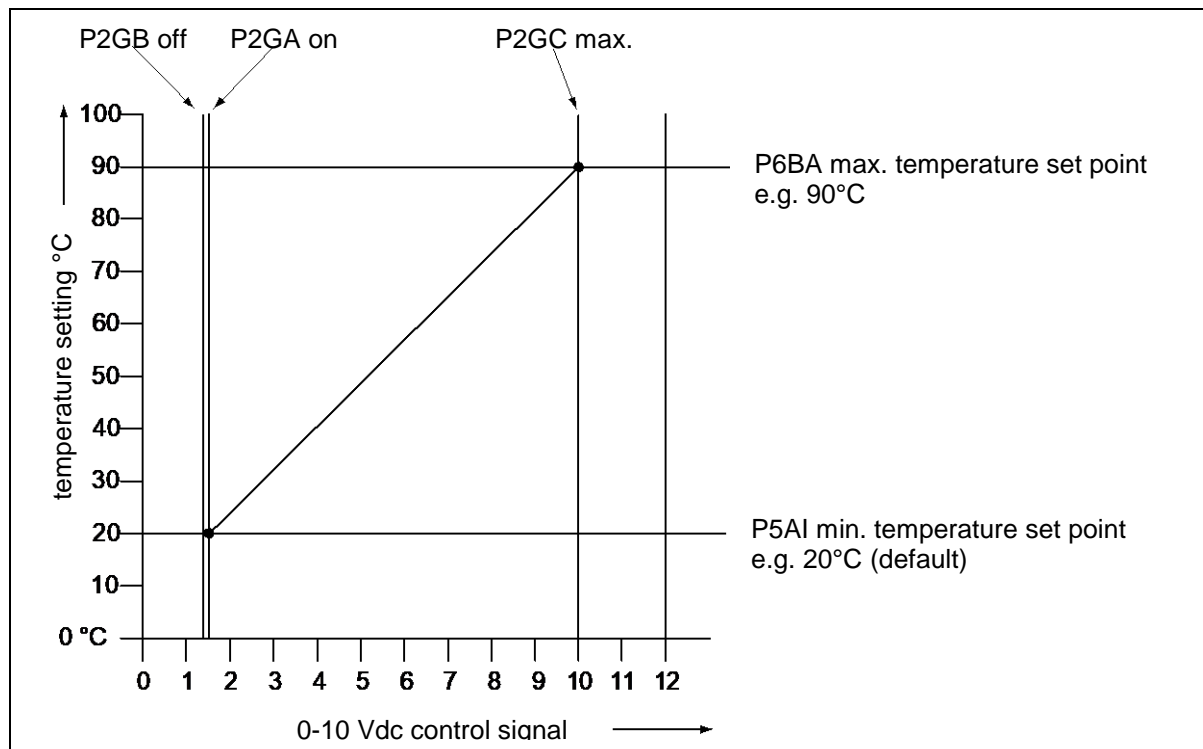

Curve and values only for illustration purposes, programmed parameter values can deviate!

11.2.6 0-10 VDC REMOTE BURNER INPUT CONTROL

The burner input is controlled by connecting an external 0-10 VDC signal to the boiler (connections 15-16).

P5 BB Analogue input Config (0=off 1=temp 2=power) (display D1).

This parameter must be set at "2" so the supplied 0-10V dc signal will control the burner input. The standard factory setting is '1', temperature set point control. Possible settings are:

- 0 = 0-10V control off
- 1 = 0-10V temperature set point control active
- 2 = 0-10V burner input control active

See also the following graph for the relation between the burner input and the control signal.

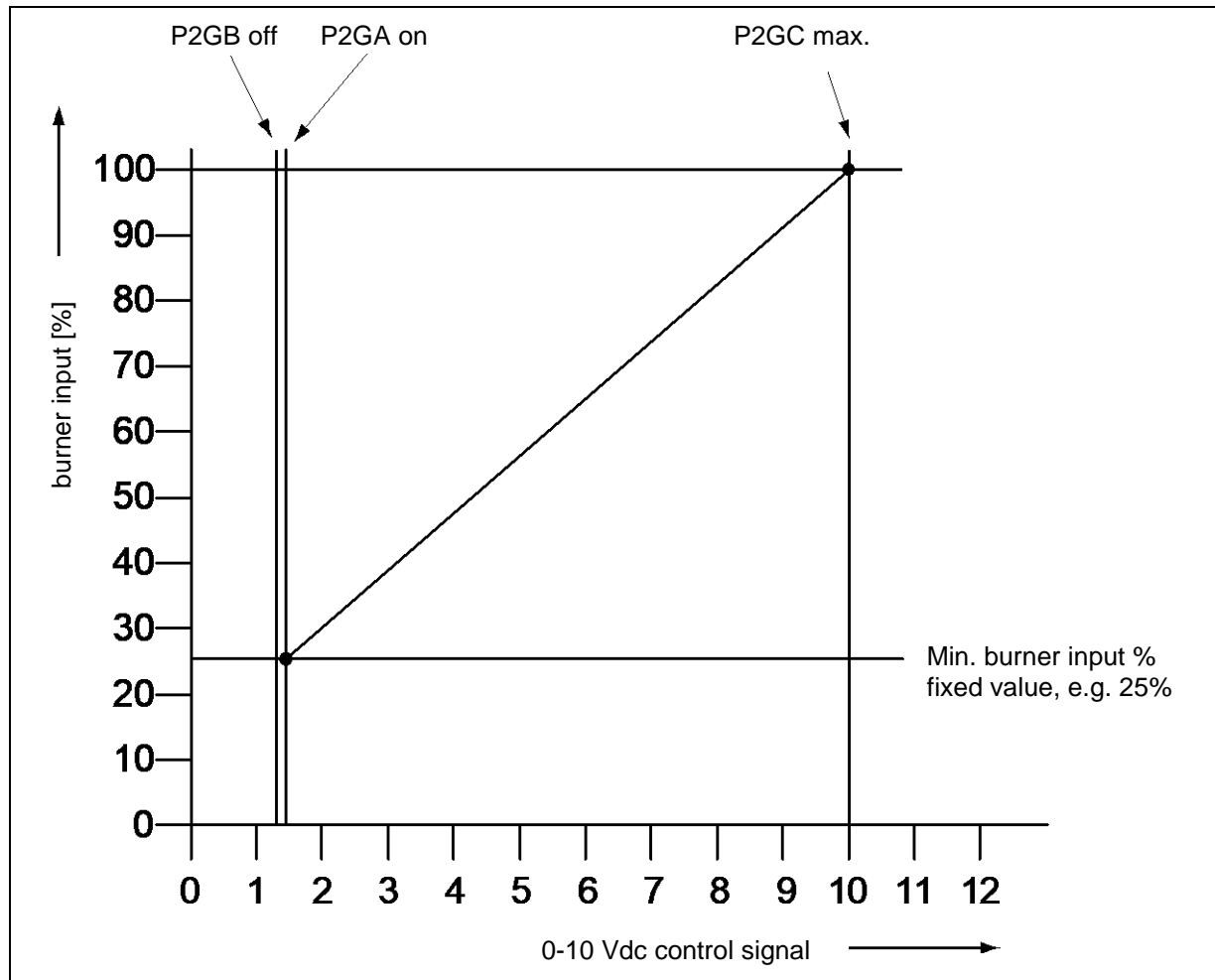

Curve and values only for illustration purposes, programmed parameter values can deviate!

11.2.7 TIMER CONTACT FUNCTION

This function can be activated when using an external night reduction timer for heating. This timer contact can be connected to the thermostat terminals (connections 13-14).

P5 AB Timer Contact (1=on) (display A9).

When this parameter is activated and:

- The thermostat terminals are bridged (timer contact closed) the normal daytime temperature is used as set point.
- The thermostat terminals are not bridged (timer contact open) the night reduced temperature is used as set point.

11.3 Indirect hot water / calorifier

The following paragraphs describe the different functions of the boiler and their related “controlling behaviour settings” as a central heating boiler with an indirect hot water function.

11.3.1 PUMP AND 3-WAY VALVE CONTROL

See chapter 19 for several installation examples of the boiler and the preferred functions. When the boiler is used as an indirect boiler for both central heating and hot water function, this hot water function can be activated by using a DHW pump or a 3-way valve.

P4 AB DHW Pump Config 0=Pump 1=TWV (display B1)

With this parameter, it is programmed if the flow to the indirect water tank (calorifier) is controlled by a pump (0 = Pump) or a 3-way valve (1 = TWV).

11.3.2 TANK THERMOSTAT

An external thermostat can be connected to the boiler. When there is a hot water demand and the tank thermostat closes, the boiler will start for the hot water demand (connections 5-6). The calorifier/tank pump will be activated or in case of a 3-way valve, this valve will turn to the position to supply heat to the tank coil(s). In case of a heat demand and hot water demand, the (central) heating pump will switch off until the hot water demand ends.

P4 AB DHW Pump Config 0=Pump 1=TWV (display B1)

With this parameter, it is programmed if the flow to the indirect water tank (calorifier) is controlled by a pump (0 = pump) or a 3-way valve (1 = TWV).

11.3.3 TANK SENSOR

A tank sensor can be connected to the boiler. The tank (hot water) set point and related controlling parameters are set in the boiler controller. A hot water demand is detected by the boiler, when the sensor (water) temperature drops below the set point. The calorifier/tank pump will be activated or in case of a 3-way valve, this valve will turn to the position to supply heat to the tank coil(s). In case of a heat and hot water demand at the same time, the heating pump will switch off until the hot water demand is stopped (water temperature is reached).

P5 CA Hysteresis DHW tank temperature (display BF)

The amount of degrees that the hot water temperature in the indirect water tank/calorifier needs to drop relative to the hot water set point, before the heat demand is transported to the tank or is diverted to the tank coil(s).

11.3.4 LOW/HIGH FLOW TEMPERATURE TO TANK COIL

This function can only be used for an “indirect” programmed boiler (parameter P4 AA = 1). Normally for a regular calorifier a fixed flow temperature of 85°C is supplied to the calorifier heat exchanger in case of a heat demand. This hot water flow will indirectly heat up the water in the calorifier tank.

The parameters for this function can be configured for both low and high calorifier operation.

This function operates as follows:

When there is a heat demand, the boiler supplies water to the heat exchanger of the calorifier, according to the flow temperature set in parameter **P5 CB**. When the heat demand remains for the period set in parameter **P5 CL**, the flow temperature set point will change to a higher temperature, which is set in parameter **P5 CK**. This situation continues until the heat demand ends.

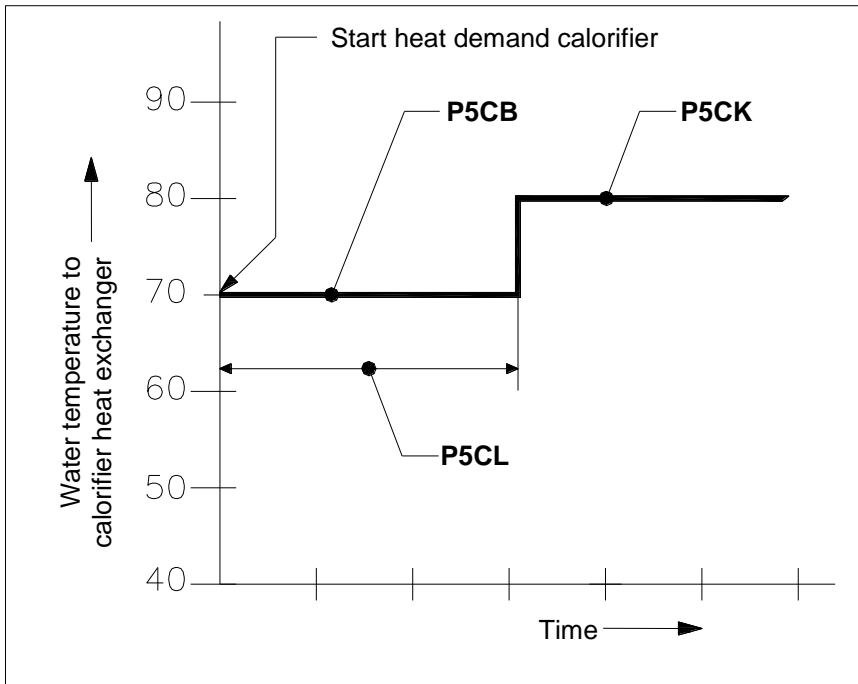

Low/high flow temperature to tank coil.

Curve and values only for illustration purposes, programmed parameter values can deviate!

The reason for this function is that the boiler by supplying a lower flow temperature to the heat exchanger of the calorifier, can stay in its condensing mode (if the temperature is low enough) and thus operate at a higher efficiency level. When it takes too long (> **P5 CL**) to heat up the tank with this low temperature mode, the flow temperature set point will change to a higher setting to make sure that the hot water set point is reached:

P5 CB Flow temperature DhW tank low (display B2)

The low level flow temperature to the tank coil(s) in case of a calorifier/indirect hot water demand. This “two staged” function is added to keep the boiler in the condensing mode as long as possible.

P5 CK Flow temperature DhW tank hi (display B3)

The high-level flow temperature to the tank coil(s) in case of a calorifier/indirect hot water demand.

P5 CL Low Flow temperature time DhW (display B4)

The programmed period for changing the set point of the water flow temperature from low to high.

The standard factory setting for this function is “OFF”.

11.3.5 HEATING AND HOT WATER SWITCHING TIME

This function can only be used for an “indirect” programmed boiler (parameter P4 AA = 1).

In case there is a heating demand and the unit is operating for this heating demand, also a hot water demand can be activated. A hot water demand always has priority, this means that the unit will switch to hot water operation. When the hot water demand remains for a longer period, there will be no heat supply for/to the central heating system during this period. Not supplying any heat for/to the central heating system might cause undesirable temperature fluctuations. The following parameters can be used to program the preferred settings.

P5 CL Low Flow temperature time DHW (display B4)

The period in which the set point of the water flow temperature (to the heating coil(s) of the calorifier) will switch from “low” to “high”.

P5 CF Max Runtime DHW during CH demand

The programmed period for the boiler to operate for DHW demand in case of a CH demand. After this period, the boiler will continue to operate for CH demand, even when there is still a DHW demand.

P5 CM Max Runtime CH during DHWi demand

The programmed period for the boiler to operate for CH demand in case of a DHW demand. After this period, the boiler will continue to operate for DHW demand, even when there is still a CH demand.

The standard factory setting for this function is that the hot water demand always has priority and that no switching between the heat and hot water demand happens, when both are active.

11.3.6 HEATING AND HOT WATER SWITCHING TIME AT A SUDDEN TEMPERATURE DROP

This function can be used to detect indirect water tank/calorifier heat demand in case of a sudden temperature drop within the range between the set point and the (minimum) value at which the boiler is normally switched on. For this parameter is chosen the value of the temperature drop detected within one second, at which an immediate indirect hot water demand is activated.

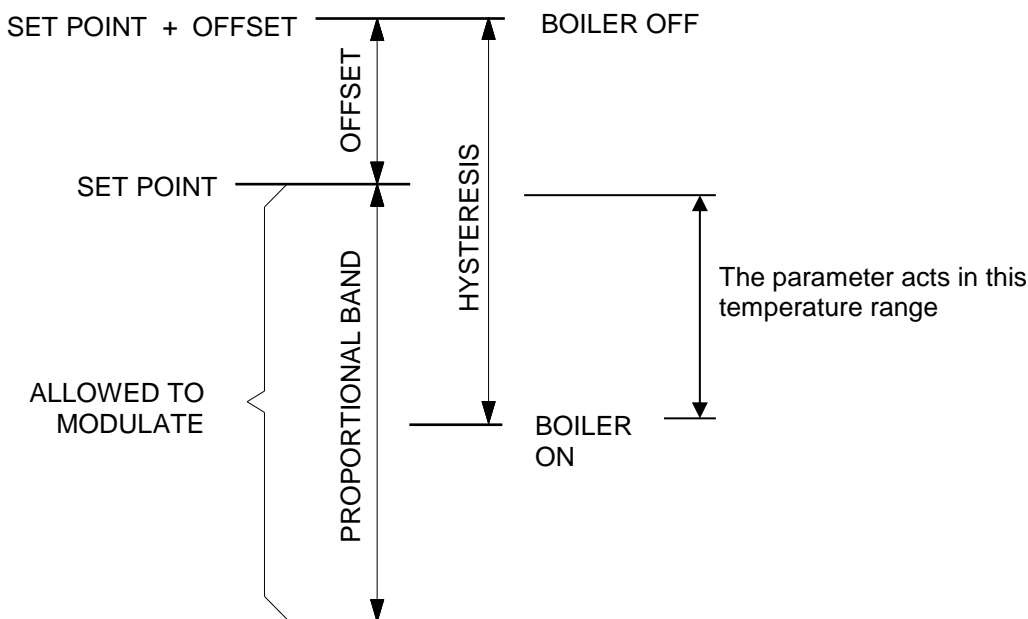

P2KH Gradient heat demand detect DhW tank temperature (display BG)

See the given explanation. The standard factory setting for this function is “OFF”.

11.3.7 ANTI-LEGIONNAIRES' DISEASE (PASTEURISATION) FUNCTION

This function can only be used for an "indirect" programmed boiler (parameter P4 AA = 1), on which a DHW program is active.

To prevent Legionnaires' disease the boiler (software) provides a function for heating up the hot water storage tank (once a week) to a higher water temperature than the normal active hot water set point. Also, the period that this "higher" water temperature function must be active, can be programmed.

NOTICE: the standard factory setting for this Legionnaires' disease (pasteurisation) function is "OFF". To activate this Legionnaires' disease, function some parameters must be programmed by the manufacturer/supplier.

The starting day and starting time of this Legionnaires' disease function can be programmed at the control panel of the boiler.

Several parameters are used for this function. Three of these parameters are shown in the following graph.

With parameter P2 KI the heating (CH) demand can be interrupted to provide heat for the anti-Legionnaires' disease demand. When no interruption is activated the boiler will wait for the end of the heat demand before the anti-legionnaire's disease function starts. The standard factory setting for this function is "OFF".

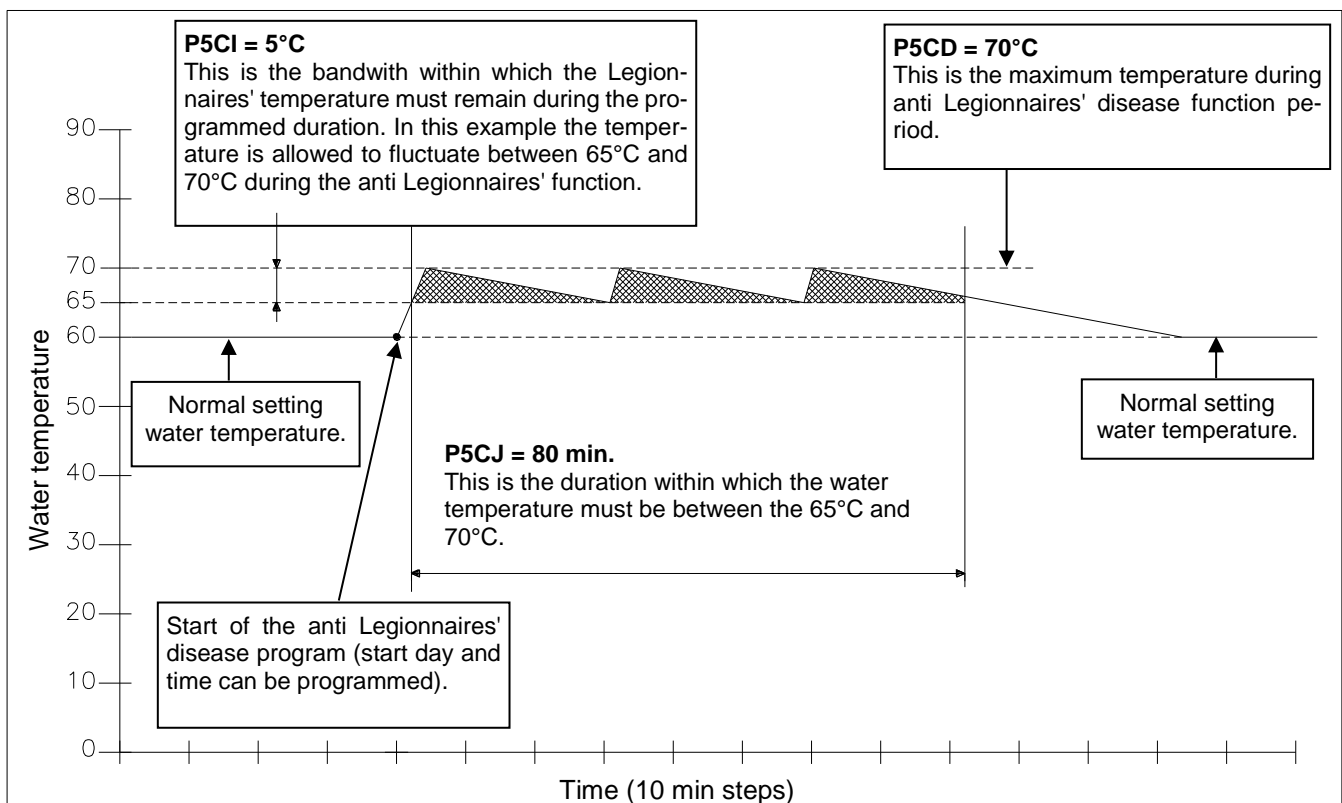

Curve and values only for illustration purposes, programmed parameter values can deviate!

The settings of these parameters P5 CI, P5 CJ and P5 CD must be programmed according to all applicable anti Legionnaires' disease preventing regulations.

The setting of these parameters can only be done by the manufacturer/supplier of the boiler or by a technician with access to programming level 2, at the control panel of the unit without the use of a computer.



NOTICE: The use and activation of this function won't guarantee a Legionnaires' disease-free installation. The responsibility for a legionnaire's disease-free installation remains at the end-user/owner.

11.4 Cascade control

Before commissioning a cascade installation, several parameters have to be changed. These parameters can be programmed on the unit itself, without the use of a computer.

NB! Remember that a S-CB+ 400 & 550 boiler is already a cascade of two burners, so cascading these boilers gives a multiple of 2-burner cascades. Each burner will be given an address and only one burner in the whole cascade will be designated Master.



Changes in parameter may only be carried out by a skilled commissioning/service engineer, who has had specific training for setting up this range of boiler. He will be able to check whether the installation functions correctly after the parameter change has been done.

For programming **all parameters** of the boilers, one needs to have a laptop with the appropriate S-CB+ software and an interface cable for connecting the laptop to the boiler control (one order no.: E400278). This software is used for programming but also shows all measured temperatures and cascade behaviour during operation and service/fault history.

11.4.1 PARAMETER SETTINGS FOR CASCADED BOILERS

Before programming the cascaded boilers, make sure that all boilers are connected (wired) with each other. Use connection 17 and 18 of each boiler.

NOTICE: Do not alternate these connections, so always connect 17 to 17 and 18 to 18.

After connection, every boiler must be programmed. This can be done at the control panel. Press the [MENU] button and select the [PARAMETER] menu. See graphics below.

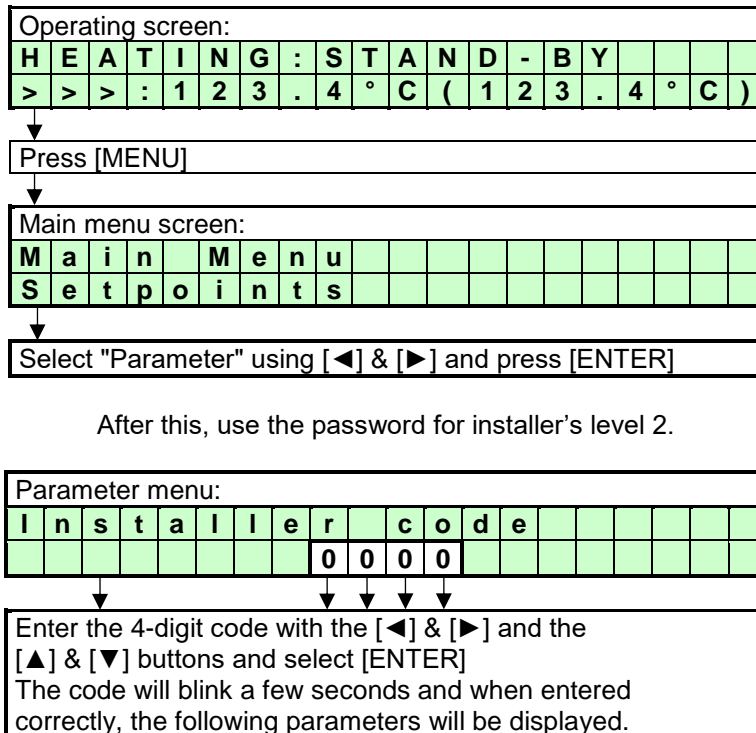

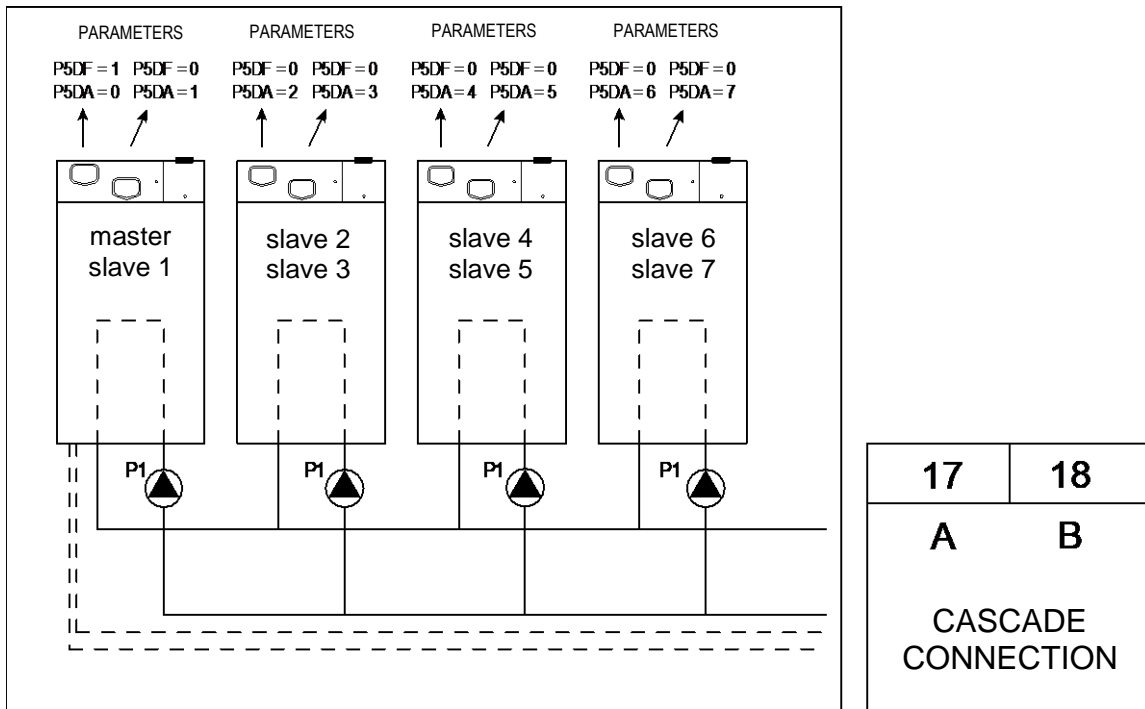

Now on each single boiler of the cascade, on both control panels, the following two parameters must be selected and programmed according to the above drawing.

Master:

C5 P5 DF 1
C2 P5 DA 0

Slave 1:

C5 P5 DF 0
C2 P5 DA 1

Slave 2:

C5 P5 DF 0
C2 P5 DA 2

And so on.

Menu C: Cascade														
C	5				C	a	s	S	i	/	M	a		
								0						
Function for the cascading of the boiler(s). This parameter sets the function of the boiler at a cascade alignment 0 = Single / Slave unit 1 = Master unit														

Menu C: Cascade														
C	2				B	u	s	a	d	d	r	e	s	
								0						
Function for the cascading of the boiler(s). This parameter determines the address of the boiler for the total cascading control. Master = 0, Slave1 = 1, etc.														

When the correct parameter is set, this must be confirmed at the confirmation screen. After activation, the value will blink for a few seconds while the parameter is programmed into the boiler.

When cascade connection is programmed correctly, the boiler display will show the following.

Explanation "Cascade communication indicator"

NO CASCADE COMMUNICATION

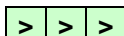
 no.1

Always showing the fixed ">>>"

CORRECT CASCADE COMMUNICATION

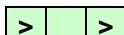
 no.1

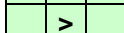
 no.2

Showing alternating no.1 & no.2 with 1 second interval.

11.4.2 MONITOR SCREENS

To obtain cascade information, see chapter 10.4.

11.4.3 OUTPUT CONTROL AND BURNER SEQUENCE

The total cascade set-up will act as one single big boiler, switching on- and off burners, depending on the total load necessary to adjust and keep the flow temperature at the calculated value.

When the heat demand rises, more burners are switched on, and when heat demand falls, one or more burners will be switched off. The burner that was switched on last, will be switched off first, see table below.

To distribute operating hours equally over all burners, the working sequence of the burners will change every two hours.

Hour	Switching ON sequence	Switching OFF sequence
X	Master – Slave 1 – Slave 2 – Slave 3 – Slave 4 – Slave 5 – Slave 6 – Slave 7	Slave 7 – Slave 6 – Slave 5 – Slave 4 – Slave 3 – Slave 2 – Slave 1 – Master
X+2	Slave 7 – Master – Slave 1 – Slave 2 – Slave 3 – Slave 4 – Slave 5 – Slave 6	Slave 6 – Slave 5 – Slave 4 – Slave 3 – Slave 2 – Slave 1 – Master – Slave 7
X+4	Slave 6 – Slave 7 – Master – Slave 1 – Slave 2 – Slave 3 – Slave 4 – Slave 5	Slave 5 – Slave 4 – Slave 3 – Slave 2 – Slave 1 – Master – Slave 7 – Slave 6
X+6	Slave 5 – Slave 6 – Slave 7 – Master – Slave 1 – Slave 2 – Slave 3 – Slave 4	Slave 4 – Slave 3 – Slave 2 – Slave 1 – Master – Slave 7 – Slave 6 – Slave 5
.....

Table: Burner sequence example of a four boiler cascade (four S-CB+ 400 & 550 boilers = eight burners).

In this table a total of four boilers (one master burner, seven slaves) is mentioned as an example, in practice the maximum number in a cascade, without extra (external) control, is six boilers (= twelve burners).

12 COMMISSIONING THE BOILER

12.1 First: flushing the boiler with water

After installation of the boiler the first step, before commissioning, is to flush the whole heating installation with fresh water to remove pollution, debris and other materials that might cause a blocking with the **S-CB+ isolated from the system**. This must also be done with heating installations, where only the boiler is replaced.

12.2 Second: filling & venting the boiler and the system

After flushing the boiler and the installation the system can be filled with fresh water. Fill the boiler and the heating system by using the appropriate filling valve. The water pressure of the system should be between a minimum of 1 bar and a maximum of 4 bar, also depending on the applied pressure safety valve - see chapter 6.14 'Water pressure.'

NOTICE: Use the following aspects to prevent corrosion of the central heating system:

- Filling water: do not use any additives for the water of the central heating system. The pH value of the water should be more than 5. If the pH value is less please contact the supplier.
- Ensure that any used "plastic" pipes are oxygen diffusion-proof in accordance with DIN 4726/4729. If not, make sure that the boiler circuit is separated from the heating circuit by a plate heat exchanger. This way no oxygen that entered the heating system through these pipes can reach the boiler.
- Check the total heating system for any leaks. This to prevent oxygen entering the system through these leaks.

This boiler has an automatic air vent situated on top of the boiler (at the roof panel). This vent must be opened during the filling of the boiler and the heating system to make sure that no air/oxygen is trapped in the heat exchanger of the boiler. NOTICE: check that the screw cap has been loosened at least one twist. Shortly after putting the boiler into operation, check the water pressure and add or lose some water to maintain the required pressure.

Make sure that no water can enter the boiler electrical parts.

12.3 Third: check the water flow

Before the boiler will be started it must be sure that the boiler pump is functioning and that there is a water flow over the heat exchanger. Check the electrical power supply of the boiler and when this is connected correctly, the display will show:

Display message	B o i l e r o f f
-----------------	---------------------

Reason Boiler is not active. To activate the boiler press [ON/OFF] button for six seconds.

Display message	H E A T I N G : b o i l e r o f f
	> > > : 1 2 3 . 4 ° C (1 2 3 . 4 ° C)

Reason Boiler is in standby mode. To activate the boiler press [ON/OFF] button for three seconds.

Activate the boiler by pressing the ON/OFF button for six resp. three seconds. After this, the following display will appear:

Display message	H E A T I N G : N o d e m a n d
	> > > : 1 2 3 . 4 ° C (1 2 3 . 4 ° C)

Reason Boiler is active, but there is no heat demand.

When there is no water present in the boiler or the water pressure is too low/high, the boiler will go into lock-out and will show a corresponding message in the display.

Display message	W a t e r p r e s s u r e f a u l t
	9 9 9 , 5 h r s

Reason Water pressure is too low or too high.

By pressing the [SERVICE] button of the boiler, the boiler can be started without a heating demand. The boiler will start to fire and also the pump will start to run. Firing of the boiler without a water flow (but filled with water!) will cause the so called “boiling noises”. Check during this “service function” operation also the flow and return temperatures of the boiler by pressing the [◀] button once. The temperature difference of the flow and return must be at least 13°C and maximum 25°C. This temperature difference indicates that there is a (enough) water flow over the boiler; this water flow prevents the heat exchanger of possible damage caused by a thermal overload.

Another safety feature of the boiler, to make sure that there is enough water flow over the boiler, is the monitoring of the flow and return temperatures (T2 and T1). When the temperature difference (delta T) between flow and return exceeds a certain (set) value, the following warning messages will be shown in the display.

Display message	T 2 - T 1	h	i	g	h														
										9	9	9	,	5			h	r	s

Reason Temperature difference T2-T1 has exceeded the blocking value which has been set in the parameters.

Display message	d T	B	I	o	c	k													
										9	9	9	,	5			h	r	s

Reason Temperature difference between flow and return exceeds the blocking value but not the lock out value.

When this delta T value exceeds the lock-out setting, the boiler will switch off and the following lock out code will be shown at the display.

Display message	F	I	o	w	R	e	t	u	r	n	d	t	f	a	u	l	t			
	F16	p	u	m	p	o	n						9	9	9	,	5		h	r

Reason Temperature difference between flow and return exceeds limitation value or ‘dT Block’ or ‘Delta direct Block’ has occurred 3 times.

When these messages appear and/or the boiler will lock out, it means that there is not enough flow over the boiler. In this case check the functioning of the pump.

The boiler has no built-in water-flow switch. If there is the possible risk of a water-flow blockage of the (external) heating system, the following pre-cautions can be taken to ensure a water flow over the boiler:

- Separate the boiler circuit from the (external) heating circuit by using a low loss header or plate heat exchanger.
- When the boiler is not equipped with an internal (built in) water pressure switch, install a water pressure switch externally, in series with the room thermostat.

During and after the commissioning of the boiler, the operation of the boiler pump must be checked, before leaving the installation room.

NOTICE: Always check the running of the pump before firing the boiler.

13 STARTING THE BOILER

13.1 General

Check the gas pressure available at the gas connection pipe of the boiler. Use the pressure nipple (4)* of the gas safety valve for this measurement. The gas input pressure for the boiler, to operate properly under the correct load, must be at least 20 mbar at high fire.

* Gas valve screws and nipples: see picture on page 101.

The boiler has two identical gas control valves: one for the top burner (MASTER) and one for the bottom burner (SLAVE 1). Both gas valves must be adjusted at maximum load and at minimum load.

Two burners are present in one heat exchanger. In fact, into one stainless steel casing, two heat exchangers have been built, a primary and a secondary. The primary exchanger, moreover, consists of an upper and a lower part. The upper part in which the top burner fires, is only transferring heat from the top burner. The lower part in which the bottom burner fires, is only transferring heat from the bottom burner. After the flue gases have passed the primary heat exchanger, they merge in the central part. In this secondary part, the remaining heat is extracted from the flue gases of both burners, causing condensation of the gases, if cooled down sufficiently.

Measuring the CO₂ percentage in the flue gas outlet outside the boiler, while both burners are burning, will result in an average CO₂ value. It is possible that this average value is correct, while the CO₂ setting of the top burner is too low and the CO₂ setting of the bottom burner is too high. Therefore, the CO₂ levels of each burner must be adjusted separately. Measurements are performed at the front, by making use of two measuring holes. See drawing.

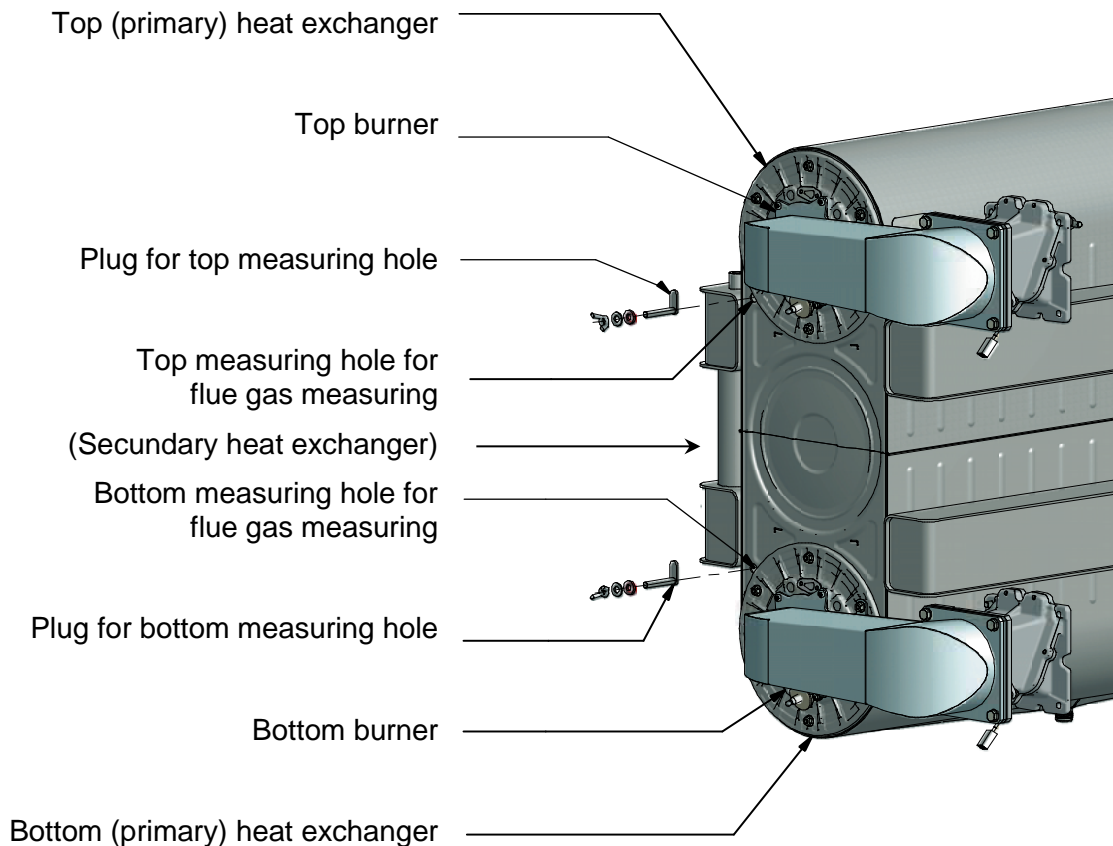

13.2 Firing for the first time

After commissioning the boiler (chapter 11.4) and avoiding any possible heat demand (remove the thermostat connection lead), the boiler displays the following message:

Display message	H	E	A	T	I	N	G	:	N	o	d	e	m	a	n	d				
	>	>	>	:	1	2	3	.	4	°	C	(1	2	3	.	4	°	C)

Reason Boiler is active, but there is no heat demand.

The display describes:

- The actual operation for heating or hot water
- If a heat demand is activated
- The temperature setting
- The temperature measured

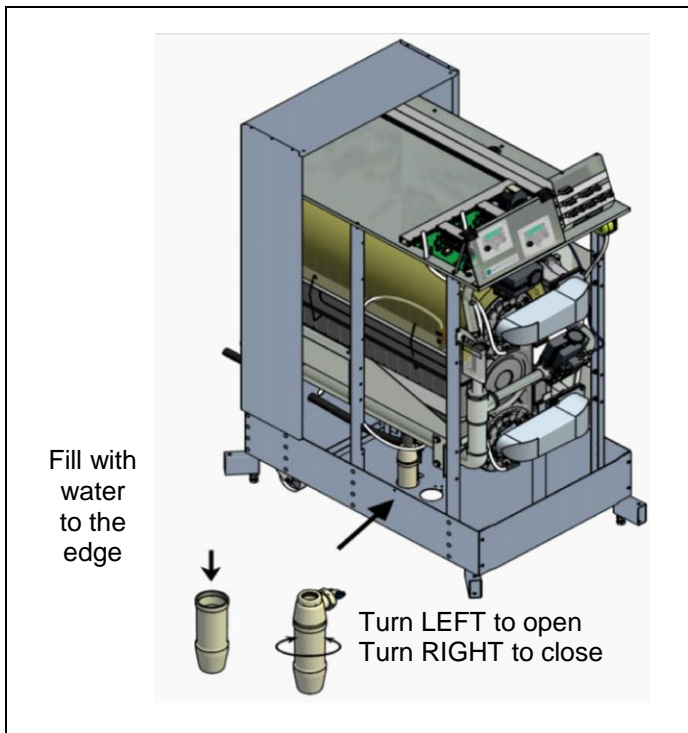

When mounting the bottom part of the siphon, before commissioning the boiler and/or after maintenance, the siphon must **ALWAYS** be completely filled with water.

This is a safety measure: the water in the siphon keeps the flue gases from entering the plant room via the condensate drain.

14 ADJUSTING AND SETTING THE BURNERS



Before carrying out any adjusting of the burner, carefully read this complete chapter.

14.1 Introduction

The burner must always be adjusted in the next situations:

- A.** - A new boiler is installed
- As part of a service/maintenance check, in case the CO₂ values turn out to be incorrect.
- B.** - The gas control safety valve has been (re)placed
- Another type of gas is applied: gas conversion

Adjustment procedures for situation A are described in chapter 14.2 and for situation B chapter 14.3

In either of the four cases described in **A** and **B**, always check the gas/air ratio of the combustion figure (CO₂) at maximum and minimum input. First set the boiler at max. load and subsequently at min. load, and repeat if necessary.

14.1.1 ADJUSTMENT TABLES

Table 1: CO₂ values for maximum and minimum load. ²⁾

Gas Type ¹⁾	CO ₂ [%]		O ₂ [%]	
	Max load	Min load	Max load	Min load
G20, G25.3	9,0 – 9,2	8,8 – 9,0	4,5 – 4,8	4,8 – 5,2
Propane³⁾ G31	10,5 – 10,7	9,8 – 10,0	4,6 – 4,9	5,7 – 6,0
B/P^{3,4)} G30/ G31	10,5 – 10,7	9,8 – 10,0	5,0 – 5,3	6,0 – 6,3

¹ Cf. EN437.
² All values measured without front door. The CO₂ / O₂ values should always be between the values set in this table. Nominal values can be found in Technical specifications datasheet page.
³ Fan settings must be changed by altering parameter P4BD (display D8). (only by a skilled mechanic).
⁴ B/P: Propane/butane mixture.



Using propane or butane/propane mixtures (B/P), maximum fan speed needs to be reduced by changing parameter P4BD.

14.1.2 ADJUSTMENT VALUES

To make adjustments easier, values of table 1 are presented in the following figures. The CO₂ / O₂ values should always be between the values set in this figure. Nominal values can be found in the Technical specifications table at the beginning of this manual. All values are measured without front door.

Gas type G20, G25.3 The CO₂ level may never be in the hatched area.

Figure 1:

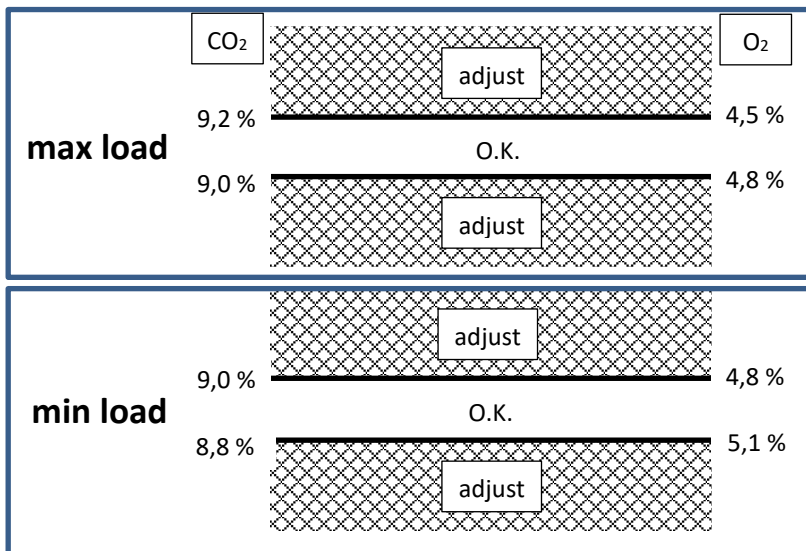

Propane G31: The CO₂ level may never be in the hatched area.

Figure 2:

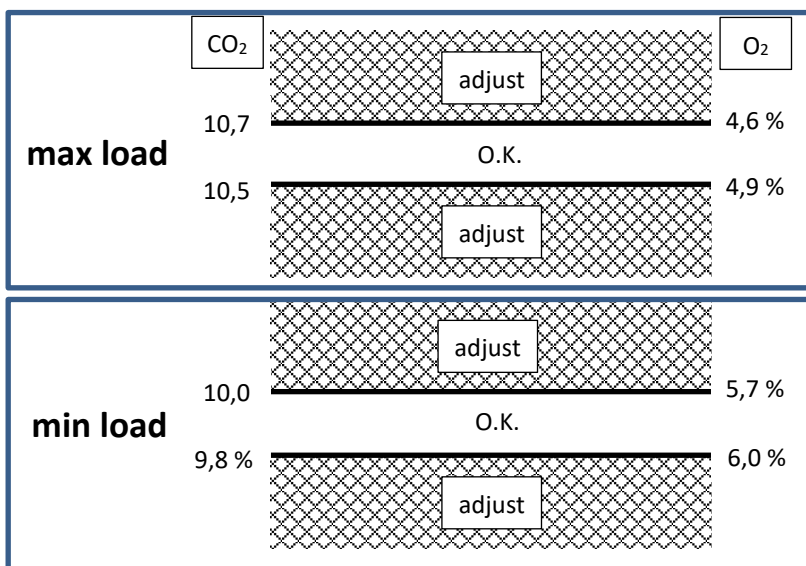

B/P: propane/ butane mixture G30/ G31: The CO₂ level may never be in the hatched area.

Figure 3:

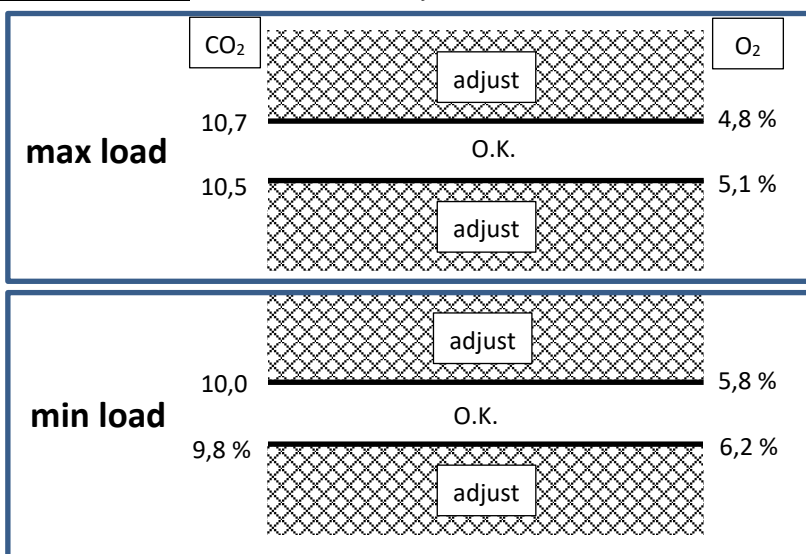



Check the setting of parameter P4BD (gas type)
0 = Standard gas; e.g.: Natural gas G20 or G25.3
1 = Propane G31
2 = Mixture of Butane/Propane, B/P (G30/G31)

Table 2

pre-adjustment settings gas valves for S-CB+ 400 & 550 BIC boilers			
boiler type	burner	number of turns open (counter clockwise)	
		nat. gas G20 ¹ and G25 ¹	propane G31 ¹ and B/P
S-CB+ 400	top	2,5	0,75
	bottom	3,0	0,75
S-CB+ 550	top	3,5	1,0
	bottom	3,5	1,0

¹ In accordance with EN437

14.1.3 GAS VALVE SETTING SCREWS: DRAWING

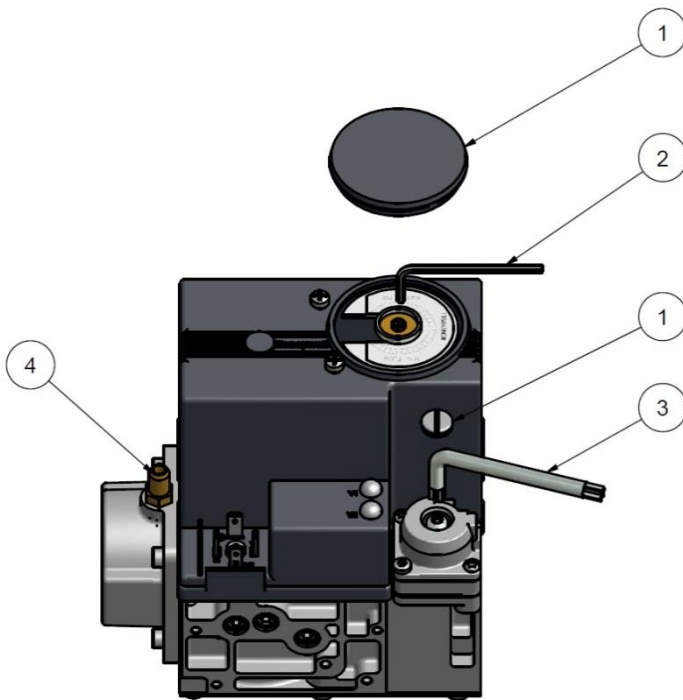

Nr.	Description
1	Remove cap
2	Adjustment at maximum load. Use Allen key no. 3 higher: turn left (CCW) lower: turn right (CW)
3	Adjustment at minimum load. Use Torx T40 key higher: turn right (CW) lower: turn left (CCW)
4	Gas supply pressure nipple

14.1.4 HOW TO REMOVE AND MOUNT THE FLUE PLUG:



Make sure during measurement in one measuring hole, that the other one is closed.

When several measurements are done in both holes alternately, the unused hole may be temporarily Scotch taped or closed by means of a rubber plug.

AFTER FINISHING ALL MEASUREMENTS, CLOSE BOTH HOLES USING THE ORIGINAL PLUGS.

Removing plug from heat exchanger:

Loosen the plug:

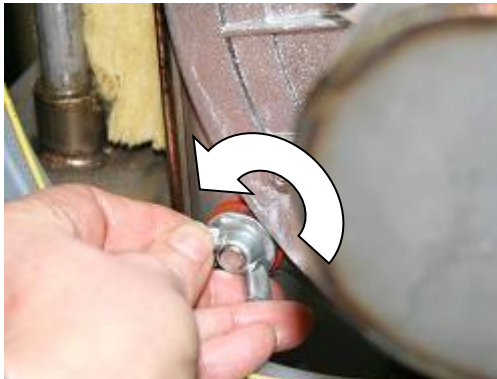

Loosen M8 wing-nut counter clockwise approximately 20 mm.

DO NOT UNSCREW THE NUT ENTIRELY FROM THE BOLT.

Pull the plug out:

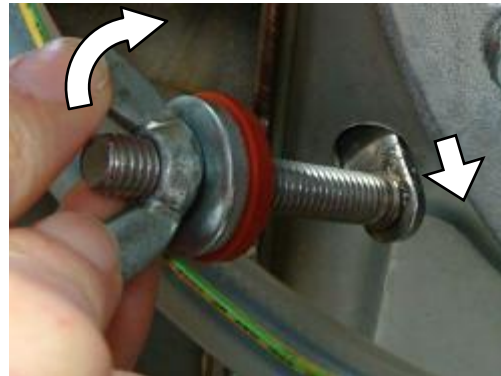

Pull and tilt the bolt so the metal lip can be extracted.

Mounting the plug:

Position the plug into heat exchanger:



Insert the metal lip upwards into the hole and tilt the bolt to a horizontal position, so the lip is completely inside the heat exchanger.

Fasten plug:

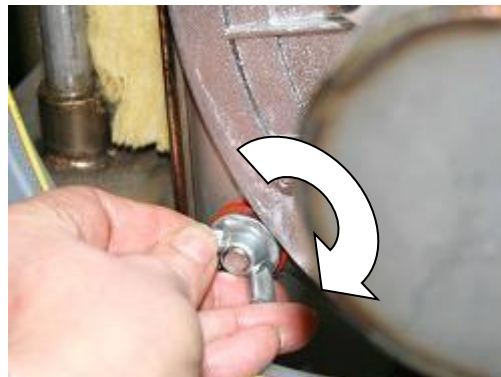

Turn the nut clockwise by hand to fasten plug.

**- DO NOT USE EXCESSIVE FORCE.
- DO NOT USE TOOLS.**

14.1.5 ADJUSTMENT ACTIONS: GENERAL SCHEME

General scheme for adjustment of the gas valve(s). Consult this scheme for an overview.

To complete all necessary adjustments in right order, follow case **A** or **B** top-down through the scheme (**B** involves a few extra steps (grey text blocks)):

GENERAL SCHEME: ADJUSTMENT STEPS		
	Case A New boiler or service check	Case B Valve replacement or gas conversion
Start	Adjusting the top burner – upper measuring hole	
Top burner	Go to service mode	In case of gas conversion: set parameter P4BD to the correct gas type at the left panel (top burner).
		First close screw [2] of the valve, then open it according to table 2.
		Go to service mode.
		If burner doesn't start, open screw [2] ¼ turn extra.
	1) <u>Maximum</u> load: check and adjust	
	2) <u>Minimum</u> load: check and adjust	
	Repeat steps 1) and 2) until measurements match table 1 or figure 1 or 2	
	Switch top burner off, proceed with bottom burner	
Next	Adjust the bottom burner – lower measuring hole	
Bottom burner	Go to service mode	In case of gas conversion: set parameter P4BD to the correct gas type at the right panel (bottom burner)
		First close screw [2] of the valve, then set it in accordance with table 2
		Go to service mode
		If burner doesn't start, open screw [2] ¼ turn extra
	1) <u>Maximum</u> load: check and adjust	
	2) <u>Minimum</u> load: check and adjust	
	Repeat steps 1) and 2) until measurements match table 1 or figure 1 or 2	
Check	check with both burners burning - 1. upper measuring hole 2. lower measuring hole	
Both burners	Set bottom burner to 50% load, start top burner and set it to 50% load	
	Set both burners simultaneously to maximum load (▲ 2x)	
	1) Check at maximum load. Measure 2x: top and bottom, and average	
	Set both burners simultaneously to minimum load (▼ 2x)	
	2) Check at minimum load. Measure 2x: top and bottom, and average	
	If measurements 1) and 2) match table 1 or figure 1 or 2, adjustment is correct	
	If the deviation is too large start all over again: check and adjust burners separately	
Boiler returns to NORMAL MODE after 40 min. OR by pressing [SERVICE] button		

14.1.6 NOTE: CO₂ MEASURING POSITION

This chapter describes the procedure for adjusting and checking CO₂ values by measuring at the front of the boiler, using the upper measuring hole for adjusting the top burner and the lower measuring hole for adjusting the bottom burner.

When both burners are on, a deviation from the single burner measurements occurs: the upper hole shows CO₂ values higher than the nominal value, the lower hole shows CO₂ values lower than the nominal value. However, the average value of the upper and lower measurements can be used to check the nominal CO₂ percentage.

If possible, measuring CO₂ in the flue gas outlet outside the boiler, at the back, is preferred. The reason is that the flue gas in the common outlet is better mixed and measurements are less deviating, regardless of whether the top or the bottom burner is on, or both. This means that measuring and adjusting is easier: neither change of measuring hole, nor averaging values is necessary.

For an extensive description consult the next two sections (choose which is applicable, **A** or **B**):

14.2 Adjusting in case of a new boiler, or after maintenance (case A)

14.2.1 GENERAL REMARK

For all adjusting steps under **A** the following must be applied: No adjustment is needed as long as measured values are within the margin of the table or figures 1 or 2.

Checking and adjusting the top burner

- Start top burner.
- On the left control panel (controlling the top burner), go to service mode: press [SERVICE] button for about four seconds. After start-up it shows:

Display message	H	E	A	T	I	N	G	:	S	e	r	v	i	c	e		3	0	%	
	>	>	>		1	2	3	.	4	°	C	(1	2	3	.	4	°	C)

Boiler is activated and operates at service mode at minimum (30% is an example)

NB! The service mode of the boiler will be active for 40 minutes. After this the boiler will return to normal operation.

Make sure that only one burner is burning: the green LED on the other panel should be off.

Also check that the fan of the bottom burner is not running: the error message "NRV or fan fault" should not be on the display of the right panel.



Maximum load adjustment.

- Press [▲] button until maximum load is reached:

Display message	H	E	A	T	I	N	G	:	S	e	r	v	i	c	e		1	0	0	%
	>	>	>		1	2	3	.	4	°	C	(1	2	3	.	4	°	C)

Boiler is activated and operates at service mode at 100% (maximum) (example).

- Measure CO₂ in the upper measuring hole (top burner).
- Adjust the CO₂ according to table 1 or figures 1 or 2 using key [2]:

Decrease CO ₂ percentage	<div style="display: inline-block; text-align: center;">CO₂ ↓</div> <div style="display: inline-block; text-align: center; margin-left: 10px;">  </div>	Turn screw [2] right (clockwise)
Increase CO ₂ percentage	<div style="display: inline-block; text-align: center;">CO₂ ↑</div> <div style="display: inline-block; text-align: center; margin-left: 10px;">  </div>	Turn screw [2] left (counter clockwise)

Minimum load adjustment.

- Press [▼] button until minimum load is reached.

Display message	H	E	A	T	I	N	G	:	S	e	r	v	i	c	e			3	0	%
	>	>	>		1	2	3	.	4	°	C	(1	2	3	.	4	°	C)

Boiler is activated and operates at service mode at minimum.

- By setting screw [3], adjust the gas valve to obtain the CO₂ value of table 1 or figures 1 or 2.

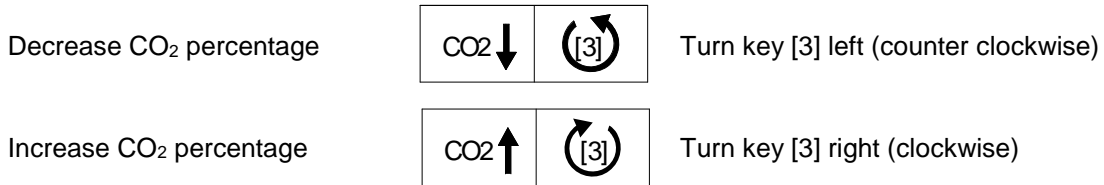

Repeat adjustments:

- Check again at maximum load and adjust if necessary.
- Check again at minimum load and adjust if necessary.
- Repeat previous steps until measurements match table 1 or figures 1 or 2.
- Switch the top burner off (press service button).

14.2.2 CHECKING AND ADJUSTING THE BOTTOM BURNER

- On the right control panel, go to service mode (press [SERVICE] button for 4 seconds). Make sure that only the bottom burner is on: the green LED on the left panel (top burner) should be off. Also check that the fan of the top burner is not running: the error message "NRV or fan fault" should not be on the display of the left panel.
- Set the load at maximum by pressing the [▲] button.
- Measure CO₂ in the lower measuring hole (bottom burner).
- Adjust the CO₂ within the values according to table 1 or figures 1 or 2 using key [2].
- Set the load at minimum by pressing the [▼] button.
- Adjust the CO₂ within the values according to table 1 or figures 1 or 2 using key [3].
- Check again at maximum load and adjust if necessary.
- Check again at minimum load and adjust if necessary.
- Repeat previous steps until measurements match table 1 or figures 1 or 2.
- Switch the bottom burner off (press [SERVICE] button).

14.2.3 CHECKING BOTH BURNERS

To switch both burners on at the same time: switch to service mode, set one burner at 50% load using the [▲] and/or [▼] buttons. While this burner is on, switch the other burner to service mode (press [SERVICE] button for 4 seconds). After start-up, set it also at 50% load.

- To set both burners at maximum load, press [▲] buttons on both panels simultaneously.
- Measure CO₂ in the upper measuring hole (top burner); a value within the margin of the table 1 or figures 1 or 2 is acceptable. Note down this value.
- Measure CO₂ in the lower measuring hole (bottom burner); a value within the margin of the table 1 or figures 1 or 2 is acceptable. Note down this value.
- Calculate the average of these two measurements: add the upper and lower values and divide by two.
- If this average CO₂ at maximum matches table 1 or figure 1 or 2 proceed with the next step: checking at minimum load. If the deviation is larger than check and re-adjust burners separately again.
- To change to minimum load, press [▼] buttons on both panels simultaneously.
- Check CO₂ for the minimum load: measure CO₂ in the upper measuring hole of the top heat exchanger; a value within the margin of the table 1 or figures 1 or 2 is acceptable. Note down this value
- Measure CO₂ in the lower measuring hole of the bottom heat exchanger; a value within the margin of the table 1 or figures 1 or 2 is acceptable. Note down this value Calculate the average of these two measurements: add the upper and lower values and divide by two.
- If this average CO₂ at minimum matches table 1 or figure 1 or 2, adjustment is correct. If the deviation is larger than, check and re-adjust burners separately again.
- If measurements at maximum and minimum match table 1 or figure 1 or 2, adjustment is completed.
- Switch burners off (press [SERVICE] buttons on both panels).

14.3 Adjusting after gas valve replacement or in case of gas conversion (case B)



In case of gas conversion, apply the corresponding sticker at the appropriate position in the boiler and mark the square for the used gas type. Also mark the square, indicating that the correct value has been set for parameter P4BD.

(In the example below, 'propane' and 'P4BD = 1' have been marked).

G31 P	PROPANE PROPAN PROPANO PROPAAN	<input type="checkbox"/>	P4BD = 1	<input checked="" type="checkbox"/>
G30/G31 B/P	BUTANE/PROPANE BUTAN/PROPAN BUTANO/PROPANO BUTAAN/PROPAAN	<input type="checkbox"/>	P4BD = 2	<input type="checkbox"/>

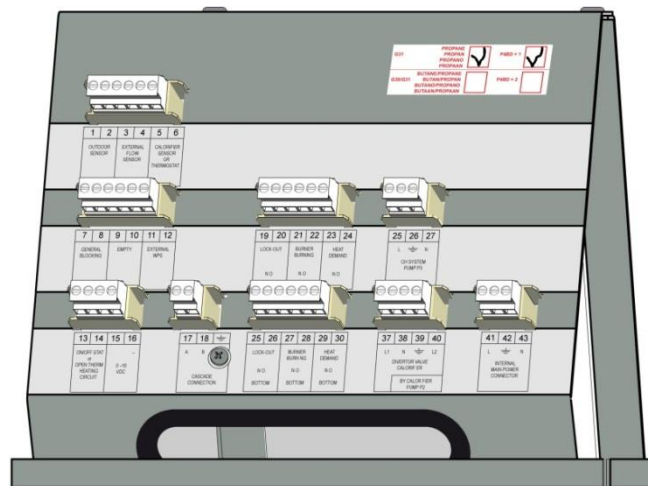

14.3.1 GENERAL REMARKS

As can be seen in the general scheme, the main adjusting steps in case **B** are the same as in case **A**, except for these extra steps:

- set the right gas group; parameter P4BD (display D8)
- a pre-adjusting step, to make sure the burner will fire

All adjustments must result in CO₂ percentages within the table or figure 1 or 2.



In case of gas conversion: check parameter P4BD for the correct setting. (See also next page →).

14.3.2 CASE **B** ADJUSTMENTS

Pre-adjusting the top burner:

- Turn setting screw [2] of the upper gas valve **clockwise** until you feel resistance. This means that the valve is closed, *do not try to tighten the screw any further.*
- Now turn this screw **counter clockwise** (open), according to the number of turns in table 2 for the used boiler and gas type.

If the burner doesn't start up in service mode, turn screw [2] an extra quarter turn counter clockwise, and try again.

Pre-adjusting the bottom burner:

- Turn setting screw [2] of the lower gas valve **clockwise** until you feel resistance. This means that the valve is closed, *do not try to tighten the screw any further.*
- Now turn this screw **counter clockwise** (open), according to the number of turns in table 2 for the used boiler and gas type.

→ proceed according to steps in chapter 14.2.2.

If the burner doesn't start up in service mode, turn screw [2] an extra quarter turn counter clockwise, and try again.

Checking both burners:

→ proceed according to steps in chapter 14.2.3.

14.3.3 SETTING PARAMETER P4BD GAS TYPE (DISPLAY D8)

In case of gas conversion, change parameter P4BD to the correct setting for both burners, for the top burner on the left control panel and for the bottom burner on the right control panel:

- start from screen showing: "no demand", "standby" or "burning"
- press [ON/OFF] button for 2 seconds to switch to programming mode: "heating: boiler off"
- press [MENU] for 3 seconds: "Main menu - Clock"
- press ◀ button to select "Main menu - parameter", press [ENTER]
- enter password level 2: press ◀▶ to select the number, press ▲▼ to adjust, press [ENTER]
- after confirmation, the display shows "A1 Step modul"
- press ◀ button to select "D8 Gas type"
- press ▲▼ to select the correct setting: 0 = standard gas; e.g.: natural gas (G20/G25.3)
1 = propane (G31)
2 = B/P (G30/G31)
- press [ENTER] to confirm, boiler returns to programming mode "heating: boiler off".
- press [ON/OFF] button for 3 seconds to switch to base screen "no demand", "standby" or "burning"

Repeat this procedure on the other panel for the other burner.

16 FAULT CODES, BLOCKING CODES

16.1 Fault codes

IMPORTANT:

To avoid electric shocks, disconnect electrical supply before performing troubleshooting. To avoid burns, allow the unit to cool before performing troubleshooting. Be aware that a fault code is an indication that the unit or the system needs attention. When repeatedly having faults, these should not be neglected. The first step is to check if the unit is installed according to the instructions. If not, first make sure the installation complies with the installation manual. Always check the fuses on the control board before replacing any major components. A blown fuse can prevent the controller or other components from operating. Most faults can also be caused by a bad wiring and/or connections, even if it is not specifically mentioned. With every fault, it is wise to check wiring and connections (at both ends) that connect to the safety device/component that generates the fault.

LOCK-OUT CODES:

Having a lockout means that the boiler needs a manual reset to start operating again. When the boiler is in lockout the backlight of the display is blinking on and off.

Explanation > **9 9 9 , 5 : h r s** = time elapsed after fault/message.

Explanation > **P u m p 1 o n** = status of the pump during fault.

Display message	A P S s w i t c h
F18	p u m p 1 o n 9 9 9 , 5 h r s
Reason	Air pressure switch activated for a certain time. Or combination of NRV blocking and an F11 lock-out.
Cause:	The fan of the non-burning burner is not able to run to prevent recirculation.
	Check the 4-wired wiring and connections at the fan and at the main control board. Check the 3-wired power supply wiring and connections at both ends. Replace the fan. Replace the main control board of that specific burner.
Cause:	It is not certain that the non-return valve of the burner, that is not burning, is closed.
Corrective action:	Check the state of the Non-Return Valve: > Is the valve moving freely to the open and closed positions. > Is there debris/fouling or corrosion in the valve to prevent the valve to move freely.

Display message	C l i x o n F a u l t
F15	p u m p o n 9 9 9 , 5 h r s
Reason:	Heat exchanger fuse exceeded maximum value.
Cause:	The thermal fuse of the heat exchanger has opened permanently.
Corrective action:	Switch off the electrical power and gas supply and contact supplier.

Display message F8	F a i l e d b u r n e r s t a r t p u m p o n 9 9 9 , 5 h r s
Reason	Boiler not operational after 4 starting attempts.
Cause:	No spark.
Corrective action:	<p>Check the ignition electrode and replace/clean if necessary.</p> <p>Check the state of the ceramic insulator. A small crack can prevent the spark to form at the end of the electrode.</p> <p>Check the distance between the electrode pin, earth pin and burner.</p> <p>Check the state of the ignition cable and replace it if necessary.</p> <p>Check the state of the earth wire/connection of the ignition and replace if necessary.</p> <p>Check the state of the sparkplug cap and replace it if necessary.</p> <p>Check power supply. Voltage must be 230 Vac nom.</p> <p>Check for proper electrical grounding of unit.</p> <p>Bad ignition transformer. Change the burner control of the unit.</p>
Cause:	Ignition spark, but no flame.
Corrective action:	<p>Check if all gas valves in the supply line are completely open.</p> <p>Check if there is no air in the gas supply (start-up new systems).</p> <p>Check if the gas valve opens. When there is power supply to the gas valve, but the valve does not open, the gas valve must be replaced.</p> <p>Check if the gas valve opens. When there is no power supply to the gas valve check the gas valve wiring/connections.</p> <p>Check if the gas valve settings are correct and adjust if necessary.</p> <p>Check if the gas pressure is correct and sufficient.</p> <p>Check if the air supply is open/not blocked.</p>
Cause:	Flame, but not enough ionisation to establish the flame.
Corrective action:	<p>Check the ignition electrode and replace/clean if necessary.</p> <p>Check the state of the ceramic insulator.</p> <p>Check the distance between the electrode pin, earth pin and burner.</p> <p>Check the state of the ignition wire (also the ionisation wire) and replace it if necessary.</p> <p>Check the state of the earth wire/connection of the ignition and replace if necessary.</p> <p>Check for proper electrical grounding of unit.</p> <p>Check power supply. Voltage must be 230 Vac nom.</p> <p>Check the state of the sparkplug cap and replace it if necessary.</p>

Display message F10	F a l s e f l a m e s i g n a l p u m p o n 9 9 9 , 5 h r s
Reason	Flame signal detected, while boiler should not fire for operation.
Cause:	The flame detection circuit detects a flame which is not supposed to be present.
Corrective action:	<p>Check the ignition/ionisation electrode and make sure it is clean (or replace it).</p> <p>Check the power supply voltage for a correct polarity.</p> <p>Check the power supply for bad frequency or voltage peaks.</p> <p>Check external wiring for voltage feedback.</p> <p>Check the internal wiring for bad connections.</p> <p>Check if the gas valve is closing correctly.</p> <p>Replace the burner control.</p>

Display message	F a n s p e e d i n c o r r e c t
F11	p u m p o n 9 9 9 , 5 h r s
Reason	Actual fan speed differs from the unit rpm set point.
Cause:	An incorrect fan speed is detected.
Corrective action:	Check the 4-wired wiring and connections at the fan and at the main control board. Check the 3-wired power supply wiring and connections at both ends. Replace the fan. Replace the main control board.
Cause:	The fan of the non-burning burner is not able to run, to prevent recirculation.
	Check the 4-wired wiring and connections at the fan and at the main control board. Check the 3-wired power supply wiring and connections at both ends. Replace the fan. Replace the main control board of that specific burner.

Display message	F l a m e l o s t
F9	p u m p o n 9 9 9 , 5 h r s
Reason	Flame signal lost during operation.
Cause:	Bad gas supply pressure.
Corrective action:	Be aware that the specified gas pressure must be met during all operation conditions. Check if all gas valves in the supply line are completely open. Check if the dirt filters mesh in the gas valve inlet is clean. Check if the external dirt filter in the gas supply line is not blocked. Check if an external gas pressure regulator is selected/installed correctly. Check the gas pressure that is supplied to the building > call the supplier if necessary.
Cause:	Bad gas valve or gas valve settings.
Corrective action:	Check and set gas valve settings.
Cause:	Bad electrode, electrode wiring/connection (bad ionisation signal).
Corrective action:	Check ionisation signal. Check the ignition electrode and replace/clean if necessary. Check the state of the ceramic insulator. Check the distance between the electrode pin, earth pin and burner. Check the state of the ignition wire (is also ionisation wire), and replace if necessary Check the state of the ignition earth wire/connection and replace if necessary. Check for proper electrical grounding of unit.
Cause:	Bad flue gas and/or air supply system.
Corrective action:	Check if the design of the flue gas and air supply system complies with the max. combined resistance as specified. Check if the flue gas and air supply system is installed according a good installation practice by a skilled installer. Check all seals in the flue gas and air supply system.
Cause:	External factors.
Corrective action:	Check if there were extreme weather/wind conditions when the fault occurred. Check if the boiler room pressure is equal to the pressure at the position of the flue gas outlet. (If combustion air is drawn from the boiler room).

Display message	F l o w h i g h T e m p
F1	p u m p o n 9 9 9 , 5 h r s
Reason:	Max. flow temperature exceeds limitation (lock-out) value.
Cause:	The water flow is restricted.
Corrective action:	Check functioning of the pump. Check/open all valves that might restrict the water flow through the unit. Check for an external system pump that influences flow through the unit. Check if the system resistance exceeds the spare capacity of the unit pump.

Display message	F l o w R e t u r n d t f a u l t
F16	p u m p o n 9 9 9 , 5 h r s
Reason:	Temperature difference between flow and return exceeds limitation value, or 'dT block or delta direct block' has occurred 3 times.
Cause:	The water flow through the unit is too low.
Corrective action:	Check functioning of the pump. Check/open all valves that might restrict the water flow through the unit. Check for an external system pump that influences the flow through the unit. Check if the system resistance exceeds the spare capacity of the unit pump. Make sure the heat exchanger is clean. Heat exchanger fouling (partly blockage) will increase the resistance causing the water flow to drop.

Display message	F l o w s e n s o r e r r o r
F0	p u m p o n 9 9 9 , 5 h r s
Reason:	Flow sensor is not detected.
Cause:	Bad wiring/connection in the flow sensor circuit.
Corrective action:	Check for loose wiring/connections in the flow sensor circuit.
Cause:	Bad temperature sensor causing a fault signal.
Corrective action:	Replace flow sensor.

Display message	F l u e s e n s o r e r r o r
F6	p u m p o n 9 9 9 , 5 h r s
Reason	Flue sensor is not detected by the boiler PCB.
Cause:	Bad wiring/connection in the flue gas sensor circuit.
Corrective action:	Check for loose wiring/connections in the flue gas sensor circuit.
Cause:	Bad temperature sensor causing a fault signal.
Corrective action:	Replace flue gas sensor.

Display message F7	F l u e t e m p t o o h i g h p u m p o n 9 9 9 , 5 h r s
Reason	Flue gas temperature exceeded three times the limitation value within a certain period.
Cause:	Heat exchanger polluted and not able to transfer enough heat to system water.
Corrective action:	Check and clean heat exchanger.
Cause:	Bad flue gas sensor or sensor connection (partly shorted).
Corrective action:	The sensor is of the type NTC. This means if the temperature rises the resistance lowers. A partly shorted sensor will drop its resistance and therefore 'measure' a raise in temperature when actually there is none. Check for moist in the sensor connections or replace sensor.
Cause:	There is no water in the unit while firing.
Corrective action:	This is an unlikely situation while all the safeties for checking the water presence didn't detect anything. Only a lot of air in the system/unit (under pressure) can cause the water pressure switch to switch while no water is present. Also the water leak detection did not react. Bleed all air from the unit so the heat from combustion can be transferred to the water and won't leave through the flue system.
Cause:	Heat exchanger failure.
Corrective action:	This is an unlikely situation but when there is severe damage to the heat exchanger, the combustion product will not be able to transfer all heat to the system water. The heat that is not transferred will convert to an increased flue gas temperature.
Display message F5	N o n R e t u r n V a l v e p u m p o n 9 9 9 , 5 h r s
Reason	NR valve contact (signal) lost for fixed amount of time. (If P2MT = 2 or 3)
Cause:	It is not proven that the non-return of the burner that is not burning is closed.
Corrective action:	Check the state of the Non-Return Valve: > Is the valve moving freely to the open and closed position. > Is there debris/fouling or corrosion in the valve to prevent the valve to move freely. Check for loose wiring/connections in the circuit to the proximity switch of the NRV Check the parameter settings of the burner controller
Cause:	It is not proven that the non-return valve of the unit is closed.
Corrective action:	Check and repair or replace NRV
Display message F13	P a r a m / H a r d w f a u l t p u m p o n 9 9 9 , 5 h r s
Reason	Failure during programming of the parameters.
Cause:	Programming of the parameters NOT successfully completed.
Corrective action:	Unit is not in stand-by mode (fan must not run during programming). Check programming wire and connections and try again. Check if the software complies with the PCB. Replace the programming wire. Replace the display PCB.

Display message F12	p r o g r a m m i n g e n d p u m p o n 9 9 9 , 5 h r s
Reason	Programming of the parameters completed successfully.
Cause:	Programming of the parameters completed successfully.
Corrective action:	This message occurs to confirm the end of programming. Pressing RESET will return the unit in normal operating status.

Display message F1	R e t u r n h i g h T e m p p u m p o n 9 9 9 , 5 h r s
Reason:	Maximum return temperature exceeds limit value.
Cause:	Systems that pre-heats the boiler return temperature too much/high.
Corrective action:	Reduce pre-heat temperature of external heat source.
Cause:	The need for heat in the system suddenly drops causing hot return water to the boiler.
Corrective action:	Dampen external heating system control to prevent sudden boiler temperature rise.

Display message F3	R e t u r n s e n s o r e r r o r p u m p o n 9 9 9 , 5 h r s
Reason	Return sensor is not detected by the boiler PCB.
Cause:	Bad wiring/connection in the return sensor circuit.
Corrective action:	Check for loose wiring/connections in the return sensor circuit.
Cause:	Bad temperature sensor causing a fault signal.
Corrective action:	Replace return sensor.

Display message F19	S i p h o n s w i t c h
	p u m p o n 9 9 9 , 5 h r s
Reason:	Siphon pressure switch detects high pressure in the flue/siphon system.
Cause:	There is too much resistance in the flue gas circuit causing high pressure in the heat exchanger at the flue gas side.
Corrective action:	Check if the flue gas system is blocked. Extreme fouling of the heat exchanger also causes the resistance to rise. Check the state of the heat exchanger and clean if necessary. Check the flue gas system diameter & length (most likely in a new system).
Cause:	The condensate drain system is blocked. The condensate will build up above the measuring point of the pressure switch and creates a static pressure larger than the measuring point.
Corrective action:	Check if the condensate drain hose between the heat exchanger and the siphon is open, so the condensate can flow freely to the siphon.
	Check if the siphon is free of debris that might block the condensate flow and clean the siphon if necessary.
	Check the condensate drain hose between the siphon and the condensate drain point in the external installation. Condensate must be able to flow freely.
Cause:	The condensate drain hose must have an open connection to the external system. If not, pressure fluctuations in the building drainage system can have effect on the pressure in the heat exchanger of the boiler.
Corrective action:	Make sure that there is an open connection between the siphon hose and the drainage system of the building installation. The condensate should flow in the drainage system through a freely "breathing" connection, so pressure fluctuations of the external drainage system cannot affect the pressure in the heat exchanger of the boiler.
Cause:	Blockage of the pressure signal hose going to the pressure switch.
Corrective action:	Check the pressure signal hose and clean or replace it if necessary.
Cause:	Bad pressure switch causing a fault signal.
Corrective action:	Replace the pressure switch.
Cause:	Bad wiring/connection in the pressure switch circuit.
Corrective action:	Check for loose wiring/connections in the pressure switch circuit.

Display message F17	W a t e r h i g h l i m i t
	p u m p o n 9 9 9 , 5 h r s
Reason:	Maximum thermostat exceeds limitation value.
Cause:	The water flow is restricted.
Corrective action:	Check functioning of the pump. Check/open all valves that might restrict the water flow through the unit. Check for an external system pump that influences the flow through the unit. Check if the system resistance exceeds the spare capacity of the unit pump.

16.2 Blocking codes

The following graph describes the blocking codes of the boiler. A blocking code is only a temporary blocking of the boiler, because of an extraordinary situation. The boiler will continue to operate after stabilisation of this situation.

The display is not blinking, but is lightened up during the blocking period. The boiler is blocking an action, because of an extraordinary situation. This action will be continued after stabilisation of this situation

Display message	A n t i c y c l e t i m e 9 9 9 , 5 h r s
Reason	The controller received a new heat demand too fast after the last ended demand.
Cause:	Opening and immediately thereafter closing of the external thermostat.
Corrective action:	Controlled water flow cools down too quickly after loss of heat demand. Controlled water flow heats up too quickly after start of heat demand. Immediately opening and closing of the external thermostat. Check switching differential of the ON/OFF thermostat. Controller settings need to be changed. Be aware that the standard settings work fine for all common systems. When anti-cycling is active, because of immediate heating or cooling of the controlled water flow/temperature, it concerns an unconventional system.

Display message	C a s c a d e B l o c k 9 9 9 , 5 h r s
Reason	Connection failure with one of the boilers of the cascade.
Cause:	The unit is programmed in such a way that none of the boilers in a cascade will fire, if one has a lockout. One unit has a lockout and therefore the whole cascade is blocked.
Corrective action:	Troubleshoot the fault of the unit in lock-out.

Display message	d T b l o c k 9 9 9 , 5 h r s
Reason	Temperature difference between flow and return has exceeded the blocking value, but not the lock out value.
Cause:	The water flow through the unit is too low.
Corrective action:	Check functioning of the pump. Check/open all valves that might restrict the water flow through the unit. Check for an external system pump that influences the flow through the unit. Check if the system resistance exceeds the spare capacity of the unit pump. Check the heat exchanger. Heat exchanger fouling (partly blockage) will increase the resistance causing the water flow to drop.

Display message	F l u e t e m p h i g h 9 9 9 , 5 h r s
Reason	Flue gas temperature has exceeded the limit.
Cause:	Heat exchanger polluted and not able to transfer enough heat to the system water.
Corrective action:	Check and clean heat exchanger.
Cause:	Bad flue gas sensor or sensor connection (partly shorted.)
Corrective action:	The sensor is of the type NTC. This means that the resistance lowers when the temperature rises. A partly shorted sensor will drop its resistance and therefore 'measure' a rise in temperature when actually there is none. Check for moist in the sensor connections or replace the sensor.
Cause:	There is no water in the unit while firing.
Corrective action:	This is an unlikely situation while all the safeties for checking the water presence didn't detect anything. Only a lot of air in the system/unit (under pressure) can cause the water pressure switch to switch while no water is present. Also the water leak detection did not react. Bleed all air from the unit so the heat from combustion can be transferred to the water and won't leave through the flue system.
Cause:	Heat exchanger failure.
Corrective action:	This is an unlikely situation but when there is severe damage to the heat exchanger, the combustion product will not be able to transfer all heat to the system water. The heat that is not transferred will convert to an increased flue gas temperature.

Display message	G e n B l o c k 9 9 9 , 5 h r s
Reason	General blocking circuit is activated during operation (general blocking contacts 7-8).
Cause:	The circuit connected to the general blocking terminals is not closed.
Corrective action:	Check all external components that are connected to the general blocking terminals and check why the contact is not closing during heat demand.
Cause: If used in combination with flow switch:	The water flow through the unit is too low.
Corrective action:	Check functioning of the pump and the flow switch. Check/open all valves that might restrict the water flow through the unit. Check for an external system pump that influences flow through the unit. Check if the system resistance exceeds the spare capacity of the unit pump. Make sure the heat exchanger is clean. Heat exchanger fouling (partly blockage) will increase the resistance causing the water flow to drop

Display message	O u t d o o r s e n s o r f a i l
	9 9 9 , 5 h r s
Reason	No outdoor sensor detected.
Cause:	The unit is programmed to check if an outdoor sensor is present and does not detect an outdoor sensor.
Corrective action:	Check for loose wiring/connections in the outdoor sensor circuit. Check the state of the outdoor sensor and replace it if necessary.

Display message	R e t u r n t e m p h i g h
	9 9 9 , 5 h r s
Reason	Return temperature has exceeded the blocking temperature, but it has not exceeded the lock-out value.
Cause:	Systems that pre-heats the boiler return temperature too much/high.
Corrective action:	Reduce pre-heat temperature of external heat source.
Cause:	The need for heat in the system suddenly drops causing hot return water to the boiler.
Corrective action:	Dampen external heating system control to prevent sudden boiler temperature rise.

Display message	T 2 - T 1 h i g h
	9 9 9 , 5 h r s
Reason	Difference between T2 and T1 has exceeded the blocking value which has been set in the parameters.(return temp higher than flow)
Cause:	The water flow through the unit is too low.
Corrective action:	Check functioning of the pump. Check/open all valves that might restrict the water flow through the unit. Check for an external system pump that influences the flow through the unit. Check if the system resistance exceeds the spare capacity of the unit pump. Make sure the heat exchanger is clean. Heat exchanger fouling (partly blockage) will increase the resistance causing the water flow to drop.

Display message	W a t e r p r e s s u r e f a u l t
	9 9 9 , 5 h r s
Reason	Water pressure is too low or high.
Cause:	The water pressure in the system is too high.
Corrective action:	Check if the system pressure is too high after (re)filling. Make sure that there is a pressure relief valve and expansion vessel installed in the system, according to the applicable standards. Check if there is an open connection between the unit and the relief valve plus expansion vessel. Be aware that if the unit is installed in the basement of a tall building, only the static pressure of the water column above the units can raise above the maximum allowable limits. Make sure that this is not the case.
Cause:	The water pressure in the system is too low.
Corrective action:	Check if there is no leakage in the system that causes the pressure to drop. Fix any leakage and fill the system. Check if there is an external system pump that sucks water through the boiler, causing an under pressure. (bad installation design).

16.3 Maintenance attention message

The display shows alternating the base screen and this message, while backlight is blinking. The boiler is operating, but will count the exceeding hours. A parameter must be changed, after service, to remove this message.

Display message	N e e d s M a i n t e n a n	0 . 0
	I g n i t i o n c y c l e s	h r s
Reason	Maintenance option of total amount of ignition cycles has been reached	
Display message	N e e d s M a i n t e n a n	0 . 0
	D a t e	h r s
Reason	Maintenance option of the date has been reached.	
Display message	N e e d s M a i n t e n a n	0 . 0
	B u r n i n g h o u r s	h r s
Reason	Maintenance option of total amount of burning hours has been reached.	
Display message	N e e d s M a i n t e n a n	0 . 0
	A l l	h r s
Reason	One of the abovementioned maintenance options has been reached.	



This function/message is standard not activated, but can be activated/set by a trained engineer. This function does not overrule the need for annual maintenance. The end user is always responsible for arranging annual maintenance.

17 MAINTENANCE

17.1 General

For a good, safe and long-time operation of the boiler it is advised to carry out maintenance and service on the boiler.

Maintenance and inspection of the boiler should be carried out at the following occasions:

- **When several similar error codes and/or lock-outs appear.**
- **At least every 12 months' maintenance must be done to ensure safe and efficient operation.**

Damage caused by lack of maintenance will not be covered under warranty

MAINTENANCE REMINDER FUNCTION.

See *previous page* ←.

BE AWARE: This function is standard turned off. We offer this programmable function to the installer to use as a reminder. Because it concerns a free programmable function the use of it cannot be used as an argument in warranty cases. Our units must be maintained every 12 months whatever the settings/working of this function.

It is and remains the responsibly of the end user to have the unit maintained every twelve months.

For more information about this maintenance mode see chapter 10.14, 'Setting the maintenance specifications'.

Service intervals

The normal service frequency for the boiler is once a year. Every year the boiler should be cleaned and checked, according to the maintenance procedures. If there is doubt whether the boiler is operating with the correct water and/or combustion air quality, it is advised that a first check is executed after already half a year. This check serves to determine the frequency of the future services. The maximum interval between two services is a year.



INSPECTION AND MAINTENANCE MUST BE EXECUTED FOR A SAFE AND EFFICIENT OPERATION OF THE BOILER.

17.2 Inspection & maintenance

At least every twelve months' maintenance must be done to ensure safe and efficient operation.

Inspection, maintenance and the replacement of boiler parts should only be done by a skilled service engineer. Apart from the maintenance proceedings it is advised to have a log chart for every boiler that describes the following aspects:

- Serial number.
- Date and time of maintenance.
- Name of maintenance engineer.
- Which parts were exchanged during maintenance.
- Which settings (software) were changed during maintenance.
- Special remarks / findings.
- Future aspects that need extra attention.
- Additional aspects: measurement reports, complaints by the (end)-user, lock-out codes, etc.

During maintenance the following parts and aspects of the boiler should be checked and inspected.

NOTICE: Before starting to work on the boiler:

- Switch off the electrical power to the boiler (service switch and/or unplug boiler).
- Close the gas valve to block gas supply to the boiler.

Customer comments

Comments and remarks from the customer should be analysed and used to find possible causes for any occurring problems and complaints.

Service history

The operational and fault history (total amount and since the last service) of the boiler can be retrieved with the help of a computer, correct software and an interface cable. This information can be used to specify the maintenance and service proceedings in relation to the boiler(parts).

Water leakage

The water pressure of the heating installation should be more than 1,0 bar and at a maximum of 2,0 bar at normal operation. When the water pressure drops below the minimum occasionally, there might be a water leak. Check the boiler and the complete heating installation for any water leakages and have these repaired.

Flue gas & air supply

The flue gas pipes and the air supply pipes must be checked for gas tightness. Also check if the mounting of these pipes is correct, safe and not damaged. Check the rooftop of the boiler housing for signs of water leakage and traces of water coming from the air supply pipe, the air vent or any condensate coming from the flue gas pipes.

Gas supply & safeties

The gas pipes must be checked for gas tightness. Also check if the mounting of these pipes is correct, safe and not damaged. Any built-in safeties should be checked for a correct functioning.

Remove the burner unit

The burner unit consists of the burner plate, the burner nose and the internal burner. To remove this part for an internal heat exchanger check: remove the six M6 nuts, the nuts that connect the burner nose to the non-return valve and the ignition cable. After this take out the burner unit by moving it forward out of the boiler housing.

NOTICE: watch out not to damage the burner plate insulation during this operation.

Burner

Check the burner surface to see if it has damages, signs of rust and/or cracks. When the burner surface is damaged the burner must be replaced. The burner can be cleaned by using a soft (non-metallic) brush. The dust can be removed with a vacuum cleaner or pressurized air.

Ignition / ionisation electrode

When the complete burner is removed, it is also very easy to check the ignition electrode. First check if the distances between the electrodes and between the electrode and the burner are according to the graph below. When these are not correct, try to bend the electrodes in the right position. Notice: the electrodes undergo high temperatures, therefore the electrodes become hard and are difficult to bend. While bending used electrodes they might break or burst. Check the electrode, after bending, for any tear/crack and signs of rust. When they are burst/cracked or rusty, replace the electrode. Also replace the electrode when there is a crack in the ceramic insulation of the electrode. When the electrode is going to be replaced also the gasket should be renewed.

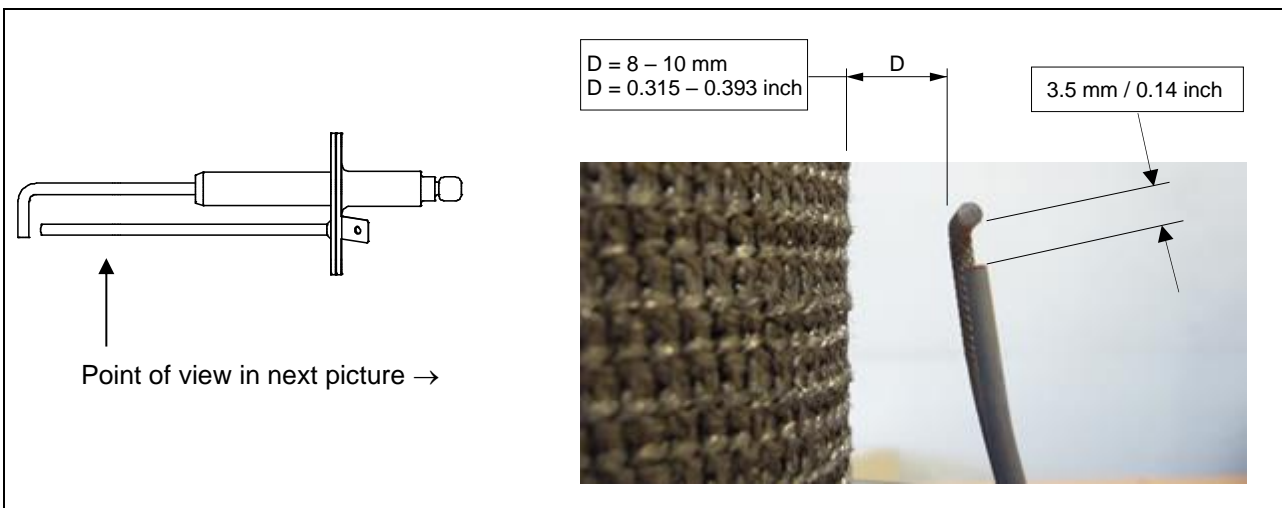

Burner door gaskets

When these gaskets have changed colours at some parts, the rubber has cured and/or is damaged, then these gaskets must be replaced. Notice: only use the gaskets that are supplied by the boiler manufacturer.

Mounting the burner door correctly back onto the heat exchanger:

IMPORTANT:

Before mounting the burner door, make sure that its gaskets and insulation are in excellent shape. If any signs of damage or ageing are present, these parts must be replaced.

The burner door must be mounted back on the heat exchanger as follows, see picture below:

- Place the burner door with its holes over the six threaded studs, numbered 1 to 6 in the picture.
- Careful! When handling too rough or misplacing the holes over the threaded studs, the burner door insulation and/or gaskets may be damaged.* Assure yourself that the door is well positioned with respect to the threaded studs, before pushing it onto the exchanger.
- Now keep the burner door in place and first turn one flange nut onto stud 1 so the door won't fall. After that, first mount the other end of the gas/air mixing pipe to the non-return valve, starting at point I, and make sure it's well tightened.
 - Now keep the burner door firmly in place by pushing the gas/air nose with one hand at the middle at point A.
 - Then turn-tighten the flange nuts with the other hand as far as possible onto the threaded studs.

Now the burner door is in place and the nuts can be tightened with a torque key.

- Tighten the nuts in the order given in the picture below
- The specified torque value for tightening the burner door flange nuts is 8 Nm

tighten in given order.

torque value = 8 Nm

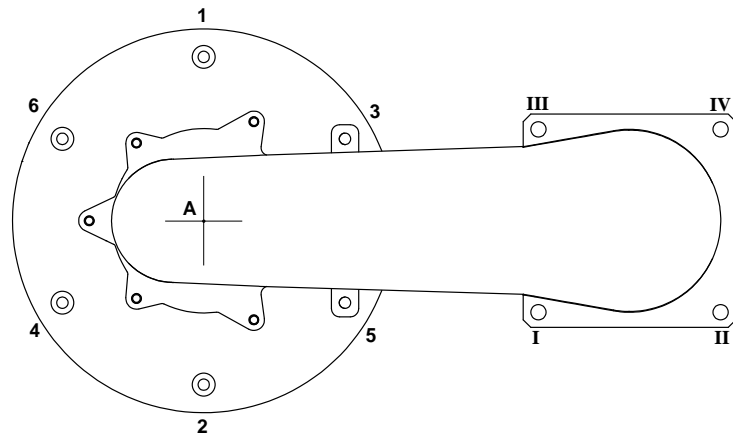

Non-return valve

Remove the non-return valve from the fan by loosening the nuts and remove the wiring by disconnecting the connector. Check if there is any moist or any traces of moist on the fan side of the valve. This can indicate that there is a possible leakage of the non-return valve (danger of recirculation).

Check always if the rubber seat on which the valve closes isn't damaged or if there is any debris on this seat, if so clean or replace the seat. Also check if the valve itself isn't jammed and can move freely up and down and if the magnet pulls the valve into its seat, if not so replace the complete non-return valve.

Fan

When the fan blades are polluted and dirty, carefully clean the blades with a soft brush. Notice: do not use too much force on the blades or else the fan might be out of balance and run irregularly, causing noises and fan failures. Check the fan also for any water damages. In doubt always replace the fan of the boiler.

Insulation

The insulation of the heat exchanger (located on the rear wall inside the heat exchanger and burner door) must be inspected. If this insulation disk shows any signs of (water) damage or degradation it should be exchanged. Also check if there are any indications in the burner room of a high condensate level (caused by a blocked siphon) that might have wetted the rear wall insulation. When this has happened the rear wall insulation should also be replaced. Only use the insulation disk that is supplied by the boiler manufacturer.

The same procedure must be applied on the insulation and gaskets fitted on the burner door.

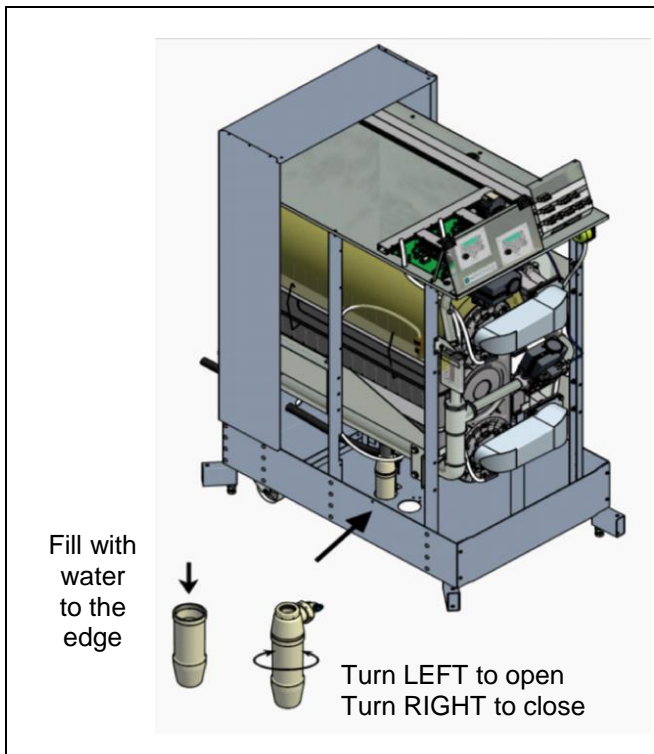

Siphon

Disassemble the siphon and clean every part of it. Check the siphon connection of the heat exchanger for any blocking or pollution and clean it (if necessary). Check the functioning of the siphon by pouring clean tap water in the burner room (when burner door is removed). This water will exit the heat exchanger by the siphon. Notice: don't wet the rear wall insulation.



Do **NOT** operate the unit without mounted and completely filled siphon reservoir.

This is a safety measure: the water in the siphon keeps the flue gases from entering the plant room via the condensate drain.

Heat exchanger and burner room

After the removal of the complete burner unit, check if there is any debris and dirt in the heat exchanger. The coils of the heat exchanger can be cleaned by using a non-metallic brush. After this the dirt and dust can be removed with a vacuum cleaner and by flushing the burner room with water. Don't forget afterwards to clean the siphon once again.



Cleaning the burner room with acid or alkali products is prohibited.

Gas/air ratio

With every service check and/or maintenance of the boiler always check the gas/air ratio by measuring the CO₂ percentage (flue gas) at the maximum and minimum load of the boiler. If necessary adjust these values, see for information chapter 14 "Adjusting and setting the burner".

Pump

Check the electrical parts and the motor of the pump for a correct functioning. The pump must generate a sufficient water flow over the (heat exchanger of) the boiler. When the pump produces noise, is operational for more than 5 years or has signs of water leakage it is recommended to replace the pump as a precaution.



When defects and abnormalities are found by the service engineer during service and maintenance and these are not repairable, this information should be reported to the owner/end-user of the installation. Also, the owner/end-user should be advised how to fix these defects and these defects should be reported in the service report / log file of the boiler.



During service and maintenance, the gas, supply air, flue gas and condensate connections are disconnected, checked and replaced. Make sure that all these components are mounted correctly before commissioning the boiler again.

18 USER INSTRUCTIONS

After installing and commissioning of the boiler demonstrate the operation of the entire central heating system to the end-user. The user should be made familiar with all safety precautions of the boiler and the installation. The user should be instructed that service and maintenance of the boiler is required every 12 months. Regular service and maintenance is essential for a safe and proper operation of the boiler. Hand over the documents that are supplied with the boiler.

19 Examples of installations

The following drawings are presenting possible ways for installing the boiler.

SYSTEM 1

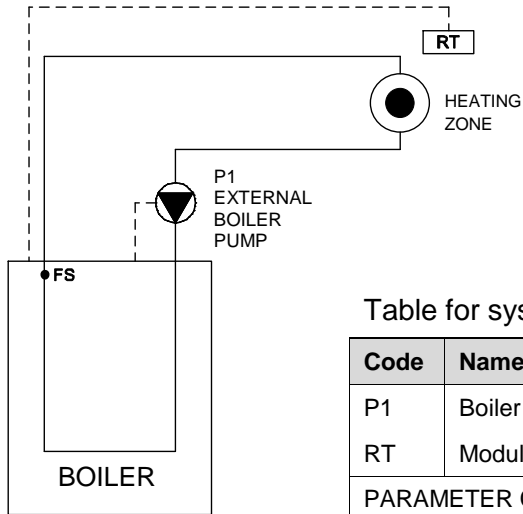

Table for system 1:

Code	Name	Wire terminal	Part nr.
P1	Boiler pump	Relay pump1	
RT	Modulating room unit with timer	13-14	S04.016.355
PARAMETER CHANGE: NO			

SYSTEM 2

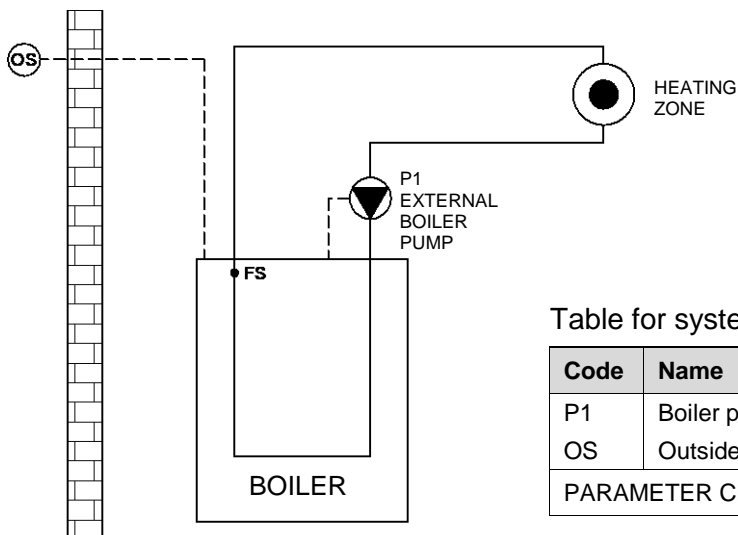

Table for system 2:

Code	Name	Wire terminal	Part nr.
P1	Boiler pump	Relay pump1	
OS	Outside temperature sensor	01-02	
PARAMETER CHANGE: NO			

SYSTEM 3

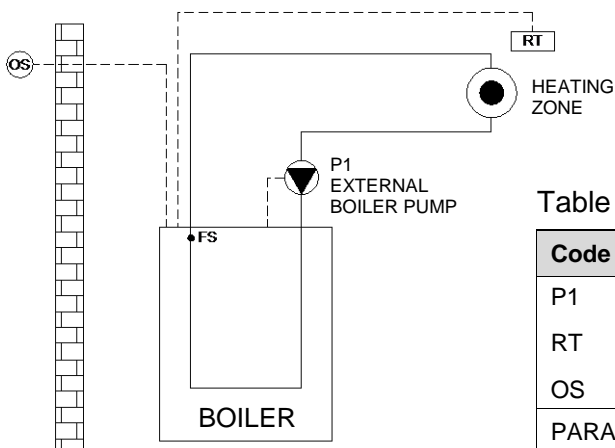

Table for system 3:

Code	Name	Wire terminal	Part nr.
P1	Boiler pump	Relay pump1	
RT	Modulating room unit with timer	13-14	
OS	Outside temperature sensor	01-02	E04.016.585
PARAMETER CHANGE: NO			

SYSTEM 4

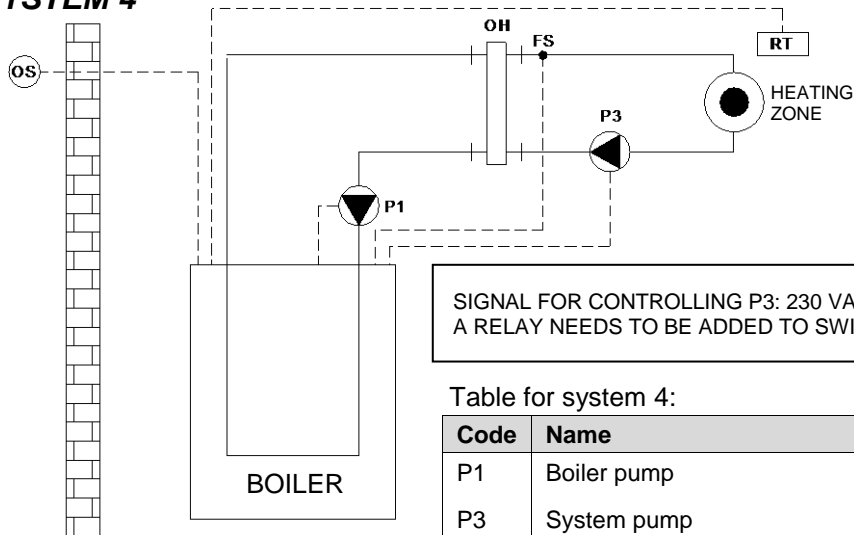

Table for system 4:

Code	Name	Wire terminal	Part nr.
P1	Boiler pump	Relay pump1	
P3	System pump	34-36 (230 Vac control signal)	
OH	Low loss header	-	
RT	Modulating room unit with timer	13-14	
OS	Outside temperature sensor		E04.016.585
FS	External flow sensor	03-04	E04.016.304
PARAMETER CHANGE: NO			

SYSTEM 5

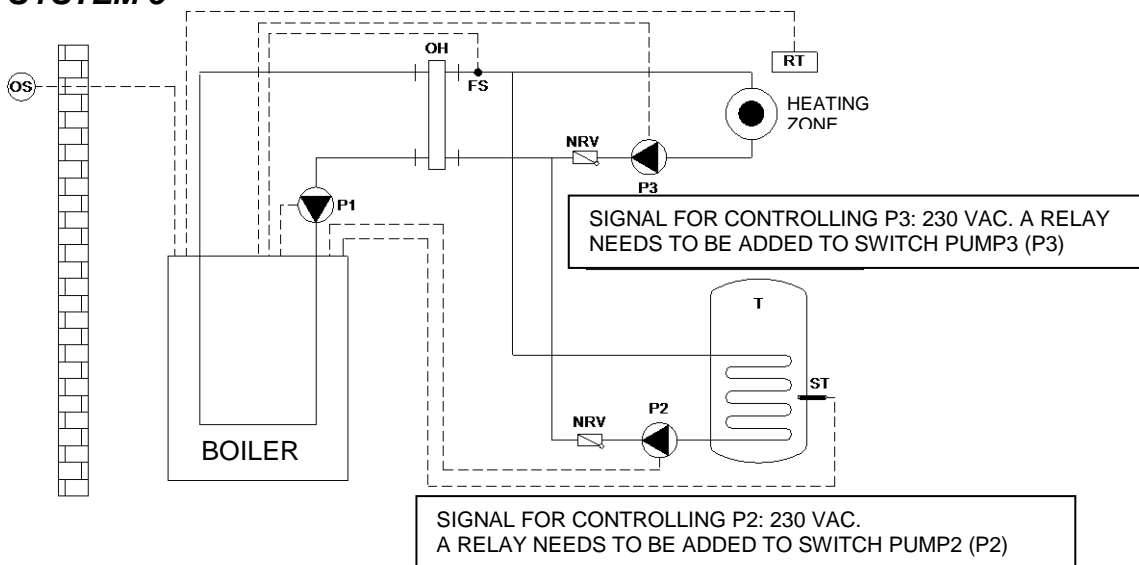
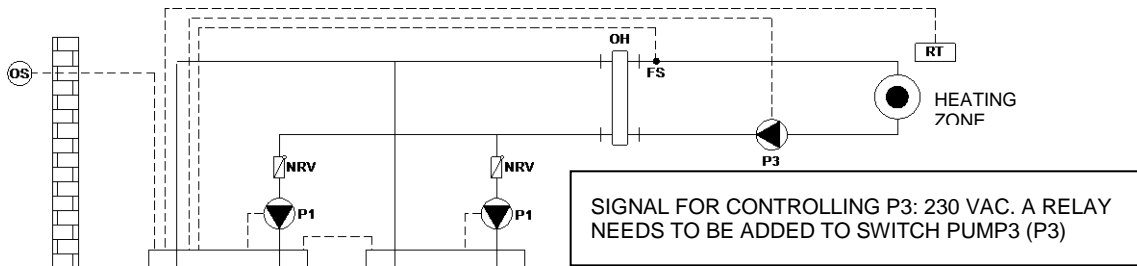

Table for system 5

Code	Name	Wire terminal	Part nr.
P1	Boiler pump	Relay pump1	
P2	Calorifier primary pump	38-40 (230 Vac control signal)	
P3	System pump	34-36 (230 Vac control signal)	
OH	Low loss header	-	
T	Calorifier	-	
NRV	Non-return valve	-	
RT	Modulating room unit with timer	13-14	
OS	Outside temperature sensor	01-02	E04.016.585
FS	External flow sensor	03-04	E04.016.304
ST	Tank sensor	05-06	E400277
PARAMETER CHANGE: NO			

SYSTEM 6



Code	Name	Wire terminal	Part nr.
P1	Boiler pump	Relay pump1	
P3	System pump	34-36 (230 Vac control signal)	
OH	Low loss header	-	
NRV	Non-return valve	-	
RT	Modulating room unit with timer	13-14	
OS	Outside temperature sensor	01-02	E04.016.585
FS	External flow sensor	03-04	E04.016.304
PARAMETER CHANGE: YES			

SYSTEM 7

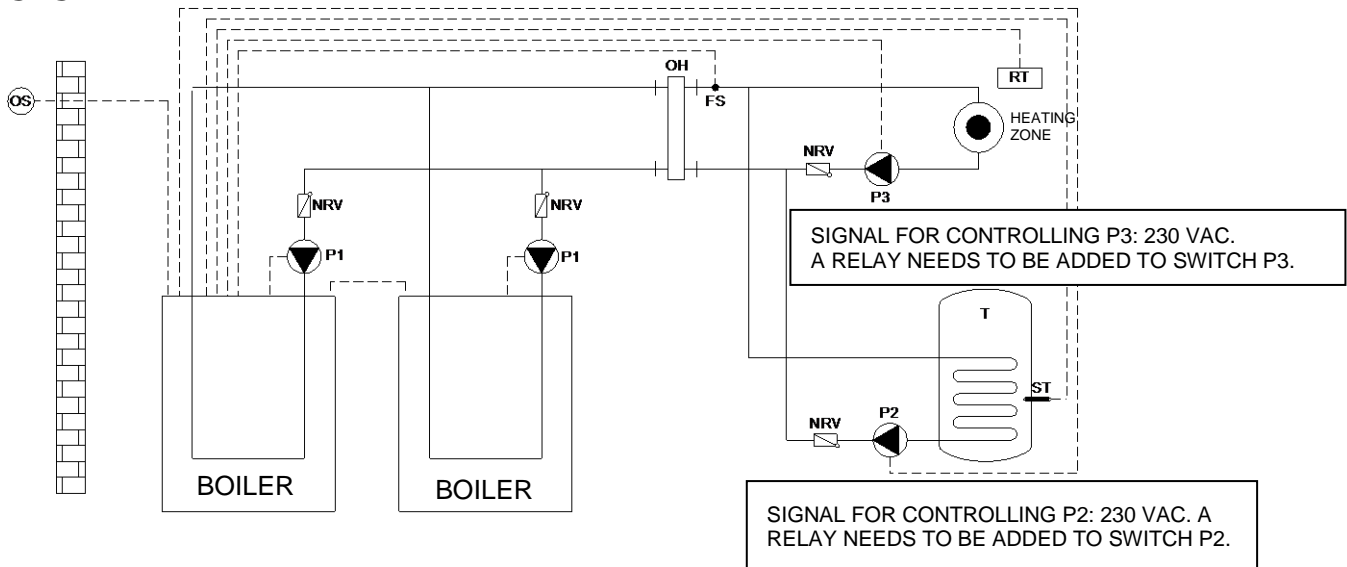

Table for system 7

Code	Name	Wire terminal	Part nr.
P1	Boiler pump	Relay pump1	
P2	Calorifier primary pump	38-40 (230 Vac cont. signal)	
P3	System pump	34-36 (230 Vac cont. signal)	
OH	Low loss header	-	
T	Calorifier	-	
NRV	Non-return valve	-	
RT	Modulating room unit with timer	13-14	
OS	Outside temperature sensor	01-02	E04.016.585
FS	External flow sensor	03-04	E04.016.304
ST	Tank sensor	05-06	E400277
PARAMETER CHANGE: YES			

Strebel Ltd

Unit 10, Invincible Industrial Estate,
Invincible Road, Farnborough,
Hampshire, GU14 7QU.

T 01276 685422
F 01276 685405
E info@strebel.co.uk
I www.strebel.co.uk



Further information on our complete product range is available from our website.

CAST IRON – CONDENSING – STEEL SHELL – WATER HEATERS – RENEWABLES
FLUES – ACCESSORIES.

