

Installation, Operating and Service Instructions for

ALPINE

- Condensing
- Direct Vent
- Gas Fired

Alpine “C” Models:

- ALP399C
- ALP500C
- ALP600C
- ALP700C
- ALP800C



<u>Manual Contents</u>	<u>Page</u>
1. Product Description, Specifications & Dimensional Data	4
2. Unpacking Boiler	8
3. Pre-installation & Boiler Mounting	9
4. Venting	14
5. Condensate Disposal	39
6. Water Piping & Trim	41
7. Gas Piping	53
8. Electrical	58
9. System Start-up	69
10. Operation	78
11. Service & Maintenance	108
12. Troubleshooting	115
13. Service Parts	121
Appendix	
A. Instructions for High Altitude Installation	134
B. Figures	137
C. Tables	140

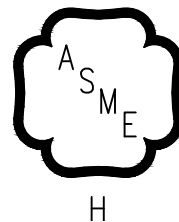

WARNING

This boiler must only be installed, serviced, or repaired by a qualified heating installer or service technician. Improper installation, adjustment, alteration, service or maintenance can cause severe personal injury, death, or substantial property damage. For assistance or additional information, consult a qualified installer, service agency, or the gas supplier. Read these instructions carefully before installing.



IMPORTANT INFORMATION - READ CAREFULLY

NOTE: The equipment shall be installed in accordance with those installation regulations enforced in the area where the installation is to be made. These regulations shall be carefully followed in all cases. Authorities having jurisdiction shall be consulted before installations are made.

All wiring on boilers installed in the USA shall be made in accordance with the *National Electrical Code* and/or local regulations.

All wiring on boilers installed in Canada shall be made in accordance with the *Canadian Electrical Code* and/or local regulations.

The following terms are used throughout this manual to bring attention to the presence of hazards of various risk levels, or to important information concerning product life.

 DANGER

Indicates a hazardous situation that, if not avoided, will result in death or serious injury.

 CAUTION

Indicates a hazardous situation that, if not avoided, could result in minor or moderate injury.

 WARNING

Indicates a hazardous situation that, if not avoided, could result in death or serious injury.

NOTICE: Indicates special instructions on installation, operation, or service which are important but not related to personal injury hazards.

 WARNING

Explosion Hazard. DO NOT store or use gasoline or other flammable vapors or liquids in the vicinity of this or any other appliance.

If you smell gas vapors, DO NOT try to operate any appliance - DO NOT touch any electrical switch or use any phone in the building. Immediately, call the gas supplier from a remotely located phone. Follow the gas supplier's instructions or if the supplier is unavailable, contact the fire department.

Special Installation Requirements for Massachusetts

- A. For all sidewall horizontally vented gas fueled equipment installed in every dwelling, building or structure used in whole or in part for residential purposes and where the sidewall exhaust vent termination is less than seven (7) feet above grade, the following requirements shall be satisfied:
1. If there is no carbon monoxide detector with an alarm already installed in compliance with the most current edition of NFPA 720, NFPA 70 and the Massachusetts State Building Code in the residential unit served by the sidewall horizontally vented gas fueled equipment, a battery operated carbon monoxide detector with an alarm shall be installed in compliance with the most current edition of NFPA 720, NFPA 70 and the Massachusetts State Building Code.
 2. In addition to the above requirements, if there is not one already present, a carbon monoxide detector with an alarm and a battery back-up shall be installed and located in accordance with the installation requirements supplied with the detector on the floor level where the gas equipment is installed. The carbon monoxide detector with an alarm shall comply with 527 CMR, ANSI/UL 2034 Standards or CSA 6.19 and the most current edition of NFPA 720. In the event that the requirements of this subdivision can not be met at the time of the completion of the installation of the equipment, the installer shall have a period of thirty (30) days to comply with this requirement; provided, however, that during said thirty (30) day period, a battery operated carbon monoxide detector with an alarm shall be installed in compliance with the most current edition of NFPA 720, NFPA 70 and the Massachusetts State Building Code. In the event that the sidewall horizontally vented gas fueled equipment is installed in a crawl space or an attic, the carbon monoxide detector may be installed on the next adjacent habitable floor level. Such detector may be a battery operated carbon monoxide detector with an alarm and shall be installed in compliance with the most current edition of NFPA 720, NFPA 70 and the Massachusetts State Building Code.
 3. A metal or plastic identification plate shall be permanently mounted to the exterior of the building at a minimum height of eight (8) feet above grade directly in line with the exhaust vent terminal for the horizontally vented gas fueled heating appliance or equipment. The sign shall read, in print size no less than one-half (1/2) inch in size, **“GAS VENT DIRECTLY BELOW. KEEP CLEAR OF ALL OBSTRUCTIONS”**.
 4. A final inspection by the state or local gas inspector of the sidewall horizontally vented equipment shall not be performed until proof is provided that the state or local electrical inspector having jurisdiction has granted a permit for installation of carbon monoxide detectors and alarms as required above.
- B. EXEMPTIONS: The following equipment is exempt from 248 CMR 5.08(2)(a) 1 through 4:
1. The equipment listed in Chapter 10 entitled “Equipment Not Required To Be Vented” in the most current edition of NFPA 54 as adopted by the Board; and
 2. Product Approved sidewall horizontally vented gas fueled equipment installed in a room or structure separate from the dwelling, building or structure used in whole or in part for residential purposes.
- C. When the manufacturer of Product Approved sidewall horizontally vented gas equipment provides a venting system design or venting system components with the equipment, the instructions for installation of the equipment and the venting system shall include:
1. A complete parts list for the venting system design or venting system; and
 2. Detailed instructions for the installation of the venting system design or the venting system components.
- D. When the manufacturer of a Product Approved sidewall horizontally vented gas fueled equipment does not provide the parts for venting flue gases, but identifies “special venting systems”, the following shall be satisfied:
1. The referenced “special venting system” instructions shall be included with the appliance or equipment installation instructions; and
 2. The “special venting systems” shall be Product Approved by the Board, and the instructions for that system shall include a parts list and detailed installation instructions.
- E. A copy of all installation instructions for all Product Approved sidewall horizontally vented gas fueled equipment, all venting instructions, all parts lists for venting instructions, and/or all venting design instructions shall remain with the appliance or equipment at the completion of the installation.

1 Product Description, Specifications and Dimensional Data

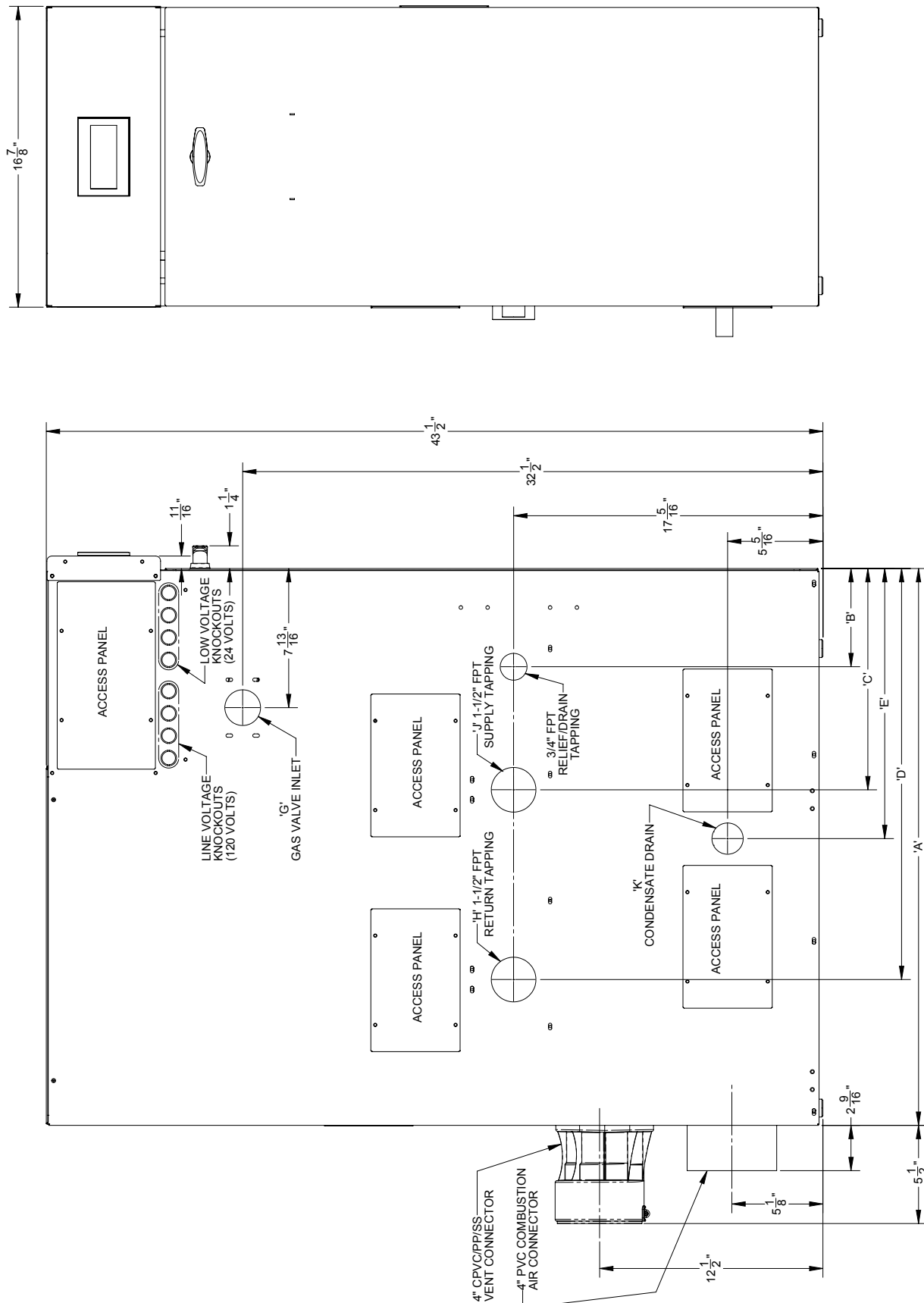

Figure 1-1: Alpine - Model ALP399C

1 Product Description, Specifications and Dimensional Data *(continued)*

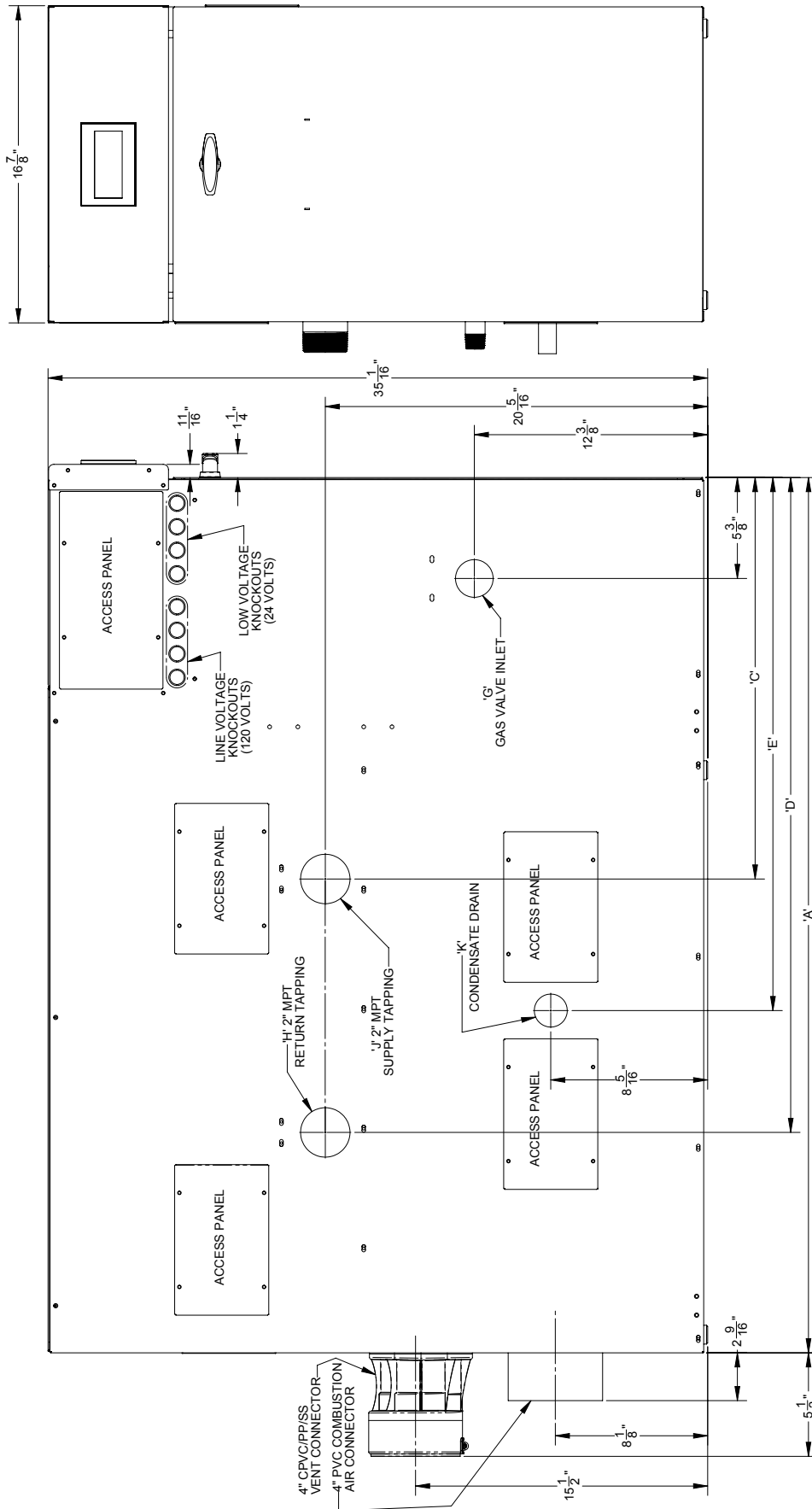

Figure 1-2: Alpine - Model ALP500C

1 Product Description, Specifications and Dimensional Data *(continued)*

Table 1-4: Ratings

Alpine Series Gas-Fired Boilers



Model Number	Input (MBH)		Gross Output (MBH)	Net Ratings Water ¹ (MBH)	Thermal Efficiency (%)	Combustion Efficiency (%)
	Min.	Max.				
ALP399C	80	399	375	326	94.1	94.5
ALP500C	100	500	485	422	97.0	96.0
ALP600C	125	625	594	517	95.0	96.0
ALP700C	145	725	689	599	95.0	95.0
ALP800C	160	800	760	661	95.0	94.0

Ratings shown are for installations at sea level and elevations up to 2,000 ft. at minimum vent length. For elevations above 2,000 ft., see Appendix A Instructions for High Altitude Installations above 2,000 ft.

¹ Net AHRI Water Ratings based on allowance of 1.15. Consult manufacturer before selecting boiler for installations having unusual piping and pickup requirements, such as intermittent system operation, extensive piping systems, etc.

Table 1-5: Specifications

Specification	Boiler Model				
	ALP399C	ALP500C	ALP600C	ALP700C	ALP800C
Altitude (ft. above sea level) ¹	0-10,100	0-10,100 ²	0-10,100	0-10,100 ³	0-6,000 ⁴
Fuel	Shipped for Natural Gas, Field Converted for LP Gas		Shipped for Natural Gas or Shipped for LP Gas (no Field Conversion)		
Max. Allowable Water Temperature (°F)	210	210	210	210	210
Max. Allowable Working Pressure (psi)	160	160	160	160	160
Factory Supplied Safety Relief Valve (psi)*	50	50	60	60	60
Boiler Water Volume (gal.)	3.4	4.3	5.4	5.4	6.2
Heat Transfer Area (sq. ft.)	41.8	58.1	76.2	76.2	87.0
Approx. Shipping Weight (lb.)	316	368	458	458	500

* Optional 80 psi and 100 psi safety relief valves are available for all models.

¹ Follow Instructions for High Altitude Installations above 2,000 ft. (see Appendix A)

² ALP500C LP cannot be installed above 6,000 ft.

³ ALP700C LP cannot be installed above 7,800 ft.

⁴ ALP800C natural gas cannot be installed above 6,000 ft. ALP800C LP can be installed up to 10,100 ft.

Table 1-6: Dimensions (See Figures 1-1 through 1-3)

Dimension	Boiler Model				
	ALP399C	ALP500C	ALP600C	ALP700C	ALP800C
A - Inch (mm)	31-3/16 (792)	46-1/2 (1181)	49-1/2 (1258)	49-1/2 (1258)	53-5/16 (1258)
B - Inch (mm)	5-1/2 (140)	N/A	N/A	N/A	N/A
C - Inch (mm)	12-3/8 (314)	21-5/16 (541)	23-1/4 (591)	23-1/4 (591)	23-7/16 (596)
D - Inch (mm)	23 (584)	34-13/16 (884)	38-1/16 (967)	38-1/16 (967)	41-3/16 (1046)
E - Inch (mm)	15-1/8 (384)	28-5/16 (719)	30-7/8 (784)	30-7/8 (784)	32-9/16 (827)
Gas Inlet G - Inch	3/4 (FPT)		1 (FPT)		
Return H - Inch	1-1/2 FPT	2 MPT			
Supply J - Inch	1-1/2 FPT	2 MPT			
PP Condensate Drain K - Inch	3/4 PVC Compression Coupling				
PVC Combustion Air Connector - Inch	4				
CPVC/PP/SS Vent Connector - Inch (mm)	4 (100)		6 (150)		

1 Product Description, Specifications and Dimensional Data *(continued)*

Alpine Series boilers are condensing, high efficiency, gas-fired, direct vent, hot water boilers designed for use in forced hot water space or space heating with indirect domestic hot water heating systems, where supply water temperature does not exceed 210°F. These boilers have special coil type stainless steel

heat exchangers, constructed, tested and stamped per Section IV 'Heating Boilers' of ASME Boiler and Pressure Vessel Code, which provide a maximum heat transfer and simultaneous protection against flue gas product corrosion. These boilers are not designed for use in gravity hot water space heating systems or systems containing significant amount of dissolved oxygen (swimming pool water heating, direct domestic hot water heating, etc.).

2 Unpacking Boiler

NOTICE: Do not drop boiler.

- A. Move boiler to approximate installed position.
- B. Remove all crate fasteners.
- C. Lift and remove outside container.
- D. Remove boiler from cardboard positioning sleeve on shipping skid.
- E. Move boiler to its permanent location.

3 Pre-installation and Boiler Mounting

⚠ WARNING

Explosion Hazard. Asphyxiation Hazard. Electrical Shock Hazard. Installation of this boiler should be undertaken only by trained and skilled personnel from a qualified service agency. Follow these instructions exactly. Improper installation, adjustment, service, or maintenance can cause property damage, personal injury or death.

NOTICE: Due to the low water content of the boiler, mis-sizing of the boiler with regard to the heating system load will result in excessive boiler cycling and accelerated component failure. U.S. Boiler Company DOES NOT warrant failures caused by mis-sized boiler applications. DO NOT oversize the boiler to the system. Multiple boiler installations greatly reduce the likelihood of boiler oversizing.

⚠ WARNING

Asphyxiation Hazard. Apply supplied dielectric grease to gasket inside vent connector. Failure to apply the grease could result in flue gas leaks from gasket rupture during vent pipe installation or gasket deterioration due to condensate exposure.

A. Installation must conform to the requirements of the authority having jurisdiction in or, in the absence of such requirements, to the *National Fuel Gas Code*, ANSI Z223.1/NFPA 54, and/or *Natural Gas and Propane Installation Code*, CAN/CSA B149.1.

Where required by the authority having jurisdiction, the installation must conform to the *Standard for Controls and Safety Devices for Automatically Fired Boilers*, ANSI/ASME CSD-1.

B. Boiler is certified for installation on combustible flooring. Do not install boiler on carpeting.

C. Provide clearance between boiler jacket and combustible material in accordance with local fire ordinance. Refer to Figure 3-3 for minimum listed clearances from combustible material. Recommended service clearance is 24 in. (610 mm) from left side, front, top and rear of the boiler. Recommended front clearance may be reduced to the combustible material clearance providing:

1. Access to boiler front is provided through a door or removable front access panel.

2. Access is provided to the condensate trap located underneath the heat exchanger.
3. Access is provided to thermal link located at boiler rear.

D. Protect gas ignition system components from water (dripping, spraying, rain, etc.) during boiler operation and service (circulator replacement, condensate trap, control replacement, etc.).

E. Provide combustion and ventilation air in accordance with applicable provisions of local building codes, or: USA - *National Fuel Gas Code*, ANSI Z223.1/NFPA 54, Air for Combustion and Ventilation;
Canada - *Natural Gas and Propane Installation Code*, CAN/CSA-B149.1, Venting Systems and Air Supply for Appliances.

Table 3-1: Corrosive Combustion Air Contaminants and Sources

Contaminants to avoid:
Spray cans containing chloro/fluorocarbons (CFC's)
Permanent wave solutions
Chlorinated waxes/cleaners
Chlorine-based swimming pool chemicals
Calcium chloride used for thawing
Sodium chloride used for water softening
Refrigerant leaks
Paint or varnish removers
Hydrochloric acid/muriatic acid
Cements and glues
Antistatic fabric softeners used in clothes dryers
Chlorine-type bleaches, detergents, and cleaning solvents found in household laundry rooms.
Adhesives used to fasten building products and other similar products
Excessive dust and dirt
Areas likely to have contaminants:
Dry cleaning/laundry areas and establishments
Swimming pools
Metal fabrication plants
Beauty shops
Refrigeration repair shops
Photo processing plants
Auto body shops
Plastic manufacturing plants
Furniture refinishing areas and establishments
New building construction
Remodeling areas
Garages with workshops

3 Pre-installation and Boiler Mounting *(continued)*

WARNING

Asphyxiation Hazard. Adequate combustion and ventilation air must be provided to assure proper combustion. Install combustion air intake per Section 4 “Venting”.

F. The boiler should be located so as to minimize the length of the vent system. Locate combustion air pipe termination away from areas that may contaminate combustion air, (see Table 3-1). In particular, avoid areas near chemical products containing chlorines, chlorofluorocarbons, paint removers, cleaning solvents and detergents. Avoid areas containing saw dust, loose insulation fibers, dry wall dust, etc.

NOTICE: Avoid operating this boiler in an environment where sawdust, loose insulation fibers, dry wall dust, etc. are present. If boiler is operated under these conditions, the burner interior and ports must be cleaned and inspected daily to ensure proper operation.

G. General.

- Alpine boilers are intended for installations in an area with a floor drain, or in a suitable drain pan to prevent any leaks or safety relief valve discharge resulting in property damage.
- Alpine boilers are not intended to support external piping and venting. All external piping and venting must be supported independently of the boiler.
- Alpine boilers must be installed level to prevent condensate from backing up inside the boiler.
- Boiler Installation:
 - For basement installation provide a solid level base such as concrete where floor is not level or where water may be encountered on the floor around boiler.

Floor must be able to support weight of boiler, water and all additional system components.

- Boiler must be level to prevent condensate from backing up inside the boiler.
- Provide adequate space for condensate piping or a condensate pump if required.

Boiler Clearances to Combustible (and Non-Combustible) Material:

Models ALP399C and ALP500C:

These boilers are listed for closet installation with the following minimum clearances – Top = 1 in. (25 mm), Front = 1 in. (25 mm), Left Side = 10 in. (250 mm), Right Side = 2 in. (50 mm), Rear = *6 in. (150 mm)

Models ALP600C, ALP700C and ALP800C:

These boilers are listed for alcove installation with the following minimum clearances – Top = 1 in. (25 mm), Front = Open, Left Side = 10 in. (250 mm), Right Side = 2 in. (50 mm), Rear = *6 in. (150 mm).

Note:

When boiler is vented vertically, the minimum clearance from the rear of the jacket is increased to 18 in. (460 mm) with a short radius 90° elbow provided in order to provide adequate space at boiler rear for installation of vent and air intake piping and service access.

Boiler Service Clearances – Applicable to all Boiler Models:

Top = 24 in. (610 mm), Front = 24 in. (610 mm), Left Side = 24 in. (610 mm), Right Side = 24 in. (610 mm), Rear = 24 in. (610 mm)

The above clearances are recommended for service access but may be reduced to the Combustible Material Clearances provided:

- The boiler front is accessible through a door.
- Access is provided to the condensate trap located on the left side of boiler.
- Access is provided to thermal link located at the boiler rear.

Table 3-2: Vent Pipe Clearances to Combustible Material

Listed Direct Vent System	Vent Pipe Material	Vent Pipe Direction	Enclosure	Vent Pipe Nominal Diameter	Minimum Clearance to Combustible Material
<u>Standard</u> Two-Pipe CPVC/PVC Vent and PVC Combustion Air Intake	CPVC/PVC	Vertical or Horizontal	Unenclosed at all Sides	3 in. (80 mm), 4 in. (100 mm or 110 mm), 6 in. (150 mm or 160 mm)	1 in. (25 mm)
<u>Optional</u> Two-Pipe Rigid Polypropylene Vent (or, Flexible Polypropylene Liner for Vertical Venting only) and Rigid Polypropylene or PVC Combustion Air Intake	Rigid Polypropylene (or, Flexible Polypropylene Liner for Vertical Venting only)			3 in. (80 mm), 4 in. (100 mm or 110 mm), 6 in. (150 mm or 160 mm)	1 in. (25 mm)
<u>Optional</u> Two-Pipe Stainless Steel Vent and Galvanized Steel or PVC Combustion Air Intake	Stainless Steel			3 in. (80 mm), 4 in. (100 mm or 110 mm), 6 in. (150 mm or 160 mm)	1 in. (25 mm)

3 Pre-installation and Boiler Mounting *(continued)*

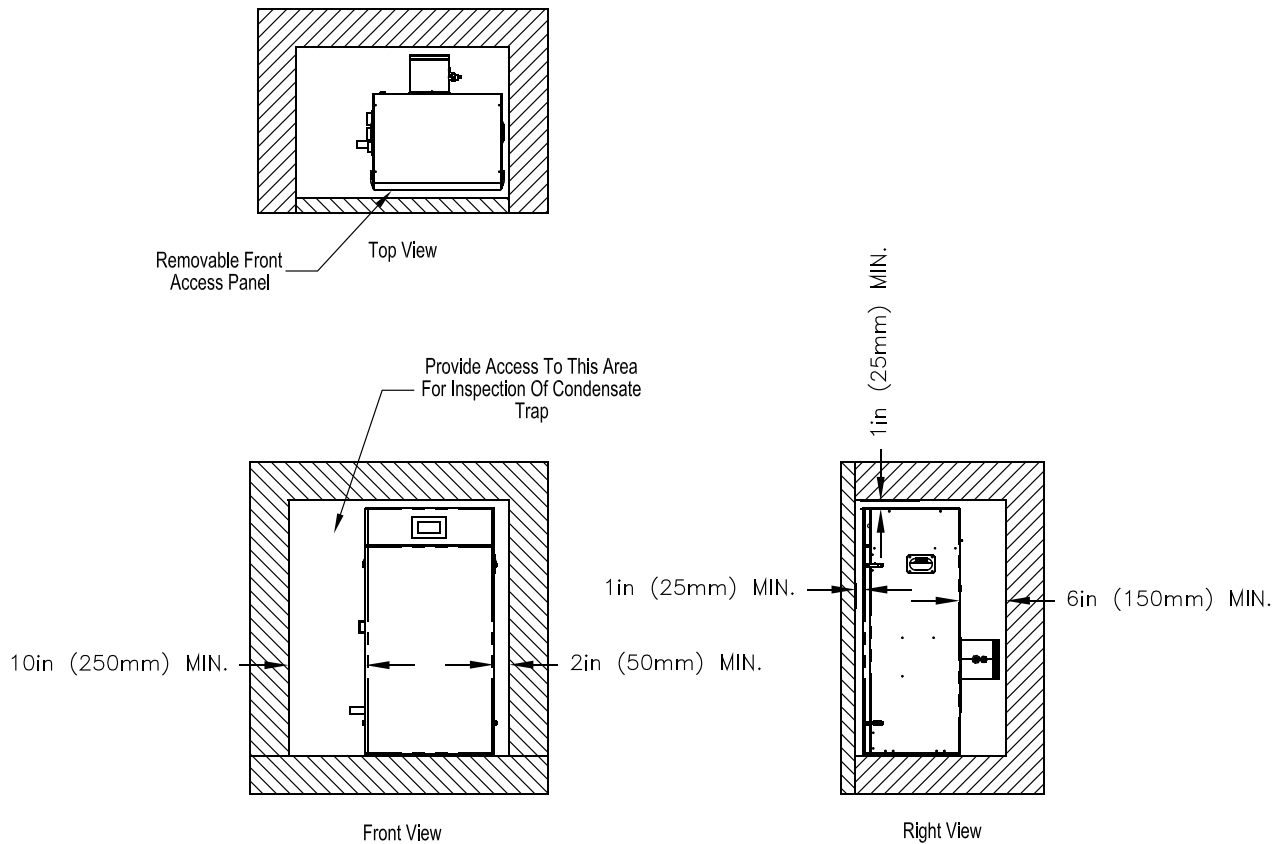

Figure 3-3: Clearances to Combustible and Non-combustible Material

H. Boiler Stacking

1. For installations with unusually high space heating and/or domestic hot water heating loads, where employing multiple boilers will offer the benefits of greater operational efficiency, floor space savings and boiler redundancy, boilers may be installed stacked maximum one boiler on top of another. Refer to Table 3-4 “Alpine Boiler Model Stacking Combinations” for details.

Table 3-4: Alpine Boiler Model Stacking Combinations

Bottom Boiler Model	Top Boiler Model
ALP399C	ALP399C
ALP500C	ALP399C or ALP500C
ALP600C	ALP399C, ALP500C or ALP600C
ALP700C	ALP399C, ALP500C, ALP600C or ALP700C
ALP800C	ALP399C, ALP500C, ALP600C, ALP700C or ALP800C

2. To field assemble individual Alpine boilers into a stackable configuration, use the steps below:
 - a. Position the bottom boiler first. Refer to Sections 2 “Unpacking Boiler” and 3 “Pre-Installation & Boiler Mounting” of the manual for details. **Always position higher input boiler model as bottom boiler.**

- b. Each Alpine boiler is factory packaged with 2 stacking boiler attachment brackets (P/N 101679-01) and the bracket mounting hardware [six (6) self-drilling hex washer head plated #8 x ½ in. long screws, P/N 80860743]. Locate and remove the brackets and the hardware. The stacking boiler attachment bracket has three 7/32 in. diameter holes punched in a triangular pattern. See Figure 3-5 “Boiler Stacking”.
- c. Alpine boiler left and right side panels have a series of dimples at panel top and bottom. These dimples are positioning dimples for stacking boiler attachment bracket mounting screws. Side panel bottom positioning dimples are evenly spaced from boiler front and back, while side panel top positioning dimples follow specific pattern to compensate for Alpine boiler model variable depth.
- d. Position the upper boiler on top of the bottom boiler aligning boiler front doors and sides flush with each other.

3 Pre-installation and Boiler Mounting *(continued)*

- Place first stacking boiler attachment bracket onto the upper boiler left side panel, at the panel lower left corner and align bracket two upper holes with corresponding side panel lower dimples.
 - The remaining lower bracket hole must align with a matching bottom boiler left side panel top positioning dimple.
 - Once bracket holes and side panel dimple alignment is verified, attach the bracket to top and bottom boiler left side panels with the mounting screws.
- e. Repeat above procedure to install second stacking boiler attachment bracket and secure the stacked boiler right side panels together at the front right corner.
 - f. Install the third stacking boiler attachment bracket to secure top and bottom boiler left side panels at the rear left corner. Align the bracket holes with corresponding positioning dimples in the top boiler and bottom boiler left side panels, then secure bracket with the screws.
 - g. Repeat above procedure to install the fourth stacking boiler attachment bracket to secure stacked boiler right side panels at the rear right corner.

3. When installing stackable boiler

combinations observe the following guidelines:

- a. Venting - Top and bottom boilers must have their individual vent piping and vent terminals.

Follow instructions in Section 4 “Venting” of the manual for specifics of individual boiler vent termination. Follow instructions in Section 5 “Condensate Disposal” for each individual boiler flue gas condensate line construction and condensate disposal. Terminating individual boiler condensate lines into common pipe prior to drain disposal is permissible, provided common pipe has sufficient flow capacity to handle combined condensate volume of stackable combination.

- b. Gas Piping - Follow instructions in Section 7 “Gas Piping” of the manual for sizing and installation of an individual boiler. When common gas piping is sized, ensure it will have adequate capacity for combined input (CFH gas flow) of the selected stackable boiler combination.
- c. Water Piping and Trim - Follow instructions in Section 6 “Water Piping and Trim” of the manual for system piping and boiler secondary piping selection/sizing based on combined heating capacity and/or gross output of the selected stackable boiler combination. Follow instructions of Section 6 “Water Piping and Trim” for each individual boiler trim installation.
- d. Electrical - Follow instructions in Section 8 “Electrical” of the manual to wire individual boilers.

WARNING

Asphyxiation Hazard. No common manifold venting is permitted. Each boiler must have its own individual vent and combustion air pipes and terminals.

For sidewall venting individual model vent terminals must terminate no closer than 12 in. (300 mm) horizontally and 3 ft. (900 mm) vertically from each other in order to prevent combustion air contamination. For vertical through the roof venting, individual vertical vent terminals, if level with each other, must be spaced no closer than 12 in. (300 mm) horizontally. If vertical terminals cannot end in one plane, they must be spaced no closer than 3 ft. (900 mm) horizontally.

3 Pre-installation and Boiler Mounting *(continued)*

Dimple used on
other stacking
options.

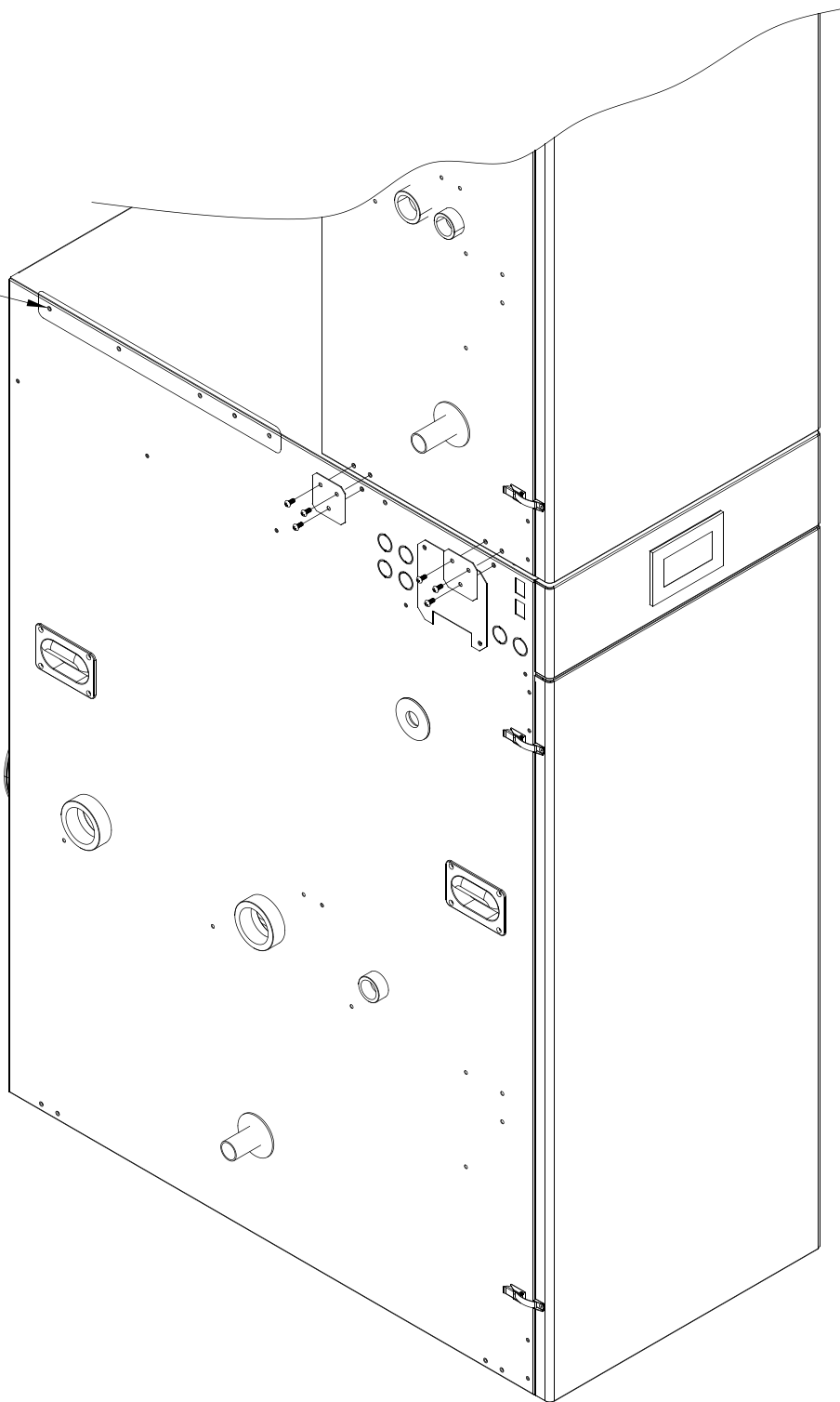

Figure 3-5: Boiler Stacking

4 Venting

WARNING

Asphyxiation Hazard. Failure to vent this boiler in accordance with these instructions could cause products of combustion to enter the building resulting in severe property damage, personal injury or death.

- Do not use a barometric damper, draft hood or vent damper with this boiler.
- Do not locate vent termination under a deck.
- Do not locate vent termination where exposed to prevailing winds.
- Do not locate combustion air termination where chlorines, chlorofluorocarbons (CFC's), petroleum distillates, detergents, volatile vapors or other chemicals are present. Severe boiler corrosion and failure will result.
- Use specified vent and combustion air pipe diameters.
- Do not interchange vent systems or materials unless otherwise specified.
- Do not apply thermal insulation to vent pipe or fittings.
- Moisture and ice may form on surface around vent termination. To prevent deterioration, surface must be in good repair (sealed, painted, etc.).
- Do not allow low spots in the vent where condensate may pool.
- The CPVC vent materials supplied with this boiler do not comply with *Natural Gas and Propane Installation Code*, CAN/CSA B149.1.S1-07 and are not approved for use in Canadian jurisdictions that require vent systems be listed to ULC S636-2008. In these jurisdictions, vent this boiler using either stainless steel Special Gas vent or a listed ULC S636 Class IIB venting system.

A. General Guidelines

1. Listed Vent/Combustion Air Systems

- a. Install vent system in accordance with *National Fuel Gas Code*, ANSI Z223.1/NFPA 54 or *Natural Gas and Propane Installation Code*, CAN/CSA B149.1 Installation Code for Canada, or, applicable provisions of local building codes. Contact local building or fire officials about restrictions and installation inspection in your area.
- b. The Alpine may be installed as a direct vent/sealed combustion boiler or with optional room air for combustion. Direct vent is recommended for residential applications. For direct vent, pipe combustion air from the outdoors directly to the boiler cabinet. Room air is optional for commercial applications. For room air, provide combustion and ventilation air per the *National Fuel Gas Code*, ANSI Z223.1, or, in Canada, *Installation Code for Gas Burning Appliances and Equipment*, CGA Standard B149.
- c. The following combustion air/vent system options are listed for use with the Alpine boilers (refer to Table 4-1):

- i. Two-Pipe CPVC/PVC Vent/Combustion Air System** - Separate CPVC/PVC pipe serves to expel products of combustion and separate PVC pipe delivers fresh outdoor combustion air. Refer to Part B for specific details.

- ii. Two-Pipe Polypropylene Vent/Combustion Air System** - Separate rigid or flexible polypropylene pipe serves to expel products of combustion and separate rigid polypropylene or PVC pipe delivers fresh outdoor combustion air. Refer to Part C for specific details.

- iii. Two-Pipe Stainless Steel Vent/Combustion Air System** - Separate stainless steel pipe serves to expel products of combustion and separate PVC or galvanized steel pipe delivers fresh outdoor combustion air. Refer to Part D for specific details.

- iv. Room Air for Combustion** - CPVC/

PVC, polypropylene, or stainless steel pipe serves to expel products of combustion and combustion air is supplied from the boiler room. Refer to Part E for specific details.

2. Vent/Combustion Air Piping

- a. Do not exceed maximum vent/combustion air lengths listed in Table 4-2. Vent/combustion air length restrictions are based on equivalent length of vent/combustion air pipe (total length of straight pipe plus equivalent length of fittings). Table 4-3 lists equivalent lengths for fittings. Do not include vent/combustion air terminals in equivalent feet calculations. Use vent/combustion air equivalent length worksheet provided in Table 4-4.

4 Venting A. General Guidelines (continued)

Table 4-1: Vent/Combustion Air Intake System Options

Vent & Intake Materials	Option		Penetration Through Structure	Termination	Figures	Component Table	Reference Section
Standard CPVC/PVC Two-Pipe, CPVC/PVC Vent and PVC Air Intake	1	Intake	Horizontal Sidewall	90° Elbow w/ Screen	4-6, 4-7	4-11, 4-12	A, B
		Vent	Horizontal Sidewall	Coupling w/ Screen			
	2	Intake	Horizontal Sidewall	Iplex Low Profile	4-8	4-13	
		Vent	Horizontal Sidewall				
	3	Intake	Horizontal Sidewall	90° Elbow w/ Screen	4-6, 4-7, 4-9	not provided	
		Vent	Vertical Roof	Coupling w/ Screen			
	4	Intake	Vertical Roof	(2) 90° Elbows w/ Screen	4-9	4-14	
		Vent	Vertical Roof	Coupling w/ Screen			
	5	Intake	N/A - Room Air		4-6, 4-7	not provided	
		Vent	Horizontal Sidewall	90° Elbow or Tee w/ Screen			
	6	Intake	N/A - Room Air		4-9	not provided	
		Vent	Vertical Roof	Coupling w/ Screen			
Optional Polypropylene Two-pipe, Rigid PP Vent or Flexible PP Vent (Vertical Only) and Rigid PP or PVC Air Intake	7	Intake	Horizontal Sidewall	UV Resistant 90° Elbow w/Screen	4-6, 4-7	4-22, 4-23, 4-24	A, C
		Vent	Horizontal Sidewall	UV Resistant Straight Pipe w/Screen			
	8	Intake	Horizontal Sidewall	Iplex Low Profile	4-8	4-13, 4-22, 4-23, 4-24	
		Vent	Horizontal Sidewall				
	9	Intake	Horizontal Sidewall	UV Resistant 90° Elbow w/Screen	4-6, 4-7, 4-9	4-22, 4-23, 4-24	
		Vent	Vertical Roof	UV Resistant Straight Pipe w/Screen			
	10	Intake	Vertical Roof	(2) UV Resistant 90° Elbows w/Screen	4-9	4-22, 4-23, 4-24	
		Vent	Vertical Roof	UV Resistant Straight Pipe w/Screen			
	11	Intake	N/A - Room Air		4-6, 4-7	4-22, 4-23, 4-24	
		Vent	Horizontal Sidewall	UV Resistant 90° Elbow w/Screen			
	12	Intake	N/A - Room Air		4-9	4-22, 4-23, 4-24	
		Vent	Vertical Roof	UV Resistant Straight Pipe w/Screen			
Optional Stainless Steel Two-pipe, SS Vent and Galvanized Steel or PVC Air Intake	13	Intake	Horizontal Sidewall	90° Elbow w/Screen	4-6, 4-7	4-30, 4-31, 4-32	A, D
		Vent	Horizontal Sidewall	Straight Termination w/Screen			
	14	Intake	Horizontal Sidewall	90° Elbow w/Screen	4-6, 4-7, 4-9	4-30, 4-31, 4-32	
		Vent	Vertical Roof	Straight Termination w/Screen			
	15	Intake	Vertical Roof	(2) 90° Elbows w/Screen	4-9	4-30, 4-31, 4-32	
		Vent	Vertical Roof	Straight Termination w/Screen			
	16	Intake	N/A - Room Air		4-6, 4-7	4-30, 4-31, 4-32	
		Vent	Horizontal Sidewall	90° Elbow or Tee w/Screen			
	17	Intake	N/A - Room Air		4-9	4-30, 4-31, 4-32	
		Vent	Vertical Roof	90° Elbow or Tee w/Screen			

4 Venting A. General Guidelines (continued)

**Table 4-2: Vent and Combustion Air Pipe Sizes and Equivalent Lengths
(Applies to All Listed Vent/Combustion Air System Options)**

Boiler Model	Option	Combustion Air Length			Vent Length			Approx. Derate at Max. Length (%)
		Pipe Dia., in. (mm)	Min., ft. (m)	Max., ft. (m)	Pipe Dia., in. (mm)	Min., ft. (m)	Max., ft. (m)	
ALP399C	Standard Diameter	4 (100 or 110)	0	100 (30.5)	4 (100 or 110)	2.5 (760)	100 (30.5)	5
	Reduced Diameter	3 (80)	0	50 (15.2)	3 (80)	2.5 (760)	50 (15.2)	5
ALP500C	Standard Diameter	4 (100 or 110)	0	100 (30.5)	4 (100 or 110)	2.5 (760)	100 (30.5)	11
	Reduced Diameter	3 (80)	0	50 (15.2)	3 (80)	2.5 (760)	50 (15.2)	12
ALP600C	Standard Diameter	4 (100 or 110)	0	100 (30.5)	6 (150 or 160)	2.5 (760)	200 (30.5)	7
	Reduced Diameter	4 (100 or 110)	0	50 (15.2)	4 (100 or 110)	2.5 (760)	50 (15.2)	10
ALP700C	Standard Diameter	4 (100 or 110)	0	100 (30.5)	6 (150 or 160)	2.5 (760)	200 (30.5)	11
	Reduced Diameter	4 (100 or 110)	0	50 (15.2)	4 (100 or 110)	2.5 (760)	50 (15.2)	15
ALP800C	Standard Diameter	4 (100 or 110)	0	100 (30.5)	6 (150 or 160)	2.5 (760)	200 (30.5)	14
	Reduced Diameter	4 (100 or 110)	0	50 (15.2)	4 (100 or 110)	2.5 (760)	50 (15.2)	15

**Table 4-3: Vent System and Combustion Air System Component Equivalent Length
(Applies to All Listed Vent/Combustion Air System Options)**

Component	Equivalent Length		
Nominal Diameter	3 in. (80 mm)	4 in. (100 or 110 mm)	6 in. (150 or 160 mm)
90° Elbow, Short Radius	10 ft. (3.0 m)	13 ft. (4.0 m)	22 ft. (6.7 m)
90° Elbow, Long Sweep/Sanitary	4.0 ft. (1.2 m)	9 ft. (2.7 m)	17 ft. (5.2 m)
45° Elbow	3.0 ft. (0.9 m)	4.5 ft. (1.4 m)	7.5 ft. (2.3 m)

Table 4-4: Vent and Combustion Air Equivalent Length Calculation Worksheet

Component	Combustion Air					Vent				
	Equivalent Length Per Piece	x	Quantity	=	Subtotal Equivalent Length	Equivalent Length Per Piece	x	Quantity	=	Subtotal Equivalent Length
Straight Pipe		x		=	A					E
90° Elbow, Short Radius		x		=	B					F
90° Elbow, Long Sweep/Sanitary		x		=	C					G
45° Elbow		x		=	D					H
	Combustion Air Total Equivalent Length			=	A+B+C+D	Vent Total Equivalent Length			=	E+F+G+H

Notes:

- Total equivalent length cannot exceed maximum equivalent length shown in Table 4-2.
- Use elbow equivalent lengths provided in Table 4-3.
- Combustion air and vent terminations do not count towards total equivalent length.
- Pressure drop for flexible polypropylene liner is 20% greater than for rigid pipe.

Multiply measured flexible polypropylene liner length by 1.2 to obtain equivalent length.

Example

Measured length = 35 ft.
Equivalent length = 35 ft. x 1.2 = 42 ft.

- Maximum equivalent length of flexible polypropylene liner is 48 ft. (14.6 m).

4 Venting A. General Guidelines (continued)

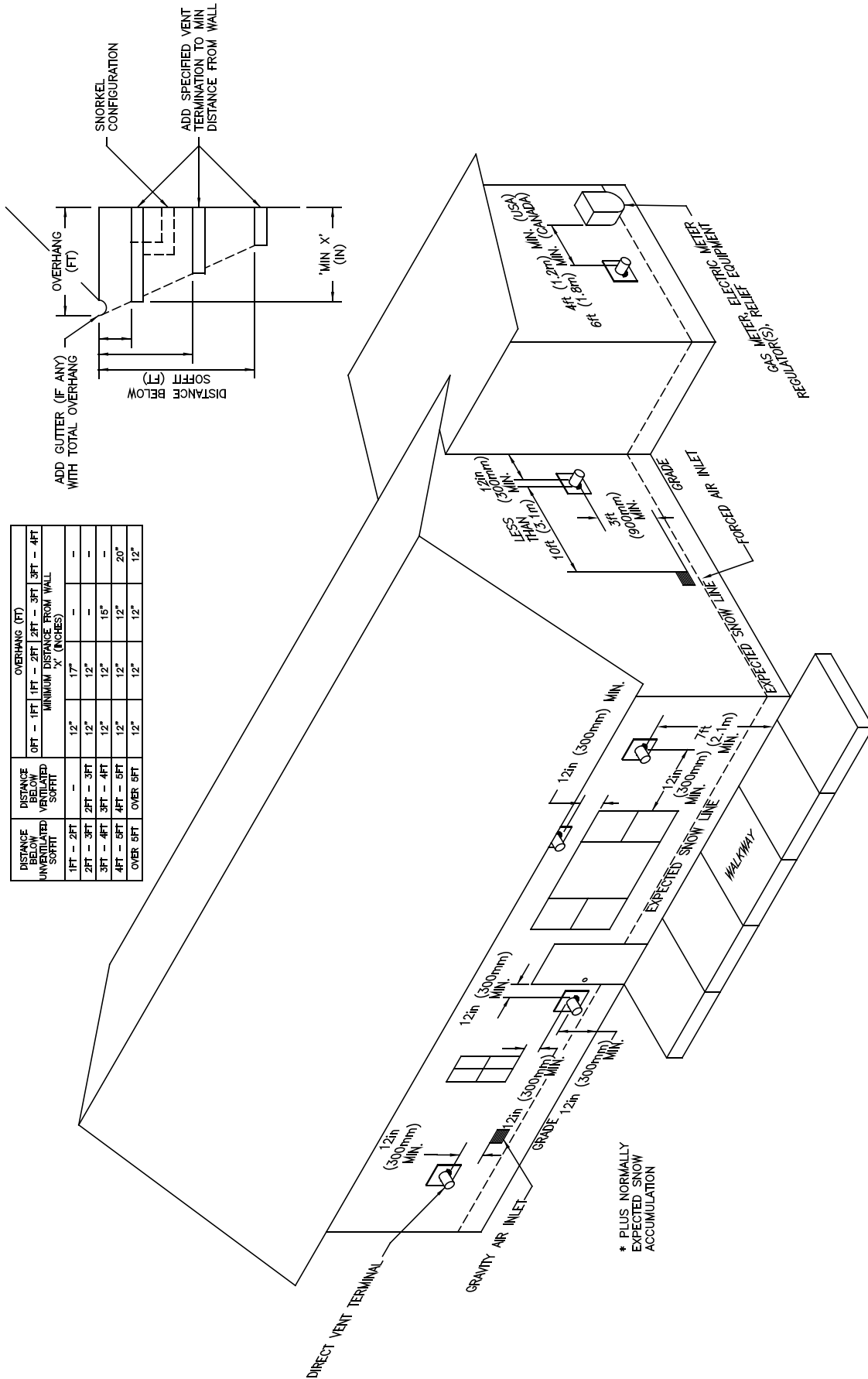

Figure 4-5: Location of Vent Terminal Relative to Windows, Doors, Grades, Overhangs, Meters and Forced Air Inlets - Two-Pipe System Vent Terminal (Shown), Two-Pipe System Air Intake Terminal (Not Shown)

4 Venting A. General Guidelines (continued)

- b. Maintain minimum clearance to combustible materials. See Table 3-2 for details.
- c. Enclose vent passing through occupied or unoccupied spaces above boiler with material having a fire resistance rating at least equal to the rating of adjoining floor or ceiling.

Note: For one or two family dwellings, fire resistance rating requirement may not need to be met, but is recommended.

- d. Slope horizontal vent pipe minimum 1/4 in/ft (21 mm/m) downward towards the boiler.
Les chaudières de catégories I, II et IV doivent présenter des tronçons horizontaux dont la pente montante est d'au moins 1/4 po par pied (21 mm/m) entre la chaudière et l'évent.
- e. If possible, slope horizontal combustion air pipe minimum 1/4 in/ft (21 mm/m) downward towards terminal. If not, slope towards boiler.
- f. Use noncombustible 3/4 in. pipe strap to support horizontal runs and maintain vent location and slope while preventing sags in pipe. Do not restrict thermal expansion or movement of vent system. Maximum support spacing 4 ft. (1.2 m). Avoid low spots where condensate may pool. Do not penetrate any part of the vent system with fasteners.

Les instructions d'installation du système d'évacuation doivent préciser que les sections horizontales doivent être supportées pour prévenir le fléchissement. Les méthodes et les intervalles de support doivent être spécifiés. Les instructions doivent aussi indiquer les renseignements suivants:

les chaudières de catégories II et IV doivent être installées de façon à empêcher l'accumulation de condensat: et si nécessaire, les chaudières de catégories II et IV doivent être pourvues de dispositifs d'évacuation du condensat.

- g. For multiple boiler installations with vertical roof terminals, separate vent pipes from multiple boilers may be piped through a common conduit or chase so that one roof penetration may be made.

3. Vent/Combustion Air Terminals

Install venting system components on exterior of building only as specifically required by these instructions (refer to Figure 4-5).

- a. Use only listed vent/combustion air terminals.
 - i. Horizontal Sidewall Venting: Use coupling for vent and 90° elbow pointed down for combustion air as shown in Figure 4-6 or Figure 4-7. If using room air for combustion, use 90° elbow or tee for vent. Alternate low profile termination is shown in Figure 4-8.
 - ii. Vertical Roof Venting: Use coupling on vent and two 90° elbows turned downwards for combustion air as shown in Figure 4-9 and Figure 4-10.
- b. Maintain correct clearance and orientation between vent and combustion air terminals.
 - i. Space center lines of vent and combustion air terminals minimum 12 in. (300 mm) apart. 36 in. (915 mm) spacing is recommended.
 - ii. If possible, locate vent and combustion air terminals on the same wall to prevent nuisance shutdowns. If not, boiler may be installed with roof vent terminal and sidewall combustion air terminal.

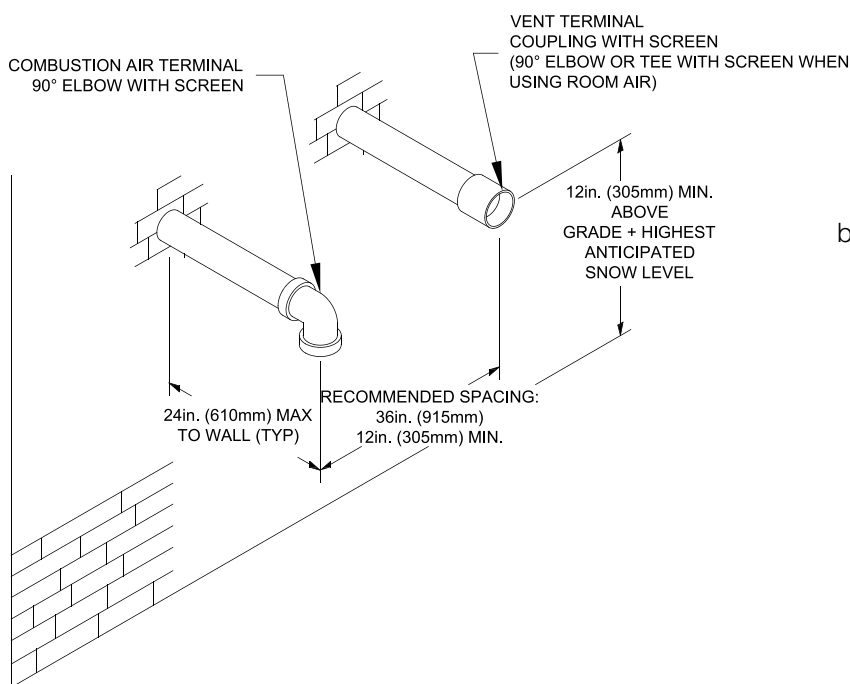

Figure 4-6: Direct Vent - Sidewall Standard Terminations

4 Venting A. General Guidelines (continued)

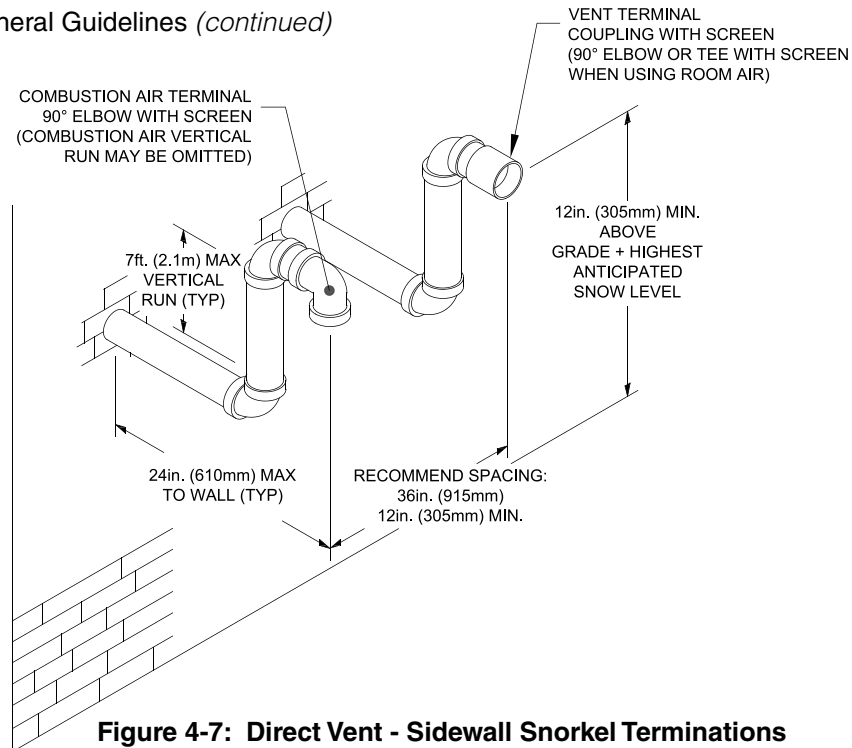

Figure 4-7: Direct Vent - Sidewall Snorkel Terminations

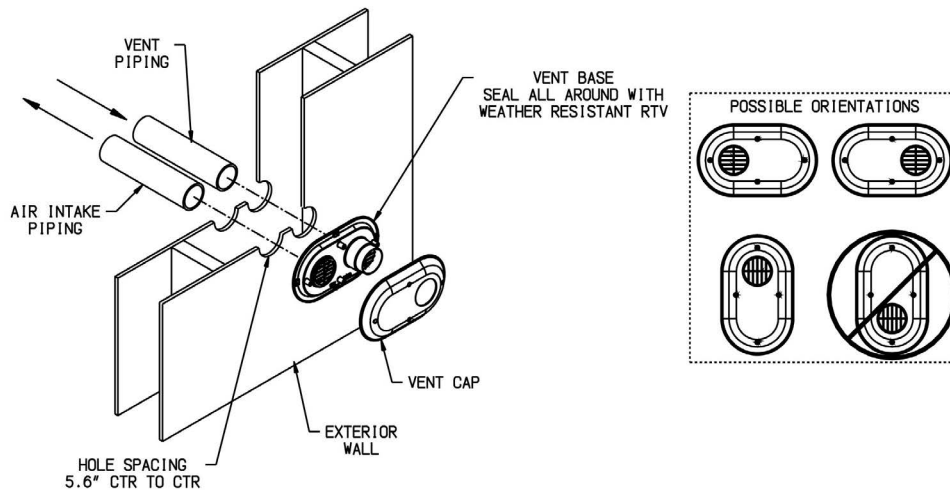

Figure 4-8: Direct Vent - Sidewall Low Profile Termination

- iii. When installed on the same wall, locate vent terminal at same height or higher than combustion air terminal.
- c. Locate bottom of vent and combustion air terminals at least 12 in. (300 mm) [18 in. (460 mm) in Canada] above the normal snow line and at least 12 in. (300 mm) above grade level.
- d. Locate vent and combustion air terminals at least 12 in. (300 mm) from any door, window, or gravity inlet into the building.
- e. Do not install vent terminal directly above windows or doors.
- f. Locate bottom of vent terminal at least 3 ft. (900 mm) above any forced air inlet located within 10 ft. (3.0 m).
- g. If window and/or air inlet is within 4 ft. (1.2 m) of an inside corner, maintain at least 6 ft. (1.8 m) spacing between terminal and adjoining wall of inside corner.
- h. Locate bottom of vent terminal at least 7 ft. (2.1 m) above a public walkway.
- i. Maintain minimum clearance of at least 4 ft. (1.2 m) [3 ft. (900 mm) in Canada] horizontally between vent terminal and gas meters, electric meters, regulators, and relief equipment. Do not install vent terminal above or below this equipment.

4 Venting A. General Guidelines (continued)

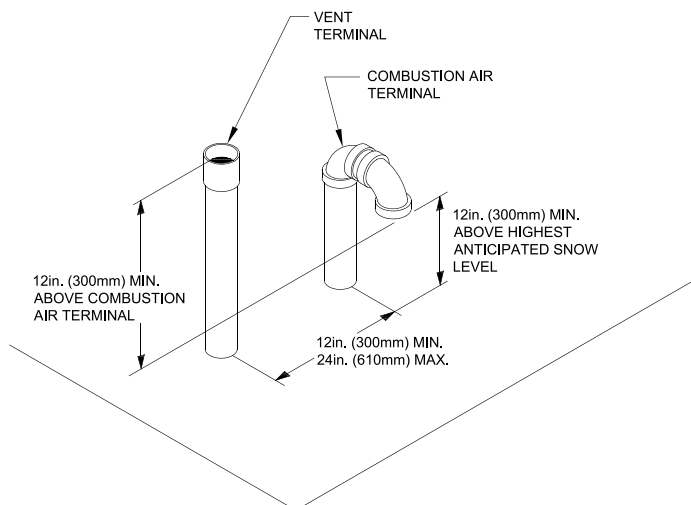
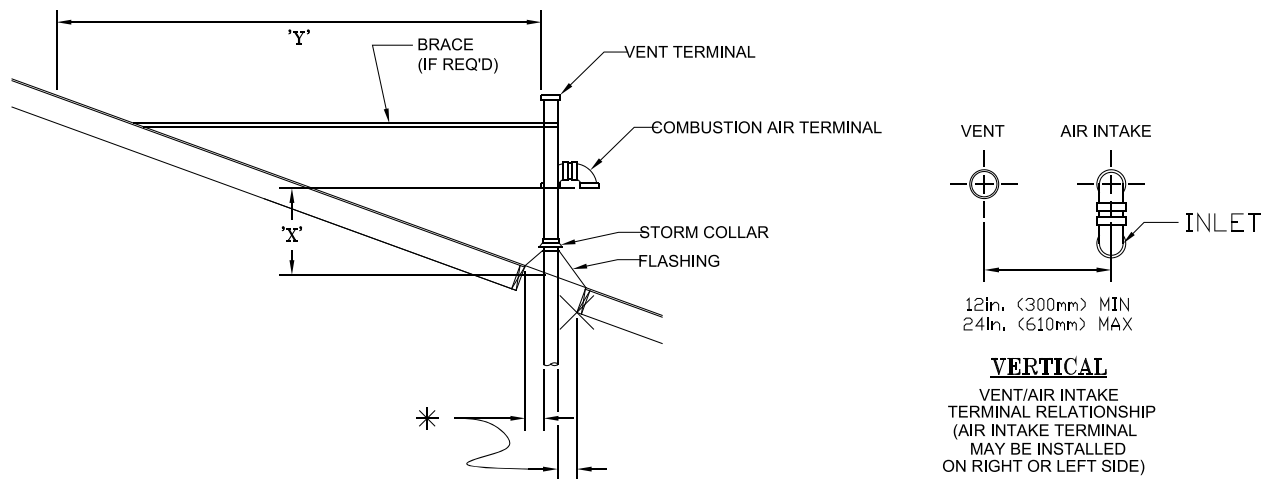

Figure 4-9: Direct Vent - Vertical Terminations

- j. Do not locate the vent terminal under decks or similar structures.
- k. Top of terminal must be at least 24 in. (600 mm) below ventilated eaves, soffits, and other overhangs. In no case may the overhang exceed 48 in. (1,200 mm). Where permitted by the authority having jurisdiction and local experience, the terminal may be located closer to unventilated soffits. The minimum vertical separation depends upon the depth of the soffit. See Figure 4-5 for details.

- l. Maintain minimum 12 in. (300 mm) horizontal spacing between vent terminal and a building corner.
- m. Under certain conditions, water in the flue gas may condense, and possibly freeze, on objects around the terminal including on the structure itself. If these objects are subject to damage by flue gas condensate, they should be moved or protected.
- n. If possible, install the vent and combustion air terminals on a wall away from the prevailing wind. Reliable operation of this boiler cannot be guaranteed if terminals are subjected to winds in excess of 40 mph (64 km/hr).
- o. Do not locate combustion air terminal in areas that might contain combustion air contaminants, such as near swimming pools.
- p. For multiple boiler installations with horizontal wall terminals, maintain minimum 12 in. (300 mm) horizontal distance between adjacent boiler vent terminals. Maintaining greater spacing is recommended to avoid frost damage to building surfaces where vent terminations are placed.



* VENT PIPE MINIMUM CLEARANCE TO COMBUSTIBLE MATERIAL IS 1in. (25mm). COMBUSTION AIR PIPE MINIMUM CLEARANCE TO COMBUSTIBLE MATERIAL IS ZERO.

Figure 4-10: Direct Vent - Vertical Terminations with Sloped Roof

Extend vent/combustion air piping to maintain minimum vertical ('X') and minimum horizontal ('Y') distance of 12 in. (300 mm) [18 in. (460 mm) Canada] from roof surface. Allow additional vertical ('X') distance for expected snow accumulation.

4 Venting B. CPVC/PVC Venting *(continued)*

- q. For multiple boiler installations with vertical roof terminals, maintain minimum 12 in. (300 mm) horizontal distance between adjacent boiler vent terminals.

B. CPVC/PVC Venting

WARNING

Asphyxiation Hazard. Failure to follow these instructions could cause products of combustion to enter the building, resulting in severe property damage, personal injury, or death.

- Use all CPVC vent components (supplied with boiler) for near-boiler vent piping before transitioning to Schedule 40 PVC pipe (ASTM 2665) components for remainder of vent system.
- Use CPVC vent components within any interior space where air cannot circulate freely, including through vertical or horizontal chase ways, inside a stud wall, in closets, and through wall penetrations.
- The use of cellular core PVC (ASTM F891), cellular core CPVC or Radel (polyphenolsulfone) is prohibited.
- All condensate that forms in the vent must be able to drain back to the boiler.

NOTICE: Do not exceed maximum vent/combustion air system length. Refer to “2. Vent/Combustion Air Piping” under “A. General Guidelines” of this section for maximum vent/combustion air system length. Use only vent and combustion air terminals and terminal locations shown in “3. Vent/Combustion Air Terminals” under “A. General Guidelines” of this section.

1. Components

- a. See Table 4-11 for CPVC/PVC vent and combustion air components included with boiler.
- b. See Table 4-12 for CPVC/PVC installer provided vent and combustion air components required for optional horizontal snorkel terminals shown in Figure 4-7.
- c. See Table 4-13 for installer provided Ipx Low Profile Vent Termination Kits.
- d. See Table 4-14 for CPVC/PVC installer provided vent and combustion air components required for optional vertical roof terminals shown in Figure 4-9.

2. Field Installation of CPVC/PP/SS Vent Connector

Refer to Figure 4-15 and following steps:

- a. Position the vent connector and gasket onto boiler rear panel and insert vent connector into heat exchanger vent outlet.
- b. Align vent connector plate and gasket clearance holes with rear panel engagement holes. Be sure combustion sample port is on left side looking at rear of boiler. Then, secure the connector and gasket to the panel with four mounting screws.

3. Near-Boiler Vent/Combustion Air Piping

Refer to Figure 4-16 and the following Steps:

- a. Apply supplied dielectric grease to gasket inside vent connector. The grease will prevent gasket rupture when inserting vent pipe and gasket deterioration due to condensate exposure.
- b. Install provided Schedule 40 x 30 in. (760 mm) long CPVC pipe into the vent section of the connector with a slight twisting motion and secure by tightening the clamp.
- c. All CPVC vent components supplied with boiler inside vent carton [Schedule 40 x 30 in. (760 mm) long CPVC pipe and Schedule 80 CPVC 90° Elbow] must be used for near-boiler piping before transitioning to Schedule 40 PVC (ASTM 2665) pipe components for remainder of vent system. The 30 in. (760 mm) long CPVC straight pipe may be cut to accommodate desired vent configuration provided both pieces are used in conjunction with CPVC 90° Elbow before any PVC components are used. Ensure that the CPVC 90° Elbow is the first elbow used in the vent system as it exits the boiler.
- d. Apply PVC primer and cement and insert Schedule 40 PVC combustion air pipe (installer provided) into the combustion air connector with a slight twisting motion.

4. System Assembly

WARNING

Asphyxiation Hazard. CPVC/PVC vent piping and fittings rely on glued joints for proper sealing. Follow all manufacturer instructions and warnings when preparing pipe ends for joining and using the primer and the cement.

4 Venting B. CPVC/PVC Venting (continued)

⚠ WARNING

Asphyxiation Hazard. Apply supplied dielectric grease to gasket inside vent section of vent connector. Failure to apply the grease could result in flue gas leaks from gasket rupture during vent pipe installation or gasket deterioration due to condensate exposure.

Table 4-11: CPVC/PVC Vent & Air Intake Components Included With Boiler

Vent & Air Intake Components	Quantity	
	Models ALP399C & ALP500C Standard 4 in. Intake/4 in. Vent Kit includes	Models ALP600C, ALP700C & ALP800C Standard 4 in. Intake/6 in. Vent Kit includes
Schedule 40 PVC Coupling	1	1
Schedule 40 PVC 90° Elbow	1	1
Stainless Steel Screen	2	2
30 in. Schedule 40 CPVC Pipe	1	1
Schedule 80 CPVC 90° Elbow	1	1

Table 4-12: CPVC/PVC Vent & Air Intake Components (Installer Provided) Required for Optional Horizontal Snorkel Termination

Vent Components	Quantity	
	ALP399C & ALP500C Horizontal (Snorkel) 4 in. Intake/4 in. Vent	ALP600C, ALP700C & ALP800C Horizontal (Snorkel) 4 in. Intake/6 in. Vent
Schedule 40 PVC Pipe x up to 7 ft. (2.1 m) max. vertical run	2	2
Schedule 40 PVC 90° Elbow	4	4
Schedule 40 PVC Pipe x 6 in. (150 mm) min. horizontal run	2	1
Schedule 40 PVC Pipe x 9 in. (230 mm) min. horizontal run	N/A	1

Table 4-13: Components Required for Optional Iplex Low Profile Sidewall Termination

Description	Iplex Part Number	U.S. Boiler Company Part Number	Applicable to Boiler Sizes
3 in. Low Profile Termination Kit	196985	106415-03	399 (reduced dia.) 500 (reduced dia.)
4 in. Low Profile termination Kit	196986	106415-04	399 (standard dia.) 500 (standard dia.) 600 (reduced dia.) 700 (reduced dia.) 800 (reduced dia.)

Table 4-14: CPVC/PVC Vent & Air Intake Components (Installer Provided) required for Optional Vertical Roof Termination

Vent Components	Quantity	
	ALP399C & ALP500C Vertical (Roof) Termination, 4 in. Intake/4 in. Vent	ALP600C, ALP700C & ALP800C Vertical (Roof) Termination, 4 in. Intake/6 in. Vent
Schedule 40 PVC Coupler	1	1
Schedule 40 PVC 90° Elbow	2	2
Schedule 40 CPVC Pipe x 6 in. (150 mm) min. horizontal run	1	1

4 Venting B. CPVC/PVC Venting (continued)

- a. Plan venting system to avoid possible contact with plumbing or electrical wires. Start at vent connector at boiler and work towards vent termination.
- b. Design the vent system to allow 3/8 in. (9.5 mm) of thermal expansion per 10 ft. (3.0 m) of CPVC/PVC pipe. Runs of 20 ft. (6.1 m) or longer that are restrained at both ends must use an offset or expansion loop. Refer to Figure 4-18 and Table 4-17.
- c. All CPVC/PVC vent and combustion air pipe joints must be cleaned with primer and glued with cement. Follow all manufacturer instructions and warnings when preparing pipe ends for joining and using the primer and the cement.

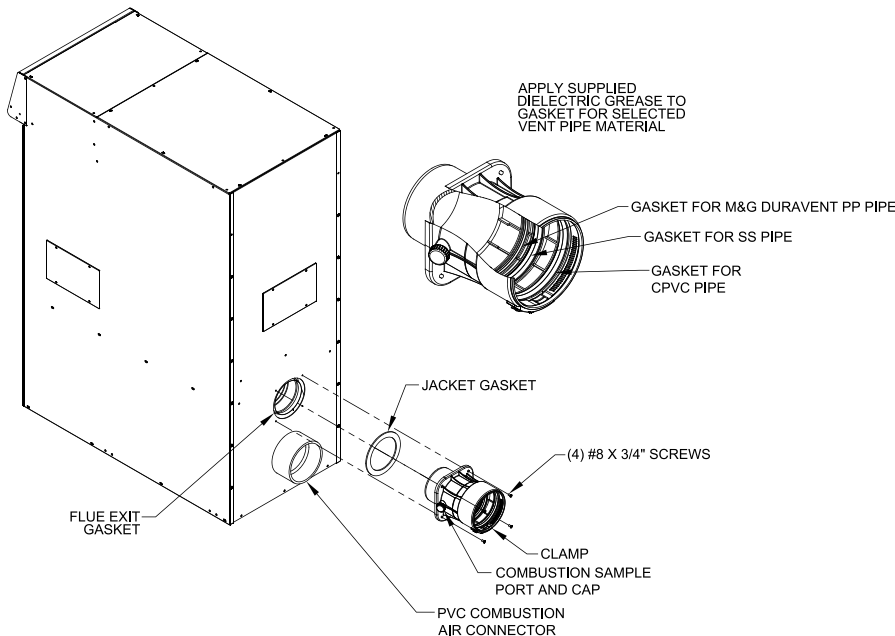

Figure 4-15: Field Installation CPVC/PP/SS Vent Connector

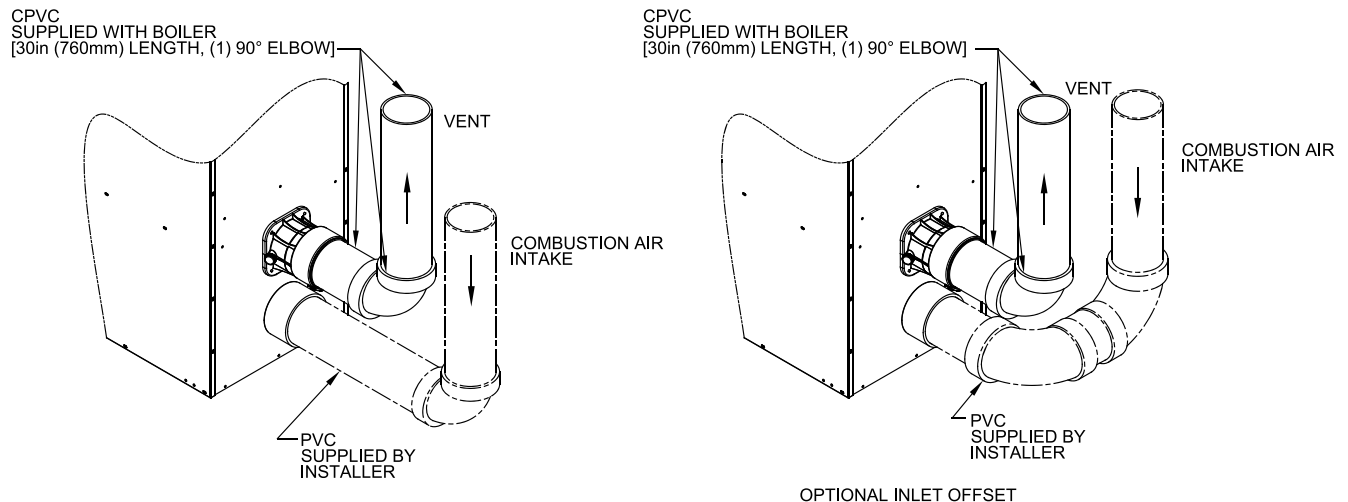

Figure 4-16: Near-Boiler Vent/Combustion Air Piping

5. Horizontal Sidewall Termination

- a. Standard Two-Pipe Termination

See Figure 4-6.

- i. Vent Piping

Running PVC vent pipe inside Enclosures and through Walls:

- PVC vent pipe must be installed in such way as to permit adequate air circulation around the outside of the pipe to prevent internal wall temperature rising above ANSI Z21.13 standard specified limit.
- Do not enclose PVC venting. Use higher temperature rated CPVC pipe in enclosed spaces or to penetrate combustible or non-combustible walls.

4 Venting B. CPVC/PVC Venting (continued)

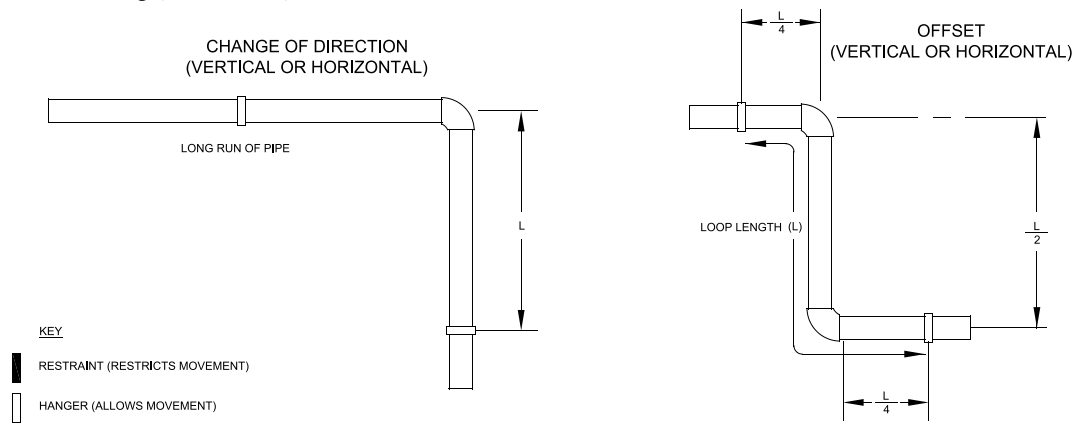

Table 4-17: Expansion Loop Lengths

Nominal Pipe Dia. (In.)	Length of Straight Run		Loop Length "L"	
	ft.	m	in.	mm
3	20	6.1	53	1350
	30	9.1	65	1650
	40	12	75	1900
	50	15	84	2130
	60	18	92	2340
4	20	6.1	60	1520
	30	9.1	74	1880
	40	12	85	2159
	50	15	95	2413
	60	18	104	2642
6	20	6.1	73	1850
	30	9.1	90	2290
	40	12	103	2620
	50	15	116	2950
	60	18	127	3230

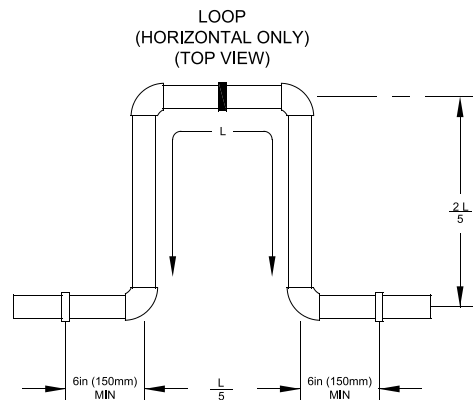

Figure 4-18: CPVC/PVC Expansion Loop and Offset

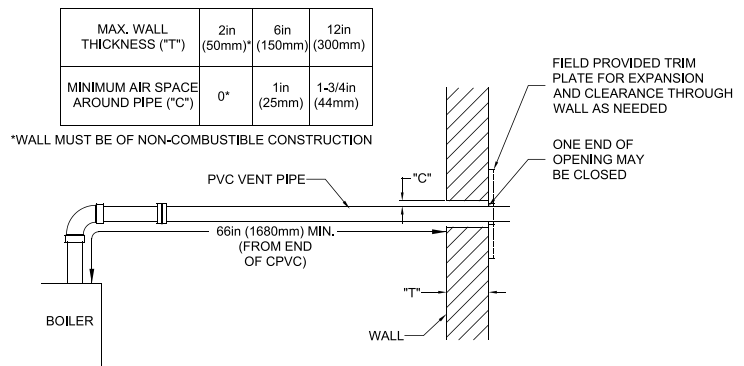

Figure 4-19: Wall Penetration Clearances for PVC Vent Pipe

- PVC vent pipe may not be used to penetrate combustible or non-combustible walls unless all following three conditions are met simultaneously (see Figure 4-19):
 - The wall penetration is at least 66 in. (1680 mm) from the boiler as measured along the vent
 - The wall is 12 in. (300 mm) thick or less
 - An air space of at least of that shown in Figure 4-19 is maintained around outside of the vent pipe to provide air circulation.
- If above three conditions cannot be met simultaneously when penetrating a combustible wall, use CPVC pipe for wall penetration.
- Size and cut wall opening such that a minimal clearance is obtained and to allow easy insertion of vent pipe.

Wall thimbles for CPVC/PVC pipe are available from U.S. Boiler Company: P/N's 102180-01 (3 in.), 102181-01 (4 in.), 103419-01(6 in.).

- Apply sealant between vent pipe and wall opening to provide weather-tight seal. Sealant should not restrain the expansion of the vent pipe.
- Install contractor provided optional trim plate on wall outside surface to cover wall opening (see Figure 4-19).
- Secure trim plate to wall with nails or screws and seal ID and plate OD or perimeter with sealant material.

4 Venting B. CPVC/PVC Venting (continued)

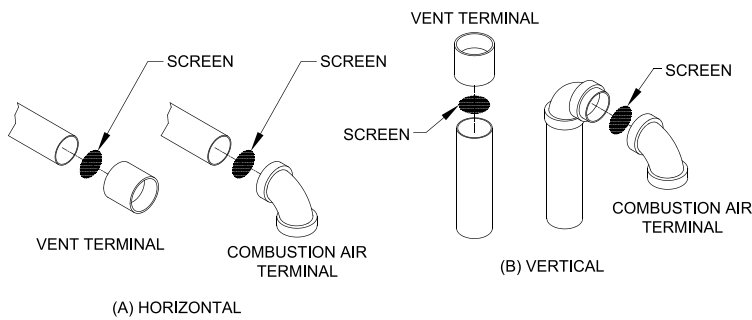

Figure 4-20: Screen Installation

- Install screen and vent terminal (supplied with boiler). See Figure 4-20 for appropriate configuration details.

NOTICE: Methods of securing and sealing terminals to the outside wall must not restrain the thermal expansion of the vent pipe.

ii. Combustion Air Piping

- Size combustion air pipe wall penetration opening to allow easy insertion of the pipe.
- Install screen and combustion air terminal (supplied with boiler). See Figure 4-20 for appropriate configuration details.
- Apply sealant between combustion air pipe and wall opening to provide weather-tight seal.

b. Optional Two-Pipe Snorkel Termination

See Figure 4-7.

This installation will allow a maximum of 7 ft. (2.1 m) vertical exterior run of the vent/combustion air piping to be installed on the CPVC/PVC horizontal venting application.

NOTICE: Exterior run to be included in equivalent vent/combustion air lengths.

i. Vent Piping

- After penetrating wall, install a Schedule 40 PVC 90° elbow so that the elbow leg is in the up direction.
- Install maximum vertical run of 7 ft. (2.1 m) of Schedule 40 PVC vent pipe. See Figure 4-7.
- At top of vent pipe length install another PVC 90° elbow so that elbow leg is opposite the building's exterior surface.
- Install screen and vent terminal (supplied with boiler), see Figure 4-20 for appropriate configuration.

- Brace exterior piping if required.

ii. Combustion Air Piping

- After penetrating wall, install a Schedule 40 PVC 90° elbow so that elbow leg is in the up direction.
- Install maximum vertical run of 7 ft. (2.1 m) of Schedule 40 PVC vent pipe. See Figure 4-7.
- At top of air pipe length install another PVC 90° elbow so that elbow leg is opposite the building's exterior surface.
- Install screen and combustion air terminal (supplied with boiler). See Figure 4-20 for appropriate configuration.
- Brace exterior piping if required.

6. Vertical Roof Termination

a. Standard Two-Pipe Termination

See Figures 4-9 and 4-10.

i. Vent Piping

- Install fire stops where vent passes through floors, ceilings or framed walls. The fire stop must close the opening between the vent pipe and the structure.
- Whenever possible, install vent straight through the roof. Refer to Figures 4-9 and 4-10.
 - Size roof opening to maintain minimum clearance of 1 in. (25 mm) from combustible materials.
 - Extend vent pipe to maintain minimum vertical and horizontal distance of 12 in. (300 mm) from roof surface. Allow additional vertical distance for expected snow accumulation. Provide brace as required.

NOTICE: Vertical venting and combustion air roof penetrations (where applicable) require the use of roof flashing and storm collar, which are not supplied with boiler, to prevent moisture from entering the structure.

- Install storm collar on vent pipe immediately above flashing. Apply Dow Corning Silastic 732 RTV Sealant or equivalent between vent pipe and storm collar to provide weather-tight seal.

4 Venting B. CPVC/PVC Venting (continued)

- Install screen and vent terminal (supplied with boiler). See Figure 4-20 for appropriate configuration.
 - Brace exterior piping if required.
- ii. Combustion Air Piping
- If possible, locate combustion air termination on the same roof location as the vent termination to prevent nuisance boiler shutdowns. Combustion air terminal may be installed closer to roof than vent. Alternatively, boiler may be installed with vertical roof vent terminal and sidewall combustion air terminal.
 - Size roof opening to allow easy insertion of combustion air piping and allow proper installation of flashing and storm collar to prevent moisture from entering the structure.
 - Use appropriately designed vent flashing when passing through roofs. Follow flashing manufacturers' instructions for installation procedures.
 - Extend combustion air pipe to maintain minimum vertical and horizontal distance of 12 in. (300 mm) from roof surface. Allow additional vertical distance for expected snow accumulation. Provide brace as required.
 - Install storm collar on combustion air pipe immediately above flashing. Apply Dow Corning Silastic 732 RTV Sealant or equivalent between combustion air pipe and storm collar to provide weather-tight seal.
 - Install screen and combustion air terminal (supplied with boiler). See Figure 4-20 for appropriate configuration.
 - Brace exterior piping if required.

C. Polypropylene Venting

NOTICE: Do not exceed maximum vent/combustion air system length. Refer to "2. Vent/Combustion Air Piping" under "A. General Guidelines" of this section for maximum vent/combustion air system length. Use only vent and combustion air terminals and terminal locations shown in "3. Vent/Combustion Air Terminals" under "A. General Guidelines" of this section.

⚠ WARNING

Asphyxiation Hazard. Follow these instructions and the installation instructions included by the listed polypropylene venting component manufacturers, whichever applicable. Failure to do so could cause products of combustion to enter the building, resulting in severe property damage, personal injury or death. Where a conflict arises between a manufacturer's instructions and these instructions, the more restrictive instructions shall govern.

- Do not mix vent components or joining methods for listed manufacturers.
- Examine all components for possible shipping damage prior to installation.
- All condensate that forms in the vent must be able to drain back to the boiler.

1. Components

- a. Listed polypropylene vent system manufacturers are shown in Table 4-21. It is the responsibility of the installing contractor to procure polypropylene vent system pipe and related components.
 - i. All listed polypropylene vent system manufacturers comply with the requirements of ULC-S636-08 'Standard for Type BH Gas Venting Systems'.
 - ii. Centrotherm Eco Systems InnoFlue SW Rigid Vent and Flex Flexible Vent, and Z-Flex Z-Dens Single Wall Rigid Vent and Flexible Vent comply with the requirements of UL 1738 'Standard for Safety for Venting Systems'.
- b. See Table 4-22 for specific M&G DuraVent components.
- c. See Table 4-23 for specific Centrotherm Eco Systems components.
- d. See Table 4-24 for specific Z-Flex Z-Dens components.

2. Field Installation of Polypropylene Adapters

- a. Vent Connector (see Figure 4-25)
 - i. No adapter is required for M&G DuraVent PolyPro vent pipe unless vent diameter is reduced per Table 4-2. See Table 4-22 for M&G DuraVent boiler adapters for reduced vent diameter. An adapter is always required for Centrotherm InnoFlue vent pipe and Z-Flex Z-Dens vent pipe. See Table 4-23 for Centrotherm InnoFlue boiler adapters and Table 4-24 for Z-Flex Z-Dens boiler adapters.

4 Venting B. CPVC/PVC Venting (continued)

- ii. Install CPVC/PP/SS vent connector. Follow instructions in “2. Field Installation of CPVC/PP/SS Vent Connector” under “B. CPVC/PVC Venting.”
 - iii. Apply provided dielectric grease to gasket inside vent connector that will be in contact with adapter.
 - iv. Push and twist adapter into vent system connector until adapter bottoms out.
 - v. Tighten clamp to secure adapter in CPVC/PP/SS vent connector.
- b. Combustion Air Connector (see Figure 4-26)
- i. No adapter is required if using PVC combustion air pipe. An adapter is required for both M&G DuraVent PolyPro (see Table 4-22), Centrotherm InnoFlue (see Table 4-23) and Z-Flex Z-Dens (see Table 4-24) combustion air pipes.
 - ii. Insert adapter into combustion air connector. Adapter has gasket to seal against combustion air connector.

3. System Assembly

WARNING

Asphyxiation Hazard. Vent systems made by listed PP vent system manufacturers rely on gaskets for proper sealing. When these vent systems are used, take the following precautions:

- Do not mix vent components or joining methods for listed manufacturers.
- Examine all components for possible shipping damage prior to installation.
- All condensate that forms in the vent must be able to drain back to the boiler.

- a. Plan venting system to avoid possible contact with plumbing or electrical wires. Start at vent connector at boiler and work towards vent termination.
- b. Follow all manufacturer instructions and warnings when preparing pipe ends for joining and when assembling the vent/combustion air system.
- c. Use locking band clamps at all vent pipe joints. See Figure 4-27 or Figure 4-28 for locking band clamp installation.

NOTICE: The venting system must be free to expand and contract and supported in accordance with installation instructions included by the original listed polypropylene venting component manufacturers, whichever applicable. Polypropylene pipe sections must be disengaged 1/4 to 5/8 in. (6 mm to 16 mm) per joint to allow for thermal expansion.

4. Terminations

- a. For standard horizontal sidewall terminations, see Figures 4-6 and 4-7. For vertical roof terminations, see Figures 4-9 and 4-10. Use UV resistant components listed in Tables 4-22 through 4-24.
- b. If using M&G duravent PolyPro pipe, install screens per Figure 4-20. Remove gasket inside termination and install screen in place of gasket. If using Centrotherm InnoFlue or Z-Flex Z-Dens end pipe, screen fits onto end of pipe.
- c. For low profile sidewall termination, see Figure 4-8. Use low profile termination listed in Table 4-13 and adapter kit listed in Tables 4-22 through 4-24.

5. Running Flexible Polypropylene Vent (Liner) Through Unused Chimney Chase

WARNING

Asphyxiation Hazard. Flexible polypropylene vent must be installed only in an UNUSED chimney. A chimney, either single or multiple flue type, is considered UNUSED when none of the flues is being used for any appliance venting. Where one of the multiple flues is being used for an appliance venting, the flexible vent installation is not permitted through any of adjacent flues.

Table 4-21: Listed Polypropylene Vent System Manufacturers

Make	Model
M&G/DuraVent	PolyPro Single Wall Rigid Vent PolyPro Flex Flexible Vent (ALP399C and ALP500C)
Centrotherm Eco Systems	InnoFlue SW Rigid Vent Flex Flexible Vent (ALP399C and ALP500C)
Z-Flex Z-Dens	Z-Dens Single Wall Rigid Vent Z-Dens Flexible Vent (ALP399C and ALP500C)

4 Venting C. Polypropylene Venting (continued)

Table 4-22: M&G DuraVent PolyPro Polypropylene Vent/Combustion Air System Components

Boiler Model	Nominal Pipe Diameter	Combustion Air				Vent			Iplex Low Profile Termination Adapter Kit: Pipe Adapter & Wall Plate
		Pipe Joint Locking Band Clamp	Boiler Adapter	Sidewall Termination: UV Resistant 90° Elbow w/Screen	Roof Termination: (2) UV Resistant 90° Elbows w/Screen	Boiler Adapter	Sidewall* or Roof Termination: UV Resistant Straight Pipe w/ Screen	Flex Chimney Lining Kit	
ALP399C (standard dia.) ALP500C (reduced dia. vent)	3 in. (80 mm)	3PPS-LB2 or 3PPS-LBC	4PPS-ADL with 4PPS-R3L	Elbow: 3PPS-E90BL Screen: 3PPS-BG	Elbow: 3PPS-E90BL Screen: 3PPS-BG	4PPS-R3L	Pipe: 3PPS-12BL Screen: 3PPS-BG	3PPS-FKL	3PPS-HLKL
ALP399C (standard dia.) ALP500C (standard dia.) ALP600C (reduced dia. vent) ALP700C (reduced dia. vent) ALP800C (reduced dia. vent)	4 in. (100 mm)	4PPS-LB2 or 4PPS-LBC	4PPS-ADL	Elbow: 4PPS-E90BL Screen: 4PPS-BG	Elbow: 4PPS-E90BL Screen: 4PPS-BG	ALP399C & ALP500C: No Adapter Required; ALP600C, ALP700C, ALP800C: 6PPS-R5L with 5PPS-R4L	Pipe: 4PPS-12BL Screen: 4PPS-BG	4PPS-FKL	4PPS-HLKL
ALP600C (standard dia. vent) ALP700C (standard dia. vent) ALP800C (standard dia. vent)	6 in. (150 mm)	6PPS-LB2 or 6PPS-LBC	N/A	N/A	N/A	No Adapter Needed	Pipe: 6PPS-12BL Screen: 6PPS-BG	N/A	N/A

* Note: When using room air for combustion, use UV resistant 90° elbow or tee for sidewall vent termination. UV resistant 90° elbow part numbers: 3PPS-E90BL (3 in.), 4PPS-E90BL (4 in.), 6PPS-E90BL (6 in.). UV resistant tee part numbers: 3PPS-TBL (3 in.), 4PPS-TBL (4 in.), 6PPS-TBL (6 in.).

Table 4-23: Listed Polypropylene Pipe, Fittings and Terminations - Centrotherm Eco

Boiler Model	Nominal Pipe Diameter	Pipe Joint Locking Band Clamp	Combustion Air			Vent			Iplex Low Profile Adapter Kit: Pipe Adapter & Wall Plate
			Boiler Adapter	Sidewall Termination: UV Resistant 90° Elbow w/Screen	Roof Termination: (2) UV Resistant 90° Elbows w/Screen	Boiler Adapter	Sidewall* or Roof Termination: UV Resistant Straight Pipe w/ Screen	Flex Chimney Lining Kit	
ALP399C (reduced dia. vent) ALP500C (reduced dia. vent)	3 in. (80 mm)	IANS03	ISAGL0404 with ISRD0403	Elbow: ISELL0387UV Screen: IASPP03	Elbow: ISELL0387UV Screen: IASPP03	ISAAAL0404 and ISRD0403	Pipe: ISEP03 or ISEP0339 Screen: IASPP03	IFCK0325 or IFCK0335	ISLTK03
ALP399C (standard dia.) ALP600C (reduced dia. vent) ALP700C (reduced dia. vent) ALP800C (reduced dia. vent)	4 in. (110 mm)	IANS04	ISAGL0404	Elbow: ISEL0487UV Screen: IASPP04	Elbow: ISEL0487UV Screen: IASPP04	ALP399C & ALP500C: ISAAAL0404; ALP600C, ALP700C & ALP800C: ISAAAL0606 with ISRD0604	Pipe: ISEP04 or ISEP0439 Screen: IASPP04	IFCK0425 or IFCK0435	ISLTK04
ALP600C (standard dia. vent) ALP700C (standard dia. vent) ALP800C (standard dia. vent)	6 in. (160 mm)	IANS06 or IADHC0606	N/A	N/A	N/A	ISAAAL0606	Pipe: ISEP06 or ISEP0639 Screen: IASPP06	N/A	ISLTK06

* Note: When using room air for combustion, use UV resistant 90° elbow or tee for sidewall vent termination. UV resistant 90° elbow part numbers: ISEL0387UV (3 in.), ISEL0487UV (4 in.), ISEL0687UV (6 in.). UV resistant tee part numbers: ISTT0320 (3 in.), ISTT0420 (4 in.), ISTT0620 (6 in.).

See Centrotherm InnoFuel literature for other required component part numbers such as straight pipe, elbows, firestops, and vent supports.

4 Venting C. Polypropylene Venting (continued)

Table 4-24: Listed Polypropylene Pipe, Fittings and Terminations - Z-Flex Z-Dens

Boiler Model	Nominal Pipe Diameter	Pipe Joint Locking Band Clamp	Combustion Air			Vent			Ipex Low Profile Termination Adapter & Wall Plate
			Boiler Adapter	Sidewall Termination: UV Resistant 90° Elbow w/ Screen	Roof Termination: (2) UV Resistant 90° Elbows w/Screen	Boiler Adapter	Sidewall * or Roof Termination: UV Resistant Straight Pipe w/Screen	Flex Chimney Lining Kit	
ALP399C (reduced dia.) ALP500C (reduced dia.)	3 in. (80 mm)	ZZDLC3	ZZDCPVC4 with ZZDR43	Elbow: ZZDE387UV Screen: ZZDES3	Elbow: ZZDE387UV Screen: ZZDES3	ZZD144 with ZZDR43	Pipe: ZZDP3(*) UV Screen: ZZDES3	ZZDFK325 or ZZDFK335	N/A
ALP399C (standard dia.) ALP500C (standard dia.) ALP600C (reduced dia. vent) ALP700C (reduced dia. vent) ALP800C (reduced dia. vent)	4 in. (100 mm)	ZZDLC4	ZZDCPVC4	Elbow: ZZDE487UV Screen: ZZDES4	Elbow: ZZDE487UV Screen: ZZDES4	ZZD144: ALP600C, ALP700C, & ALP800C: ZZDCPVCCG6 with ZZDR65 & ZZDR64	Pipe: ZZDP4(*) Screen: ZZDES4	ZZDFK425 or ZZDFK435	N/A
ALP600C (standard dia. vent) ALP700C (standard dia. vent) ALP800C (standard dia. vent)	6 in. (150 mm)	ZZDLC6	ZZDCPVC4	Elbow: ZZDE687 Screen: ZZDES6	Elbow: ZZDE687 Screen: ZZDES6	ZZDCPVCCG6	Pipe: ZZDP6(*) Screen: ZZDES6	N/A	N/A

* Note: When using room air for combustion, use UV resistant 90° elbow or tee for sidewall vent termination. UV resistant 90° elbow part numbers: ZZDE387UV (3 in.), ZZDE487UV (4 in.), ZZDE687UV (6 in.).

UV resistant tee part numbers: ZZDT13 (3 in.), ZZDT14 (4 in.), ZZDT16 (6 in.).

See Z-Flex Z-Dens literature for other required component part numbers such as straight pipe, elbows, firestops and vent supports.

(*) - Pipe Length

NOTICE: Pressure drop for flexible polypropylene liner is 20% greater than from rigid pipe. Multiply measured flexible polypropylene liner length by 1.2 to obtain equivalent length. Maximum equivalent length of flexible polypropylene liner is 48 ft. (14.6 m).

- Models ALP399C and ALP500C are listed for vertical venting by installing flexible vent in an UNUSED masonry chimney/chase and supplying combustion air through a separate wall or roof combustion air terminal.
- Refer to Figure 4-29 for details of chimney chase installation.
- Flexible polypropylene pipe must be treated carefully and stored at temperatures higher than 41°F (5°C).
- Do not bend or attempt to install flexible pipe if it has been stored at lower ambient temperature without allowing the pipe to warm up to a higher temperature first.

WARNING

Asphyxiation Hazard. Bending or attempting to install flexible pipe if it has been stored at ambient temperature below 41°F (5°C) will cause material to become brittle and lead to cracks, resulting in flue gas leaks.

- Do not install flexible polypropylene pipe at an angle greater than 45 degrees from vertical plane when used for combustion product venting. Failure to do so will result in improper condensate drainage towards the boiler and possible subsequent vent pipe blockage.

- When flexible polypropylene pipe (liner) is used for combustion product venting, it must not be installed at an angle greater than 45 degrees from vertical plane. This will ensure proper condensate flow back towards the boiler.
- When flexible polypropylene pipe (liner) is used for combustion air supply to a boiler, the pipe (liner) can be installed in vertical or horizontal position.

4 Venting C. Polypropylene Venting (continued)

- g. Follow flexible polypropylene pipe (liner) manufacturer specific installation instructions regarding application/ listing, permits, minimum clearances to combustibles, installation details (proper joint assembly, pipe support and routing, gasket and fitting installation, optional tooling availability/usage, routing through masonry chimney for combustion product venting or, combination of combustion product venting and combustion air supply).

- h. When there is a conflict between flexible polypropylene pipe (liner) manufacturer installation instructions and these instructions, the more restrictive instructions shall govern.

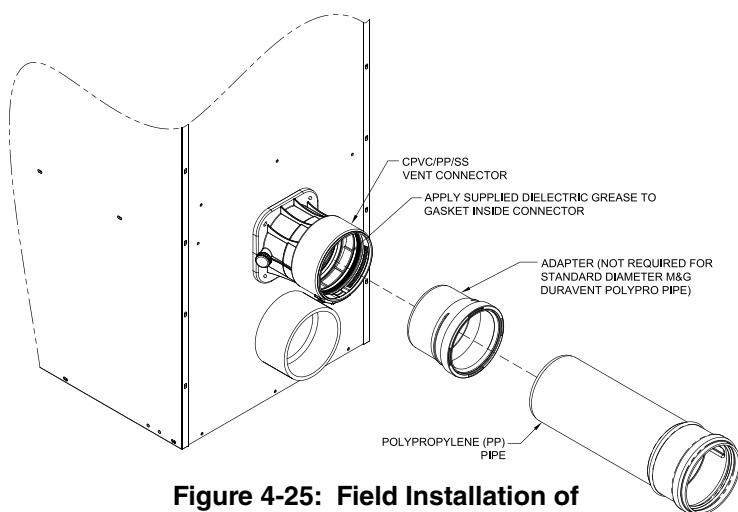

Figure 4-25: Field Installation of Polypropylene Vent Adapter

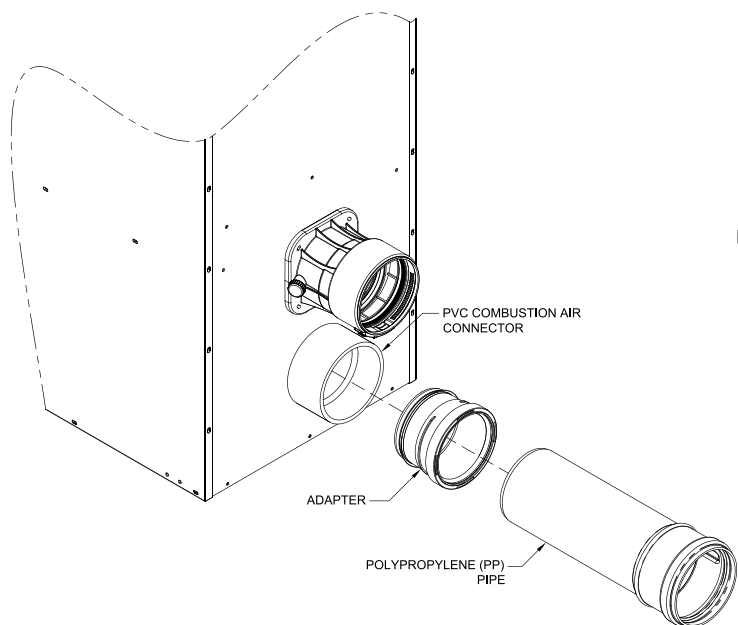

Figure 4-26: Field Installation of Polypropylene Combustion Air Adapter

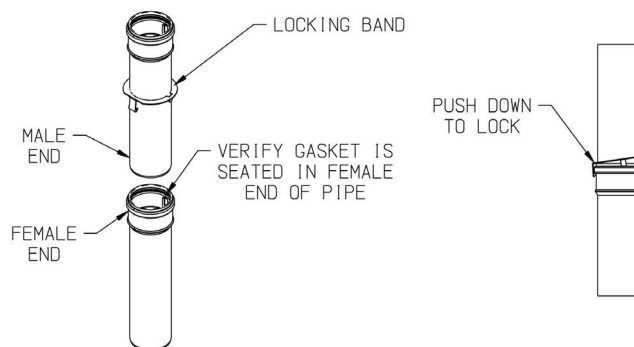

Figure 4-27: Locking Band Clamp Installation, M&G DuraVent or Centrotherm InnoFlue

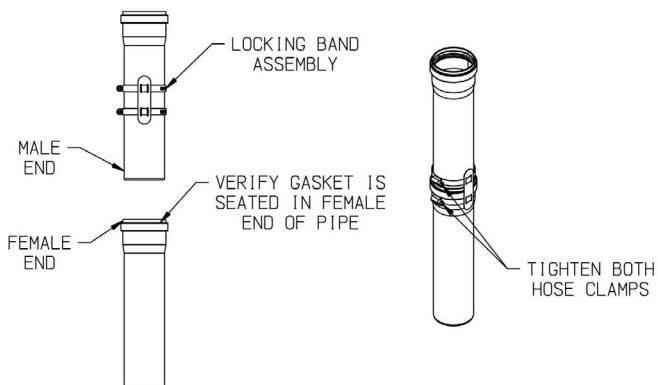
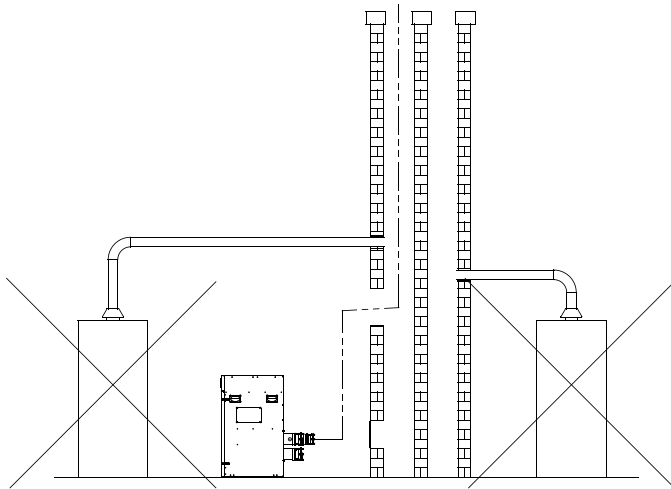

Figure 4-28: Alternate Locking Band Clamp Installation, M&G DuraVent

4 Venting C. Polypropylene Venting (continued)



Venting of Other Appliances (or Fireplace) into Chase or Adjacent Flues Prohibited!

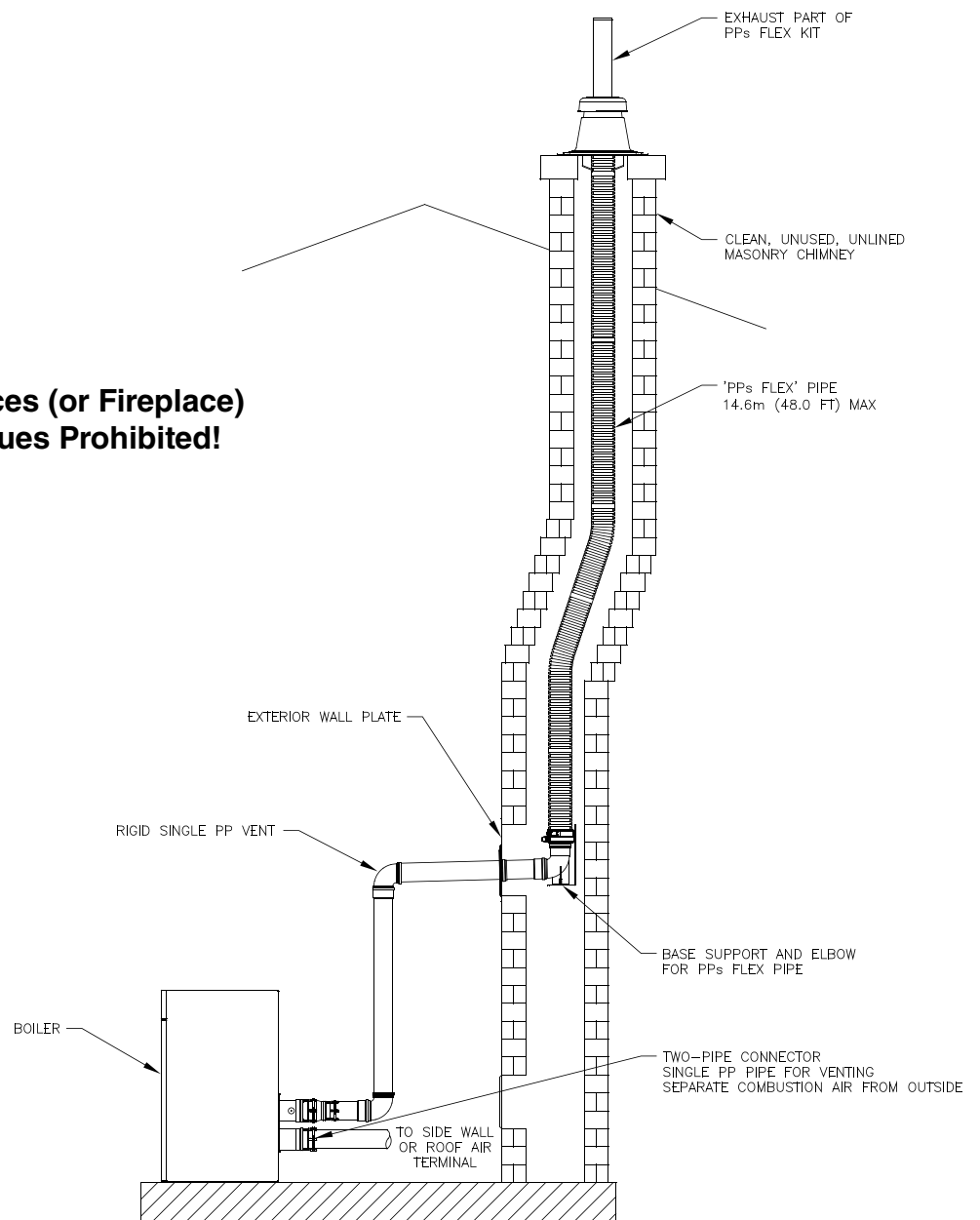

Figure 4-29: Flexible Vent in Masonry Chimney with Separate Combustion Air Intake

4 Venting *(continued)*

D. Stainless Steel Venting

WARNING

Asphyxiation Hazard. Follow these instructions and the installation instructions included by the original stainless steel venting component manufacturers, Heat Fab, M&G/DuraVent or Z-Flex, whichever applicable. Failure to do so could cause products of combustion to enter the building, resulting in severe property damage, personal injury or death. Where a conflict arises between Heat Fab, M&G/DuraVent or Z-Flex instructions and these instructions, the more restrictive instructions shall govern.

- Do not mix vent components from listed manufacturers.
- Examine all components for possible shipping damage prior to installation.
- All condensate that forms in the vent must be able to drain back to the boiler.

NOTICE: Do not exceed maximum vent/combustion air system length. Refer to “2. Vent/Combustion Air Piping” under “A. General Guidelines” in this section for maximum vent/combustion air system length. Use only vent and combustion air terminals and terminal locations shown in “3. Vent/Combustion Air Terminals” under “A. General Guidelines” of this section.

1. Components

- For use on models ALP399C and ALP500C, U.S. Boiler Company offers size 4 in. vent pipe and fittings shown in Table 4-30. It is the responsibility of the installing contractor to procure stainless steel vent system pipe and related components.

- Alternate listed stainless steel vent system manufacturers and components are shown in Tables 4-31 and 4-32.
- Where the use of “silicone” is called for in the following instructions, use GE RTV 106 or equivalent for the vent collar. Seal galvanized combustion air piping sections with any general-purpose silicone sealant such as GE RTV102. Seal PVC combustion air piping sections with PVC cement.
- Do not drill holes in vent pipe.

2. Field Installation of Stainless Steel Vent Adapter (see Figure 4-33).

- No adapter is required for stainless steel vent pipe unless vent diameter is reduced per Table 4-2. See Tables 4-30 through 4-32 for adapters for reduced vent diameter.

Table 4-30: U.S. Boiler Company (Heat Fab) Vent System Components (Stainless Steel, 4 in. only)

Component	Part Number, 4 in. (100 mm)
Boiler Adapter	no adapter required
Straight Pipe, 1 ft. (0.3 m)	100176-01
Straight Pipe, 3 ft. (0.9 m)	100177-01
Straight Pipe, 5 ft. (1.5 m)	100178-01
Straight Pipe, Adjustable 1.06-1.64 ft. (0.3 m to 0.5 m)	100179-01
90° Elbow	100180-01
45° Elbow	100181-01
Single Wall Thimble	100184-01

* **Note:** When using room air for combustion, use tee for sidewall vent termination.
Tee part number: 8116313 (4 in.).

Table 4-31: M&G DuraVent FasNSeal Stainless Steel Vent System Components, Single Wall

Boiler Model	Nominal Pipe Diameter	Boiler Adapter	Sidewall * or Roof Termination: Straight Termination w/Screen	Wall Thimble
ALP399C (reduced dia.) ALP500C (reduced dia.)	3 in. (80 mm)	FS0403TR	FSBS3	FSWT3
ALP399C (standard dia.) ALP500C (standard dia.) ALP600C (reduced dia. vent) ALP700C (reduced dia. vent) ALP800C (reduced dia. vent)	4 in. (100 mm)	ALP399C & ALP500C: No Adapter Required; ALP600C, ALP700C, ALP800C: FS0604TR	FSBS4	FSWT4
ALP600C (standard dia. vent) ALP700C (standard dia. vent) ALP800C (reduced dia. vent)	6 in. (150 mm)	No Adapter Required	FSBS6 (23° angle)	FSWT6

Note: When using room air for combustion, use tee for sidewall vent termination. Termination tee part numbers: FSTT3 (3 in.), FSTT4 (4 in.) FSTT6 (6 in.)

See M&G DuraVent FasNSeal literature for other required component part numbers such as straight pipe, elbows, firestops, and vent supports.

4 Venting D. Stainless Steel Venting (continued)

Table 4-32: Z-Flex, Z-Vent (SVE Series III, Z-Vent III) Stainless Steel Vent System Components, Single Wall

Boiler Model	Nominal Pipe Diameter	Boiler Adapter	Sidewall * or Roof Termination: Straight Termination w/Screen	Wall Thimble
ALP399C (reduced dia.) ALP500C (reduced dia.)	3 in. (80 mm)	2SVSR0403	2SVSTPX03	2SVSWTF03
ALP399C (standard dia.) ALP500C (standard dia.) ALP600C (reduced dia. vent) ALP700C (reduced dia. vent) ALP800C (reduced dia. vent)	4 in. (100 mm)	ALP399C & ALP500C: No Adapter Required; ALP600C, ALP700C, ALP800C: 2SVSR0604	2SVSTPX04	2SVSWTF04
ALP600C (standard dia. vent) ALP700C (standard dia. vent) ALP800C (standard dia. vent)	6 in. (150 mm)	No Adapter Required	2SVSTPX06	2SVSWTF06

* **Note:** When using room air for combustion, use 90° elbow or tee for sidewall vent termination. Termination elbow part numbers: 2SVSTEX0390 (3 in.), 2SVSTEX0490 (4 in.). Termination tee part numbers: 2SVSTTX03 (3 in.), 2SVSTTX04 (4 in.), 2SVSTTX06 (6 in.). See Z-Flex literature for other required component part numbers such as straight pipe, elbows, firestops, and vent supports.

- b. Install CPVC/PP/SS vent connector. Follow instructions in “2. Field Installation of CPVC/PP/SS Vent Connector” under “B. CPVC/PVC Venting”.
- c. Apply provided dielectric grease to gasket inside vent connector that will be in contact with adapter.
- d. Push and twist adapter into vent system connector until adapter bottoms out.
- e. Tighten clamp to secure adapter in CPVC/PP/SS vent connector.

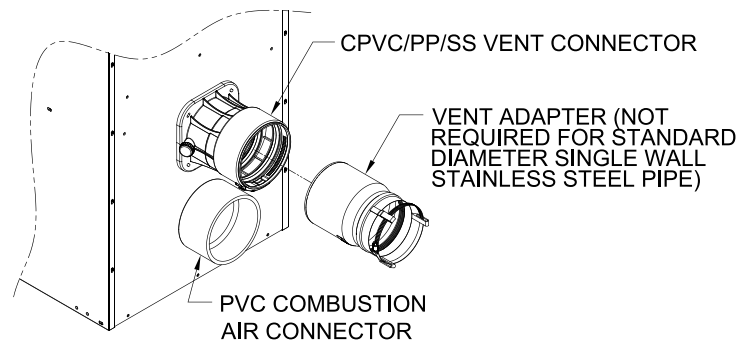

Figure 4-33: Field Installation of Stainless Steel Vent Adapter

3. System Assembly

WARNING

Asphyxiation Hazard. Vent systems made by Heat Fab, M&G / DuraVent and Z-Flex rely on gaskets for proper sealing. When these vent systems are used, take the following precautions:

- Make sure that gasket is in position and undamaged in the female end of the pipe.
- Make sure that both the male and female pipes are free of damage prior to assembly.
- Only cut vent pipe as permitted by the vent manufacturer in accordance with their Instructions. When pipe is cut, cut end must be square and carefully de-burred prior to assembly.
 - a. Plan venting system to avoid possible contact with plumbing or electrical wires. Start at vent connector at boiler and work towards vent termination.
 - b. Follow all manufacturer instructions and warnings when preparing pipe ends for joining and when assembling the vent/combustion air system.

NOTICE: The venting system must be free to expand and contract and supported in accordance with installation instructions included by the original stainless steel venting component manufacturers, Heat Fab, M&G / DuraVent or Z-Flex, whichever applicable.

- c. On horizontal pipe sections, orient all welded seams at the 12:00 position. Do not place longitudinal welded seams at the bottom of horizontal sections of vent pipe.
- d. Assemble the combustion air system using either galvanized or PVC pipe.
 - i. If PVC piping is used, use PVC cement to assemble the PVC intake system components. See “B. CPVC/PVC Venting” for combustion air pipe installation instructions.
 - ii. If galvanized piping is used, use at least two sheet metal screws per joint. Seal outside of all joints.

4 Venting D. Stainless Steel Venting *(continued)*

4. Horizontal Sidewall Vent Termination

a. Standard Two-Pipe Termination

See Figure 4-6.

i. Vent Termination

- Use components listed in Tables 4-30 through 4-32.

NOTICE: The joint between the terminal and the last piece of pipe must be outside of the building.

- Male end of terminal will fit into female end of any of the listed stainless vent systems.
- Apply a heavy bead of silicone to the male end of the terminal before inserting it into the last piece of pipe. Orient the terminal so that the seam in the terminal is at 12:00.
- Smooth the silicone over the seam between the terminal and the last piece of pipe, applying additional silicone if necessary to ensure a tight seal.
- Allow the silicone to cure per the silicone manufacturer's instructions before operating the boiler.

ii. Combustion Air Termination

- Use a 90° elbow directed downward.
- Install a screen in the inlet terminal. Use a screen having 1/2 in. x 1/2 in. (13 mm x 13 mm) mesh.

b. Optional Two-Pipe Snorkel Termination

See Figure 4-7.

This installation will allow a maximum of 7 ft. (2.1 m) vertical exterior run of the vent/combustion air piping to be installed on the approved AL29-4C stainless steel horizontal venting application.

i. Vent Termination

- After penetrating wall, install the appropriate manufacturer's 90° elbow so that the elbow leg is in the up direction.
- Install maximum vertical run of 7 ft. (2.1 m) of appropriate manufacturer's vent pipe as shown in Figure 4-7.
- At top of vent pipe length install another appropriate manufacturer's 90° elbow so that the elbow leg is opposite the building's exterior surface.
- Install horizontal vent terminal.

- Brace exterior piping if required.
- ##### ii. Combustion Air Termination
- After penetrating wall, install a 90° elbow so that the elbow leg is in the up direction.
 - Install maximum vertical run of 7 ft. (2.1 m) of combustion air pipe as shown in Figure 4-7.
 - At top of vent pipe length install another 90° elbow so that the elbow leg is opposite the building's exterior surface.
 - Install screen and horizontal vent terminal.
 - Brace exterior piping if required.

5. Vertical Vent Termination

a. Standard Two-Pipe Termination

See Figures 4-9 and 4-10.

i. Vent Termination

- Use the terminal supplied by the vent system manufacturer shown in Tables 4-30 through 4-32. Follow manufacturer's instructions to attach terminal to vent system.

ii. Combustion Air Termination

- Install vertical combustion air terminal. Vertical combustion air terminal consists of a 180° bend (comprised of two 90° elbows) as shown in Figure 4-9.
- Install screen in the combustion air terminal. Use a screen having 1/2 in. x 1/2 in. (13 mm x 13 mm) or larger mesh.

E. Optional Room Air for Combustion

1. General Guidelines

- Room air is optional for commercial applications. Room air uses one pipe to expel products of combustion directly outdoors with combustion air supplied from boiler room or enclosure. Direct vent is recommended for residential applications. Direct vent uses two pipes, one to expel products of combustion directly outdoors and one to supply combustion air to the boiler directly from outdoors. See preceding sections A through D for direct vent instructions.
- Avoid combustion air contaminants in the boiler room. See Table 3-1. Permanently remove any contaminants found in the boiler room. If contaminants cannot be removed, do not use room air for combustion.

4 Venting E. Optional Room Air for Combustion *(continued)*

WARNING

Sources of combustion air contaminants, including chlorines, chlorofluorocarbons (CFC's), petroleum distillates, detergents, volatile vapors or other chemicals must not be present in the boiler room. If any of these contaminants is present, severe boiler corrosion and failure will result.

2. Outdoor Openings to Boiler Room

a. Provide combustion and ventilation air to the boiler room or enclosure.

Follow the *National Fuel Gas Code*, ANSI Z223.1, or, in Canada, *Installation Code for Gas Burning Appliances and Equipment*, CGA Standard B149 Code as well as all applicable local codes. Use one of the following two methods.

b. Two Permanent Openings Method:

Provide two permanent openings, once within 12 in. (300 mm) of the top of the enclosure and one within 12 in. (300 mm) of the bottom of the enclosure. Openings must communicate directly, or by ducts, with the outdoors or spaces that freely communicate with the outdoors, as follows:

- i. Direct communication or through vertical ducts: minimum free area of each opening shall be 1 in.²/4,000 Btu/hr (550 mm²/kW) of total input rating of all appliances within the enclosure.
- ii. Horizontal ducts: minimum free area of each opening shall be 1 in.²/2,000 Btu/hr (1,100 mm²/kW) of total input rating of all appliances within the enclosure.

c. One Permanent Opening Method:

Provide one permanent opening, commencing within 12 in. (300 mm) of the top of the enclosure. The opening shall communicate through a vertical or horizontal duct to the outdoors or spaces that freely communicate with the outdoors and shall have a minimum free area of the following:

- i. 1 in.²/3,000 Btu/hr (700 mm²/kW) of total input rating of all appliances located within the enclosure.
 - ii. Not less than the sum of the areas of all vent connectors in the space.
- d. Motorized Louvers or Dampers: Motorized louvers or dampers must be interlocked with the boiler to allow ignition and firing of the burner only when louvers are in the fully-open position. Wire the interlock to the

Auto Reset External Limit connections. See Section 8 "Electrical".

3. Terminations

- a. For standard horizontal sidewall terminations, see Figures 4-1 and 4-2. When using room air for combustion, use 90° elbow or tee for sidewall vent termination.

NOTICE: Use 90° elbow or tee for horizontal sidewall vent termination when using room air for combustion.

- b. For vertical roof terminations, see Figures 4-9 and 4-10.

F. Removing the Existing Boiler

When an existing boiler is removed from a common venting system, the common venting system is likely to be too large for proper venting of the remaining appliances. At the time of removal of an existing boiler, the following steps shall be followed with each appliance remaining connected to the common venting system placed in operation, while the other appliances remaining connected to the common venting system are not in operation.

1. Seal any unused openings in the common venting system.
2. Visually inspect the venting system for proper size and horizontal pitch and determine there is no blockage or restriction, leakage, corrosion, and other deficiencies which could cause an unsafe condition.
3. Insofar as is practical, close all building doors and windows and all doors between the space in which the appliances remaining connected to the common venting system are located and other spaces of the building. Turn on clothes dryers and any appliance not connected to the common venting system. Turn on any exhaust fans, such as range-hoods and bathroom exhausts, so they will operate at maximum speed. Do not operate a summer exhaust fan. Close fireplace dampers.
4. Place in operation the appliance being inspected. Follow the Lighting (or Operating) Instructions. Adjust thermostat so appliance will operate continuously.
5. Test for spillage at the draft hood relief opening after 5 minutes of main burner operation. Use the flame of a match or candle, or smoke from a cigarette, cigar or pipe.

4 Venting F. Removing the Existing Boiler (continued)

6. After it has been determined that each appliance remaining connected to the common venting system properly vents when tested as outlined above, return doors, windows, exhaust fans, fireplace dampers and any other gas burning appliance to their previous conditions of use.
7. Any improper operation of the common venting system should be corrected so the installation conforms with the *National Fuel Gas Code*, ANSI Z223.1/NFPA 54 and/or the *Natural Gas and Propane Installation Code*, CAN/CSA B149.1. When resizing any portion of the common venting system, the common venting system should be resized to approach the minimum size as determined using the appropriate tables in Part II in the *National Fuel Gas Code*, ANSI Z223.1/NFPA 54 and/or the *Natural Gas and Propane Installation Code*, CAN/CSA B149.1.

Au moment du retrait d'une chaudière existante, les mesures suivantes doivent être prises pour chaque appareil toujours raccordé au système d'évacuation commun et qui fonctionne alors que d'autres appareils toujours raccordés au système d'évacuation ne fonctionnent pas:

1. Sceller toutes les ouvertures non utilisées du système d'évacuation.
2. Inspecter de façon visuelle le système d'évacuation pour déterminer la grosseur et l'inclinaison horizontale qui conviennent et s'assurer que le système est exempt d'obstruction, d'étranglement, de fuite, de corrosion et autres défaillances qui pourraient présenter des risques.
3. Dans la mesure du possible, fermer toutes les portes et les fenêtres du bâtiment et toutes les portes entre l'espace où les appareils toujours raccordés au système d'évacuation sont installés et les autres espaces du bâtiment. Mettre en marche les sècheuses, tous les appareils non raccordés au système d'évacuation commun et tous les ventilateurs d'extraction comme les hottes de cuisinière et les ventilateurs des salles de bain. S'assurer que ces ventilateurs fonctionnent à la vitesse maximale. Ne pas faire fonctionner les ventilateurs d'été. Fermer les registres des cheminées.
4. Mettre l'appareil inspecté en marche. Suivre les instructions d'allumage. Régler le thermostat de façon que l'appareil fonctionne de façon continue.

5. Faire fonctionner le brûleur principal pendant 5 min ensuite, déterminer si le coupe-tirage déborde à l'ouverture de décharge. Utiliser la flamme d'une allumette ou d'une chandelle ou la fumée d'une cigarette, d'un cigare ou d'une pipe.
6. Une fois qu'il a été déterminé, selon la méthode indiquée ci-dessus, que chaque appareil raccordé au système d'évacuation est mis à l'air libre de façon adéquate. Remettre les portes et les fenêtres, les ventilateurs, les registres de cheminées et les appareils au gaz à leur position originale.
7. Tout mauvais fonctionnement du système d'évacuation commun devrait être corrigé de façon que l'installation soit conforme au *National Fuel Gas Code*, ANSI Z223.1/NFPA 54 et (ou) aux codes d'installation CAN/CSA-B149.1. Si la grosseur d'une section du système d'évacuation doit être modifiée, le système devrait être modifié pour respecter les valeurs minimales des tableaux pertinents de l'appendice F du *National Fuel Gas Code*, ANSI Z223.1/NFPA 54 et (ou) des codes d'installation CAN/CSA-B149.1.

G. Multiple Boiler Installation Venting

1. Vent Piping and Terminations

- a. Multiple boiler vent terminations are shown in Figure 4-34.
- b. Each individual boiler must have its own vent pipe and vent terminal. Refer to Paragraphs A through F (as applicable) for individual boiler vent guidelines and options.

WARNING

Asphyxiation Hazard. No common manifold venting (vent piping and vent terminals) is permitted.

- c. Do not exceed the individual boiler maximum vent length listed in Table 4-2.
- d. For horizontal sidewall terminations, maintain at least 12 in. (300 mm) minimum horizontal distance between any adjacent individual boiler vent terminations. Additional horizontal spacing between any adjacent individual boiler vent terminations as well as extending the distance from building surfaces to vent termination end are recommended to avoid frost damage to building surfaces where vent terminations are placed.

4 Venting G. Multiple Boiler Installation Venting *(continued)*

NOTICE: Installing multiple individual boiler vent terminations too close together may result in combustion product water vapor condensation on building surfaces, where vent terminations are placed, and subsequent frost damage. To avoid/minimize frost damage, extend the distance from building surfaces to vent termination end and increase the horizontal distance between adjacent vent terminations.

- e. Individual boiler sidewall vent terminals must be placed at least 12 in. (300 mm) [18 in. (460 mm) in Canada] above the ground plus the expected snow accumulation.
- f. Multiple individual boiler vertical vent pipes may be piped through a common conduit or chase so that one roof penetration may be made.
- g. For vertical roof terminations, maintain at least 12 in. (300 mm) minimum horizontal distance between adjacent individual boiler vent terminations.

2. Combustion Air Piping

- a. Multiple boiler combustion air terminations are shown in Figure 4-34.
- b. Each individual boiler must have own combustion air pipe and terminal. Refer to Paragraphs A through F (as applicable) for individual boiler combustion air guidelines and options.
- c. Do not exceed the individual boiler maximum combustion air pipe length listed in Table 4-2.
- d. If possible, locate vent and combustion air terminals for an individual boiler on the same wall to prevent nuisance shutdowns. If not, an individual boiler may be installed with a roof vent terminal and sidewall combustion air terminal.

4 Venting G. Multiple Boiler Installation Venting (continued)

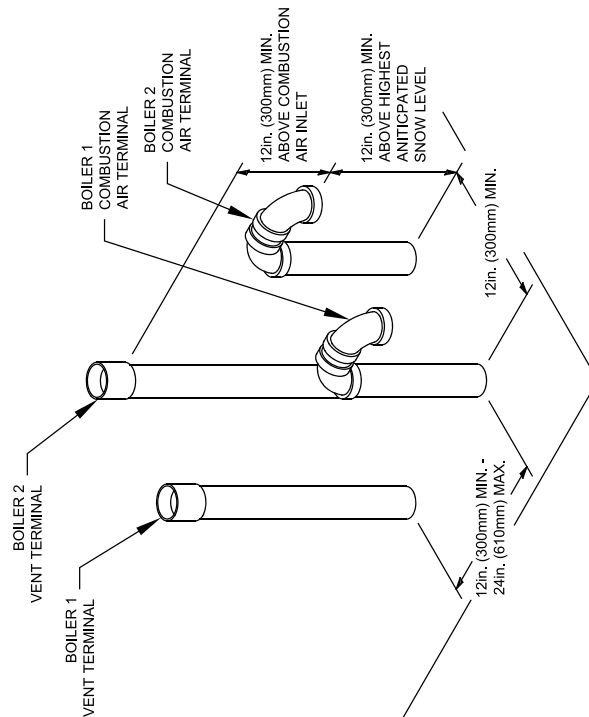
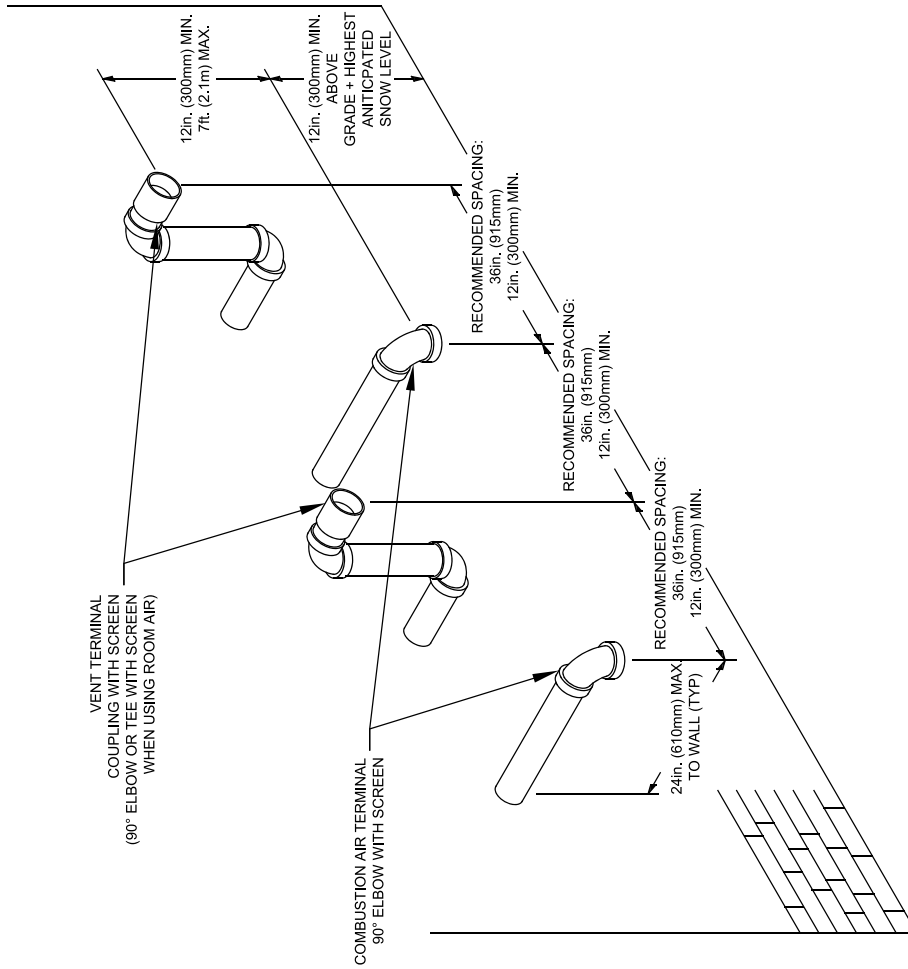

Figure 4-34: Multiple Boiler Direct Vent Termination

5 Condensate Disposal

A. Condensate Trap and Drain Line

1. All condensate which forms in the boiler or vent system collects in the sump under heat exchanger and leaves the boiler through factory installed condensate trap.
2. The trap allows condensate to drain from sump while retaining flue gases in the boiler. The trap has factory installed overflow switch, which shuts down the boiler in the event the drain line becomes obstructed, preventing proper condensate removal. Refer to Section 11 "Service and Maintenance" for condensate trap and condensate overflow switch removal and replacement procedure, if required.
3. Note the following when disposing of the condensate:
 - a. Condensate is slightly acidic, typical pH around 3.5 - 4.5. Do not use metallic pipe or fittings in the condensate drain line. Do not route the drain line through areas that could be damaged by leaking condensate.
 - b. Do not route or terminate the condensate drain line in areas subject to freezing temperatures.
 - c. If the point of condensate disposal is above the trap, a condensate pump is required to move the condensate to the drain. Select a condensate pump approved for use with condensing furnaces. If overflow from the pump would result in property damage, select a pump with an overflow switch. Wire this switch in series with installer provided external high limit, to shut off the boiler, and, if desired, in series with installer-supplied alarm, to trigger an alarm in the event of overflow.
 - d. Do not attempt to substitute another trap for one provided with the boiler.
 - e. In order for boiler to work properly, the boiler must be leveled during installation.
4. The condensate trap connection is located at boiler left side, below inlet and outlet water pipe connections. Refer to Figures 1-1, through 1-3 and 5-2.
5. Condensate trap must be filled up with water, prior to boiler start-up and before connecting any condensate line to the boiler to ensure combustion products cannot escape from operating boiler. To fill the trap, inject water in the amount of 1 cup (240 ml) through condensate trap connection. Do not overfill the trap.

6. Install tee for condensate overflow and vent as shown in Figure 5-2.

WARNING

Asphyxiation Hazard. Failure to fill the condensate trap with water prior to boiler start-up could cause flue gas to enter the building, resulting in personal injury or death.

7. If any additional condensate drain line is needed, construct the extension from PVC or CPVC Schedule 40 pipe. The factory supplied $\frac{3}{4}$ in. x 5-5/8 in. long PVC coupling, located in the miscellaneous parts carton, must be used to connect drain line to the condensate trap. Do not over tighten coupling compression nuts when connecting drain line and condensate trap.

Table 5-1: Maximum Condensate Flow

Boiler Model	*Maximum Condensate Flow, GPH
ALP399C	4.5
ALP500C	5.6
ALP600C	7.0
ALP700C	8.1
ALP800C	9.0

*Assumes 100% of water in fuel condenses.

8. Size condensate drain line, pump and neutralizer (if using other than manufacturer neutralizer kit) to accommodate maximum condensate flow shown in Table 5-1 "Maximum Condensate Flow".

WARNING

Asphyxiation Hazard. Failure to install the condensate drain in accordance with the above instructions could cause flue gas to enter the building, resulting in personal injury or death.

NOTICE: Boiler condensate is corrosive. Route condensate drain line in a manner such that any condensate leakage will not cause property damage.

- Some jurisdictions may require that condensate be neutralized prior to disposal.
- Use materials approved by the authority having jurisdiction.

5 Condensate Disposal *(continued)*

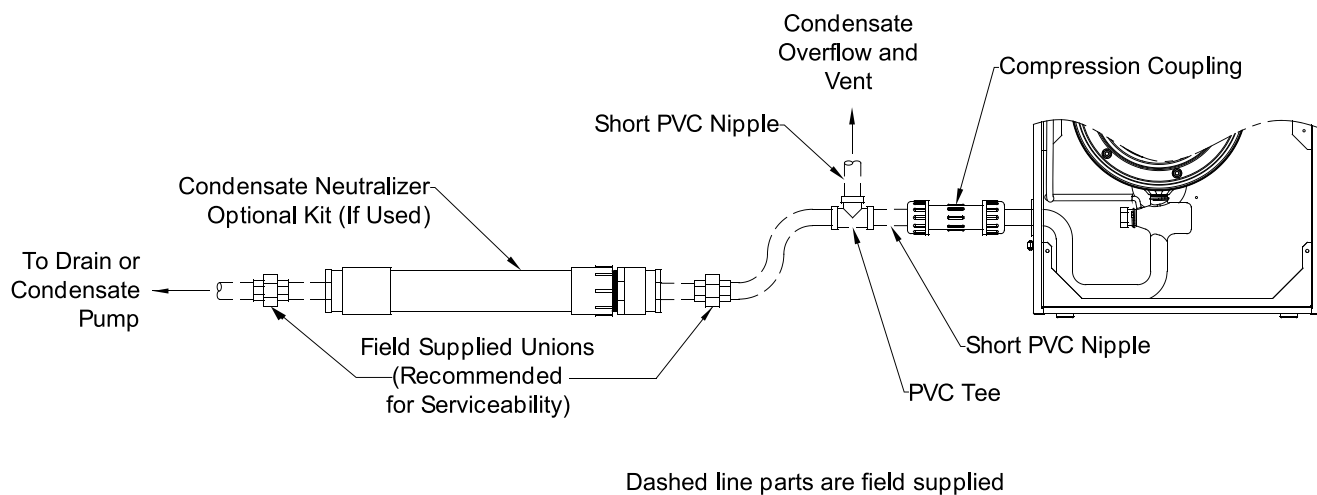

Figure 5-2: Condensate Trap and Drain Line

B. Condensate Neutralizer Installation

1. Some jurisdictions may require that the condensate be neutralized before being disposed of. Follow local codes pertaining to condensate disposal.
2. A condensate neutralizer kit (P/N 101867-01) is available as optional equipment. Follow local codes and instructions enclosed with the kit for condensate neutralizer installation.
3. Limestone chips will get coated by neutral salts (product of chemical reaction between limestone and acidic condensate) and lose neutralizing effectiveness over time. Therefore, periodic condensate neutralizer maintenance and limestone chip replacement must be performed. A pH test or acid test kits are available from HVAC/plumbing distributors and should be used to measure condensate acidity before/after neutralizer thus indicating a need for service and chip replacement.

6 Water Piping and Trim

NOTICE: Failure to properly pipe boiler may result in improper operation and damage to boiler or structure.

- Install boiler so that the gas ignition system components are protected from water (dripping, spraying, rain, etc.) during appliance operation and service (circulator replacement, etc.).
- Oxygen contamination of boiler water will cause corrosion of iron and steel boiler components, and can lead to boiler failure. U.S. Boiler Company's Standard Warranty does not cover problems caused by oxygen contamination of boiler water or scale (lime) build-up caused by frequent addition of water.
- Do not fill boiler with softened water to prevent chloride contamination.
- Installation is not complete unless a safety relief valve is installed into the tapping located on left side of appliance or the supply piping.

A. Installation of Factory Supplied Piping and Trim Components

1. Install provided components per Figure 6-2 for ALP399C or Figure 6-6 for ALP500C through ALP800C. Rear tapping is return/inlet. Front tapping (middle on ALP399C) is supply/outlet. Piping and trim components are located in miscellaneous parts carton shipped with the boiler.

- a. Safety Relief Valve – Install on tee off 3/4 in. NPT tapping on ALP399C or on tee off supply tapping on ALP500C through ALP800C. Use provided 10 in. long nipple to locate valve above heat exchanger top.

- b. Drain Valve – Install on tee off 3/4 in. NPT tapping on ALP399C or on tee off supply tapping on ALP500C through ALP800C.
- c. Temperature and Pressure Gauge – Install on supply piping.
- d. Flow Switch – Install on supply piping. Use provided tee with 1 in. NPT outlet. Use correct paddle per Table 6-1. Refer to Section 8 “Electrical” for flow switch wiring.
- e. Install drain valve into tee bottom outlet.

Table 6-1: Flow Switch Paddle Application

Boiler	Flow Switch Paddle Marking
ALP399C	1
ALP500C	E
ALP600C	3
ALP700C	1
ALP800C	1

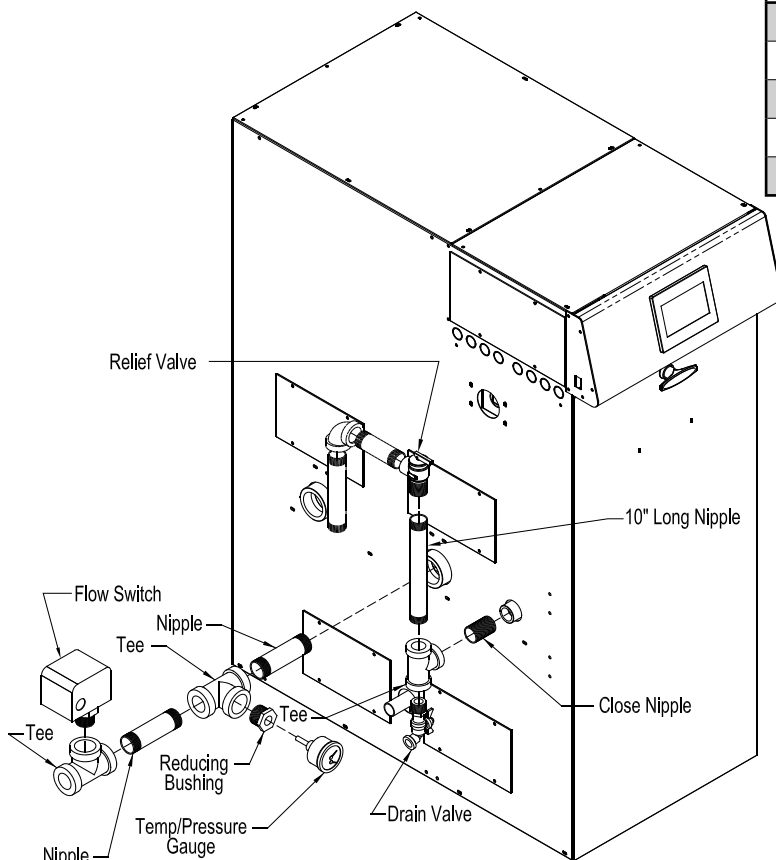

Figure 6-2: Factory Supplied Piping and Trim Installation - ALP399C

6 Water Piping and Trim *(continued)*

B. Piping System To Be Employed.

Alpine boilers are designed to operate in a closed loop pressurized system. Minimum pressure in the boiler must be 14.5 psi (100 kPa). Proper operation of the Alpine boiler requires that the water flow through the boiler remain within the limits shown in Table 6-3 any time the boiler is firing.

NOTICE: Failure to maintain the flow through boiler within specified limits could result in erratic operation or premature boiler failure.

1. Near boiler piping must isolate Alpine boiler

from system piping via closely spaced tees to ensure specified flow range through boiler any time the boiler is firing.

- The flow rate through the isolated near-boiler loop is maintained by installer supplied boiler circulator. See Tables 6-4 and 6-5 for recommended circulators.
- The flow rate through the isolated near-boiler loop is completely independent of the flow rate through the heating system loop(s).
- The flow rate through the heating system loop(s) is controlled by installer sized/provided system loop circulator(s).
- This piping arrangement can be used either for space heating-only applications or space heating with indirect water heater(s) applications.
 - Space heating only - refer to Tables 6-4 and 6-5 and Figure 6-9 “Near Boiler Piping - Heating Only” as applicable.

- Space heating plus indirect water heater(s) – refer to Tables 6-4 and 6-5 and Figure 6-10 “Near Boiler Piping - Heating Plus Indirect Water Heater” as applicable.
- If piping indirect water heater off boiler (see Figure 6-10), be sure that indirect water heater and domestic hot water circulator are sized to maintain flow through boiler within limits shown in Table 6-3.

NOTICE: Where it is not possible to install a separate boiler loop, the system circulator must be sized to ensure that the flow through boiler stays within the defined parameters to prevent overheating when the boiler is fired at its full rated input. Install a flow meter to measure the flow, or fire the boiler at full rate and ensure the boiler DT does not exceed 35°F (19°C).

2. Direct connection of Alpine boiler to heating system, similar to a conventional boiler, is NOT RECOMMENDED because:

- The flow rate through system must be the same as through boiler and fall within limits specified in Table 6-3.
- Pressure drop through entire system must be known, added to pressure drop through boiler, and a circulator selected to provide required flow at total calculated pressure drop.
- It is often very difficult to accurately calculate the pressure drop through the system.
- In replacement installations, it may be nearly impossible to get an accurate measurement of piping amount and number of fittings in the system. If system is zoned, the system flow rate may drop well below recommended minimum flow when only a single zone is calling for heat.

Table 6-3: Flow Range Requirement Through Boiler

Boiler Model	Supply Connection (in.)	Return Connection (in.)	DT= 35°F		ΔT = 30°F		ΔT = 25°F		ΔT = 20°F	
			Minimum Required Flow (GPM)	Boiler Head Loss (ft.)	Required Flow (GPM)	Boiler Head Loss (ft.)	Required Flow (GPM)	Boiler Head Loss (ft.)	Maximum Required Flow (GPM)	Boiler Head Loss (ft.)
ALP399C	1-1/2	1-1/2	21.5	6.1	25.1	7.9	30.2	10.8	37.7	15.9
ALP500C	2	2	27.7	5.2	32.3	6.8	38.8	9.3	48.5	13.6
ALP600C	2	2	33.9	4.7	39.6	6.1	47.5	8.4	59.4	12.4
ALP700C	2	2	39.4	6.0	45.9	7.9	55.1	10.9	68.9	16.1
ALP800C	2	2	43.4	5.9	50.7	7.8	60.8	10.8	76.0	16.1

Notes: Required Flow = Output*1000/(500*ΔT), where flow rate is in GPM, output is in MBH, and ΔT is in °F.

Outputs for specific boiler models are provided in Table 1-4. See also Tables 6-4 and 6-5 for near boiler piping sizing. Using boiler antifreeze will result in increased fluid density and may require larger circulators.

6 Water Piping and Trim *(continued)*

Table 6-4: Recommended Taco Circulators for 50 ft. Equivalent ft. Near Boiler Piping [Approximately 20 ft. Straight Pipe, (4) 90° Elbows, and (2) Full Port Ball Valves]

Boiler Model	Supply & Return Connection (in.)	Near Boiler Pipe Size (in.)	DT=35°F			DT=30°F			DT=25°F			DT=20°F		
			Flow (GPM)	Boiler & Piping Head Loss (ft.)	Circulator Model	Flow (GPM)	Boiler & Piping Head Loss (ft.)	Circulator Model	Flow (GPM)	Boiler & Piping Head Loss (ft.)	Circulator Model	Flow (GPM)	Boiler & Piping Head Loss (ft.)	Circulator Model
ALP399C	1½	2	21.4	6.4	0014	25.0	8.3	0013	30.0	11.4	2400-60	37.5	16.8	2400-70
ALP500C	2	2	27.7	5.8	0012	32.3	7.5	2400-60	38.8	10.3	2400-60	48.5	15.2	2400-65
ALP600C	2	2	33.9	5.5	2400-60	39.6	7.2	2400-60	47.5	9.9	2400-65	59.4	14.7	2400-70
ALP700C	2	2	39.4	7.1	2400-60	45.9	9.4	2400-65	55.1	12.9	2400-65	68.9	19.1	1935
ALP800C	2	2½	43.4	6.4	2400-60	50.7	8.5	2400-65	60.8	11.8	2400-65	76.0	17.6	1935

Table 6-5: Recommended Grundfos Circulators for 50 Equivalent ft. Near Boiler Piping [Approximately 20 ft. Straight Pipe, (4) 90° Elbows, and (2) Full Port Ball Valves]

Boiler Model	Supply & Return Connection (in.)	Near Boiler Pipe Size (in.)	DT=35°F			DT=30°F			DT=25°F			DT=20°F		
			Flow (GPM)	Boiler & Piping Head Loss (ft.)	Circulator Model	Flow (GPM)	Boiler & Piping Head Loss (ft.)	Circulator Model	Flow (GPM)	Boiler & Piping Head Loss (ft.)	Circulator Model	Flow (GPM)	Boiler & Piping Head Loss (ft.)	Circulator Model
ALP399C	1½	2	21.5	6.4	UP26-64F	25.1	8.4	UP26-99F	30.2	11.5	UPS43-100F, Spd. 2	37.7	16.9	UPS43-100F, Spd. 3
ALP500C	2	2	27.7	5.8	UPS43-44FC, Spd. 2	32.3	7.5	UPS43-44F	38.8	10.3	UPS43-100F, Spd. 2	48.5	15.2	UPS50-60F, Spd. 3
ALP600C	2	2	33.9	5.5	UPS43-44FC, Spd. 3	39.6	7.2	UPS43-100F, Spd. 2	47.5	9.9	UPS50-60F, Spd. 2	59.4	14.7	UPS40-80/2, Spd. 3
ALP700C	2	2	39.4	7.1	UPS43-100F, Spd. 2	45.9	9.4	UPS43-100F, Spd. 3	55.1	12.9	UPS50-60F, Spd. 3	68.9	19.1	UPS50-80/2, Spd. 3
ALP800C	2	2½	43.4	6.4	UPS43-100F, Spd. 2	50.7	8.5	UPS43-100F, Spd. 3	60.8	11.8	UPS50-60F, Spd. 3	76.0	17.6	UPS50-80/2, Spd. 3

6 Water Piping and Trim (continued)

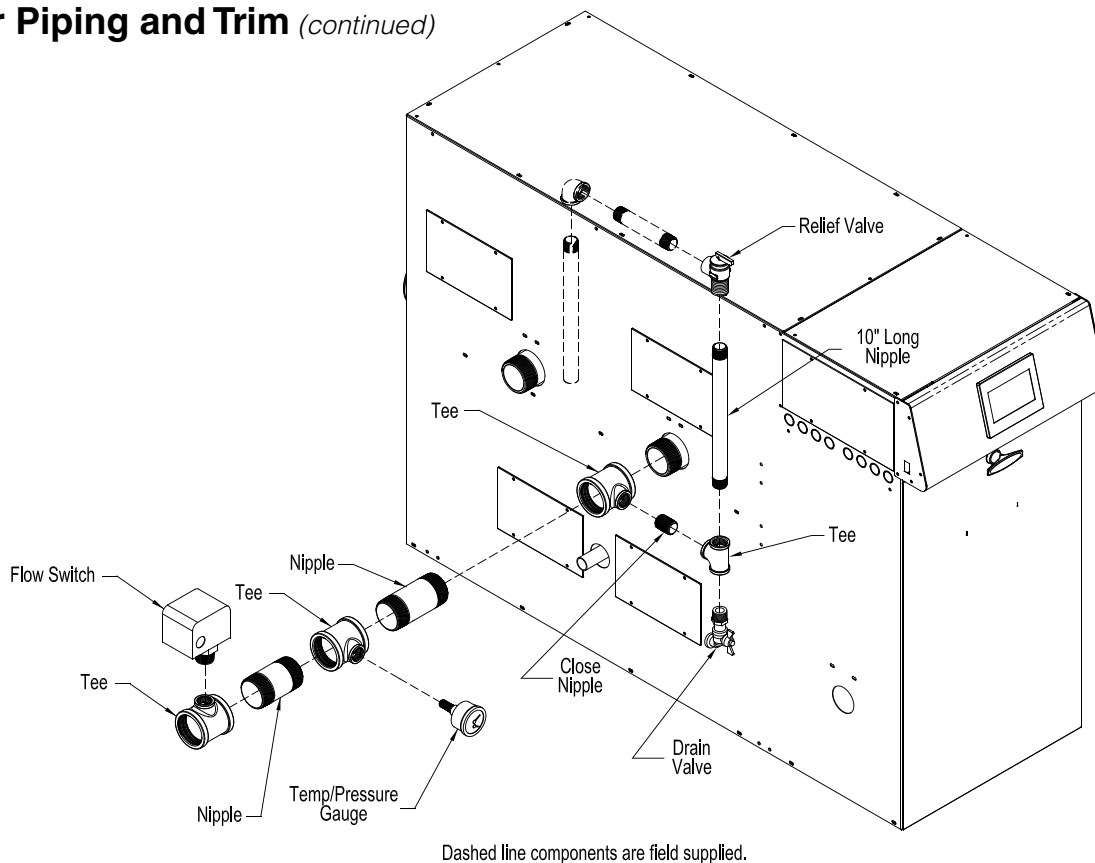

Figure 6-6: Factory Supplied Piping and Trim Installation - ALP500C, ALP600C, ALP700C and ALP800C

C. Standard Installation Requirements.

Observe the following guidelines when making the actual installation of the boiler piping:

1. Safety Relief Valve (Required) – The safety relief valve is packaged loose with boiler and must be installed in the location shown in Figure 6-2 or 6-6 “Factory Supplied Piping and Trim Installation”. The safety relief valve must be installed with spindle in vertical position. Installation of the safety relief valve must comply with ASME Boiler and Pressure Vessel Code, Section IV. The standard factory shipped safety relief valve is set at 50 psi (340 kPa) on ALP399C and ALP500C and 60 psi (410 kPa) on ALP600C, ALP700C and ALP800C. Optional 80 psi (550 kPa) and 100 psi (689 kPa) safety relief valve kits are available. If the safety relief valve is to be replaced, the replacement valve must have a relief capacity equal or exceeding the minimum relief valve capacity shown on the heat exchanger ASME plate. Also, when replacing the safety relief valve, verify the temperature and pressure gage meets ASME requirements for the replacement safety relief valve. Pipe the safety relief valve discharge to a location where hot water or steam will not create hazard or property damage if the valve opens.

The end of the discharge pipe must terminate in an unthreaded pipe. If the safety relief valve is not piped to a drain, it must terminate at least 6 in. (150 mm) above the floor. Do not run safety relief valve discharge piping through an area prone to freezing. The termination of discharge piping must be in an area where it will not become plugged by debris.

⚠ CAUTION

Burn Hazard. Safety relief valve discharge piping must be piped such that the potential of severe burns is eliminated. DO NOT pipe in any area where freezing could occur. DO NOT install any shut-off valves, plugs or caps. Consult local codes for proper discharge piping arrangement.

2. Flow Switch (Required) – A flow switch is required in lieu of manual reset low water cutoff (LWCO) for forced circulation coil-type water boilers to prevent overheating and heat exchanger failure in accordance with requirements of ASME Boiler and Pressure Vessel Code, Section IV, and ANSI/ASME CSD-1 – latest edition, “Controls and Safety Devices for Automatically Fired Boilers”.

6 Water Piping and Trim *(continued)*

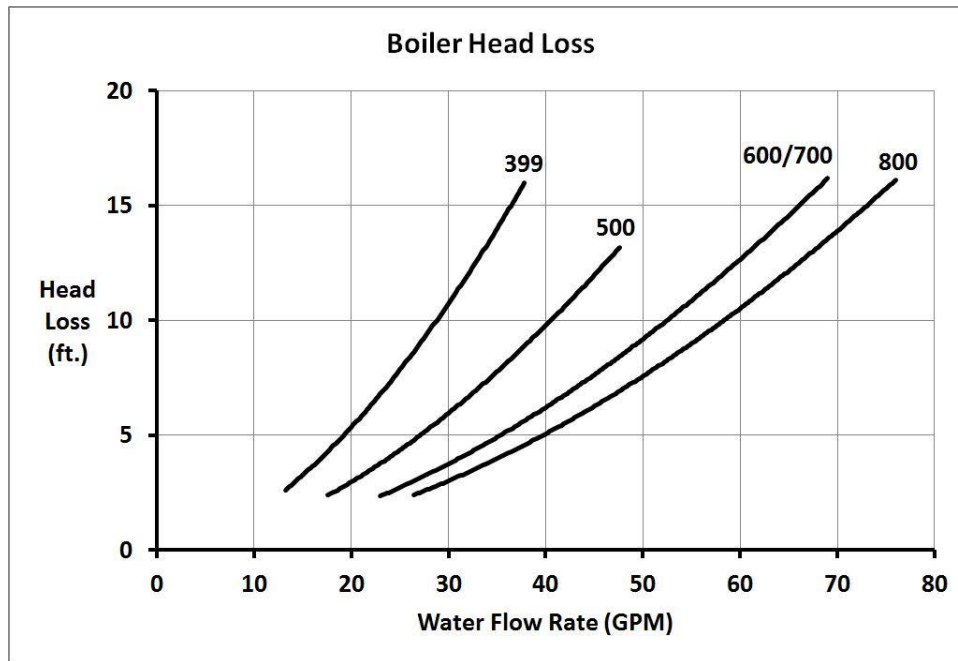

Figure 6-7: Boiler Head Loss

The flow switch is factory provided. Follow Section 6, Paragraph A and Section 8 'Electrical' of these instructions to install and wire the flow switch.

3. **Circulator (Required)** – Usually at least two circulators will be required to properly install an Alpine boiler. See Paragraph B above for information on sizing the circulators.
4. **Expansion Tank (Required)** – If this boiler is replacing an existing boiler with no other changes in the system, the old expansion tank can generally be reused. If the expansion tank must be replaced, consult the expansion tank manufacturer's literature for proper sizing.
5. **Fill Valve (Required)** – Either manual (recommended) or automatic fill valve may be used. However, if automatic refill is employed, a water meter must be added to evaluate the makeup water volume taken after initial fill and eliminate any water leakage as early as possible.
6. **Automatic Air Vent (Required)** – At least one automatic air vent is required. Manual vents will usually be required in other parts of the system to remove air during initial fill.
7. **Manual Reset High Limit** - Alpine boilers have factory provided UL353 listed boiler control and UL1434 listed manual reset high limit. An optional manual reset external high limit is available from U.S. Boiler Company to meet local code requirements.

8. **Y-strainer (Recommended)** – A Y-strainer or equivalent strainer removes heating system debris from hydronic systems and protects boiler heat exchanger from fouling. Install the strainer downstream of full port isolation valve at the inlet side of the circulator for easy service.
9. **Flow Control Valve (Strongly Recommended)** – The flow control valve prevents flow through the system unless the circulator is operating. Flow control valves are used to prevent gravity circulation or "ghost flows" in circulator zone systems through zones that are not calling for heat.
10. **Isolation Valves (Strongly Recommended)** – Isolation valves are useful when the boiler must be drained, as they will eliminate having to drain and refill the entire system.
11. **Drain Valve (Required)** – Drain valve is packaged loose with boiler and must be installed in the location shown in Figure 6-2 or 6-6 "Factory Supplied Piping and Trim Installation".
12. **An optional LWCO with manual reset** is available from U.S. Boiler Company to meet local code requirements.

6 Water Piping and Trim *(continued)*

Table 6-8: Fitting and Valve Equivalent Length

Copper Fitting and Sweat Valve Equivalent Length (ft.)				
Fitting or Valve Description	Copper Pipe or Valve Size			
	1	1¼	1½	2
90° Elbow	2.5	3.0	4.0	5.5
45° Elbow	1.0	1.2	1.5	2.0
Tee (through flow)	0.5	0.6	0.8	1.0
Tee (Branch flow)	4.5	5.5	7.0	9.0
Diverter Tee (typical)	23.5	25.0	23.0	23.0
Gate Valve	0.3	0.4	0.5	0.7
Globe Valve	25.0	36.0	46.0	56.0
Angle Valve	5.3	7.8	9.4	12.5
Ball Valve (standard port)	4.3	7.0	6.6	14.0
Ball Valve (full port)	1.9	1.4	2.2	1.3
Swing Check Valve	4.5	5.5	6.5	9.0
Flow-Check Valve (typical)	54.0	74.0	57.0	177.0
Butterfly Valve	2.7	2.0	2.7	4.5

Table 6-8: Fitting and Valve Equivalent Length (cont'd)

Threaded Fitting and Valve Equivalent Length (ft.)				
Fitting or Valve Description	Black Threaded Pipe or Valve Size			
	1	1¼	1½	2
90° Elbow	2.6	3.5	4.0	5.2
Long Radius Elbow (45° or 90°)	1.4	1.8	2.2	2.8
Tee (through flow)	1.8	2.3	2.7	3.5
Tee (Branch flow)	5.3	6.9	8.1	10.0
Close Return Bend	4.4	5.8	6.7	8.6
Gate Valve (full open)	0.7	0.9	1.1	1.4
Globe Valve (full open)	30.0	39.0	46.0	59.0
Angle Valve (full open)	13.0	17.0	20.0	26.0
Swing Check Valve (full open)	8.7	12.0	13.0	17.0
Flow-Check Valve (typical)	42.0	60.0	63.0	83.0

NOTE: Table 6-8 is provided as reference to assist in piping design and specifies equivalent length of typical piping fittings and valves.

NOTICE: The Alpine boiler heat exchanger is made from stainless steel tubular coil having relatively narrow waterways. Once filled with water, it will be subject to the effects of corrosion. Failure to take the following precautions to minimize corrosion and heat exchanger waterways overheating could result in severe boiler damage.

- Before connecting the boiler, ensure the system is free of impurities, grease, sediment, construction dust, sand, copper dust, flux and any residual boiler water additives. Flush the system thoroughly and repeatedly, if needed, with clear water mixed with concentrated rinse agent to remove these contaminants completely.
- Iron oxide (red oxide sludge Fe_2O_3) is produced during oxygenation. To minimize any oxygen presence in the system, the system must be air free and leak tight. Do not connect the boiler to radiant tubing without an oxygen barrier. Using automatic water refill is not recommended, however, if such refill is employed, a water meter must be added to evaluate the makeup water volume taken after initial fill and eliminate any water leakage as early as possible.
- Maintain the water pressure in the boiler at a minimum of 14.50 psi (100 kPa).
- The boiler water pH must be within between 7.5 and 9.5. If the system contains any aluminum components, pH must be less than 8.5.
- Black oxide sludge (magnetite Fe_3O_4) forms as the result of continuous electrolytic corrosion in any system not protected by an inhibitor.
- Scale deposit is made up of lime scale contained in most distributed water and settles over the warmest surfaces of boiler heat exchanger causing subsequent overheating and eventual failure. Water hardness must be maintained within 3 to 9 grain/gal range.
- Refer to Section 11 "Service and Maintenance" for recommended heating system water treatment products (corrosion/scale inhibitors, cleaners etc) and their suppliers.

6 Water Piping and Trim (continued)

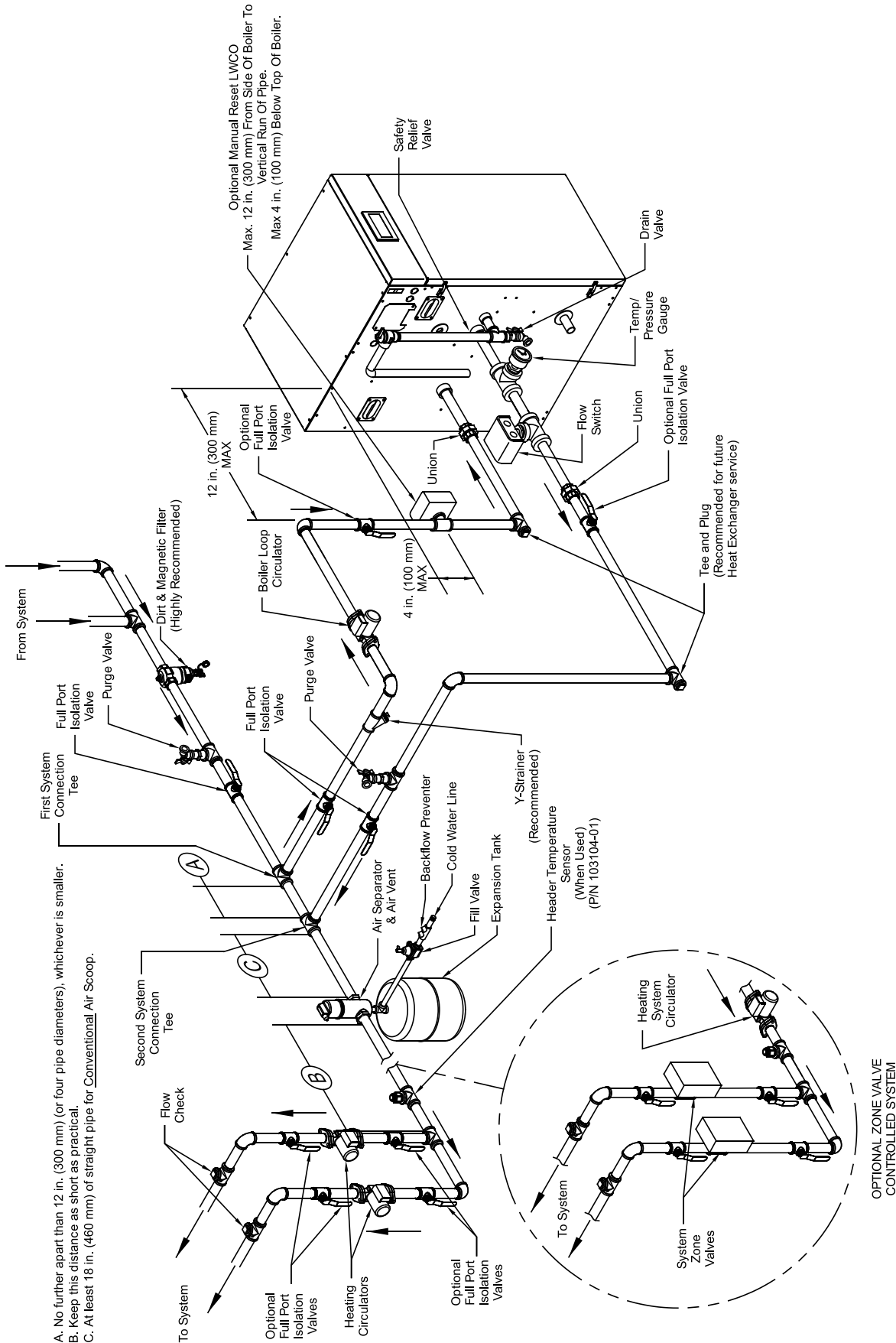

- A. No further apart than 12 in. (300 mm) (or four pipe diameters), whichever is smaller.
- B. Keep this distance as short as practical.
- C. At least 18 in. (460 mm) of straight pipe for Conventional Air Scoop.

Figure 6-9: Near Boiler Piping - Heating Only

6 Water Piping and Trim *(continued)*

D. Special Situation Piping Installation

Requirements

Observe the following guidelines when making the actual installation of the boiler piping for special situations:

1. Systems containing high level of dissolved oxygen

Many hydronic systems contain enough dissolved oxygen to cause severe corrosion damage to Alpine boiler heat exchanger. Some examples include but not limited to:

- Radiant systems employing tubing without oxygen barrier
- Systems with routine additions of fresh water
- Systems open to atmosphere

If the boiler is used in such a system, it must be separated from oxygenated water being heated with a heat exchanger as shown in Figures 6-12 and 6-13. Consult the heat exchanger manufacturer for proper heat exchanger sizing as well as flow and temperature requirements. All components on the oxygenated side of the heat exchanger,

such as the pump and expansion tank, must be designed for use in oxygenated water.

2. Piping with a Chiller - If the boiler is used in conjunction with a chiller, pipe the boiler and chiller in parallel. Use isolation valves to prevent chilled water from entering the boiler.

3. Boiler Piping with Air Handlers - Where the boiler is connected to air handlers through which refrigerated air passes, use flow control valves in the boiler piping or other automatic means to prevent gravity circulation during the cooling cycle.

Table 6-11: Multiple Boiler Water Manifold Sizing

Boiler Model	Number of Units						
	2	3	4	5	6	7	8
	Recommended Minimum Common Water Manifold Size (in.) (NPT)						
ALP399C	2½	3	3	4	5	5	5
ALP500C	3	4	4	5	5	6	6
ALP600C	3	4	5	5	6	6	6
ALP700C	4	4	5	6	6	8	8
ALP800C	4	5	5	6	6	8	8

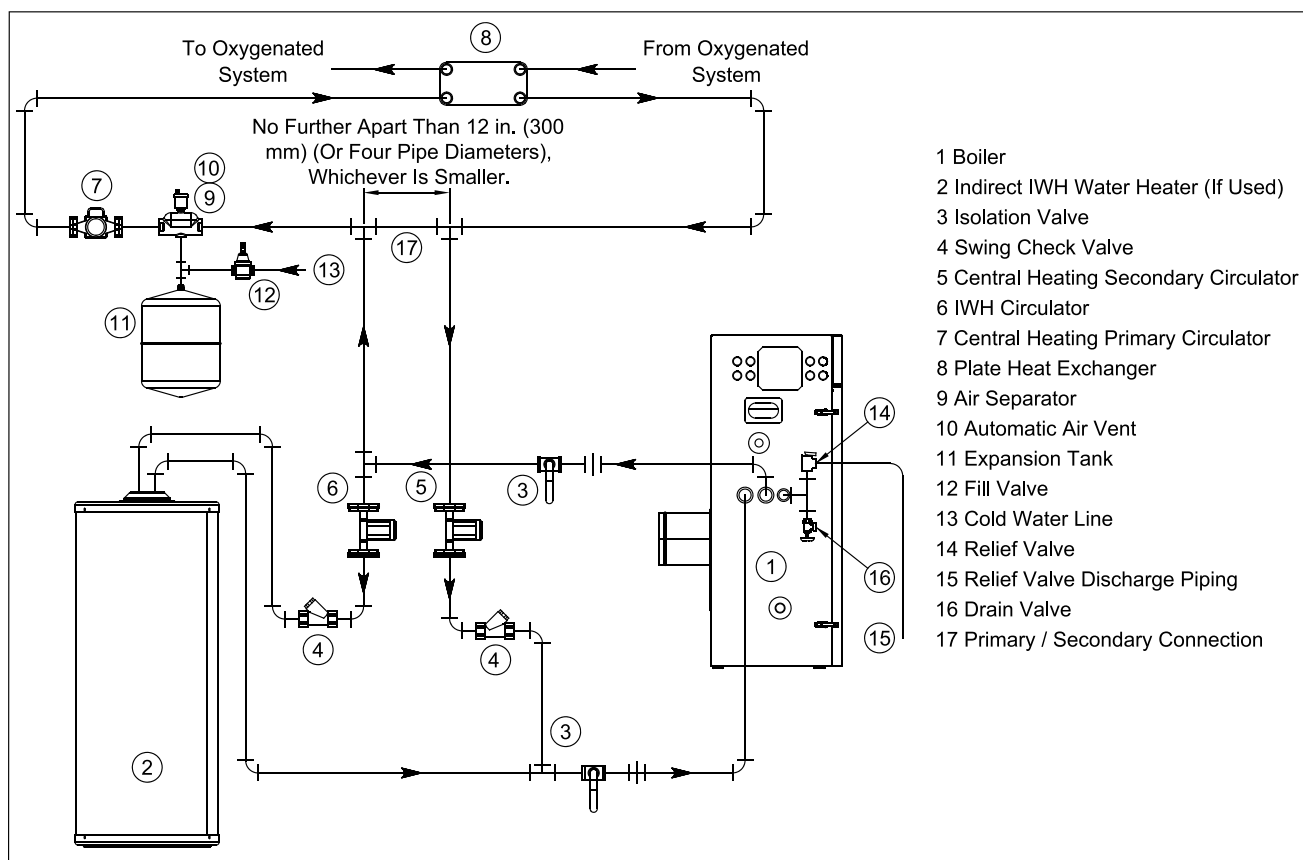
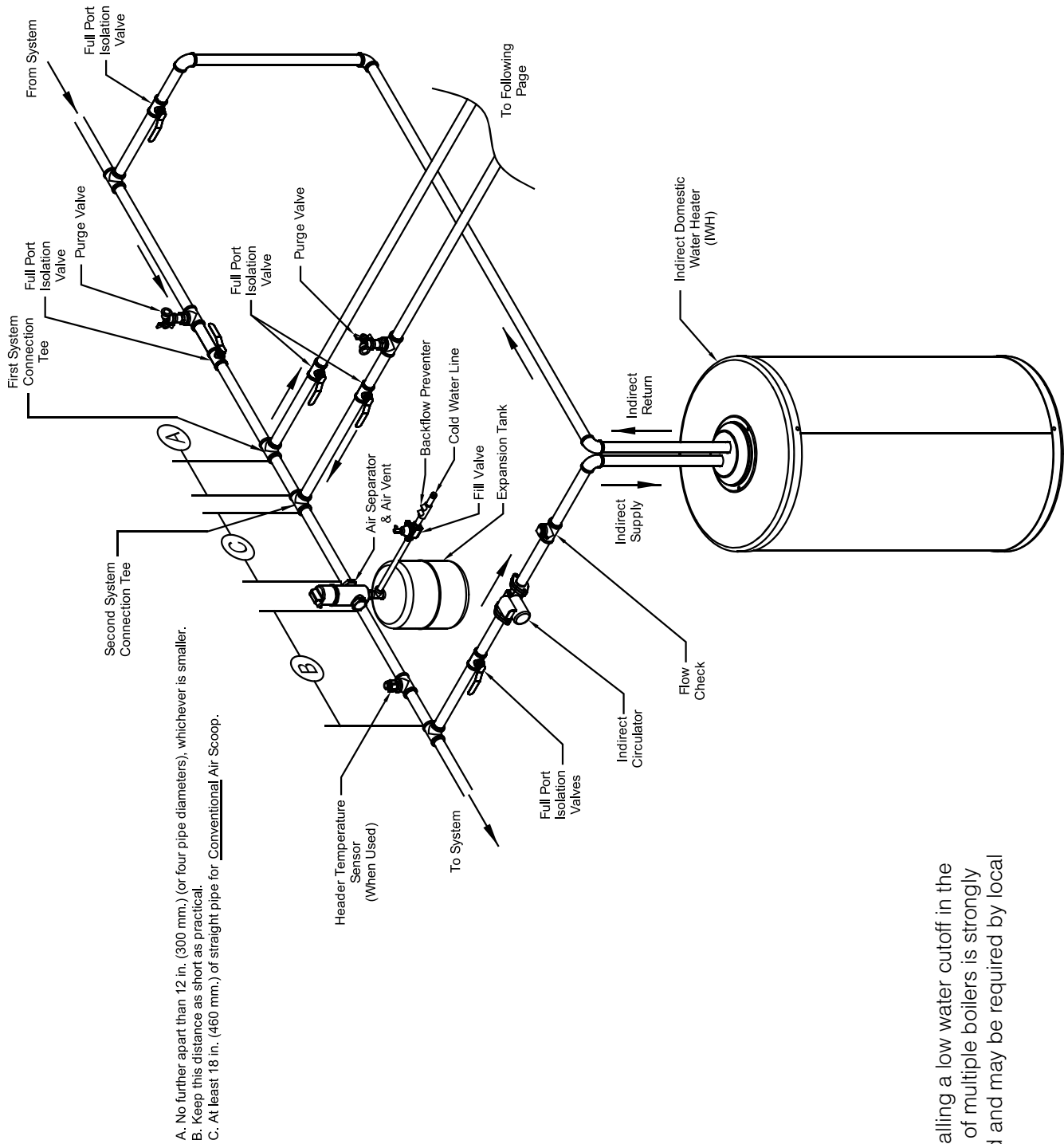

Figure 6-12: Isolation of the Boiler From Oxygenated Water with A Plate Heat Exchanger (IWH Piped as Part of Boiler Piping)

6 Water Piping and Trim *(continued)*



NOTICE: Installing a low water cutoff in the system piping of multiple boilers is strongly recommended and may be required by local codes.

Figure 6-16: Multiple Boiler Water Piping w/Domestic Hot Water Heater (Page 1 of 2)

6 Water Piping and Trim (continued)

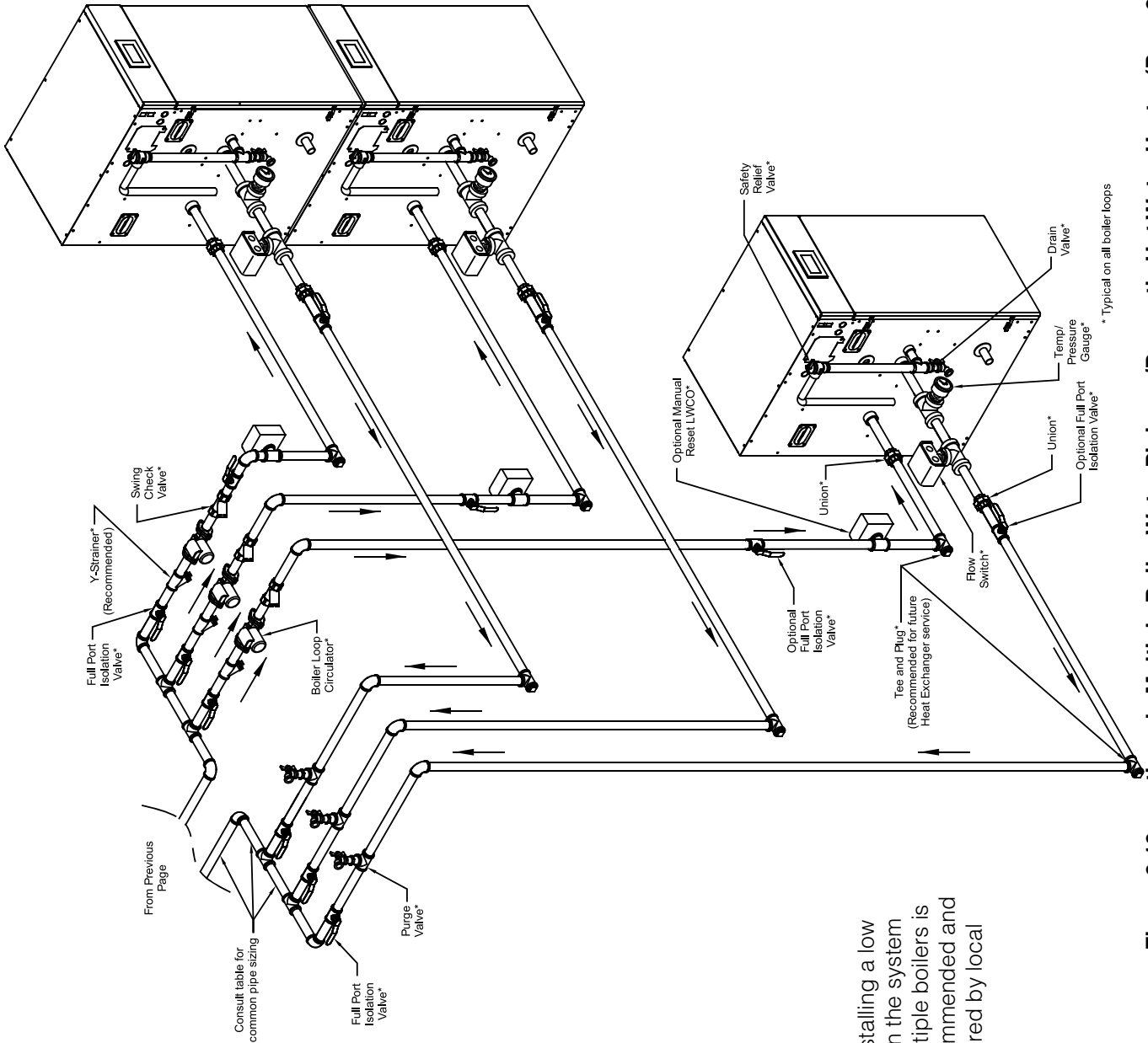

NOTICE: Installing a low water cutoff in the system piping of multiple boilers is strongly recommended and may be required by local codes.

Figure 6-16, continued: Multiple Boiler Water Piping w/Domestic Hot Water Heater (Page 2 of 2)

7 Gas Piping

WARNING

Explosion Hazard. Failure to properly pipe gas supply to boiler may result in improper operation and damage to the boiler or structure. Always assure gas piping is absolutely leak free and of the proper size and type for the connected load. An additional gas pressure regulator may be needed. Consult gas supplier.

NOTICE: Size corrugated stainless steel tubing (CSST) to ensure proper capacity and minimize flow restrictions.

A. Size gas piping. Design system to provide adequate gas supply to boiler. Consider these factors:

1. Allowable pressure drop from point of delivery to boiler. Maximum allowable system pressure is ½ psig (3.4 kPa). Actual point of delivery pressure may be less; contact gas supplier for additional information. Minimum

gas valve inlet pressure is printed on the rating label located in the boiler's vestibule compartment.

2. Maximum gas demand. Refer to the boiler's input as printed on its rating label. Also consider existing and expected future gas utilization equipment (i.e. water heater, cooking equipment).

3. Length of piping and number of fittings. Refer to Table 7-1 (natural gas) or 7-2 (LP gas) for maximum capacity of Schedule 40 pipe. Table 7-3 lists equivalent pipe length for standard fittings.

4. Specific gravity of gas. Gas piping systems for gas with a specific gravity of 0.60 can be sized directly from Table 7-1 and gas with a specific gravity of 1.5 can be sized from Table 7-2, unless authority having jurisdiction specifies a gravity factor be applied. For other specific gravity, apply gravity factor from Table 7-4. If exact specific gravity is not shown choose next higher value.

Table 7-1: Maximum Capacity of Schedule 40 Black Pipe in CFH* (Natural Gas) For Gas Pressures of 1/2 psi (3.4 kPa) or Less

Inlet Pressure 14.0 in wc (3.4 kPa) or less; 0.3 in wc (0.07 kPa) Pressure Drop											
Nominal Pipe Size, In.	Inside Diameter, In.	Length of Pipe, Ft.									
		10	20	30	40	50	60	70	80	90	100
½	0.622	131	90	72	62	55	50	46	42	40	38
¾	0.824	273	188	151	129	114	104	95	89	83	79
1	1.049	514	353	284	243	215	195	179	167	157	148
1¼	1.380	1060	726	583	499	442	400	368	343	322	304
1½	1.610	1580	1090	873	747	662	600	552	514	482	455
2	2.067	3050	2090	1680	1440	1280	1160	1060	989	928	877
2½	2.469	4860	3340	2680	2290	2030	1840	1690	1580	1480	1400
3	3.068	8580	5900	4740	4050	3590	3260	3000	2790	2610	2470

Inlet Pressure 14.0 in wc (3.4 kPa) or less; 0.5 in wc (0.12 kPa) Pressure Drop											
Nominal Pipe Size, In.	Inside Diameter, In.	Length of Pipe, Ft.									
		10	20	30	40	50	60	70	80	90	100
½	0.622	172	118	95	81	72	65	60	56	52	50
¾	0.824	360	247	199	170	151	137	126	117	110	104
1	1.049	678	466	374	320	284	257	237	220	207	195
1¼	1.380	1390	957	768	657	583	528	486	452	424	400
1½	1.610	2090	1430	1150	985	873	791	728	677	635	600
2	2.067	4020	2760	2220	1900	1680	1520	1400	1300	1220	1160
2½	2.469	6400	4400	3530	3020	2680	2430	2230	2080	1950	1840
3	3.068	11300	7780	6250	5350	4740	4290	3950	3674	3450	3260

* 1 CFH of Natural Gas is approximately equal to 1 MBH; contact your gas supplier for the actual heating value of your gas.

7 Gas Piping *(continued)*

For materials or conditions other than those listed above, refer to *National Fuel Gas Code*, ANSI Z223.1/NFPA 54 or *Natural Gas and Propane Installation Code*, CAN/CSA B149.1, or size system using standard engineering methods acceptable to authority having jurisdiction.

Table 7-4: Specific Gravity Correction Factors

Specific Gravity	Correction Factor	Specific Gravity	Correction Factor
0.60	1.00	0.90	0.82
0.65	0.96	1.00	0.78
0.70	0.93	1.10	0.74
0.75	0.90	1.20	0.71
0.80	0.87	1.30	0.68
0.85	0.81	1.40	0.66

Table 7-2: Maximum Capacity of Schedule 40 Black Pipe in CFH* (LP Gas) For Gas Pressures of 1/2 psi (3.4 kPa) or Less

Inlet Pressure 11.0 in wc (2.7 kPa); 0.3 in wc (0.07 kPa) Pressure Drop											
Nominal Pipe Size, In.	Inside Diameter, In.	Length of Pipe, Ft.									
		10	20	30	40	50	60	70	80	90	100
½	0.622	88	60	48	41	37	33	31	29	27	25
¾	0.824	184	126	101	87	77	70	64	60	56	53
1	1.049	346	238	191	163	145	131	121	112	105	100
1¼	1.380	710	488	392	336	297	269	248	231	216	204
1½	1.610	1064	732	588	503	446	404	371	346	324	306
2	2.067	2050	1409	1131	968	858	778	715	666	624	590
2½	2.469	3267	2246	1803	1543	1368	1239	1140	1061	995	940
3	3.068	5776	3970	3188	2729	2418	2191	2016	1875	1760	1662

Inlet Pressure 11.0 in wc (2.7 kPa); 0.5 in wc (0.12 kPa) Pressure Drop											
Nominal Pipe Size, In.	Inside Diameter, In.	Length of Pipe, Ft.									
		10	20	30	40	50	60	70	80	90	100
½	0.622	116	80	64	55	48	44	40	38	35	33
¾	0.824	242	166	134	114	101	92	85	79	74	70
1	1.049	456	314	252	215	191	173	159	148	139	131
1¼	1.380	937	644	517	442	392	355	327	304	285	269
1½	1.610	1403	964	775	663	588	532	490	456	427	404
2	2.067	2703	1858	1492	1277	1131	1025	943	877	823	778
2½	2.469	4308	2961	2377	2035	1803	1634	1503	1399	1312	1239
3	3.068	7615	5234	4203	3597	3188	2889	2658	2472	2320	2191

* 1 CFH of LP Gas is approximately equal to 2.5 MBH; contact your gas supplier for the actual heating value of your gas.

Table 7-3: Equivalent Lengths of Standard Pipe Fittings & Valves (ft)

Nominal Pipe Size, Inc.	Inside Diameter, In.	Valves (Screwed) - Fully Open				Screwed Fittings				
		Gate	Globe	Angle	Swing Check	45° Elbow	90° Elbow	180 Close Return Bend	90 Tee Flow Through Run	90 Tee, Flow Through Branch
½	0.622	0.4	17.3	8.7	4.3	0.7	1.6	3.5	1.6	3.1
¾	0.824	0.5	22.9	11.4	5.7	1.0	2.1	4.6	2.1	4.1
1	1.049	0.6	29.1	14.6	7.3	1.2	2.6	5.8	2.6	5.2
1¼	1.38	0.8	38.3	19.1	9.6	1.6	3.5	7.7	3.5	6.9
1½	1.61	0.9	44.7	22.4	11.2	1.9	4.0	9.0	4.0	8.0
2	2.067	1.2	57.4	28.7	14.4	2.4	5.2	11.5	5.2	10.3
2½	2.469	1.4	68.5	34.3	17.1	2.9	6.2	13.7	6.2	12.3
3	3.068	1.8	85.2	42.6	21.3	3.6	7.7	17.1	7.7	15.3

7 Gas Piping *(continued)*

⚠ WARNING

- **Explosion Hazard.** Failure to use proper thread compounds on all gas connectors may result in leaks of flammable gas.
- Gas supply to boiler and system must be absolutely shut off prior to installing or servicing boiler gas piping.

B. Connect boiler gas valve to gas supply system.

- 1. Use methods and materials in accordance** with local plumbing codes and requirements of gas supplier. In absence of such requirements, follow *National Fuel Gas Code*, ANSI Z223.1/ NFPA 54 and/or *Natural Gas and Propane Installation Code*, CAN/CSA B149.1.
- 2. Use thread (joint) compounds (pipe dope)** resistant to action of liquefied petroleum gas.
- 3. Alpine boilers have factory supplied** miscellaneous parts cartons, which include gas-piping components to connect boiler gas valve(s) to gas supply system. Install these components prior to connecting boiler to gas supply system piping as follows:

Boiler Model	Miscellaneous Parts Carton
ALP399C	106315-01
ALP500C	106316-01
ALP600C	106317-01
ALP700C	
ALP800C	

Models ALP399C and ALP500C

- Locate and remove the $\frac{3}{4}$ in. NPT x 6 in. long black nipple and $\frac{3}{4}$ in. NPT external gas shutoff valve (required).
- Insert nipple through grommet in left side panel. Apply pipe dope and thread nipple into gas valve (ALP399C) or gas inlet tee (ALP500C).
- Mount the $\frac{3}{4}$ in. NPT external gas shutoff valve onto the nipple threaded end outside of the jacket left side panel.
- Install sediment trap, ground-joint union and manual shut-off valve upstream of mounted factory supplied manual shut-off valve. See Figure 7-5 "Recommended Gas Piping".

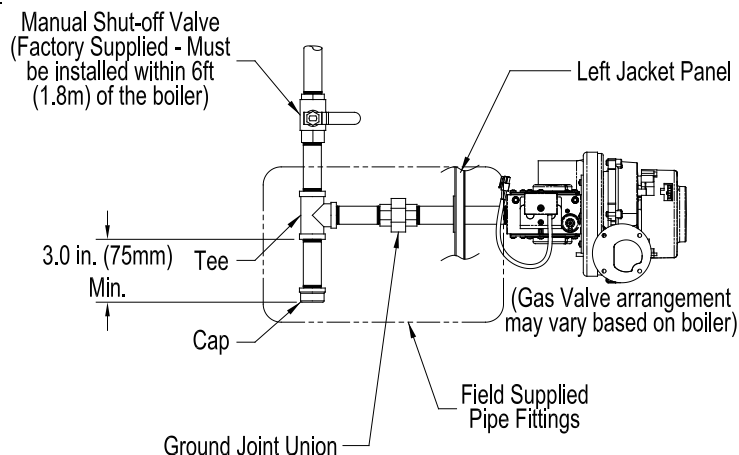

Figure 7-5: Recommended Gas Piping

Models ALP600C, ALP700C and ALP800C

- Locate and remove 1 in. NPT external gas shutoff valve (required).
 - Insert nipple through grommet in left side panel. Apply pipe dope and thread nipple into gas inlet tee or cross.
 - Mount the 1 in. NPT external gas shutoff valve onto the nipple threaded end outside of the jacket left side panel.
 - Install sediment trap, ground-joint union and manual shut-off valve upstream of mounted factory supplied manual shut-off valve. See Figure 7-5 "Recommended Gas Piping".
- 4. All above ground gas piping** upstream from manual shut-off valve must be electrically continuous and bonded to a grounding electrode. Do not use gas piping as grounding electrode. Refer to *National Electrical Code*, NFPA 70 and/or *Canadian Electrical Code Part 1*, CSA C22.1, Electrical Code.

Table 7-6: Min./Max. Inlet Gas Pressure Ratings

Boiler Model	Natural/LP Gas Max, in. wc (kPa)	Natural Gas Min, in. wc (kPa)	LP Gas Min, in. wc (kPa)
ALP399C	14.0 (3.49)	4.0 (1.00)	8.0 (1.99)
ALP500C			
ALP600C			
ALP700C			
ALP800C			

7 Gas Piping *(continued)*

- C. Pressure test.** See Table 7-6 for Alpine Min./ Max. Pressure Ratings. The boiler and its gas connection must be leak tested before placing boiler in operation.
- 1. Protect boiler gas control valve.** For all testing over ½ psig (3.4 kPa), boiler and its individual shutoff valve must be disconnected from gas supply piping. For testing at ½ psig (3.4 kPa) or less, isolate boiler from gas supply piping by closing boiler's individual manual shutoff valve.
 - 2. Locate leaks** using approved combustible gas non-corrosive leak detector solution.

DANGER

Explosion Hazard. Do not use matches, candles, open flames or other ignition source to check for leaks.

- D. Alpine Models ALP500C, ALP600C, ALP700C, ALP800C** (if equipped with optional low and high gas pressure switches)

- 1. Verify low and high gas pressure switch settings** are within the range shown in kit instructions. The switches are preset for natural gas. For LP gas, the low gas pressure switch setting must be adjusted.
- 2. The low gas pressure switch** must be reset after the boiler is piped to the gas supply and before it is fired.
- 3. For the low and high gas pressure switches** proper operation, the boiler inlet gas pressure must be within the range shown in Table 7-6.
- 4. The gas pressure can be measured** at the gas valve inlet pressure port. Refer to Figure 7-7 "Gas Inlet Pressure Tap and Pressure Switch Location".
- 5. If either pressure switch is tripped,** it must be manually reset before the boiler can be restarted.

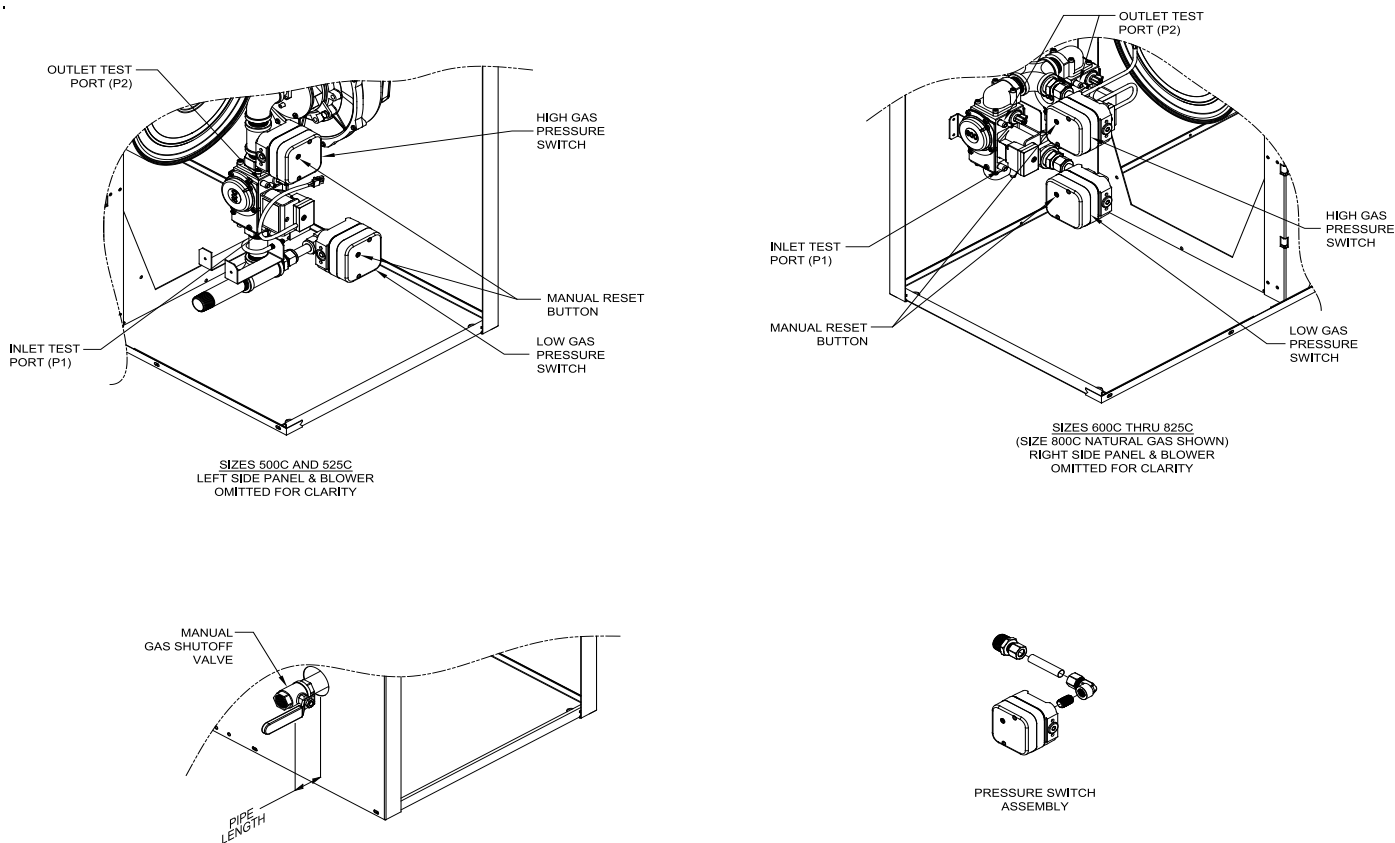

Figure 7-7: Gas Inlet Pressure Tap and Pressure Switch Location

7 Gas Piping *(continued)*

E. Gas Piping for Multiple Boiler Installation

1. **Individual module (boiler) gas pipe sizing specific details** - see Paragraph A.
2. **Individual module (boiler) recommended gas piping detail** - see Figure 7-5.
3. **An additional gas pressure regulator(s)** may need to be installed to properly regulate inlet gas pressure at the smallest individual module (boiler).

CAUTION

If gas pressure in the building is above ½ psig (3.4 kPa), an additional gas pressure regulator is required. Using one additional regulator for multiple boilers may result in unsafe boiler operation. The additional regulator must be able to properly regulate gas pressure at the input of the smallest boiler. If the regulator cannot do this, two or more additional regulators are required. Consult regulator manufacturer and/or local gas supplier for instructions and equipment ratings.

8 Electrical

DANGER

Electrical Shock Hazard. Positively assure all electrical connections are unpowered before attempting installation or service of electrical components or connections of the boiler or building. Lock out all electrical boxes with padlock once power is turned off.

WARNING

Electrical Shock Hazard. Failure to properly wire electrical connections to the boiler may result in serious physical harm.

- Electrical power may be from more than one source. Make sure all power is off before attempting any electrical work.
- Each boiler must be protected with a properly sized over-current device.
- Never jump out or make inoperative any safety or operating controls.
- The wiring diagrams contained in this manual are for reference purposes only. Each boiler is shipped with a wiring diagram attached to the front door. Refer to this diagram and the wiring diagram of any controls used with the boiler. Read, understand and follow all wiring instructions supplied with the controls.

NOTICE: All wire, wire nuts, controls etc. are installer supplied unless otherwise noted.

A. General. Install wiring and electrically ground boiler in accordance with authority having jurisdiction or, in the absence of such requirements, follow the *National Electrical Code*, *NFPA 70*, and/or *Canadian Electrical Code Part 1*, *CSA C22.1 Electrical Code*. Provide over current protection not greater than 15A.

B. A separate electrical circuit must be run from the main electrical service with an over-current device/disconnect in the circuit. A service switch is recommended and may be required by some local jurisdictions. Install the service switch in the line voltage “Hot” leg of the power supply. Locate the service switch such that the boiler can be shut-off without exposing personnel to danger in the event of an emergency.

C. Power Requirements

Nominal boiler current draw is provided in Table 8-1. These values are for planning purposes only and represent only the boiler’s power consumption. To obtain total system power consumption add any selected circulator and component current draws.

Table 8-1: Boiler Current Draw

Model Number	Nominal Current (amps)
ALP399C	< 7
ALP500C	< 6
ALP600C	< 8
ALP700C	< 8
ALP800C	< 8

D. Boiler wiring. Refer to Figures 8-5 and 8-6.

- 1. Connect to field wiring** inside the junction box, located on the upper left side of the boiler as shown in Figure 8-2. Inside the junction box are two printed circuit boards (PCB’s), 120 VAC Connections on the left and Low Voltage Connections on the right.
- 2. 120 VAC connections** (line voltage) are located on left PCB and are shown in Figure 8-3. Do not exceed 5.6A total pump current draw (system + DHW + boiler pumps). One 6.3A slow-blow pump fuse and spare are provided.

8 Electrical *(continued)*

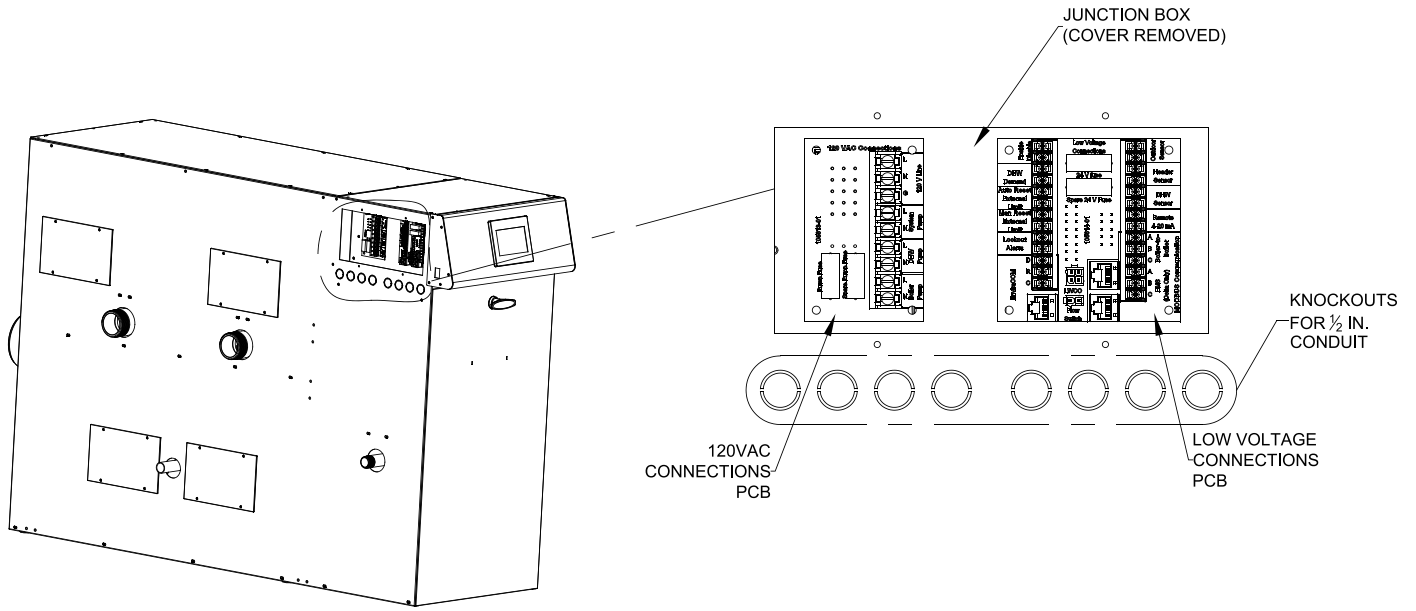

Figure 8-2: PCB Locations for Field Wiring

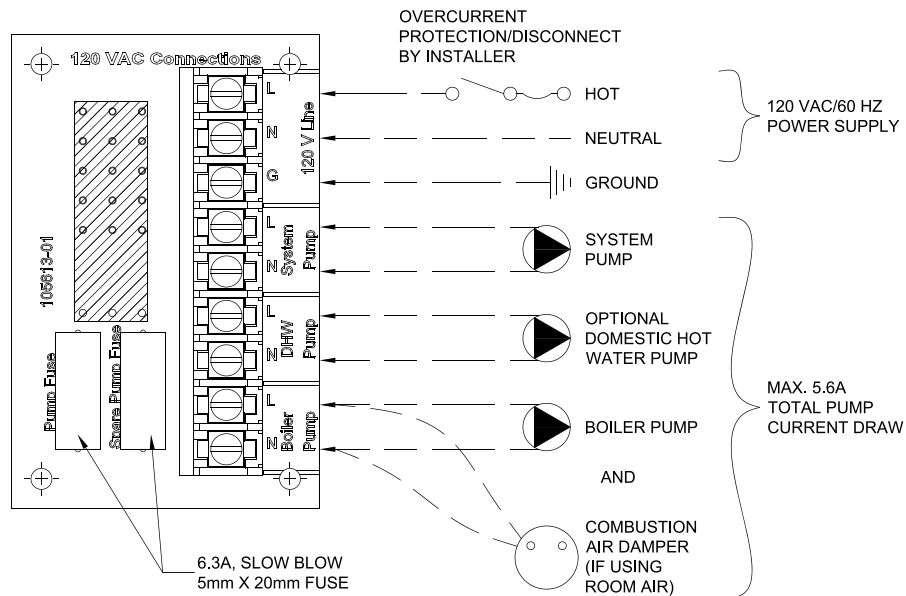

Figure 8-3: 120 VAC Field Wiring

8 Electrical *(continued)*

3. **24 VAC low voltage connections** are located on left side of right PCB and are shown in Figure 8-4. One 24V fuse and spare are provided. ALP399C and ALP500C use 1.6A slow-blow fuse. ALP600C, ALP700C and ALP800C use 2.0A fast-acting fuse.
4. **5VDC low voltage connections** are located on right side of right PCB and are shown in Figure 8-4.
5. **If the outdoor sensor is connected**, the boiler will adjust the target space heating set point supply water temperature downwards as the outdoor air temperature increases. If used, this sensor should be located on the outside of the structure in an area where it will sense the average air temperature around the house. Avoid placing this sensor in areas where it may be covered with ice or snow. Locations where the sensor will pick up direct radiation from the sun should also be avoided. Avoid placing the sensor near potential sources of electrical noise such as transformers, power lines, and fluorescent lighting. Wire the sensor to the boiler using 22 gauge or larger wire. As with the sensor, the sensor wiring should be routed away from sources of electrical noise. Where it is impossible to avoid such noise sources, wire the sensor using a 2 conductor, UL Type CM, AWM Style 2092, 300 Volt 60°C shielded cable. Connect one end of the shielding on this cable to ground.

NOTICE: When making low voltage connections, make sure that no external power source is present in the thermostat or limit circuits. If such a power source is present, it could destroy the boiler's microprocessor control. One example of an external power source that could be inadvertently connected to the low voltage connections is a transformer in old thermostat wiring.

E. Flow Switch Wiring

Alpine boilers require a flow switch to prevent boiler overheating. See Section 6, "Water Piping and Trim", and flow switch instruction sheet for piping details. The flow switch and flow switch wire harness are factory provided.

1. **Wire flow switch harness to boiler.** Connect Molex on harness to boiler low voltage connector P11, labeled "Flow Switch".
2. **Wire flow switch harness to flow switch.** Connect fork terminals on harness to flow switch NO (normally open) and COM (common) terminal screws.

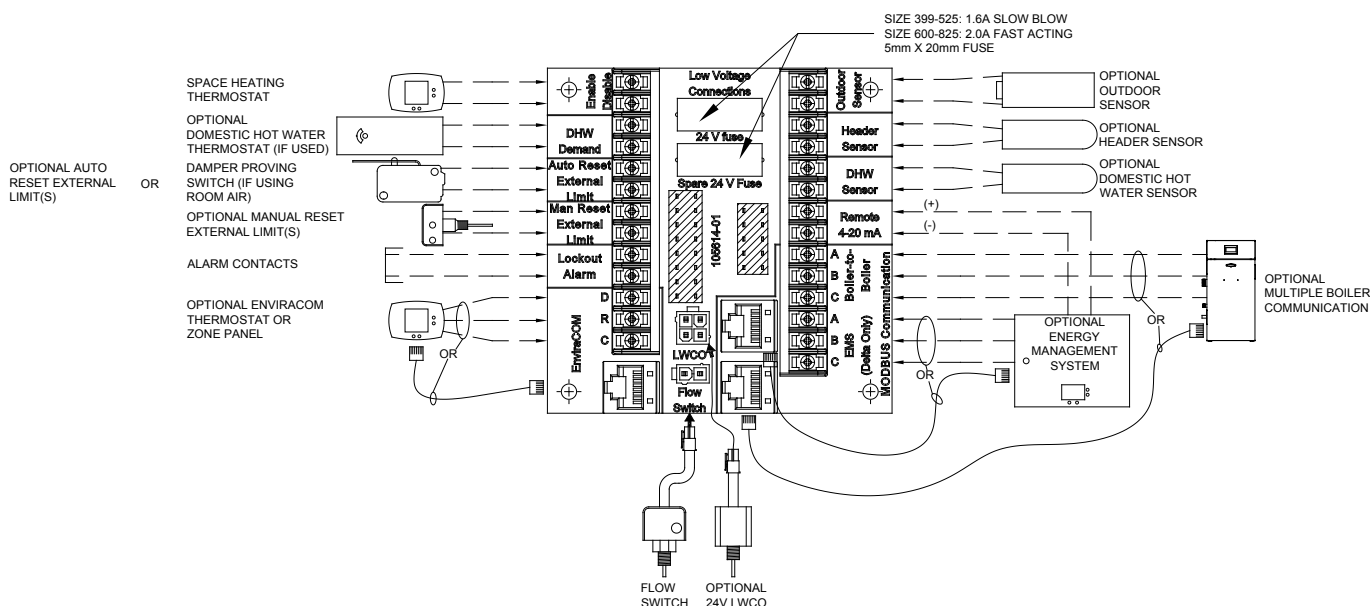

Figure 8-4: Low Voltage Field Wiring

8 Electrical (continued)

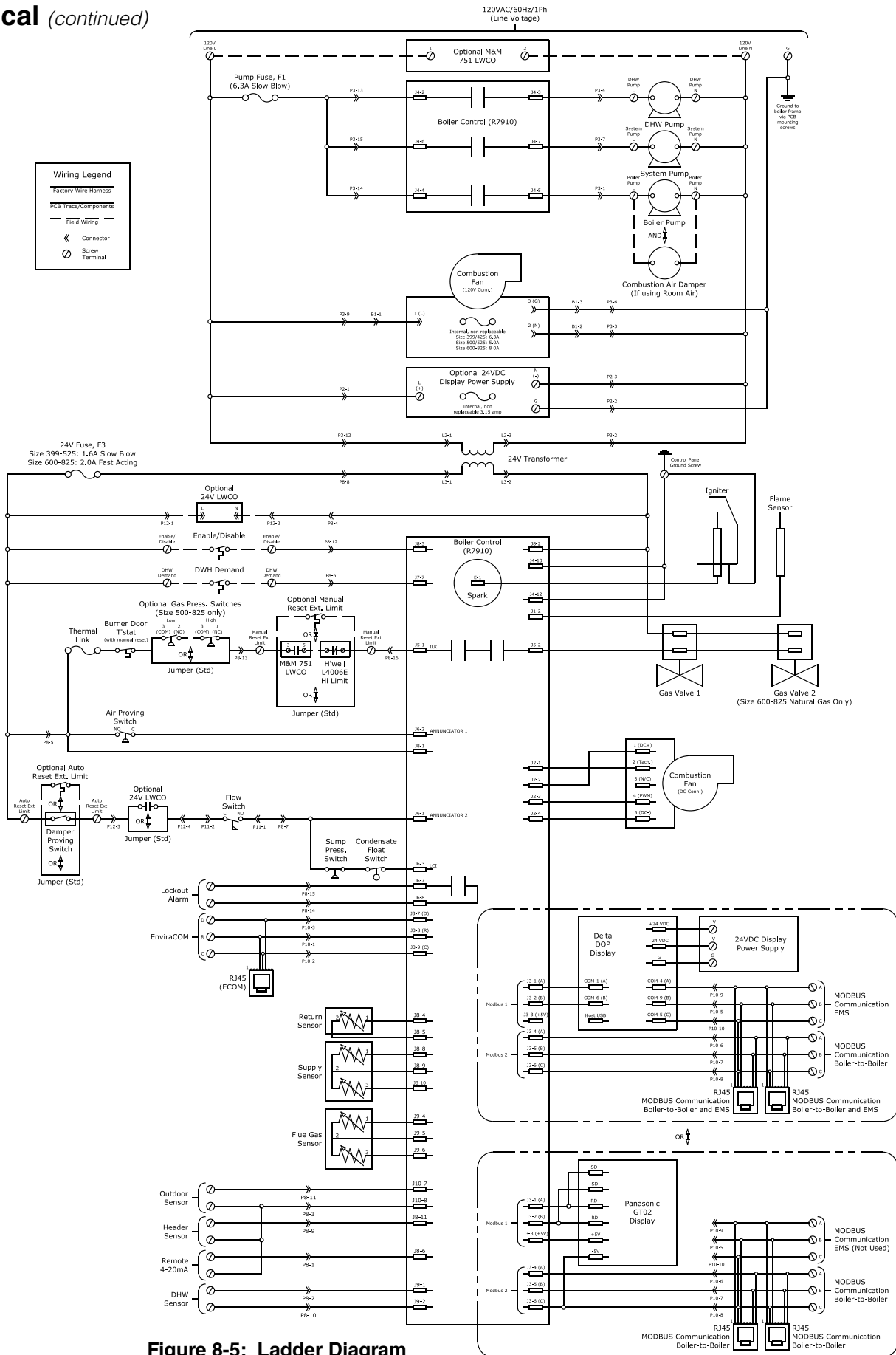

Figure 8-5: Ladder Diagram

8 Electrical (continued)

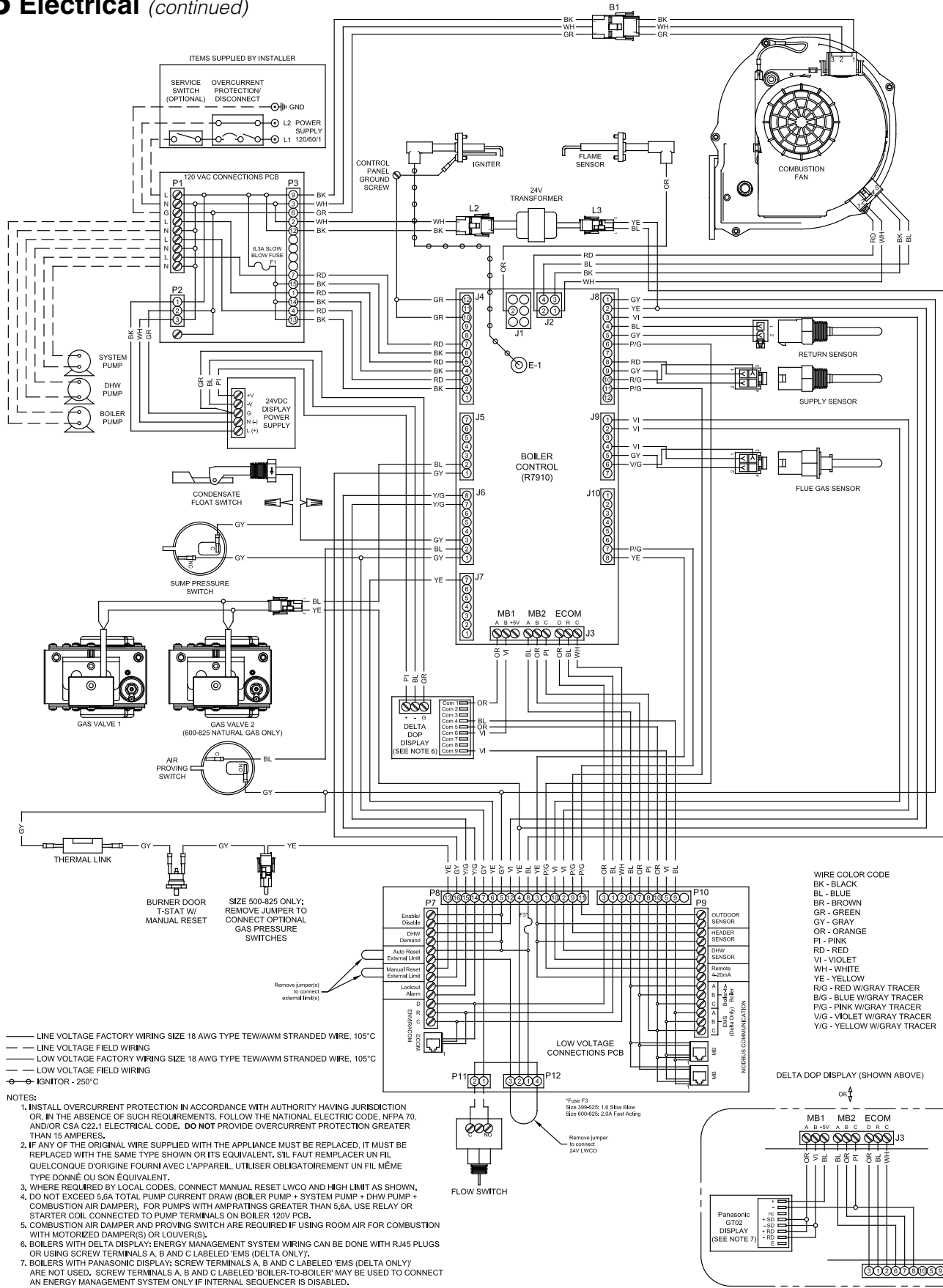
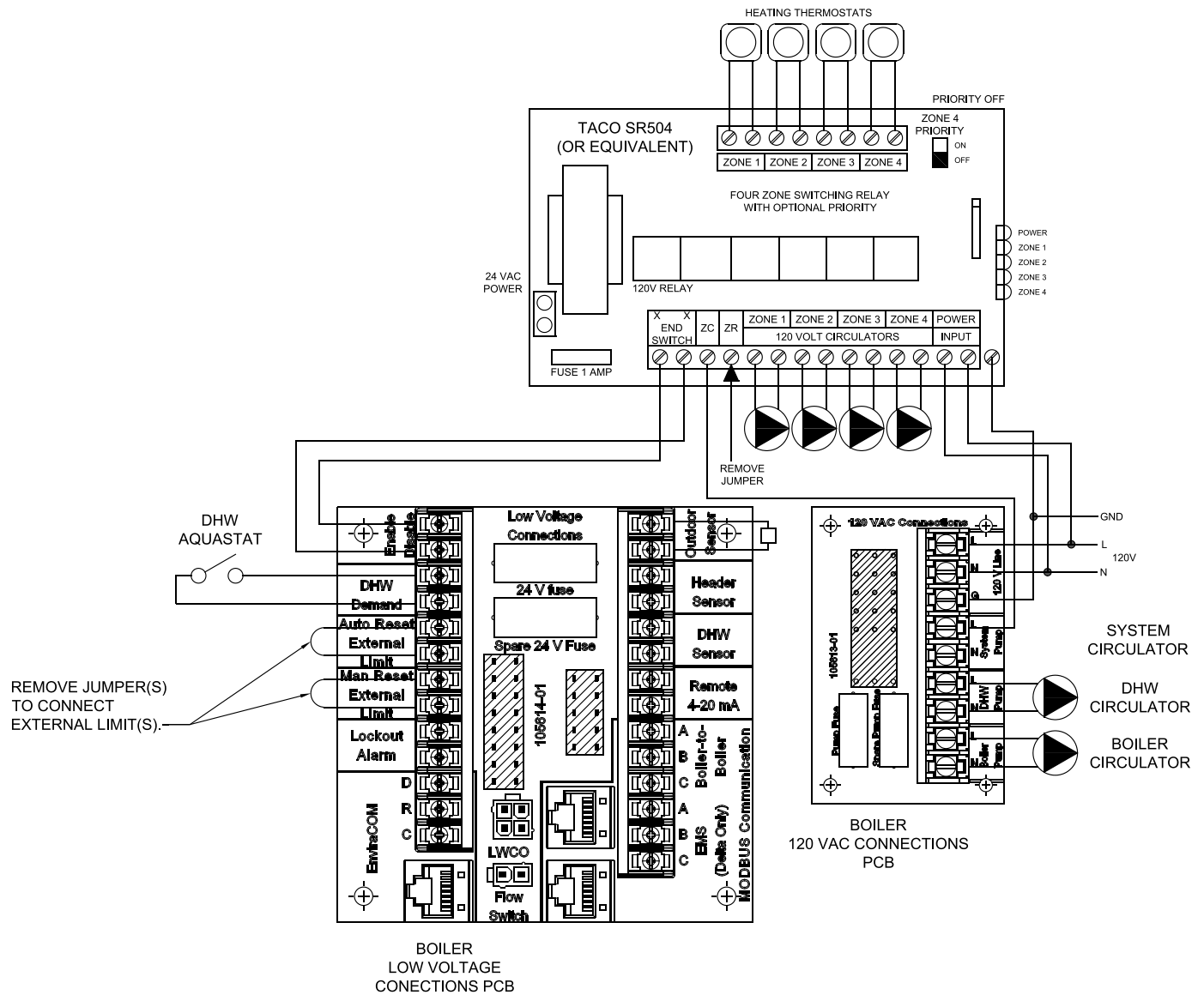

Figure 8-6: Wiring Connections Diagram

8 Electrical *(continued)*



***USE SAME POWER SOURCE FOR ALL CONTROLS AND
ENSURE POLARITY TO ALL CONTROL DEVICES IS CORRECT

Figure 8-7: Modified Wiring For DHW Priority When Using Low Flow Circulator Piped Off System Header - Heating (with Central Heating Circulators) Plus Alternately Piped Indirect Water Heater

8 Electrical (continued)

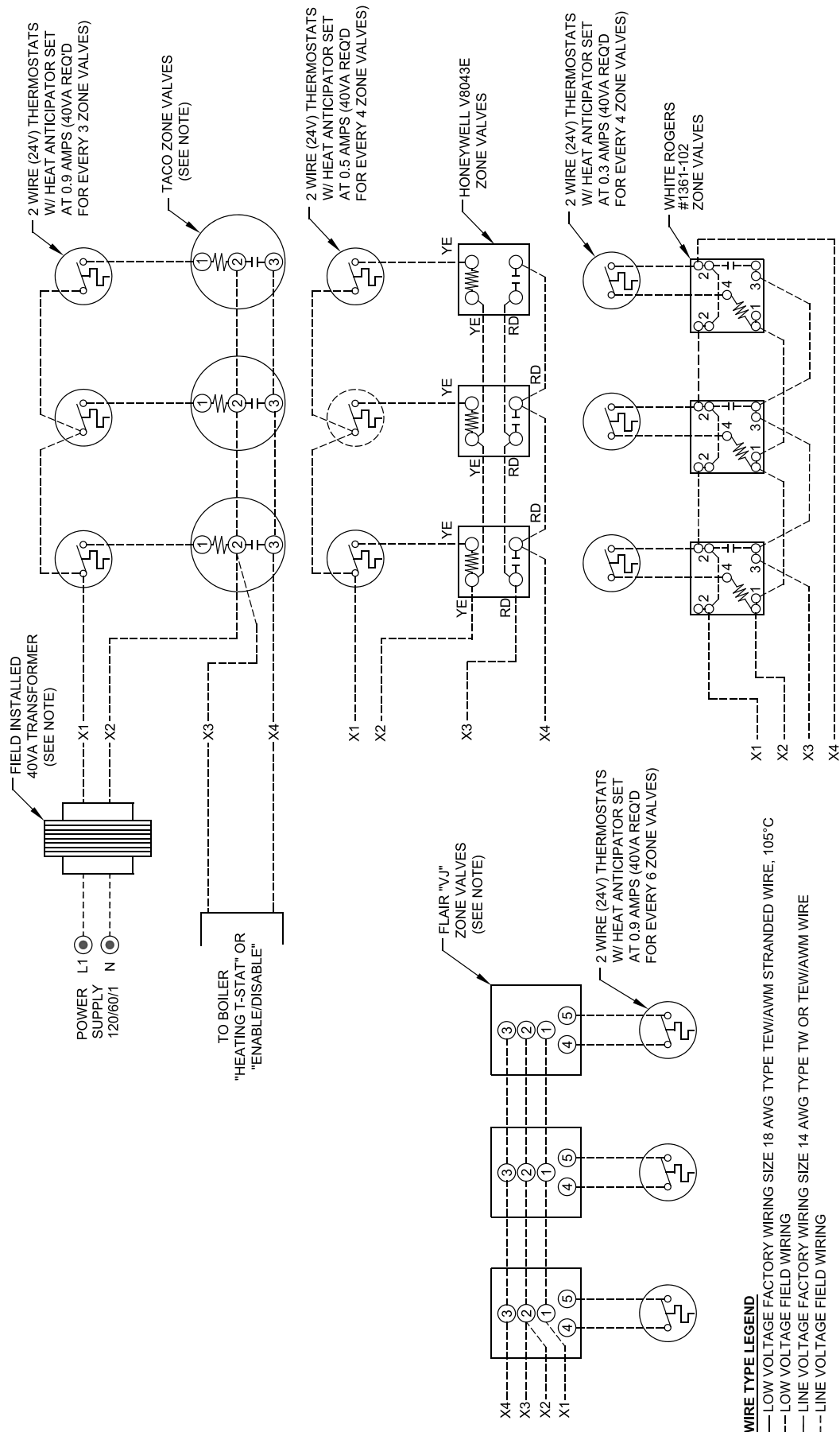

NOTE: CHECK FOR CROSS-PHASING BETWEEN BOILER TRANSFORMER AND FIELD SUPPLIED TRANSFORMER ON TACO AND FLAIR ZONE VALVE CIRCUITS. IF CROSS-PHASING OCCURS, CORRECT BY SWITCHING X1 AND X2 OR X3 AND X4. ALSO, BOILER SECONDARY SIDE (24V) IS GROUNDED ON EI AND CANADIAN MODELS AND THE ZONE CIRCUIT MAY NOT OPERATE IF A SEPARATE GROUND IS MADE IN THE ZONE CIRCUIT.

Figure 8-8: Modified Wiring For DHW Priority When Using Low Flow Circulator Piped Off System Header - Heating (with Central Heating Zone Valves) Plus Alternately Piped Indirect Water Heater

8 Electrical (continued)

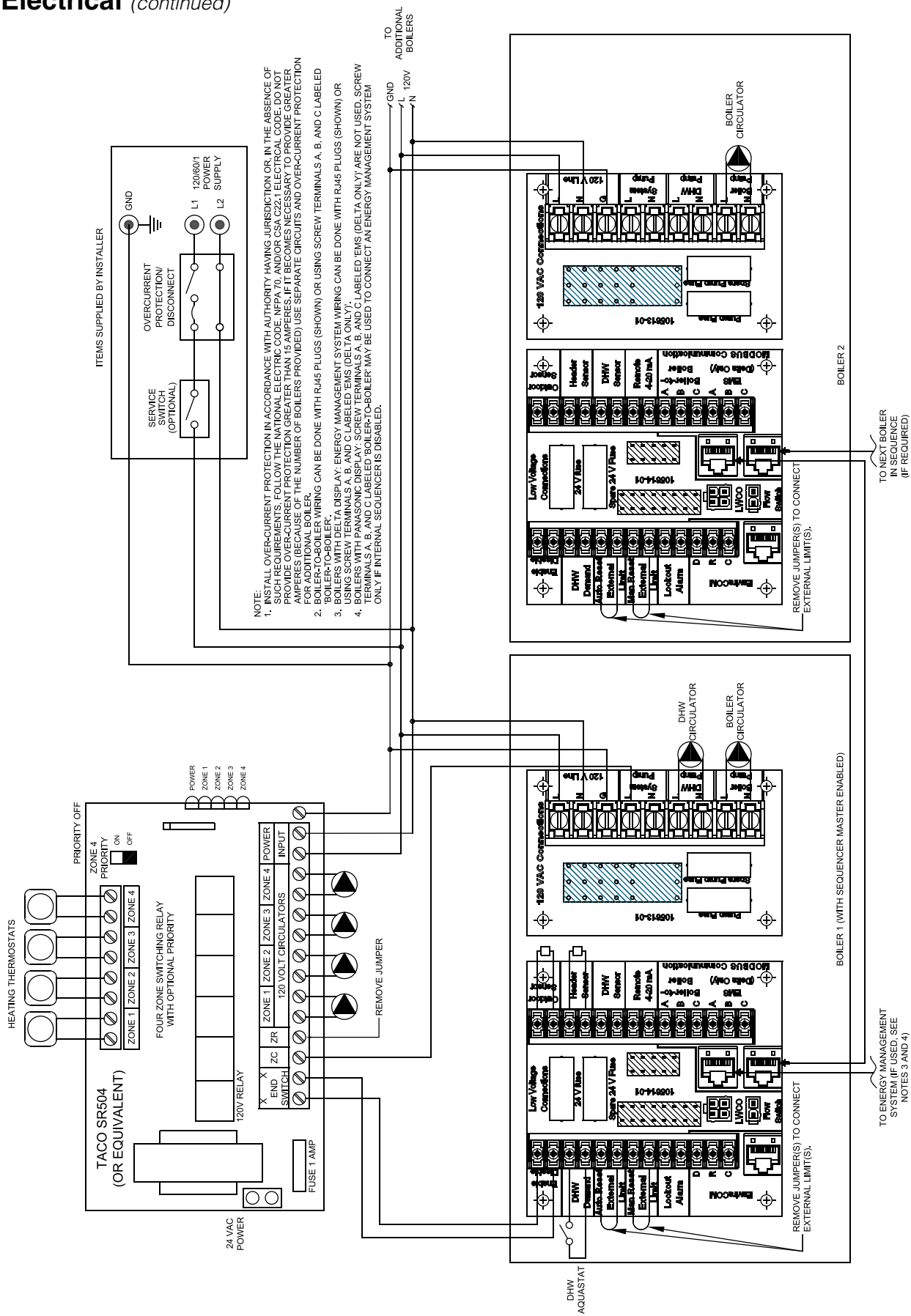

NOTE:

1. INSTALL OVER-CURRENT PROTECTION IN ACCORDANCE WITH AUTHORITY HAVING JURISDICTION OR, IN THE ABSENCE OF SUCH REQUIREMENTS, FOLLOW THE NATIONAL ELECTRIC CODE, NFPA 70, AND/OR CSA C22.1 ELECTRICAL CODE. DO NOT PROVIDE OVER-CURRENT PROTECTION GREATER THAN 15 AMPERES. IF IT BECOMES NECESSARY TO PROVIDE GREATER PROTECTION, THE NUMBER OF BOILERS PROVIDED USE SEPARATE CIRCUITS AND OVERCURRENT PROTECTION FOR ADDITIONAL BOILER.
2. BOILER-TO-BOILER WIRING CAN BE DONE WITH R45 PLUGS (SHOWN) OR USING SCREW TERMINALS A, B, AND C. LABELED 'BOILER-TO-BOILER'.
3. BOILERS WITH DELTA DISPLAY: ENERGY MANAGEMENT SYSTEM WIRING CAN BE DONE WITH R45 PLUGS (SHOWN) OR USING SCREW TERMINALS A, B, AND C LABELED 'EMS (DELTA ONLY)'.
4. BOILERS WITH PANASONIC DISPLAY: SCREW TERMINALS A, B, AND C LABELED 'EMS (DELTA ONLY)' ARE NOT USED. SCREW TERMINALS A, B, AND C LABELED 'BOILER' MAY BE USED TO CONNECT AN ENERGY MANAGEMENT SYSTEM ONLY IF INTERNAL SEQUENCER IS DISABLED.

Figure 8-9: Multiple Boiler Wiring Diagram
Internal Multiple Boiler Control Sequencer
(Two Boilers Shown, Typical Connections for up to Eight Boilers)

8 Electrical (continued)

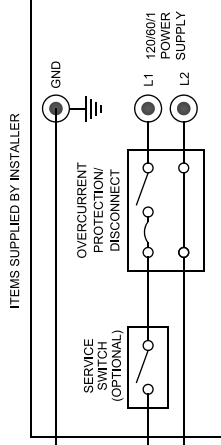

- NOTE:
1. INSTALL OVERCURRENT PROTECTION IN ACCORDANCE WITH AUTHORITY HAVING JURISDICTION OR, IN THE ABSENCE OF SUCH REQUIREMENTS, FOLLOW THE NATIONAL ELECTRIC CODE, NFPA 70, AND/OR CSA C22.1 ELECTRICAL CODE. DO NOT PROVIDE OVERCURRENT PROTECTION GREATER THAN 15 AMPERES. IF IT BECOMES NECESSARY TO PROVIDE GREATER PROTECTION, BECAUSE OF THE NUMBER OF BOILERS PROVIDED, USE SEPARATE CIRCUITS AND OVERCURRENT PROTECTION FOR EACH BOILER.
 2. BOILER-TO-BOILER WIRING CAN BE DONE WITH RJ45 PLUGS (SHOWN) OR USING SCREW TERMINALS A, B, AND C LABELED BOILER-TO-BOILER.
 3. BOILERS WITH DELTA DISPLAY: ENERGY MANAGEMENT SYSTEM WIRING CAN BE DONE WITH RJ45 PLUGS (SHOWN) OR USING SCREW TERMINALS A, B, AND C LABELED EMS (DELTA ONLY).
 4. BOILERS WITH PANASONIC DISPLAY: SCREW TERMINALS A, B, AND C LABELED BOILER-TO-BOILER MAY BE USED TO CONNECT AN ENERGY MANAGEMENT SYSTEM ONLY IF INTERNAL SEQUENCER IS DISABLED.

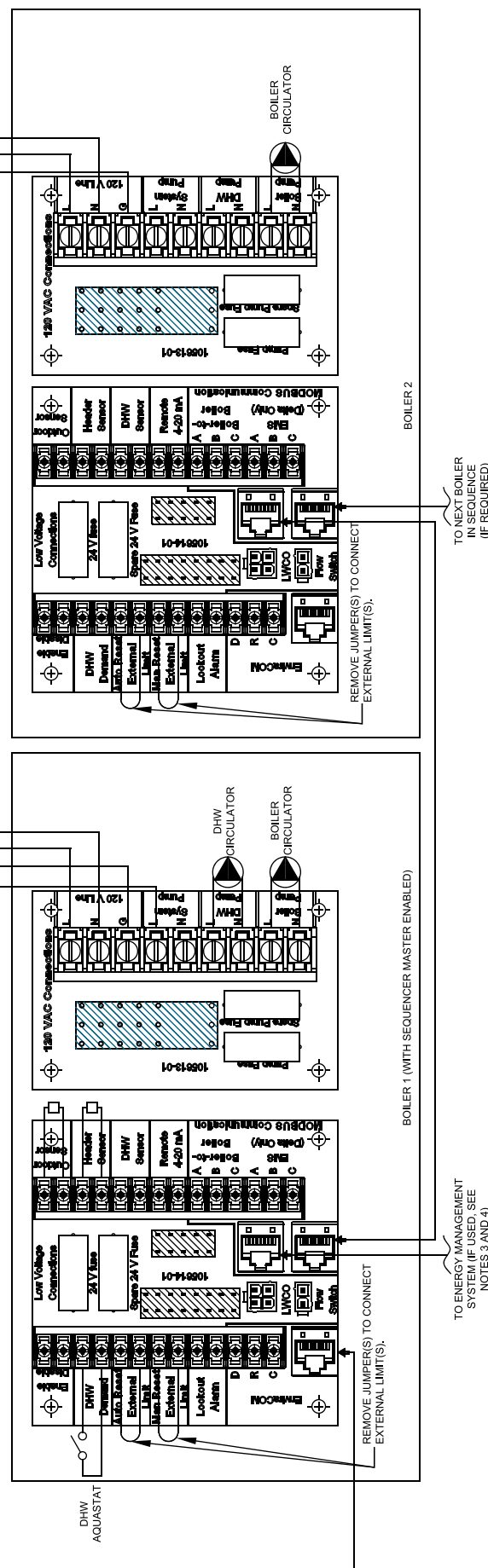
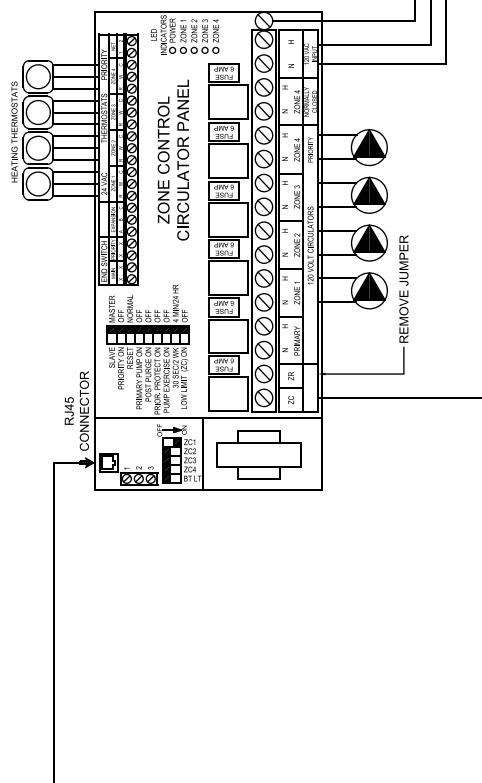

Figure 8-10: Boiler-to-Boiler Communication (with Zone Control Circulator Panel)

8 Electrical (continued)

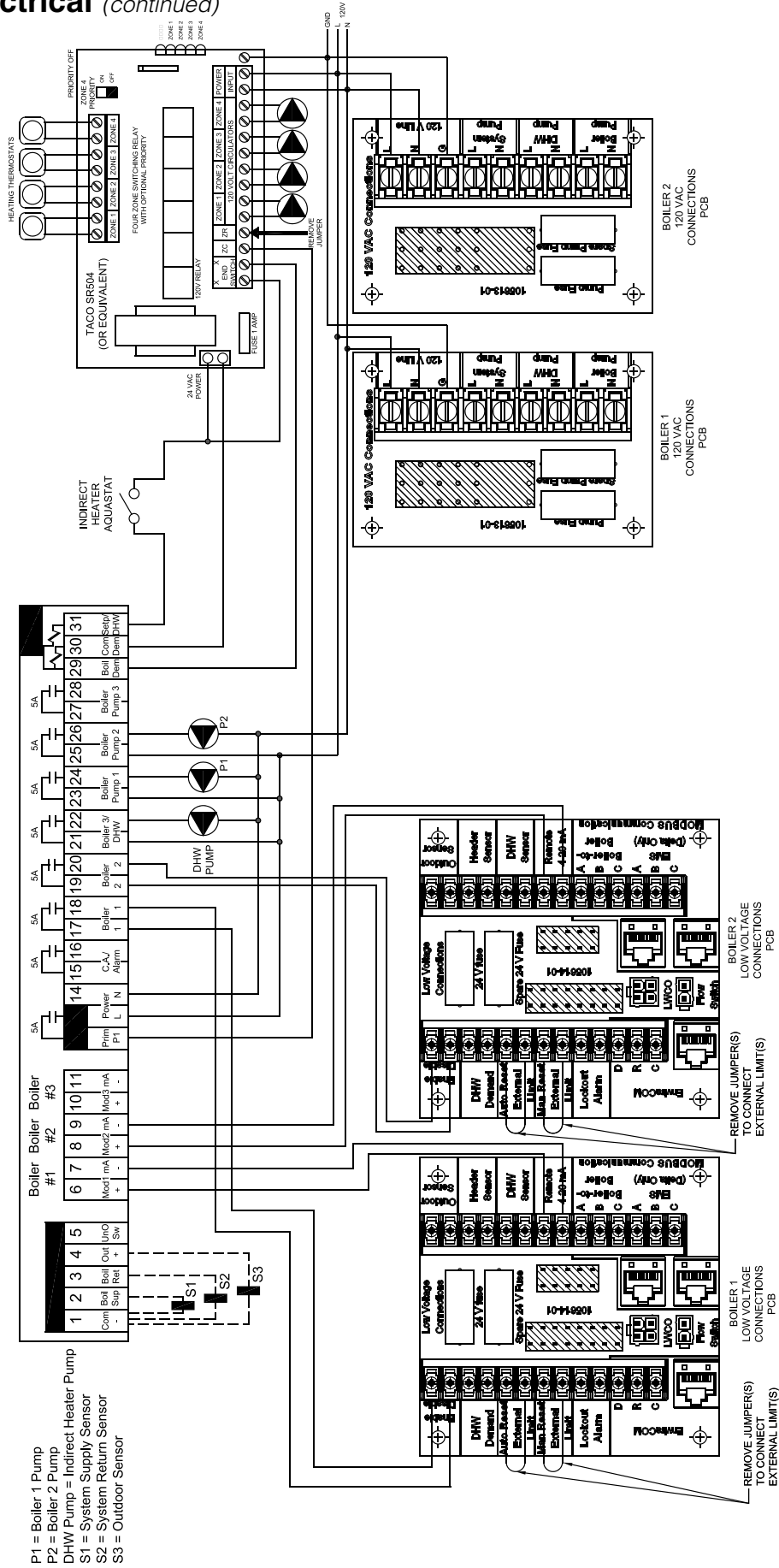

Figure 8-11: Multiple Boiler Wiring Diagram w/Tekmar 265 Control
Tekmar 265 Based Control System (or equal)
Sequence of Operation

The Tekmar 265 Control (or equal) can control up to three (3) boilers and an Indirect Water Heater. When a call for heat is received by the Tekmar 265 Control, the control will fire either one or more boilers in either parallel or sequential firing mode to establish a required reset water temperature in the system supply main based on outdoor temperature. The boilers will modulate based on an Analog communication signal established between the Tekmar 265 Control and each boiler's control. The boiler(s) and system supply water temperature will be reset together to maintain the input that is needed to the system. When a call for Indirect Hot Water is generated to the Tekmar 265, the control will de-energize the zone pump control (ZC terminal), energize the Indirect pump and modulate the boiler firing to establish a setpoint temperature in the main for the Indirect Heater using Priority. The Tekmar 265 also controls each boiler's pump and a post-purge of leftover temperature in the boilers will occur at the end of the call for Indirect Hot Water.

8 Electrical (continued)

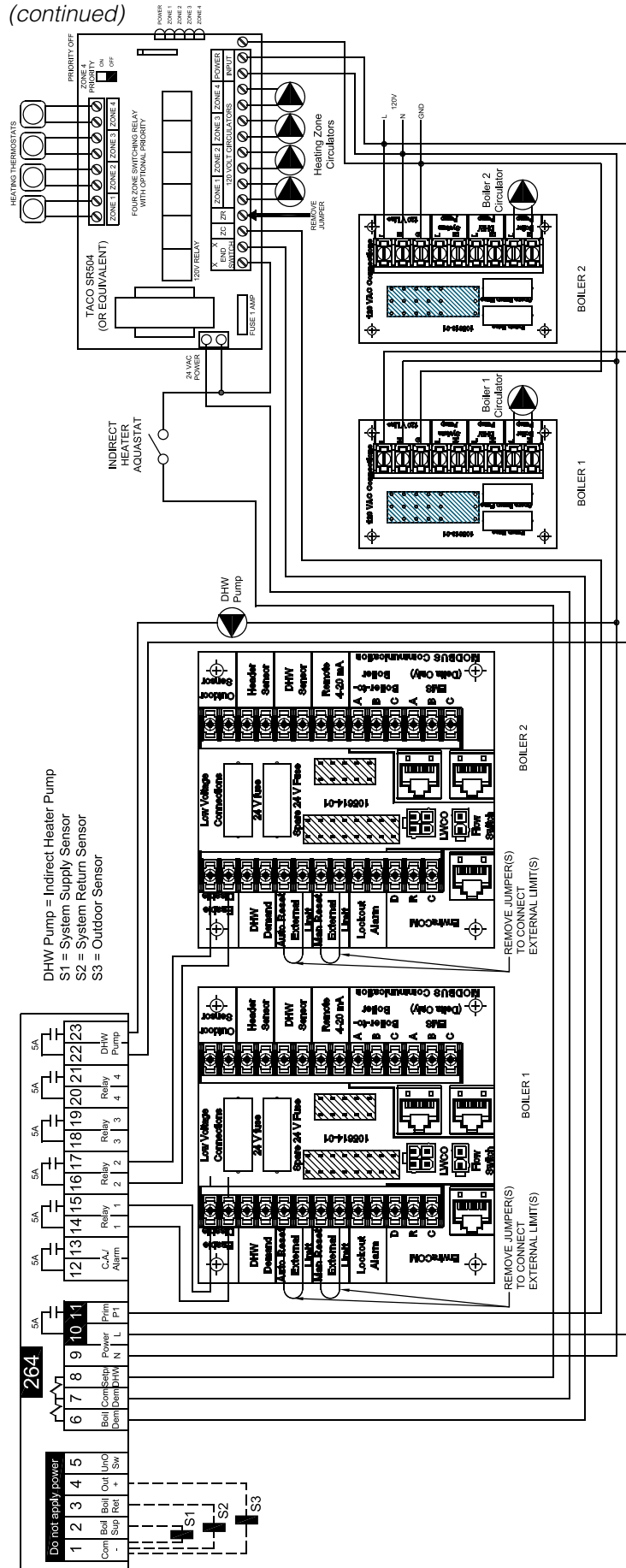

Figure 8-12: Multiple Boiler Wiring Diagram w/Tekmar 264 Control
Tekmar 264 Based Control System (or equal)
Sequence of Operation

The Tekmar 264 Control (or equal) can control up to four (4) boilers and an Indirect Water Heater by utilizing stage firing. When a call for heat is received by the Tekmar 264 Control, the control will fire either one or more boilers in sequential firing mode to establish a required reset water temperature in the system supply main based on outdoor temperature. The boilers will modulate on their own based on each boiler's control and will target a setpoint temperature to supply enough input to the system main to satisfy the desired reset water temperature in the main established by the Tekmar 264 Control. When a call for Indirect Hot Water is generated to the Tekmar 264, the control will de-energize the zone pump control (ZC terminal), energize the Indirect pump and sequentially fire the boilers to establish a setpoint temperature in the main for the Indirect Heater using Priority. The Tekmar 264 Control will disable the stage firing and post purge the Indirect Pump to reduce the temperature in the Supply Main near the end of the Indirect Mode to a point where it will need to be when it changes back to Space Heating Mode. The Tekmar 264 Control also has the ability to rotate the lead-lag firing of the boilers to establish equal operating time for each boiler stage.

8 Electrical *(continued)*

F. Multiple Boiler Wiring

1. **Install over-current protection** in accordance with authority having jurisdiction or, in the absence of such requirements, follow the National Electric Code, NFPA 70, and/or Canadian Electrical Code Part 1, CSA C22.1. Do not provide over-current protection greater than 15 amperes. If it becomes necessary to provide greater amperes (because of the number of boilers provided) use separate circuits and over-current protection for additional boilers.

2. Required Equipment and Setup

a. Header Sensor (P/N 101935-01 or 103104-01)

A header sensor must be installed and wired to the Sequencer Master boiler. The header sensor is installed on the common system piping and provides blended temperature information to the Sequence Master. Refer to Figure 6-16 for installation location and Figure 6-14 or 6-15 for installation detail.

b. Ethernet Cables

Ethernet cables are used to connect the boiler network together. These are standard “straight through” cables that can be purchased at electrical distributors.

Alternately, the network can be wired together by simply wiring Modbus Boiler-to-Boiler terminals A, B, and C between each boiler. Refer to Figures 8-5, 8-6, 8-9 and 8-10 for wiring location.

G. External Multiple Boiler Control System

As an alternate to the control internal sequencer, the control also accepts an input from an external sequencer. Follow multiple boiler control system manufacturer (Honeywell, Tekmar, etc.) instructions to properly apply a multiple boiler control system. The Tekmar Model 264 and Model 265 based control wiring diagrams (Figures 8-10 and 8-11) are provided as examples of typical multiple boiler control systems.

9 System Start-up

WARNING

Explosion Hazard. Asphyxiation Hazard. Electrical Shock Hazard. Start-up of this boiler should be undertaken only by trained and skilled personnel from a qualified service agency. Follow these instructions exactly. Improper installation adjustment, service or maintenance can cause property damage, personal injury or death.

A. Verify that the venting, water piping, gas piping and electrical system are installed properly.

Refer to installation instructions contained in this manual.

B. Confirm all electrical, water and gas supplies are turned off at the source and that vent is clear of obstructions.

C. Confirm that all manual shut-off gas valves between the boiler and gas source are closed.

D. Heating System Cleaning and Treatment

CAUTION

Component Damage.

Proper flushing, cleaning, and water side maintenance is highly recommended to protect boiler heat exchanger. Scaling and sediment build up may not be covered under warranty.

1. Flush entire heating system to remove sediment, flux, and traces of boiler additives
2. It is recommended to clean the heating system with an approved cleaner such as the following or an equivalent:
 - Fernox F3 Cleaner
 - Sentinel X400 System Restorer

Follow the manufactures instructions for proper dosage and use.

Note: Cleaning the system prior to removing the old boiler or by isolating the new boiler from the system while cleaning it will be more beneficial

3. Once a system is cleaned, use of an inhibitor is also recommended such as the following or an equivalent:
 - Fernox F1 Protector
 - Sentinel X100 Inhibitor

9 System Start-up *(continued)*

Follow the manufactures instructions for proper dosage, use. For long-term protection ensure concentration levels are maintained and checked annually as part of the boiler or system service.

4. Boiler system water should meet the following criteria. pH between 7.5 and 9.5.

If system contains aluminum components, pH must be less than 8.5.

Chlorides < 50 ppm.

Total Dissolved Solids - less than 2500 PPM.

Hardness - 3 to 9 grains/gallon.

Pressurize the system to at least 14.5 psi (100 kPa). Purge air from the system. A manual air vent is located on the right side of the heat exchanger inside the cabinet.

WARNING

Burn Hazard. The maximum operating pressure of this boiler is 30 psig (210 kPa), 50 psig (340 kPa), 60 psig (410 kPa), 80 psig (550 kPa) or 100 psig (689 kPa) depending on the model and safety relief valve option selected. Never exceed the maximum allowable working pressure on the heat exchanger ASME plate.

- E. Confirm that the boiler and system have no water leaks.**

NOTICE: If it is required to perform a long term pressure test of the hydronic system, the boiler should first be isolated to avoid a pressure loss due to the escape of air trapped in the boiler.

To perform a long term pressure test including the boiler, ALL trapped air must first be removed from the boiler.

A loss of pressure during such a test, with no visible water leakage, is an indication that the boiler contained trapped air.

- F. Check all gas piping for leaks** and purge piping sections that are filled with air. Refer to *National Fuel Gas Code*, ANSI Z223.1/NFPA 54 or, in Canada, *Natural Gas and Propane Installation Code*, CAN/CSA B149.1.

DANGER

Explosion Hazard. Do not use matches, candles, open flames or other ignition source to check for leaks. Make sure that the area around the boiler is clear and free from combustible materials, gasoline and other flammable vapors and liquids.

- G. Confirm vent system is complete** and free of obstructions before attempting to fire boiler.
- H. Inspect all wiring** for loose, uninsulated, or mis-wired connections.
- I. If boiler is to be converted to LP gas (propane),** convert as described in Part T of this section of the manual. Only models ALP399C and ALP500C can be converted to LP gas. Models ALP600C, ALP700C and ALP800C are factory built for LP gas and cannot be converted.
- J. If boiler is operating at elevations above 2,000 ft.,** see Appendix A for setup instructions.
- K. Start the boiler using operating instructions** in Figure 9-1. After the boiler is powered up with a call for heat, the boiler should go through the sequence of operation shown in Table 10-3.

9 System Start-up *(continued)*

FOR YOUR SAFETY READ BEFORE OPERATING/POUR VOTRE SECURITE LISEZ AVANT DE METTRE EN MARCHÉ

WARNING: If you do not follow these instructions exactly, a fire or explosion may result causing property damage, personal injury or loss of life.

AVERTISSEMENT: Quiconque ne respecte pas à la lettre les instructions dans la présente notice risque de déclencher un incendie ou une explosion entraînant des dommages, des blessures ou la mort.

- A. This appliance does not have a pilot. It is equipped with an ignition device which automatically lights the burner. Do **not** try to light the burner by hand.
- B. BEFORE OPERATING smell all around the appliance area for gas. Be sure to smell next to the floor because some gas is heavier than air and will settle on the floor.

WHAT TO DO IF YOU SMELL GAS:

- Do not try to light any appliance.
 - Do not touch any electric switch; do not use any phone in your building.
 - Immediately call your gas supplier from a neighbor's phone. Follow the gas supplier's instructions.
 - If you cannot reach your gas supplier, call the fire department.
- C. Use only your hand to turn the gas control knob. Never use tools. If the knob will not turn by hand, don't try to repair it, call a qualified service technician. Force or attempted repair may result in a fire or explosion.
- D. Do not use this appliance if any part has been under water. Immediately call a qualified service technician to inspect the appliance and to replace any part of the control system and any gas control which has been under water.

- A. Cet appareil ne comporte pas de veilleuse. Il est muni d'un dispositif d'allumage qui allume automatiquement le brûleur. Ne tentez pas d'allumer le brûleur manuellement.

- B. AVANT DE FAIRE FONCTIONNER, reniflez tout autour de l'appareil pour déceler une odeur de gaz. Reniflez près du plancher, car certains gaz sont plus lourds que l'air et peuvent s'accumuler au niveau du sol.

QUE FAIRE SI VOUS SENTEZ UNE ODEUR DE GAZ:

- Ne pas tenter d'allumer d'appareil.
 - Ne touchez à aucun interrupteur ; ne pas vous servir des téléphones se trouvant dans le bâtiment.
 - Appelez immédiatement votre fournisseur de gaz depuis un voisin. Suivez les instructions du fournisseur.
 - Si vous ne pouvez rejoindre le fournisseur, appelez le service des incendies.
- C. Ne poussez ou tournez la manette d'admission du gaz qu'à la main ; ne jamais utiliser d'outil. Si la manette reste coincée, ne pas tenter de la réparer ; appelez un technicien qualifié. Le fait de forcer la manette ou de la réparer peut déclencher une explosion ou un incendie.
- D. N'utilisez pas cet appareil s'il a été plongé dans l'eau, même partiellement. Faites inspecter l'appareil par un technicien qualifié et remplacez toute partie du système de contrôle et toute commande qui ont été plongés dans l'eau.

OPERATING INSTRUCTIONS/ INSTRUCTIONS DE FONCTIONNEMENT

1. STOP! Read safety information above on this label.
2. Set the thermostat to lowest setting.
3. Turn off all electric power to the appliance.
4. This appliance is equipped with an ignition device which automatically lights the burner. Do **not** try to light the burner by hand.
5. Turn the external boiler manual gas valve handle clockwise ↻ to close the gas supply.
6. Wait five (5) minutes to clear out any gas. Then smell for gas, including near the floor. If you smell gas, STOP! Follow "B" in the safety information above on this label. If you don't smell gas, go to the next step.
7. Turn the external boiler manual gas valve handle counterclockwise ↻ to open the gas supply.
8. Turn on all electric power to the appliance.
9. Set the thermostat to the desired setting.
10. If the appliance will not operate, follow the instructions "To Turn Off Gas To Appliance" and call your service technician or gas supplier.

1. ARRÊTEZ ! Lisez les instructions de sécurité sur la portion supérieure cette étiquette.
2. Réglez le thermostat à la température la plus basse.
3. Coupez l'alimentation électrique de l'appareil.
4. Cet appareil est équipé de l' dispositif d'allumage qui allume automatiquement le brûleur. Ne tentez pas d'allumer le brûleur manuellement.
5. Tourner la chaudière externe manuelle poignée ↻ en clapet à gaz dans le sens des aiguilles d'une montre pour fermer l'offre de gaz.
6. Attendre cinq (5) minutes pour laisser échapper tout le gaz. Reniflez tout autour de l'appareil, y compris près du plancher, pour déceler une odeur de gaz. Si vous sentez une odeur de gaz, ARRÊTEZ ! Passez à l'étape B des instructions de sécurité sur la portion supérieure de cette étiquette. S'il n'y a pas d'odeur de gaz, passez à l'étape suivante.
7. Tourner la chaudière externe manuelle compteur de poignée ↻ en clapet à gaz ouvrir dans le sens des aiguilles d'une montre le gaz approvisionnement.
8. Mettez l'appareil sous tension.
9. Réglez le thermostat à la température désirée.
10. Si l'appareil ne se met pas en marche, suivez les instructions intitulées « Comment couper l'admission de gaz de l'appareil » et appelez un technicien qualifié ou le fournisseur de gaz.

OPEN/OUVERT

CLOSED/FERMÉ

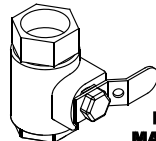
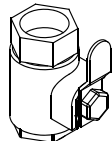

EXTERNAL BOILER
MANUAL GAS VALVE
LA CHAUDIÈRE EXTERNE
MANUELLE DE CLAPET À GAZ

TO TURN OFF GAS TO APPLIANCE/ COMMENT COUPER L'ADMISSION DE GAZ DE L'APPAREIL

1. Set the thermostat to lowest setting.
2. Turn off all electric power to the appliance if service is to be performed.
3. Turn the external boiler manual gas valve handle clockwise ↻ to close gas supply.

1. Réglez le thermostat à la température la plus basse.
2. Coupez l'alimentation électrique de l'appareil s'il faut procéder à l'entretien.
3. Tourner la chaudière externe manuelle poignée ↻ en clapet à gaz dans le sens des aiguilles d'une montre pour fermer l'offre de gaz.

Figure 9-1: Operating Instructions

9 System Start-up *(continued)*

L. Upon initial start-up, the gas train will be filled with air. Even if the gas line has been completely purged of air, it may take several tries for ignition before a flame is established. If more than 2 tries for ignition are needed, it will be necessary to press the reset button to restart the boiler. Once a flame has been established for the first time, subsequent calls for burner operation should result in a flame on the first try.

M. Check Burner Flame

Inspect the flame visible through the window. On high fire the flame should be stable and mostly blue (Figure 9-4). No yellow tipping should be present; however, intermittent flecks of yellow and orange in the flame are normal.

N. Check Gas Inlet Pressure

Check the inlet pressure and adjust if necessary. Verify that the inlet pressure is between the upper and lower limits shown on the rating plate with all gas appliances on and off.

WARNING

Asphyxiation Hazard. The outlet pressure for the gas valve has been factory set and requires no field adjustment. This setting is satisfactory for both natural gas and propane. Attempting to adjust the outlet pressure may result in damage to the gas valve and cause property damage, personal injury or death.

O. Perform Combustion Test

WARNING

Asphyxiation Hazard. Each Alpine Series boiler is tested at the factory and adjustments to the air fuel mixture are normally not necessary. Improper gas valve or mixture adjustments could result in property damage, personal injury or death.

WARNING

Any gas valve adjustments (throttle and/or offset) specified herein and subsequent combustion data (%O₂, %CO₂, CO air free ppm) collection must be performed using a calibrated combustion analyzer. Failure to use combustion analyzer could result in property damage, personal injury or death.

- 1. Use a combustion analyzer** to sample boiler flue gas and measure O₂ (or CO₂) and CO air free. Boilers are equipped with a screw cap in the vent connector. Be sure to replace this cap when combustion testing complete.
- 2. Verify O₂ (or CO₂) and CO air free are within limits** specified in Table 9-2 for natural gas or Table 9-3 for LP gas (propane). **Note:** Tables 9-2 and 9-3 are for sea level only. For altitudes above 2,000 ft., see Appendix A.
 - Lock boiler in high fire and allow fan speed and combustion analyzer reading to stabilize before taking combustion readings. To lock boiler in high fire, from the home screen, press "Adjust", "Adjust", "Login", "000". Enter the password "086" and press return arrow to close the key pad. Press "Save", "Adjust", "High" to lock boiler in high fire.

Table 9-2: Natural Gas Typical Combustion Readings (Sea level Only)

Boiler Model	CO ₂ %	O ₂ %	CO air free (PPM)
ALP399C	8.6 - 9.2	4.7 - 5.8	Less than 200 PPM
ALP500C	8.7 - 9.2	4.7 - 5.6	
ALP600C	8.6 - 9.2	4.7 - 5.6	
ALP700C	8.2 - 8.9	5.2 - 6.5	
ALP800C	8.2 - 9.1	4.9 - 6.5	

Table 9-3: LP Gas (Propane) Typical Combustion Readings (Sea Level Only)

Boiler Model	CO ₂ %	O ₂ %	CO air free (PPM)
ALP399C	9.4 - 10.2	5.4 - 6.6	Less than 200 PPM
ALP500C	9.8 - 10.2	5.4 - 6.0	
ALP600C	9.4 - 10.2	5.4 - 6.6	
ALP700C	9.7 - 10.0	5.7 - 6.2	
ALP800C	9.4 - 10.2	5.4 - 6.6	

9 System Start-up *(continued)*

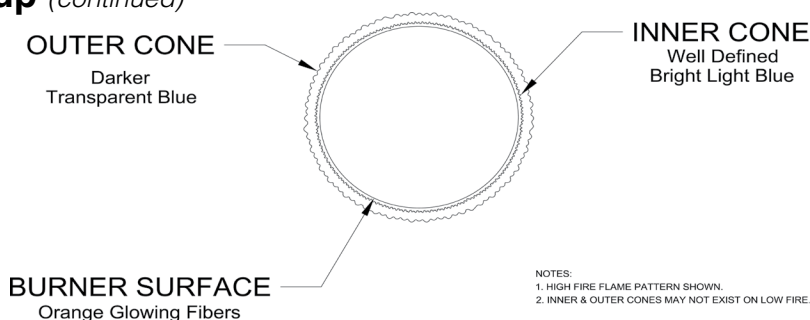

Figure 9-4: Burner Flame

⚠ WARNING

Make sure that all adjustments at high fire are made with the throttle, not offset screw (see Figure 9-5). The offset screw has been factory set using precision instruments and must never be adjusted in the field unnecessarily. Attempting to adjust the offset screw unnecessarily could result in damage to the gas valve and may cause property damage, personal injury or death.

- b. If high fire O_2 is too low (CO_2 is too high), increase O_2 (decrease CO_2) by turning the throttle screw clockwise in 1/4 turn increments and checking the O_2 (or CO_2) after each adjustment. If boiler is equipped with 2 gas valves, throttle screw adjustments must be done to both gas valves equally and simultaneously. Refer to Figure 9-5 for location of throttle screw. Verify CO air free is less than 200 ppm.
- c. If high fire O_2 is too high (CO_2 is too low), decrease O_2 (increase CO_2) by turning the throttle screw counter-clockwise in 1/4 turn increments and checking the O_2 (or CO_2) after each adjustment. If boiler is equipped with 2 gas valves, throttle screw adjustments must be done to both gas valves equally and simultaneously. Refer to Figure 9-5 for location of throttle screw. Verify CO air free is less than 200 ppm.
- d. Lock boiler in low fire and allow fan speed and combustion analyzer reading to stabilize before taking combustion readings. Press "Low" to lock boiler in low fire.

⚠ WARNING

Asphyxiation Hazard. Offset screw is adjusted at the factory to the specification. DO NOT touch the offset screw if measured low fire O_2 (or CO_2) is within limits specified in Table 9-2 or 9-3.

- e. If low fire O_2 is too low (CO_2 is too high), increase O_2 (decrease CO_2) by turning offset screw counterclockwise in less than 1/8 turn increments and checking the O_2 (or CO_2) after each adjustment. If boiler is equipped with 2 gas valves, offset screw adjustments must be done to both gas valves equally and simultaneously. Refer to Figure 9-5 for location of offset screw. Verify CO air free is less than 200 ppm.
- f. If low fire O_2 is too high (CO_2 is too low), decrease O_2 (increase CO_2) by turning offset screw clockwise in less than 1/8 turn increments and checking the O_2 (or CO_2) after each adjustment. If boiler is equipped with 2 gas valves, offset screw adjustments must be done to both gas valves equally and simultaneously. Refer to Figure 9-5 for location of offset screw. Verify CO air free is less than 200 ppm.

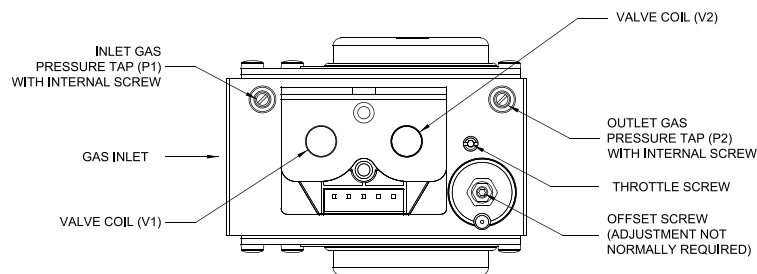

Figure 9-5: Gas Valve Detail

3. **Remove analyzer probe** and replace cap on boiler vent connector.
4. **Return boiler to Automatic Mode.** Press "Auto".

P. Test Safety Limits Controls

1. **Test the ignition system safety shut-off** by disconnecting the flame sensor connector (black plug with orange wire) from the flame ionization electrode. See Figure 8-5. The boiler must shut down and must not start with the flame sensor disconnected.

9 System Start-up *(continued)*

2. **Test the flow switch** by disabling the primary loop circulator. The boiler must not start if flow is not present.
3. **Test any other external limits** or other controls in accordance with the manufacturer's instructions.

Q. Check Thermostat Operation

Verify that the boiler starts and stops in response to calls for heat from the heating thermostat and indirect water heater thermostat. Make sure that the appropriate circulators also start and stop in response to the thermostats.

R. Adjust Supply Water Temperature

As shipped, the heating set point supply temperature is set to 180°F (82.2°C) and, indirect water heater set point supply temperature is set to 170°F (76.7°C). If necessary, adjust these to the appropriate settings for the type of system to which this boiler is connected. See Section 10 "Operation" (Central Heat parameter table) of this manual for information on how to adjust supply setpoint.

S. Adjust Thermostats

Adjust the heating and indirect water heater thermostats to their final set points.

T. Field Conversion From Natural Gas to LP Gas (Propane)

Alpine models ALP399C and ALP500C are factory shipped as natural gas builds and can be field converted to LP gas. Follow steps below for field conversion from natural gas to LP Gas.

Models ALP600C, ALP700C and ALP800C are factory shipped as either natural gas build or LP gas build. Field conversions of models ALP600C, ALP700C and ALP800C are not permitted.

1. **Conversion** of Alpine models ALP399C and ALP500C from one fuel to another is accomplished using the throttle screw on the gas valve. Figure 9-5 "Gas Valve Detail" shows the location of the throttle screw on the valve. Locate the throttle screw on the boiler being converted.

⚠ WARNING

Explosion Hazard. Asphyxiation Hazard.

This conversion should be performed by a qualified service agency in accordance with the manufacturer's instructions and all applicable codes and requirements of the authority having jurisdiction. If the information in these instructions is not followed exactly, a fire, an explosion or production of carbon monoxide may result causing property damage, personal injury, or death. The qualified service agency is responsible for proper conversion of these boilers. The conversion is not proper and complete until the operation of the converted appliance is checked as specified in this manual.

2. **If conversion is being made on a new installation**, install the boiler in accordance with the installation instructions supplied with the boiler. If an installed boiler is being converted, connect the new gas supply to the boiler, check for gas leaks, and purge the gas line up to the boiler in accordance with the *National Fuel Gas Code*, ANSI Z223.1/NFPA 54 and/or *Natural Gas and Propane Installation Code*, CAN/CSA B149.1 or the requirements of the authority having jurisdiction.
3. **Before attempting to start the boiler**, make the number of turns to the throttle screw called for in Table 9-6.
4. **Start the boiler using operating instructions** in Figure 9-1. After the boiler is powered up with a call for heat, the boiler should go through the sequence of operation shown in Table 10-3. Even if the gas line has been completely purged of air, it may take several tries for ignition before a flame is established. If more than 2 tries for ignition are needed, it will be necessary to press the reset button to restart the boiler. If boiler does not light, turn the throttle screw counter-clockwise in 1/4 turn increments, allowing the boiler to make at least three tries for ignition at each setting, until the boiler lights.

Table 9-6: Approximate Clockwise Throttle Screw Turns for LP Gas (Propane) Conversion

Boiler Model	Approximate Throttle Screw Turns
ALP399C	2¾
ALP500C	3
ALP600C	N/A - Factory LP Builds
ALP700C	
ALP800C	

9 System Start-up *(continued)*

WARNING

Asphyxiation Hazard. The throttle adjustments shown in Table 9-6 are approximate. The final throttle setting must be found using a combustion analyzer. Leaving the boiler in operation with a CO air free level in excess of 200 ppm could result in injury or death from carbon monoxide poisoning.

5. **After the burner lights**, complete all steps outlined in Paragraph O “Perform Combustion Test” before proceeding.

WARNING

Asphyxiation Hazard. These instructions include a procedure for adjusting the air-fuel mixture on this boiler. This procedure requires a combustion analyzer to measure the O₂ (or CO₂) and Carbon Monoxide (CO air free) levels in flue gas. Adjusting the air-fuel mixture without a proper combustion analyzer could result in unreliable boiler operation, personal injury, or death due to carbon monoxide poisoning.

6. **Verify** that the gas inlet pressure is between the upper and lower limits shown in Table 7-6 with all gas appliances (including the converted boiler) both on and off.
7. **A label sheet is provided** with the boiler for conversions from natural gas to LP gas. Once conversion is completed, apply labels as follows:
 - a. Apply the “Rating Plate Label” adjacent to the rating plate.
 - b. Apply the “Gas Valve Label” to a conspicuous area on the gas valve.
 - c. Apply the “Boiler Conversion Label” to a conspicuous surface on, or adjacent to, the outer boiler jacket. Fill in the date of the conversion and the name and address of the company making the conversion with a permanent marker.

U. Correcting Throttle Screw Mis-Adjustment

(if required)

Alpine boilers are fire tested at factory and gas valve throttle screws are preset. However, if boiler does not start when first turned on, and, the problem cannot be remedied following “Help” prompts on the boiler control display, it may be necessary to reset and readjust the throttle screw according to the following instructions.

1. **Fully close throttle** by turning throttle screw clockwise until it fully stops.
2. **Open throttle screw** counter-clockwise the number of full (360 degrees) and partial turns listed in Table 9-7 for natural gas or Table 9-8 for LP gas.
3. **Follow instructions in Paragraph O** “Perform Combustion Test” to verify O₂ (or CO₂) is within the range specified in Table 9-2 for natural gas or Table 9-3 for LP gas at both high fire and low fire.

WARNING

The throttle adjustment values shown in Table 9-7 and Table 9-8 are approximate. The final throttle setting must be found using a combustion analyzer.

Table 9-7: Approximate Counter-Clockwise Throttle Screw Turns from Fully Closed Position, Natural Gas

Boiler Model	Approximate Throttle Screw Turns
ALP399C	5¾
ALP500C	6½
ALP600C	6½
ALP700C	10½
ALP800C	11

Table 9-8: Approximate Counter-Clockwise Throttle Screw Turns from Fully Closed Position, LP Gas (Propane)

Boiler Model	Approximate Throttle Screw Turns
ALP399C	3
ALP500C	3½
ALP600C	8
ALP700C	12
ALP800C	8½

9 System Start-up *(continued)*

WARNING

Asphyxiation Hazard. If the throttle is very far out of adjustment on the “rich” (counter-clockwise) side, the boiler burner may be running at 0% excess air or even with air deficiency. Operating the boiler in this condition may cause property damage, personal injury or death. At 0% excess air the CO₂ readings will be either 11.9% CO₂ for natural gas or 13.8% CO₂ for LP gas (O₂ will be 0%) and CO air free level will be extremely high (well over 1000 PPM).

If the burner operates with air deficiency, the following phenomena may be observed:

% CO₂ will actually drop (% O₂ will increase) as the throttle is turned counter-clockwise

% CO₂ will actually increase (% O₂ will drop) as the throttle is turned clockwise

If the boiler appears to operate with air deficiency, shut down the boiler and follow instructions in Paragraph U “Correcting Throttle Screws Mis-Adjustment. Then, use a combustion analyzer to verify and adjust O₂ (or CO₂) and CO air free to values shown in Table 9-2 for natural gas or Table 9-3 for LP gas.

V. Controls Start-up Check List

Check field wiring and control parameters per below Table 9-9 and Table 9-10. The control is factory programmed with default parameters. Review parameters and adjust as necessary to conform to specific site requirements. From Home Screen, select ADJUST to access below listed parameters. Login as needed to make changes. For detailed login instructions, refer to Section 10 “Operation”, Paragraph F “Changing Adjustable Parameters”.

Table 9-9: Field Wiring Checklist

Step	Wiring Location	Parameter	Description
1	120V PCB	120V Line	Is line voltage connected with overcurrent protection?
		Boiler, System, and DHW Pumps	Confirm pumps are connected. If using room air for combustion, confirm combustion air damper is connected.
2	Low Voltage Connections PCB	Enable/Disable	Is the space heating thermostat connected. Ensure thermostat is a “dry”, non-powered input.
		DHW Demand	Is an indirect water heater (IWH) providing a heat demand?
		Auto Reset and Man Reset External Limit	Are external limits used? If so, ensure jumper is removed and limits properly connected. Also check that external limits are closed and any manual reset devices are reset.
		Lockout Alarm	Are alarm contacts connected?
		EnviraCOM	Are any EnviraCOM devices used?
		Outdoor Sensor	Is an outdoor sensor used? Refer to Steps 1 & 7 in Table 9-10.
		Header Sensor	Is a header sensor used? A header sensor is required for the master boiler in a multiple boiler installation. Refer to Step 8 in Table 9-10 to activate this input.
		DHW Sensor	For single boiler servicing indirect water heater (IWH), install DHW Sensor at boiler-side inlet to IWH. Refer to Step 6 in Table 9-10 to activate this input.
		Remote 4-20mA	Is a 4-20mA input required for: 1) modulation input from an energy management system, or 2) Central Heat setpoint input from external multiple boiler control? If yes, refer to Step 11 in Table 9-10.
		Boiler-to-Boiler	Are multiple boilers connected? If yes, refer to Steps 8 & 9 in Table 9-10 to activate boiler-to-boiler communication.
		EMS	Is the boiler connected to an energy management system? If yes, refer to Step 10 in Table 9-10.
Flow Switch	Is flow switch installed in piping and plugged in?		
LWCO	Is a 24V LWCO used? Check installation.		

9 System Start-up *(continued)*

Table 9-10: Control Parameter Checklist

Step	Parameter Location	Parameter	Description
1	Adjust >> System Setup	Outdoor Sensor Source	Select appropriate source: Not Installed, Wired or Wireless.
		Warm Weather Shutdown Enable/Disable	Selecting Enable will restrict boiler start during warm weather, but only if an outdoor sensor is installed.
2	Adjust >> Modulation Setup	Boiler Type	WARNING! Confirm correct boiler model is shown. Stop installation and contact factory if incorrect boiler model is shown.
3	Adjust >> Pump Setup	Boiler Circulator	Ensure pump parameter selections are correct for your application.
		System Circulator	
		Domestic Circulator	
4	Adjust >> Contractor Setup	Contractor Name	Enter contact information. In the event of a fault, or the need to adjust a setting, the display will direct the user to the entered contact.
		Contractor Address	
		Contractor Phone	
5	Adjust >> Central Heat	Setpoint	Ensure target space heating water temperature (Setpoint) is correct for your type of radiation.
6	Adjust >> Domestic Hot Water	Setpoint	Ensure target domestic hot water temperature (Setpoint) is correct.
		DHW Modulation Sensor	If using DHW Sensor, select DHW Sensor.
7	Adjust >> Outdoor Reset Central Heat	Enable/Disable	If not using an outdoor sensor, select Disable.
8	Adjust >> Sequencer Master	Sequencer Master	If boiler is the master boiler in a multiple boiler installation, select Enable.
9	Adjust >> Sequencer Slave	Boiler Address	If boiler is a slave boiler in a multiple boiler installation, assign a unique boiler address.
10	Adjust >> Energy Management	Demand Source	If boiler is connected to an energy management system, and demand will be through Modbus terminals, select Modbus. NOTE: Disable boiler internal sequencer when connecting to an energy management system.
11	Adjust >> Energy Management	Central Heat Modulation Source	If using an external multiple boiler controller, set to 4-20 mA.
		Central Heat Boiler Setpoint Source	If an Energy Management System is sending a remote setpoint to the boiler, set to 4-20 mA.

10 Operation

A. Overview

1. Sage2.2 Controller

The Sage2.2 Controller (Control) contains features and capabilities which help improve heating system operation, and efficiency. By including unique capabilities, the Control can do more with less field wiring and fewer aftermarket controls and components – improving the operation of both new and replacement boiler installations.

2. Advanced Touch Screen Display

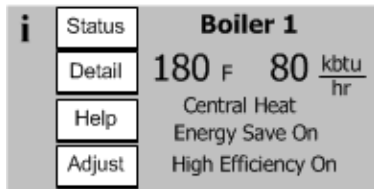

Home Screen

Boiler status and setup selections are available from an easy to use, dual color, LCD Touch Screen Display. Over one hundred helpful information screens are provided to explain status information and setup functions. In the event of a fault condition the user is guided by “blinking” touch buttons to Help screens that explain the problem cause and corrective action. Operation evaluation and problem-solving is enhanced by historical capability including graphic trends, lockout history records as well as boiler and circulator cycle counts and run time hours.

3. Advanced Modulating Control

The Control modulates the boiler input by varying the fan speed. As the fan speed increases, so does the amount of fuel gas drawn into the blower. As a result, a fairly constant air-fuel ratio is maintained across all inputs. The Control determines the input needed by looking at both current and recent differences between the measured temperature and the setpoint temperature. As the measured temperature approaches the setpoint temperature, the fan will slow down and the input will drop. The Control also utilizes boiler return water and flue gas temperatures to adjust fan speed.

4. HeatMatch™ Software

When the boiler is installed with a Sage Zone Control Panel (Zone Control) into a multiple zone home the Control uses a patent pending HeatMatch Software to improve home comfort, increase component life and save energy. The Sage2.2 Controller with the Zone Control detects active (turned “on”) zones, totals btu/hrs expected and limits the boiler firing rate to “match” actual home demand. Instead of simply firing to 100% in response to a cold supply water temperature

the Control combines heat matching with supply water temperature control. The result is longer run times, dramatic reduction in boiler excessive cycling and higher operating efficiency. Avoiding extra cycling saves customer fuel dollars (pre and post purge sends heat up stack) and saves wear and tear on the boiler. Lowering the boiler’s firing rate saves fuel dollars by increasing the amount of flue gas condensation, which is always the goal of condensing boiler installations.

5. Built-in Safety Control

The Control includes safety controls designed to ensure safe and reliable operation. In addition to flame safety controls, the Control includes supply water temperature, differential water temperature, and stack temperature safety limits and stepped modulation responses. Boiler modulation is adjusted when required to help avoid loss of boiler operation due to exceeding limits. Additionally, the Control accepts the field installation of optional auxiliary safety limits.

6. Outdoor Air Reset

When selected the modulation rate setpoint is automatically adjusted based on outside air temperature, time of day and length of demand (boost) settings. Outdoor air “reset” setpoint saves fuel by adjusting the water temperature of a heating boiler lower as the outside air temperature increases.

7. Warm Weather Shutdown (WWSD)

Some boilers are used primarily for heating buildings, and the boilers can be automatically shutdown when the outdoor air temperature is warm. When outside air temperature is above the WWSD setpoint, this function will shut down the boiler and system pump.

8. Energy Management System (EMS) Interface

The Control accepts a 4-20mADC input from the EMS system for either direct modulation rate or setpoint.

A factory configured RS485 Modbus interface is available for Energy Management System (EMS) monitoring when not used for Multiple Boiler Sequencer Peer-To-Peer Network. Consult factory if this interface must be used in addition to the boiler Peer-to-Peer Network.

9. Circulator Control

The Control may be used to sequence the domestic hot water, boiler and system circulators. Service rated relay outputs are wired to a line voltage terminal block for easy field connection. Simple parameter selections allow all three pumps to respond properly to various hydronic piping arrangements including either a boiler or

10 Operation B. Supply Water Temperature Regulation *(continued)*

primary piped indirect water heater. Circulators are automatically run for a 20 second exercise period after not being used for longer than 7 days. Circulator exercise helps prevent pump rotor seizing.

10. Multiple Boiler Sequencer Peer-To-Peer Network

The Control includes a state-of-the-art modulating lead-lag sequencer for up to eight (8) boilers capable of auto rotation, outdoor reset and peer-to-peer communication. The peer-to-peer network is truly “plug and play”. Communication is activated by simply connecting a RJ45 ethernet cable between boilers. The Control provides precise boiler coordination by sequencing boilers based on both header water temperature and boiler modulation rate. For example, the lead boiler can be configured to start a lag boiler after operating at 50% modulation rate for longer than an adjustable time. The boilers are modulated in “unison” (parallel) modulation rate to ensure even heat distribution.

11. Modbus Communication Interface

A factory configured RS485 Modbus interface is available for Energy Management System (EMS) monitoring when not used for Multiple Boiler Sequencer Peer-To-Peer Network. Consult factory if this interface must be used in addition to the boiler Peer-to-Peer Network.

B. Supply Water Temperature Regulation

1. Priority Demand

The Control accepts a call for heat (demand) from multiple places and responds according to its “Priority”. When more than 1 demand is present the higher priority demand is used to determine active boiler settings. For example, when Domestic Hot Water (DHW) has priority the setpoint, “Diff Above”, “Diff Below” and pump settings are taken from DHW selections. Active “Priority” is displayed on the “Boiler Status” screen.

2. Setpoint Purpose

The Control starts and stops the boiler and modulates the boiler input from minimum (MBH) to maximum (MBH) in order to heat water up to the active setpoint. The setpoint is determined by the priority (Central Heat or Domestic Hot Water) and as described in the following paragraphs.

3. Central Heat Setpoint

Upon a Central Heat call for heat the setpoint is either the user entered Central Heat Setpoint, or is automatically adjusted by a thermostat’s “Sleep” or “Away” modes and/or Outdoor Air Reset or, an Energy Management System (EMS) supplied 4-20mADC setpoint.

Table 10-1: Order of Priority

Priority	Status Screen Display	Boiler Responding to:
1st	Sequencer Control	The boiler is connected to the peer-to-peer network. The boiler accepts demand from the Sequencer Master.
2nd	Domestic Hot Water	DHW call for heat is on and selected as the priority demand. DHW is always higher priority than Central Heat. It also has higher priority than the Sequencer Control when DHW priority is “enabled” and “Boiler Piped” IWH is selected.
3rd	Central Heat	Central Heat call for heat is on and there is no DHW demand or DHW priority time has expired.
4th	Auxiliary Heat	Auxiliary Heat call for heat is on and there is no Central Heat or DHW demand. (NOTE: May be user selected to be higher priority than Central Heat.)
5th	Frost Protection	Frost Protection is active and there is no other call for heat. Frost protection will be a higher priority than Sequencer Control if the Sequence Master has no active call for heat.
6th	Warm Weather Shutdown (WWSD)	WWSD is active and the boiler will not respond to central heat demands. DHW demand is not blocked by WWSD.
7th	Standby	There is no demand detected.

4. Auxiliary Heat Setpoint

Auxiliary Heat is a second heating demand that may be used to serve either lower temperature radiation or warmer heat demands such as fan coils. Upon an Auxiliary Heat call for heat the setpoint is either the user entered Auxiliary Heat Setpoint or is automatically adjusted as a thermostat’s “sleep” or, Away Modes or, Outdoor Air Reset.

5. Outdoor Air Reset

If an outdoor temperature sensor is connected to the boiler and Outdoor Reset is enabled, the Central Heat and Auxiliary Heat setpoints will automatically adjusted downwards as the outdoor temperature increases. When the water temperature is properly matched to heating needs there is minimal chance of room air temperature overshoot. Excessive heat is not sent to the room heating elements by “overheated” (supply water temperature maintained too high a setting) water. Reset control saves energy by reducing room over heating, reducing boiler temperature, increasing combustion efficiency, and reducing standby losses as a boiler and system piping cool down to ambient following room over heating.

6. Boost Time

When the Central Heat Setpoint is decreased by Outdoor Air Reset settings the Boost function can be enabled to increase the setpoint in the event

10 Operation C. Boiler Protection Features *(continued)*

that central heat demand is not satisfied for longer than the Boost Time setpoint. The Boost feature increases the operating temperature setpoint by 10°F (5.6°C) every 20 minutes (field adjustable) the central heat demand is not satisfied. This process will continue until heat demand is satisfied (indoor air is at desired temperature). Once the heat demand is satisfied, the operating setpoint reverts to the value determined by the Outdoor Air Reset settings. If Boost Time is zero, then the boost function is not used.

7. Domestic Hot Water (DHW) Setpoint

Upon a DHW call for heat the setpoint is either the user entered DHW setpoint or the Thermostat's "Sleep" or "Away" DHW setpoint. The optimal value of this setpoint is established based on the requirements of the indirect water heater.

8. Domestic Hot Water Priority (DHWP)

Some boilers are used primarily for building space heating, but also provide heat for the domestic hot water users. When the outdoor temperature is warm, the outdoor reset setpoint may drop lower than a desirable domestic hot water temperature. Also, often it is required to quickly recover the indirect water heater. When DHWP is enabled, heating circulators are stopped, the domestic circulator is started and the domestic hot water setpoint is established in response to a domestic hot water demand. Priority protection is provided to allow the heating loop to be serviced again in the event of an excessively long domestic hot water call for heat.

9. "Setback" Setpoints

User adjustable Thermostat "Sleep" or "Away" Setback Setpoints are provided for both Central Heat and DHW demands. The Setback setpoint is used when the EnviraCOM thermostat is in "leave" or "sleep" modes. When setback is "on", the thermostat setback setpoint shifts the reset curve to save energy while the home is in reduced room temperature mode. The Honeywell VisionPro IAQ (part number TH9421C1004) is a "setback" EnviraCOM enabled thermostat.

C. Boiler Protection Features

1. Supply Water Temperature High Limit

The boiler is equipped with a UL 353 listed boiler control and UL 1434 listed high limit sensor. Response to supply temperature is as follows:

- Supply exceeds 190°F (87.7°C) – output (fan speed) reduced
- Supply exceeds 200°F (93.3°C) – recycle
- Supply exceeds 210°F (98.9°C) – manual reset hard lockout

Additionally, a soft lockout occurs if the supply temperature rises to fast (i.e. faster than the degrees Fahrenheit per second limit).

2. High Limit Differential Temperature Limit

The control monitors temperature difference between return and supply sensors. Response to temperature difference is as follows.

- Differential exceeds 43°F (23.9°C) – output (fan speed) reduced
- Differential exceeds 53°F (29.4°C) – recycle
- Differential exceeds 63°F (35°C) – shutdown; automatic restart after temperature difference has decreased and minimum off time has expired

3. Flue Temperature High Limit

The control monitors flue gas temperature sensor located in vent outlet at rear of heat exchanger. Response to flue temperature is as follows:

- Flue exceeds 184°F (84.4°C) – output (fan speed) is reduced
- Flue exceeds 194°F (90.0°C) – recycle
- Flue exceeds 204°F (95.6°C) – manual reset hard lockout

4. Flow Switch

The flow switch shuts down the boiler when there is insufficient water flow in the boiler primary loop. When water flow is restored to a boiler-specific minimum value (see Table 6-3), the flow switch detects flow and automatically restarts the boiler. The flow switch is required and is factory provided.

5. Return Temperature Higher Than Supply Temperature (Inversion Limit)

If return water temperature exceeds supply water temperature for longer than a limit time delay, the control shuts down the boiler and delays restart. If the inverted temperature is detected more than five times, the boiler shuts down with a hard lockout. Condition is caused by incorrect supply and return piping connections.

6. Ignition Failure

The control monitors ignition using a burner mounted flame sensor. Response on ignition failure is as follows:

- Size 399: retries five times, then soft lockout for one hour
- Size 500-800: retries one time, then manual reset hard lockout

10 Operation

D. Multiple Boiler Control Sequencer (continued)

7. Automatic Reset Limit Devices

If any below listed limit opens, the boiler shuts down and provides an open limit indication. The boiler will automatically restart once the limit closes. An external limit control with its own manual reset button requires pressing external limit reset button after limit closes even when connected to Auto Reset External Limit terminals.

- Sump pressure switch – opens if inadequate air flow is detected during operation
- Condensate float switch – opens if condensate drain is blocked
- 24V LWCO (if used) – opens if low water condition is detected
- Device(s) connected to Auto Reset External Limit terminals

8. Manual Reset Limit Devices

If any below listed limit opens, the boiler will restart only after the limit closes and the boiler control manual reset button is depressed. During boiler start sequence, air proving switch must prove open before blower starts and closed after blower starts. If air proving switch is not in the required position, the control waits for a preset time period and then shuts down with a manual reset hard lockout.

- Thermal link – opens if rear of combustion chamber overheats; one time use device.
- Burner door thermostat – opens if burner door overheats, manual reset button on thermostat.
- High and low gas pressure switches (if used, size 500-800 only) – open if gas pressure is outside of preset limits, manual reset button on each switch.
- Air proving switch – opens if inadequate air flow is detected prior to ignition.
- Device(s) connected to Man Reset External Limit terminals.

9. Central Heating System Frost Protection

When enabled, Frost Protection starts the boiler and system pump and fires the boiler when low outside air and low supply water temperatures are sensed. The Control provides the following control action when frost protection is enabled:

Table 10-2: Frost Protection

Device Started	Start Temperatures	Stop Temperatures
Boiler Pump	Outside Air < -0°F (-18°C) or Supply Water < 45°F (7.2°C)	Outside Air > -4°F (-16°C) Supply Water > 50°F (10°C)
Boiler	Supply Water < 38°F (3.3°C)	Supply Water > 50°F (10°C)

FROST PROTECTION NOTE

The Control helps provide freeze protection for the boiler water. Boiler flue gas condensate drain is not protected from freezing. Since the Control only controls the system and boiler circulators individual zones are not protected. It is recommended that the boiler be installed in a location that is not exposed to freezing temperatures.

D. Multiple Boiler Control Sequencer

1. “Plug & Play” Multiple Boiler Control Sequencer

When multiple boilers are installed, the Control's Sequencer may be used to coordinate and optimize the operation of up to eight (8) boilers. Boilers are connected into a “network” by simply “plugging in” standard ethernet cables into each boiler's “Boiler-To-Boiler Communication” RJ45 connection.

2. Sequencer Master

A single Control is selected to be the Sequencer Master. The call for heat, outdoor sensor, header sensors, and common pumps are wired to the Sequencer Master “enabled” Control.

3. Lead/Slave Sequencing & Equalized Run Time

One boiler is a “Lead” boiler and the remaining networked boilers are “Slaves”. When demand is increasing, the Lead boiler is the first to start and the Slave boilers are started in sequential order (1,2,3,...) until the demand is satisfied. When demand is decreasing, the boilers are stopped in reverse order with the Lead boiler stopped last (... ,3,2,1). To equalize the run time the sequencer automatically rotates the Lead boiler after 24 hours of run time.

4. Improved Availability

The following features help improve the heat availability:

- Backup Header Sensor: In the event of a header sensor failure the lead boiler's supply sensor is used by the Sequence Master to control firing rate. This feature allows continued coordinated sequencer control even after a header sensor failure.

10 Operation D. Multiple Boiler Control Sequencer *(continued)*

- b. “Stand Alone” Operation Upon Sequence Master Failure: If the Sequence Master Control is powered down or disabled or if communication is lost between boilers, individual boilers may be setup to automatically resume control as a “stand alone” boiler.
- c. Slave Boiler Rate Adjustment: Each slave boiler continues to monitor supply, return and flue gas temperatures and modifies the Sequence Master’s firing rate demand to help avoid individual boiler faults, minimize boiler cycling and provide heat to the building efficiently.
- d. Slave Boiler Status Monitoring: The Sequence Master monitors slave boiler lockout status and automatically skip over disabled boilers when starting a new slave boiler.

5. Customized Sequences

Normally, boilers are started and stopped in numerical order. However, custom sequences may be established to optimize the heat delivery. For example, in order to minimize boiler cycling, a large boiler may be selected to run first during winter months and then selected to run last for the remainder of the year.

6. Multiple Demands

The Sequence Master responds to Central Heat, Auxiliary Heat, DHW, and frost protection demands similar to the stand alone boiler. For example, when selected and DHW priority is active, the sequence master uses DHW setpoint, “Diff Above”, “Diff Below” and pump settings.

7. Shared or Isolated DHW Demand

When the Indirect Water Heater (IWH) parameter is set to “Primary Piped” the Sequence Master sequences all required boilers to satisfy the DHW setpoint (default 180°F (82.2°C)). When “Boiler Piped” is selected only the individual slave boiler, with the wired DHW demand and pump, fires to satisfy the DHW setpoint.

8. DHW Two boiler Start

When the Indirect Water Heater (IWH) parameter is set to “Primary Piped” and the DHW Two Boiler Start parameter is set to “Enabled” two boilers are started without delay in response to a DHW call for heat. This feature allows rapid recovery of large IWH’s and multiple IWH’s.

9. Optimized Boiler Modulation

Boiler firing rate is managed to increase smoothly as boilers are started. For example, when a second boiler is started the initial firing rate is 100%/2 or 50%, when the third boiler is started the firing rate starts at 200%/3 or 66%. After the initial start, the Sequence Master develops a unison firing rate demand based on it’s setpoint and sensed header temperature.

10. Modulating Condensing Boiler Control

During low loads, the Sequence Master limits firing rates to a ‘Base Load Common Rate” to ensure peak modulating condensing boiler operating efficiency. Lower firing rates boost efficiency by helping increase the amount of flue gas water vapor condensation. The Control maintains a “Base Load Common Rate” until the last lag boiler is started. At this point, the “Base Load Common Rate” is released to allow boilers to modulated as required to meet heat load.

11. Advanced Boiler Sequencing

After there is a Call For Heat input, both header water temperature and boiler firing rate percent are used to start and stop the networked boilers. The Control starts and stops boilers when the water temperature is outside the user selected “Diff Above” and “Diff Below” settings. Also, in order to minimize temperature deviations, the Control adjusts the number of boilers running based on the firing rate. This combination allows the boilers to anticipate slow load changes before they disrupt water temperature yet still respond quickly to sudden load changes. These special sequencer features help reduce energy wasting system temperature swings and the resulting unnecessary boiler cycling.

12. Stop All Boilers

All boilers are stopped without delay if the Call for Heat input is removed, or, if the header temperature is higher than 195°F (90.6°C) (field adjustable).

10 Operation E. Boiler Sequence Of Operation (continued)

E. Boiler Sequence of Operation

1. Normal Operation

Table 10-3: Boiler Sequence of Operation

Status Screen Display		Description
i Boiler 1 <input checked="" type="checkbox"/> Supply 140 F Setpoint 140 F Rate 0% ▾ Priority: Standby Status: Standby	Priority: Standby Status: Standby	(burner Off , circulator(s) Off) Boiler is not firing and there is no call for heat, priority equals standby. The boiler is ready to respond to a call for heat.
i Boiler 1 <input checked="" type="checkbox"/> Supply 140 F Setpoint 140 F Rate 0% ▾ Priority: Central Heat Status: Standby	Priority: Central Heat Status: Standby	(burner Off , circulator(s) On) Boiler is not firing. There is a Central Heat call for heat and the Supply temperature is greater than setpoint minus the "Diff Below".
i Boiler 1 <input checked="" type="checkbox"/> Supply 132 F Setpoint 140 F Rate 98% ▾ Priority: Central Heat Status: Prepurge 10	Priority: Central Heat Status: Prepurge	When supply temperature drops, burner demand continues with following Status shown: Safe Startup: Flame circuit is tested. Drive purge: The blower is driven to the fan purge speed. Prepurge: After the blower reaches the fan purge speed setting the 10 second combustion chamber purge is conducted.
i Boiler 1 <input checked="" type="checkbox"/> Supply 132 F Setpoint 140 F Rate 89% ▾ Priority: Central Heat Status: Direct Ignition	Priority: Central Heat Status: Direct ignition	After purge time is complete, the following Status is shown: Drive light-off: The blower is driven to light-off rate. Pre-Ignition Test: After the blower reaches light-off rate a safety relay test is conducted. Pre-ignition: Spark is energized and it is confirmed that no flame is present Direct Ignition: Spark and Main fuel valve are energized.
i Boiler 1 <input checked="" type="checkbox"/> Supply 132 F Setpoint 140 F Rate 100% Priority: Central Heat Status: Running	Priority: Central Heat Status: Running	(burner On , circulator(s) On) After flame is proven, the sequence continues with run stabilization and low fire hold time. Once the field adjustable low fire hold time is completed, normal boiler operation begins, modulation rate depending on temperature and setpoint selections.
i Boiler 1 <input checked="" type="checkbox"/> Supply 132 F Setpoint 180 F Rate 100% Priority: Domestic Hot Water Status: Running	Priority: Domestic Hot Water Status: Running	If the Central Heat call for heat is active and a Domestic Hot Water (DHW) call for heat received the DHW demand becomes the "priority" and the modulation rate, setpoint, "Diff Above" and "Diff Below" are based on DHW settings.
i Boiler 1 <input checked="" type="checkbox"/> Supply 132 F Setpoint 140 F Rate 100% ▾ Priority: Standby Status: Postpurge 30	Priority: Standby Status: Post-purge	(burner Off , circulator(s) Off) If there is no call for heat, the main fuel valve is closed and, the blower is driven to the fan post-purge speed. After the blower reaches the fan post-purge speed setting, the 30-second combustion chamber purge is conducted.
i Boiler 1 <input checked="" type="checkbox"/> Supply 132 F Setpoint 140 F Rate 100% ▾ Priority: Standby Status: Standby delay 30	Priority: Standby Status: Standby Delay	Standby delay status is entered when a delay is needed, before allowing the burner control to be available. For example, when Anti-Short Cycle time is selected, Standby delay is entered after the Central Heat call for heat ends. Select "Help" button from the "Home Screen" to determine the cause of the Standby Delay.
i Boiler 1 <input checked="" type="checkbox"/> Supply 132 F Active Fault Setpoint 140 F Rate 100% ▾ Priority: Standby Status: Lockout	Priority: Standby Status: Lockout	A lockout status is entered to prevent the boiler from running due to a detected problem. Select "Help" button from the "Home Screen" to determine the cause of the Lockout. The last 10 Lockouts are recorded in the Lockout History.

10 Operation

E. Boiler Sequence Of Operation (continued)

2. Using The Display

The Control includes a touch screen LCD display. The user monitors and adjusts boiler operation by selecting screen navigation “buttons” and symbols. The “Home Screen” and menu selections are shown below. When no selection is made, while viewing any screen, the display reverts to the “Home Screen” after 4 minutes. The “Home Screen” provides boiler temperature, firing rate in BTU/hr, boiler status, efficiency information and page links.

Menu Buttons

The Home Screen Menu Buttons connect the displays four main display groups:

Information Symbol

“Information” symbol links most screens to screen content explanations. New terminology used in status and adjustment screens are explained in plain words.

Fault Indication

In the event of a boiler fault the screen color turns red and the user is guided by “blinking” touch buttons to Help screens that explain the problem cause and corrective action.

Rate

Firing rate is displayed as kbtu/hr input.

Demand Status

The reason or cause of the boiler demand is displayed; Central Heat, Auxiliary Heat, Domestic Hot Water, Sequencer Control (peer-to-peer Demand) or Frost Protection. Warm Weather Shutdown status is shown. “Standby” is shown when no demand is present.

Energy Save On Indication

Outdoor Air Reset, DHW or setback have lowered boiler water setpoint.

High Efficiency On Indication

Return temperature is low enough to allow energy saving flue gas condensation.

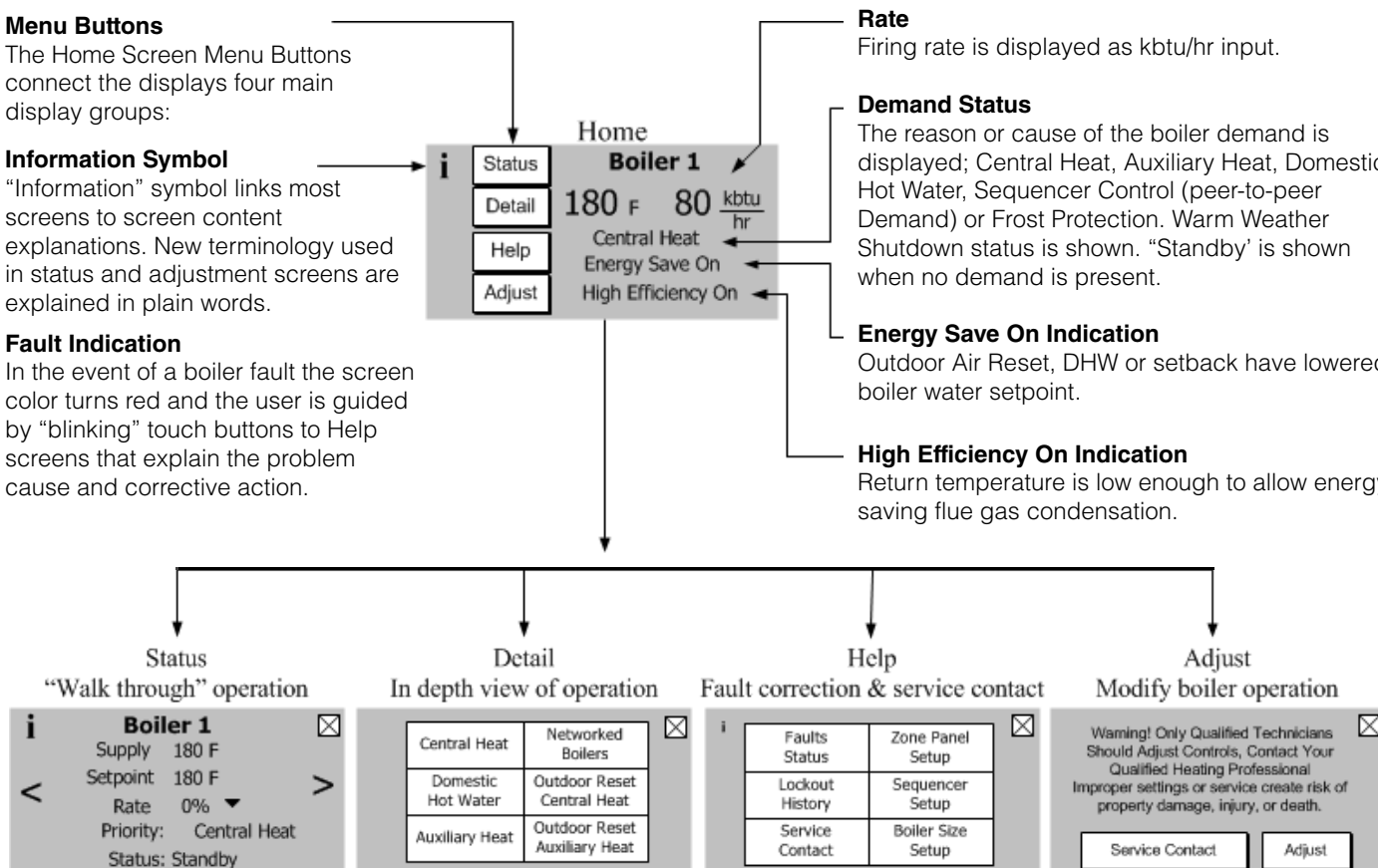

Figure 10-4: Home Screen Details

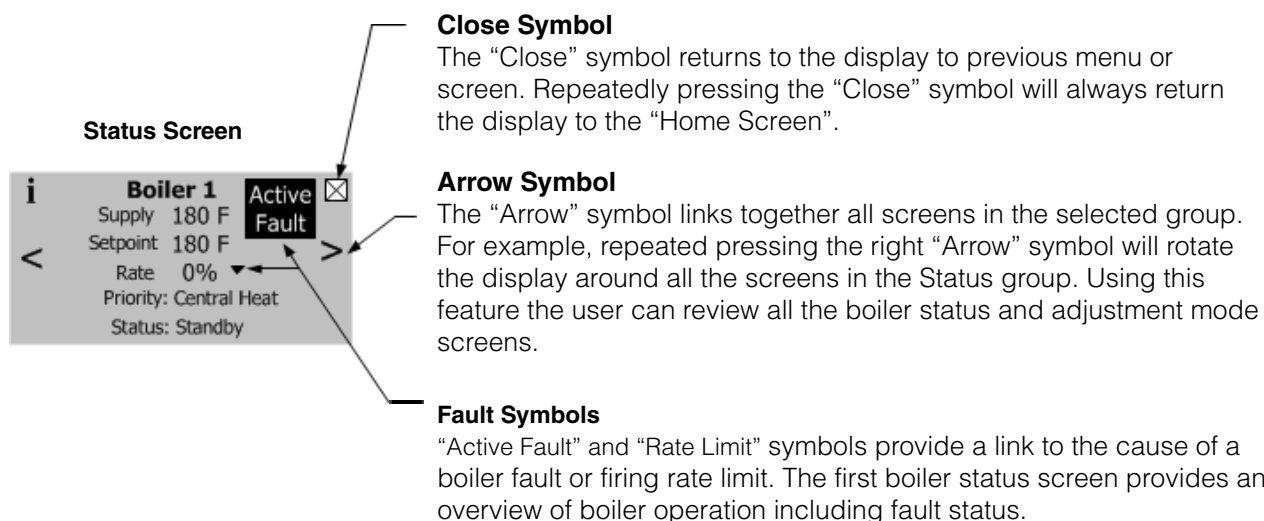

Figure 10-5: Screen Navigation

10 Operation

E. Boiler Sequence Of Operation (continued)

3. Status Screens

Boiler Status screens are the primary boiler monitoring screens. The user may simply scroll through boiler operation by repeatedly selecting the right or left “arrow” symbol. These screens are accessed by selected the “Status” button from the “Home Screen”.

NOTE

Zone control status is only visible if Zone Panel is connected. Zone Panel 1 and 2 shown typical for 1 through 4.

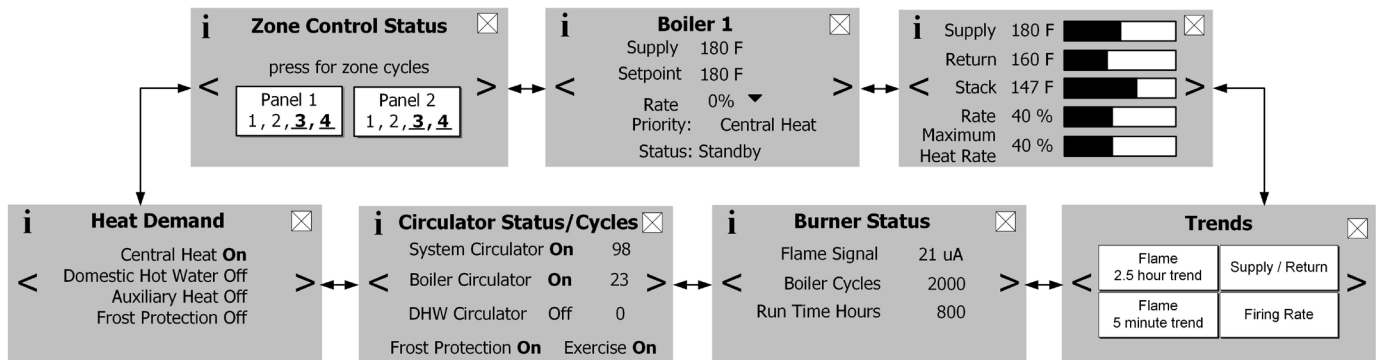

Figure 10-6: Status Screen Overview

Supply:

Measured supply water temperature. This is the temperature being used to start/stop and fire boiler when there is a call-for-heat. Header temperature is shown when selected.

Setpoint:

This is the active setpoint. This temperature setpoint determined based on active priority; Central Heat, Auxiliary Heat or Domestic Hot Water. The setpoint may be the result of Outdoor Air Reset and Setback selections.

Rate:

The rate % value is equal to the actual kbtu/hr input divided by the boiler rated input.

Priority:

The selected Priority is shown. Available Priorities are: Standby (no call for heat is present), Sequencer Control, Central Heat, Auxiliary Heat, Domestic Hot Water, Frost Protection or Warm Weather Shutdown.

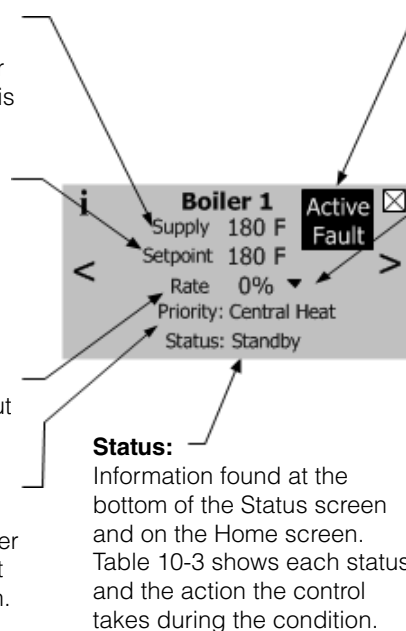

Active fault:

A hard lockout will cause the active fault indication to appear. When visible the text becomes a screen link to the “Help” Menu.

Rate Limit:

The “▼” symbol appears to the right of the Rate % when firing rate is limited or overridden in any way. During the start-up and shutdown sequence it is normal for the rate to be overridden by the purge, light-off and low fire hold requirements. When a rate limit is the result of boiler protection logic the “▼” symbol blinks and becomes a screen link.

Figure 10-7: Boiler Status Screen Definitions

10 Operation

E. Boiler Sequence Of Operation (continued)

3. Status Screens (continued)

Bargraph Screen

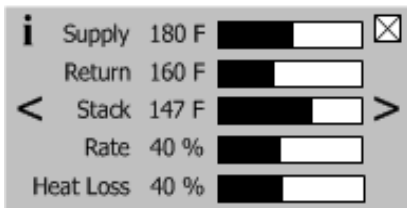

Bargraph Screen

The bargraph screen presents measured values for easy comparison. Included on this screen is firing rate and when the Zone Panel is connected the measure Heat Loss. Measured heat loss is the heat rate kbtu/hr sum of all active (call for heat) zones. This value represents the maximum required firing rate.

Trend Screens

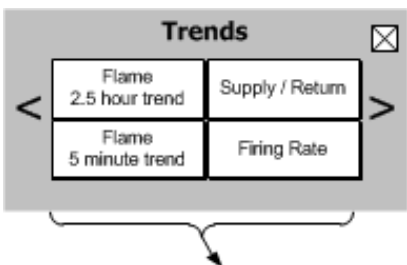

Data Logging

Real time graphic trends allow users to observe process changes over time providing valuable diagnostic information. For example, flame current performance over start up periods and varying loads can be an indication of gas supply issues. Additionally, supply and return temperature dual pen trends brings a focused look at heat exchanger and pump performance. For example, studying a differential temperature trend may indicate pump speed settings need to be changed.

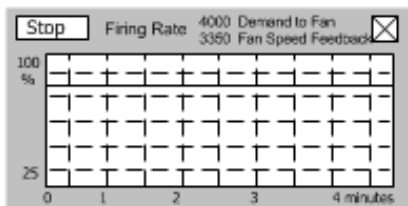
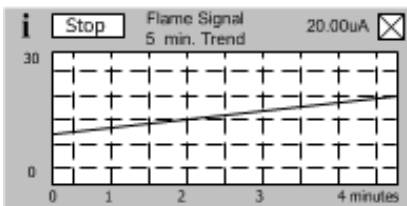
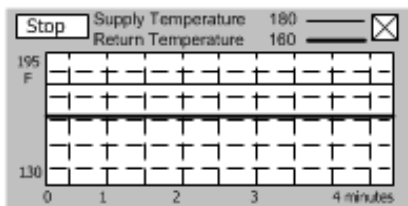
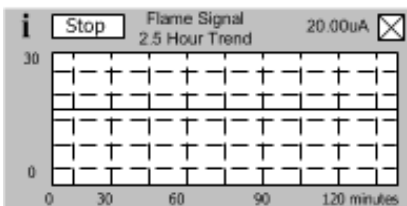

NOTE:

Firing Rate Trend shows fan demand and feedback.

Burner Status Screen

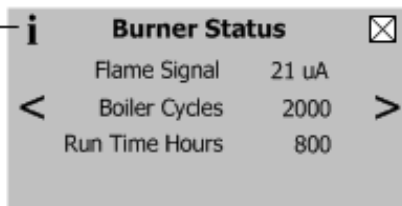
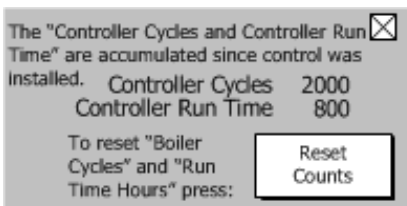

Cycles and Hours

Boiler cycles and hours are used to monitor the boilers overall compatibility to the heating load. Excessive cycling compared to run time house may be an indication of pumping, boiler sizing or adjustment issues.

NOTE:

"Boiler Cycle" and "Run Time Hours" are resetable by selecting the "Reset Counts" button located on the information screen. The "Controller Cycles" and "Controller Run Time" data is not resetable and remains for the life of the control.

10 Operation

E. Boiler Sequence Of Operation (continued)

Circulator Status Screen

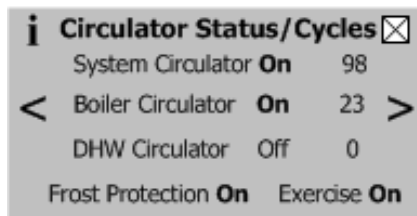

Pumping is a major part of any hydronic system. This screen provides the status of the boiler's demand to connected pumps as well as the status of Frost Protection and pump Exercise functions.

Head Demand Screen

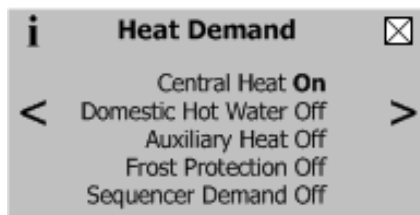

This screen provides the status of the boiler's five (5) possible heat demands. When demand is off the Control has not detected the call-for-heat. This screen allows the user to determine which demands are present when more than one demand is present.

Zone Control Status Screens

NOTE:

Only visible if Zone Panel is connected. Zone Panel 1 and 2 shown typical for 1 through 4.

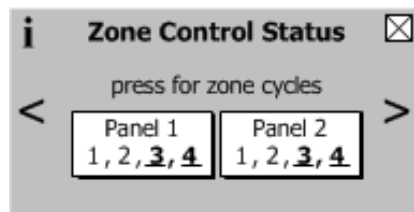

Zone Control Status

Screen provides status and a page links for up to four zone panels. Individual zone "on" status is shown by a bold zone number with a solid underscore. "Press" the zone control "button" to view individual zone .

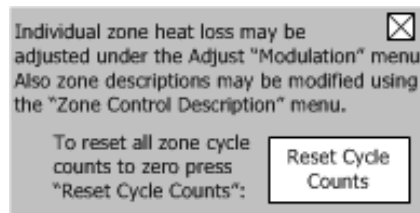

NOTE:

Zone cycles are resettable by selecting the "Reset Cycle Counts" button located on the information screen.

i **Zone Panel 1**

Demand	Cycles	Size(kbtu/hr)
KITCHEN	OFF 500	15
KIDS BEDROOM	OFF 100	23
MASTER BEDROOM	ON 50	28
Domestic HW	ON 3500	40

Zone Panel 1 (typical for 2 through 4)

Zone panel screens show individual zone status, cycle counts and individual zone heat loss size in kbtu/hr. Individual zone heat loss may be adjusted under the Adjust "Modulation" menu. Also zone descriptions may be modified using the "Zone Control Description Setup" menu.

4. Detail Screens

Detail screens are accessed by selecting the "Detail" button from the "Home Screen". These screens provide in depth operating parameter status such as "On Point", "Off Point" and "Setpoint Source" information. Demand-specific details are provided for Central Heat, Auxiliary Heat, Domestic Hot Water and the Sequence Master demands. Detail screens also provide details on outdoor air reset and Sequencer network status. Sequencer screens are only shown when the Sequence Master is enabled and, Auxiliary Heat screen is only shown when a Zone Panel is connected.

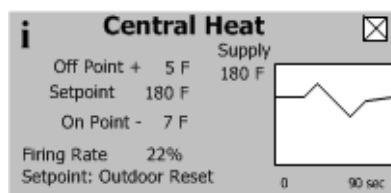

Demand Detail Display

(Central Heat shown, Typical for Auxiliary Heat, Domestic Hot Water and Sequencer Master)

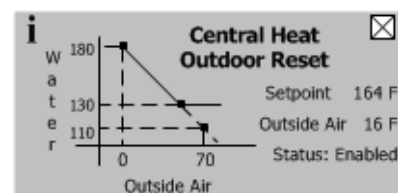

Outdoor Reset Display

(Central Heat shown, Typical for Auxiliary Heat)

10 Operation

E. Boiler Sequence Of Operation *(continued)*

5. Multiple Boiler Sequencer Screens

When the Sequence Master is enabled the following screens are available:

The Sequencer Status screen is selected by “pressing” “Status” button from the “Home Screen” when Sequence Master is enabled.

Header:

Measured header water temperature. This is the temperature being used to start, stop and fire boiler when there is a call-for-heat.

Setpoint:

This is the active setpoint. This temperature is the result of Outdoor Air Reset, Setback and Domestic Hot Water (DHW) selections.

Networked Boiler Status:

Provides connected, start sequence and firing rate status information for all connected boiler addresses. The boiler number is underlined if the boiler is running, and blinks if the boiler has the start sequence in progress. For example the status for boiler address 1 is provided as follows:

- 1 - Boiler 1 is connected to the network
- 1 - “Blinking underline” - boiler 1 is starting
- 1 - “Solid underline” - boiler 1 is running

Rate:
The rate % value is equal to the Sequence Master demand to the individual boiler. Actual boiler firing rate is found on the individual boiler status pages.

Priority:
The selected Sequencer Priority is shown. Available Priorities are: Standby (no call for heat is present), Central Heat, Auxiliary Heat, Domestic Hot Water, Frost Protection or Warm Weather Shutdown.

The “Networked Boilers” screen is selected by “pressing” the “Detail” button from the “Home Screen” and “pressing” Networked Boilers” from the “Detail” screen.

Boiler Number:

Up to eight (8) boiler’s status is shown.

Lead Boiler:

Upon power up the lowest numbered boiler becomes the lead boiler. The lead boiler is the first to start and last to stop. The lead boiler is automatically rotated after 24 hours of run time.

Additionally, the lead is rotated if there is a lead boiler fault.

Boiler	Lead	Firing Rate	Firing
Boiler 1	Lead	50%	Firing
Boiler 2		50%	Firing
Boiler 3		0%	Available
Boiler 4		0%	Available

Firing Rate:
Demanded firing rate is provided.

Sequence Status:

Slave boiler status is provide as follows:

- Available:** Boiler is ready and waiting to be started by the Sequencer Master.
- Add Stage:** Boiler has begun the start sequence but has not yet reached the boiler running status.
- Running:** Boiler is running.
- On Leave:** Boiler has left the network to service a DHW demand.
- Recovering:** Boiler is in the process of returning to the network. For example, the slave boiler is in the Postpurge state.
Note: The recovery time is normally 30 seconds. However, if the slave boiler fails to start the recovery time increases from 30 seconds to 5, 10 and 15 minutes.
- Disabled:** Boiler has a lockout condition and is unable to become available to the Sequencer Master.

10 Operation

F. Changing Adjustable Parameters *(continued)*

F. Changing Adjustable Parameters

1. Entering Adjust Mode

The Control is factory programmed to include basic modulating boiler functionality. These settings are password protected to discourage unauthorized or accidental changes to settings. User login is required to view or adjust these settings:

- Press the “Adjust” button on the “Home Screen”.
- Press the “Adjust” button on the Adjust Mode screen or Press “Service Contact” for service provider contact information.
- Press “Login” button to access password screen.
- Press 5-digit display to open a keypad. Enter the password (Installer Password is 86) and press the return arrow to close the keypad. Press the “Save” button.
- Press the “Adjust” button to enter Adjustment mode.

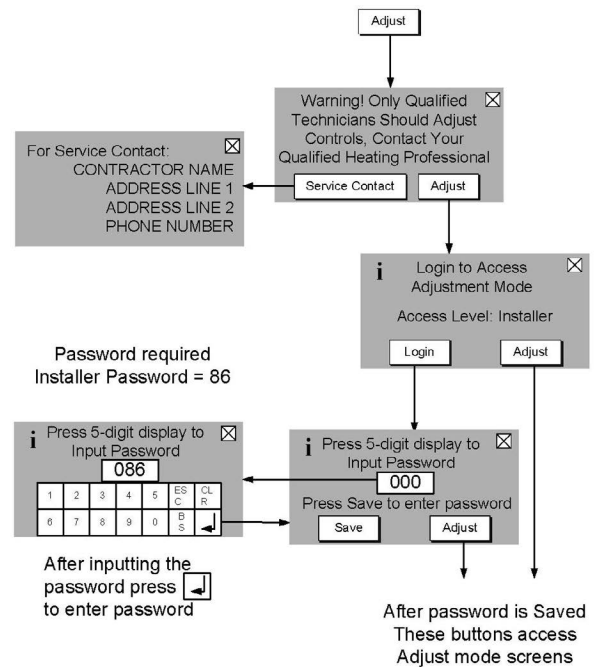
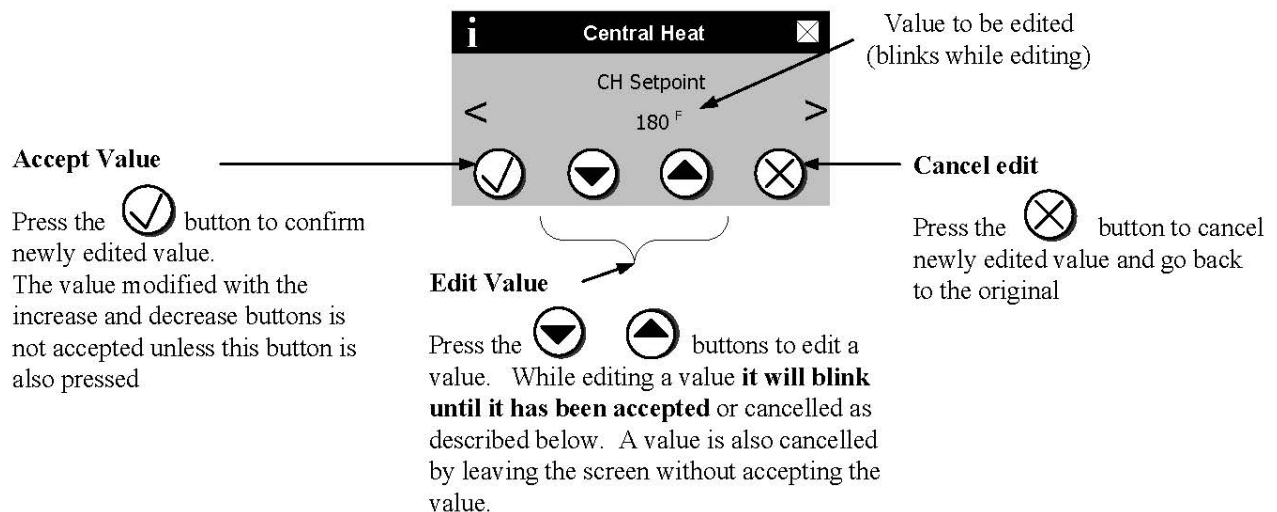

Figure 10-8: Adjust Mode Screens

2. Adjusting Parameters

Editing parameters is accomplished as follows:



10 Operation

F. Changing Adjustable Parameters *(continued)*

2. Adjusting Parameters *(continued)*

The following pages describe the Control's adjustable parameters. Parameters are presented in the order they appear on the Control's Display, from top to bottom and, left to right. From the "Home Screen" select the Adjust button to access the adjustment mode screens show below (if required, refer to "1. Entering Adjust Mode").

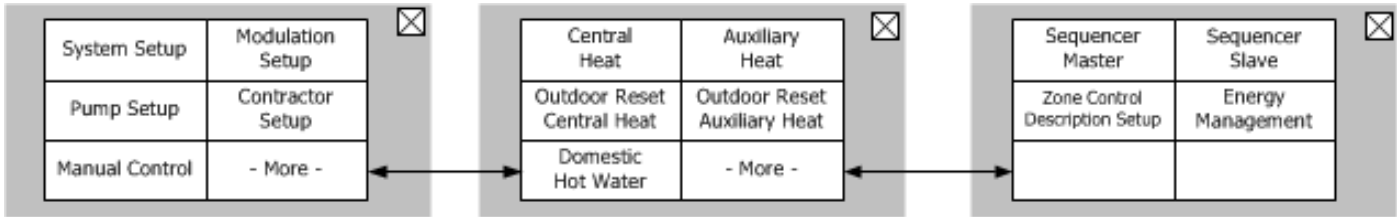

"Press" System Setup button to access the following parameters:

Factory Setting	Range / Choices	Parameter and Description												
Fahrenheit	Fahrenheit, Celsius	Temperature Units The Temperature Units parameter determines whether the temperature is represented in units of Fahrenheit or Celsius degrees.												
4	0-14	Display Brightness Display brightness is adjustable from 0 to 14.												
8	0-14	Display Contrast Display contrast is adjustable from 0 to 14.												
Wired	Not Installed, Wired, Wireless	Outdoor Sensor Source Not Installed Outdoor Sensor is not connected to the boiler, the sensor is not monitored for faults. Wired Outdoor Sensor is installed and wired to boiler low voltage PCB. Wireless Outdoor sensor is installed and wireless.												
0	-50 to +50°F tenths of degree (-45.6 to 10°C)	Outdoor Air Sensor Calibration Outdoor Air Sensor Calibration offset allows a single point calibration. Using a reliable source (reference) for outdoor temperature measure outdoor air temperature. Set the offset equal to the difference between the controller reading and the reference. The result will be the Control's measurement matching the reference reading.												
Not Connected	Connected, Not Connected	Zone Control Status Connected When the Zone Control is connected adjustable settings are automatically shown under the Adjust "Modulation", "Auxiliary Heat" and "Zone Control Description Setup" menus. This feature allows these adjustments to be made before the zone panel is connected. When the user selects "Show As If Connected" Zone Control related parameters are made visible and may be adjusted.												
Enabled	Enable/Disable	Frost Protection Disable Frost Protection is not used. Enable Boiler circulator starts and boiler fires when low outside air, supply and return temperatures are sensed as follows: <table border="1" style="margin-left: auto; margin-right: auto;"> <thead> <tr> <th>Device Started</th> <th>Start Temperatures</th> <th>Stop Temperatures</th> </tr> </thead> <tbody> <tr> <td>Boiler</td> <td>Outside Air < -0°F (-18°C)</td> <td>Outside Air > -4°F (-16°C)</td> </tr> <tr> <td>Pump</td> <td>or Supply Water < 45°F (7.2°C)</td> <td>Supply Water > 50°F (10°C)</td> </tr> <tr> <td>Boiler</td> <td>Supply Water < 38°F (3.3°C)</td> <td>Supply Water > 50°F (10°C)</td> </tr> </tbody> </table>	Device Started	Start Temperatures	Stop Temperatures	Boiler	Outside Air < -0°F (-18°C)	Outside Air > -4°F (-16°C)	Pump	or Supply Water < 45°F (7.2°C)	Supply Water > 50°F (10°C)	Boiler	Supply Water < 38°F (3.3°C)	Supply Water > 50°F (10°C)
Device Started	Start Temperatures	Stop Temperatures												
Boiler	Outside Air < -0°F (-18°C)	Outside Air > -4°F (-16°C)												
Pump	or Supply Water < 45°F (7.2°C)	Supply Water > 50°F (10°C)												
Boiler	Supply Water < 38°F (3.3°C)	Supply Water > 50°F (10°C)												
0 min.	0-20 min.	Anti-Short Cycle Time Anti-short cycle is a tool that helps prevent excessive cycling resulting from a fast cycling Thermostat or Zone valves. It provides a minimum delay time before the next burner cycle. DHW demand is serviced immediately, without any delay.												
Disabled	Enable/Disable	Warm Weather Shutdown Enable Disable Warm Weather Shutdown (WWSD) is not used. Enable The boiler and pumps will not be allowed to start in response to a central heat call for heat if the outside temperature is greater than the WWSD setpoint. WWSD is initiated as soon as outside air temperature is above WWSD Setpoint. The Control does not require call for heat to be satisfied. The boiler will still start in response to a Domestic Hot Water call for heat.												
70°F (21.1°C)	20 to 100°F (-6.7 to 37.8°C)	Warm Weather Shutdown Setpoint The Warm Weather Shutdown (WWSD) Setpoint used to shutdown the boiler when enabled by the "WWSD Enable" parameter.												

10 Operation

F. Changing Adjustable Parameters *(continued)*

⚠ WARNING

Asphyxiation Hazard. Boiler type is factory set and must match the boiler model. Only change the boiler type setting if you are installing a new or replacement Control. The boiler type setting determines minimum and maximum blower speeds. Incorrect boiler type can cause hazardous burner conditions and improper operation that may result in PROPERTY LOSS, PHYSICAL INJURY OR DEATH.

“Press” Modulation Setup button to access the following parameters:

Factory Setting	Range / Choices	Parameter and Description
Varies by Model	See Figure 10-9.	<p>Boiler Type Boiler Size Setup To verify the boiler size selection, a qualified technician should do the following:</p> <ol style="list-style-type: none"> 1. Check boiler’s label for actual boiler size. 2. Set “Boiler Type” to match actual boiler size. 3. Select “Confirm”. <p>The Boiler Type parameter changes the minimum and maximum modulation settings. This parameter is intended to allow a user to set the parameters for altitudes above 2,000 ft. or in a spare part control to a particular boiler model. See Figure 10-9.</p>

NOTICE: If boiler is being installed at elevation above 2,000 ft., refer to Appendix A: Instructions for High Altitude Installations Above 2,000 ft.

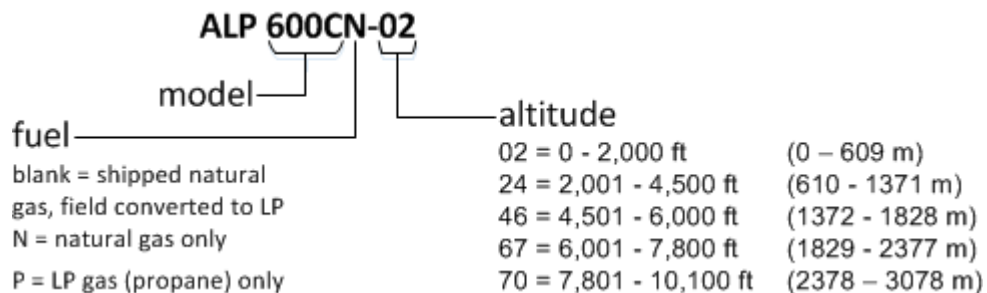

Figure 10-9: Boiler Model (Boiler Type) Decoding

10 Operation F. Changing Adjustable Parameters (continued)

Expected Heat Rate Adjustment Screens (Heat Match Software)

The Control is shipped with defaults that will provide improved operation. Adjustment is only required to optimize setup.

The expected heat rate adjustment is used to better match boiler output to the home heating needs. After receiving a call for heat the Control first uses the expected heat rate value to set a maximum heat rate. The maximum heat rate is the highest heat rate that the boiler can fire to at that moment. The maximum heat rate is the summation of the expected heat rates for the active (turned on) zones. After establishing the maximum heat rate, the Control then measures water temperature and fires the boiler only as hard as required for the heat demand.

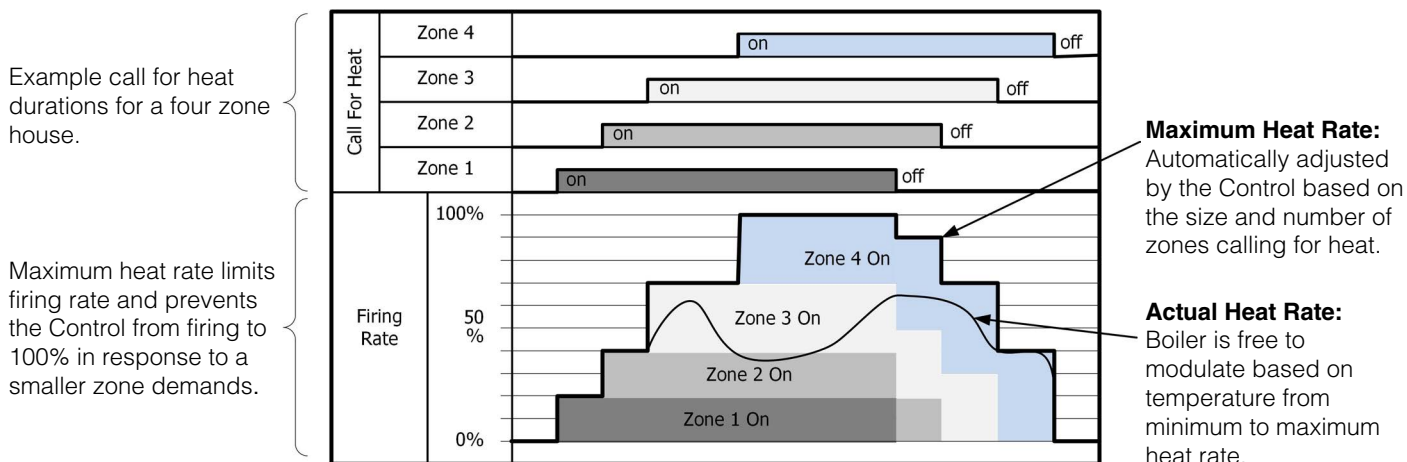
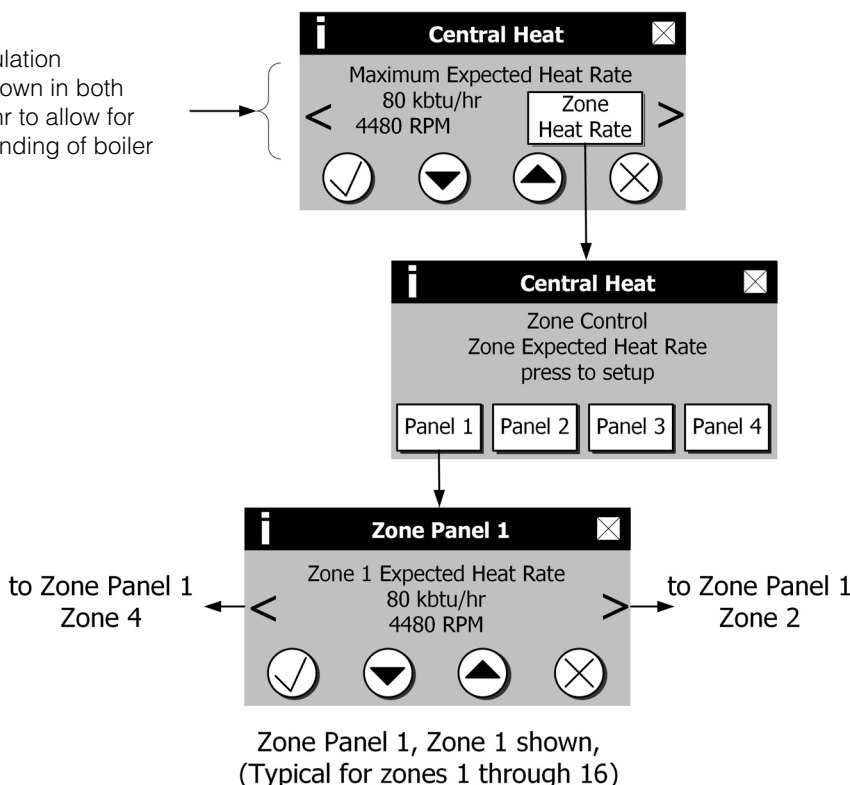

Figure 10-10: Four Zone House (with Zone Control Connected)

Maximum modulation numbers are shown in both RPM and kbtu/hr to allow for easier understanding of boiler heat rate.



NOTE:

This feature requires Zone Control to be connected. Refer to Electrical section for Zone Control connection information.

The sum of Zone Expected Heat Rates plus DHW Maximum Expected Heat Rate (if DHW is active) is used to calculate the active maximum modulation rate.

Figure 10-11: Expected Heat Rate Adjustment (with Zone Control Connected)

10 Operation

F. Changing Adjustable Parameters *(continued)*

“Press” Modulation Setup button to access the following parameters:

Factory Setting	Range / Choices	Parameter and Description
100%	Minimum to Maximum Heat Rate	Central Heat Maximum Expected Heat Rate This parameter defines the highest modulation rate the Control will go to during a central heat call for heat. If the rated input of the installed home radiation is less than the maximum output of the boiler, change the Central Heat Maximum Expected Heat Rate (fan speed) setting to limit the boiler output accordingly.
80% of CH Maximum Heat Rate	Minimum to Maximum Heat Rate	Domestic Hot Water (DHW) Maximum Expected Heat Rate This parameter defines the highest modulation rate the Control will go to during a Domestic Hot Water call for heat. If the rated input of the indirect water heater is less than the maximum output of the boiler, change the DHW Maximum Expected Heat Rate (fan speed) setting to limit the boiler output accordingly.
100%	Minimum to Maximum Heat Rate	Auxiliary Maximum Expected Heat Rate This parameter defines the highest modulation rate the Control will go to during the auxiliary heat call for heat. If the rated input of the Auxiliary Heat Zones is less than the maximum output of the boiler, change the Auxiliary Heat Maximum Expected Heat Rate (fan speed) setting to limit the boiler output accordingly.
40%	Minimum to Maximum Heat Rate	Zone 1 Expected Heat Rate (typical for zone 1 through 16) This parameter defines the highest modulation rate the Control will go to during the Zone 1 call for heat. If the rated input of the installed home radiation in zone 1 is less than the maximum output of the boiler, change the Zone 1 Expected Heat Rate (fan speed) setting to limit the boiler output accordingly.
15 Minutes	0 to 60 Minutes	Zone Release Time After the Zone Release Time, if a zone has not been satisfied (thermostat opens) the measured heat loss will be released to increase to the Central Heat Maximum Heat Rate.
Varies by Model	Varies by Model	Minimum Heat Rate This parameter is the lowest modulation rate the Control will go to during any call for heat.
Varies by Model	399: 3,500 - 4,000 rpm 500 - 800: non-adjustable	Lightoff Heat Rate This is the blower speed during ignition and flame stabilization periods.

10 Operation

F. Changing Adjustable Parameters *(continued)*

“Press” Pump Setup button to access the following parameters:

Factory Setting	Range / Choices	Parameter and Description	
Any Demand	Never Any Demand Central Heat No Priority Central Heat Optional Priority	System Pump run pump for: Activates the system pump output according to selected function. Never: Any Demand: Central Heat No Priority: Central Heat Optional Priority:	Pump is disabled and not shown on status screen. Pump runs during any call for heat. Pump runs during central heat and frost protection call for heat. Pump <u>does not start</u> for a DHW call for heat and continues to run during Domestic Hot Water Priority. Pump runs during central heat and frost protection call for heat. Pump <u>does not start</u> for a DHW call for heat and will be forced off if there is a DHW call for heat and Domestic Hot Water Priority is active.
Any Demand	Any Demand Central Heat Off DHW Demand Header Sensor Demand/ Combustion Air Damper	Boiler Pump run pump for: Activates the boiler pump and combustion air damper (if using room air) output according to selected function. Any Demand: Central Heat Off DHW Demand: Header Sensor Demand/ Combustion Air Damper:	Pump runs /damper opens during any call for heat. Make sure indirect water heater and DHW circulator are sized to maintain flow through boiler within limits shown in Table 6-3. Pump runs during central heat and frost protection call for heat. Pump does not start for a DHW call for heat and will be forced off if there is a DHW call for heat and Domestic Hot Water Priority is active. Pump runs when boiler is <u>firing</u> to satisfy any call for heat. Used when header sensor is enabled to prevent unnecessary operation of boiler pump. Also used when combustion air damper is wired to Boiler Pump output. NOTE: Header Sensor must be used when combustion air damper output is required.
Primary Loop Pipe IWH	Never Primary Loop Piped IWH Boiler Piped IWH Fresh Air Damper	Domestic Pump run pump for: Activates the Domestic pump output according to selected function. Never: Primary Loop Piped IWH: Boiler Piped IWH:	Pump is disabled and not shown on status screen. Pump runs during domestic hot water call for heat. Domestic Hot Water Priority enable/disable does not affect pump operation. Make sure indirect water heater and DHW circulator are sized to maintain flow through boiler within limits shown in Table 6-3. Pump runs during domestic hot water call for heat. Pump is forced off during a central heat call for heat when Domestic Hot Water Priority “disabled” is selected and when Domestic Hot Water Priority “enable” has been selected and the DHW call for heat has remained on for longer than 1 hour (priority protection time).

10 Operation F. Changing Adjustable Parameters (continued)

Example Pump Parameter selections (continued):

Single Boiler Primary Piped Indirect Water Heater, Optional DHW Priority.

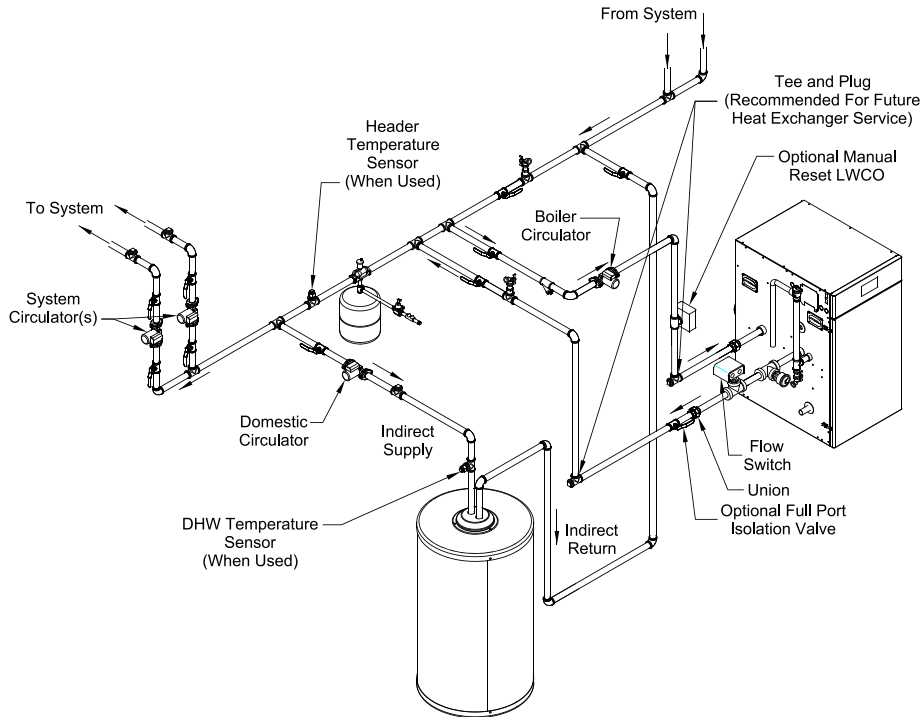

Parameter Selections:

System Pump= "Central Heat ,
Optional Priority"

Boiler Pump = "any demand"

DHW Pump = "Primary Loop Piped IWH"

DHW Priority Enable is optional

Explanation:

This piping arrangement permits the system pump to run or not run when there is a domestic hot water call for heat. Domestic hot water priority is optional. It is permissible for the domestic and system pumps to run at the same time. The boiler pump must run for every call for heat.

Single Boiler with no Indirect Water Heater

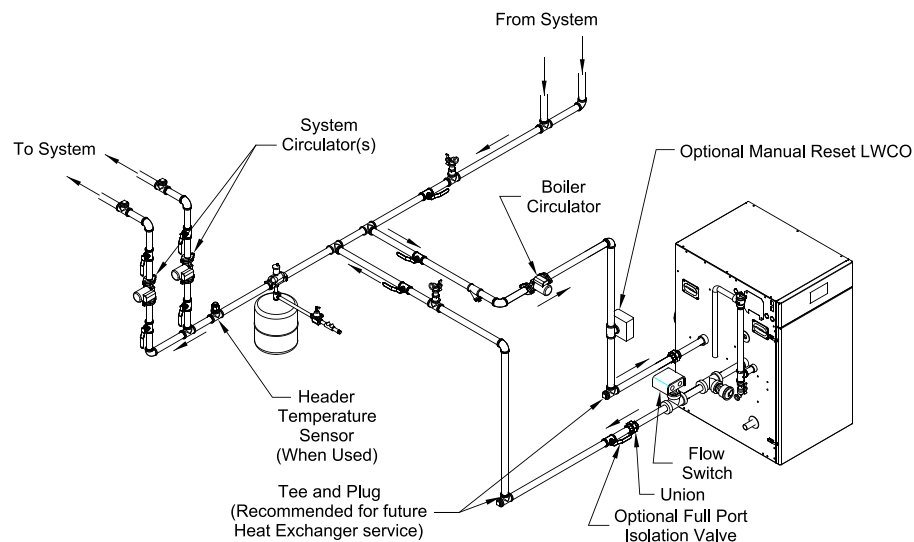

Parameter Selections:

System Pump= "any demand"

Boiler Pump = "any demand"

DHW Pump = "never"

Explanation:

This piping arrangement only services central heat. When there is any demand both boiler and system pumps turn on.

10 Operation

F. Changing Adjustable Parameters (continued)

Example Pump Parameter selections (continued):

Multiple Boilers, Boiler Piped Indirect Water Heater

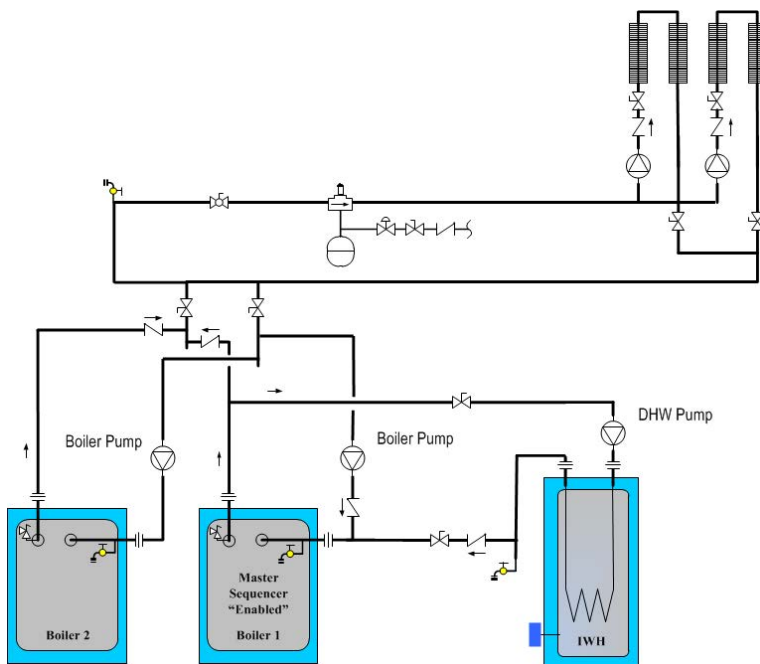

	Sequencer Master (Boiler 1)	Boiler 2
Wiring locations:		
Enable/Disable	X	
DHW Demand	X	
System Pump	X	
DHW Pump	X	
Boiler Pump	X	X
Sequencer Master Parameter Selections:		
Sequencer Master	Enabled	
Indirect Water Heater	"Boiler Piped"	
Pump Parameter Selections:		
System Pump =	Central Heat, No Priority	Never
Boiler Pump =	Central Heat, Off DHW Priority	Any demand
DHW Pump =	Boiler Piped IWH	Never

Explanation:

Make sure indirect water heater and DHW pump are sized to maintain flow through boiler within limits shown in Table 6-3.

This piping arrangement does not allow both the Slave 1's boiler and domestic hot water pump to run at the same time.

When call for Domestic Hot Water is received the DHW pump is turned on and the boiler pump is turned off. However, the system pumps may run to satisfy a central heat demand that is being satisfied by a different slave. The central heat demand is ignored by Slave 1 until the domestic hot water demand is ended. If domestic hot water priority is enabled and priority protection time is exceeded the domestic hot water pump turns off to allow the boiler pump to run.

10 Operation

F. Changing Adjustable Parameters (continued)

Example Pump Parameter selections (continued):

Multiple Boilers, Primary Piped Indirect Water Heater, Optional DHW Priority

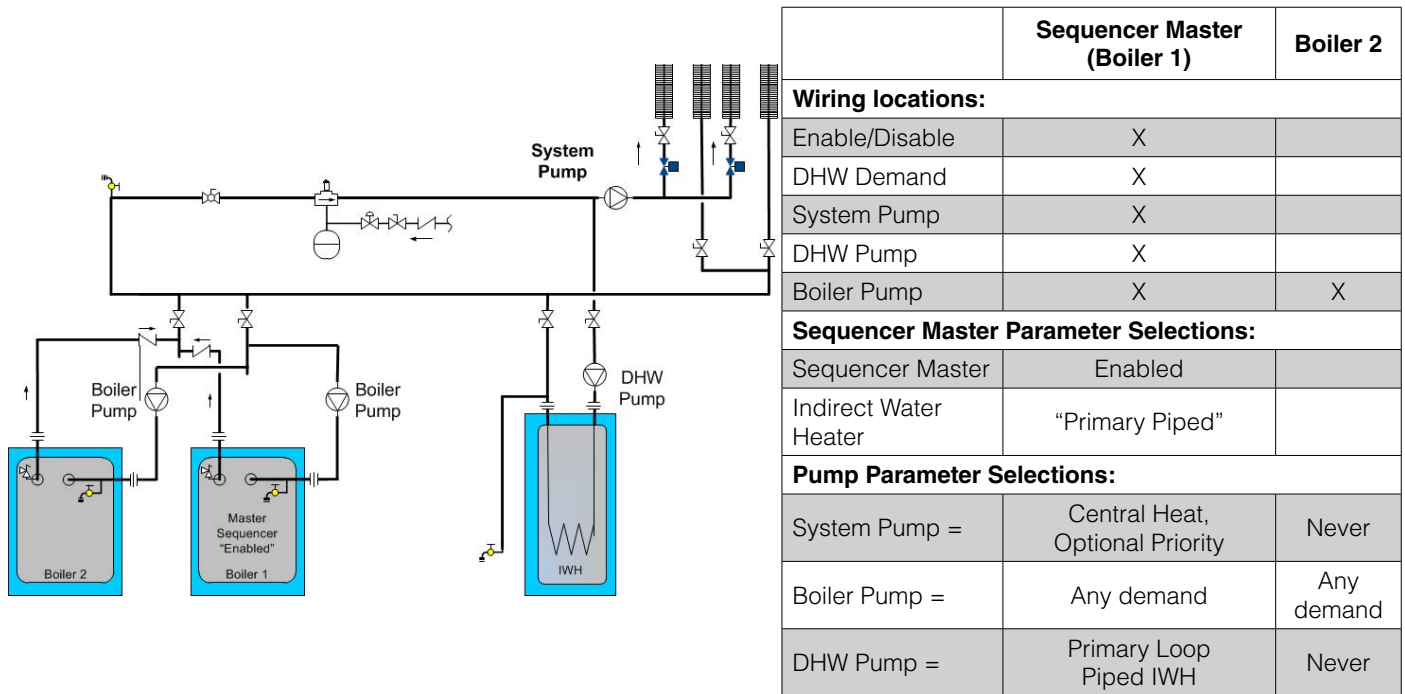

Explanation:

This piping arrangement permits the system pump to run or not run when there is a domestic hot water call for heat. Domestic hot water priority is optional. It is permissible for the domestic and system pumps to run at the same time. The boiler pump must run for every call for heat.

Multiple Boilers, Primary Piped Indirect Water Heater, System Pump Run for Any Demand

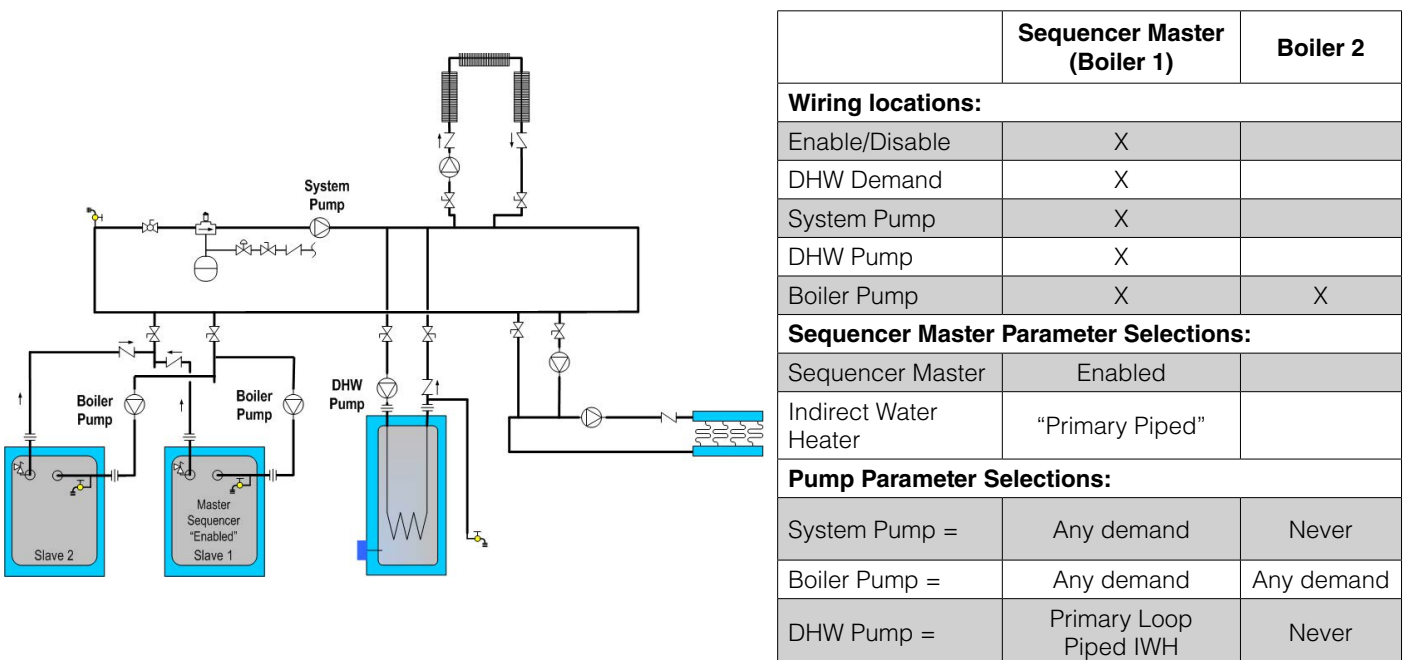

Explanation:

This piping arrangement requires the system pump to be running for any calls for heat. Also the boiler pump must run for any call for heat.

10 Operation F. Changing Adjustable Parameters *(continued)*

“Press” Contractor Setup button to access the following parameters:

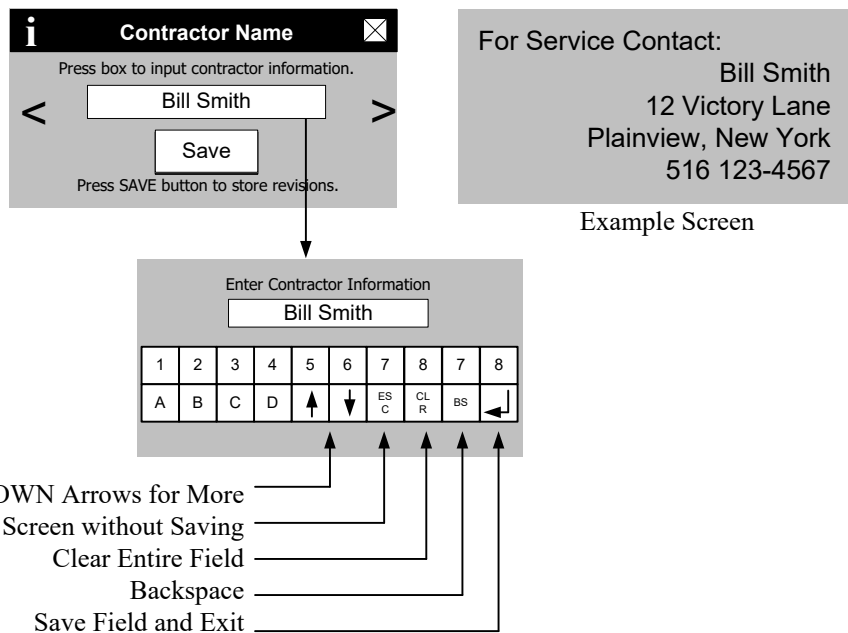

Factory Setting	Range / Choices	Parameter and Description
Contractor Name	User defined	Contractor Name
Address Line 1	User defined	Contractor Address Line 1
Address Line 2	User defined	Contractor Address Line 2
Phone	User defined	Contractor Phone

“Press” Manual Control button to access the following screen:

The Manual Speed Control screen allows the technician to set firing rate at low or high speed for combustion testing.

NOTE:
 Rate % can only be set when the boiler has heat demand and is released to modulate.

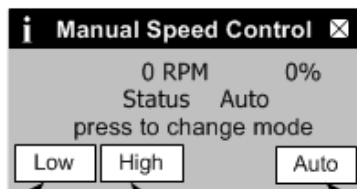

NOTE:
 Selecting “Low” or “High” locks (manual mode) firing rate at min or max Rate %. After combustion testing select “Auto” to return the boiler to normal operation.

“Press” “Low” to select manual firing rate control and Minimum firing rate %

“Press” “High” to select manual firing rate control and Central Heat Maximum firing rate %

Press “Auto” to return firing rate to Automatic Mode

10 Operation

F. Changing Adjustable Parameters *(continued)*

“Press” Central Heat button to access the following parameters:

Factory Setting	Range / Choices	Parameter and Description
180°F (82.2°C)	50°F to 190°F (10°C to 87.8°C)	Central Heat Setpoint Target temperature for the central heat priority. Value also used by the outdoor air reset function.
170°F (76.7°C)	50°F to 190°F (10°C to 87.8°C)	Central Heat Thermostat “Sleep” or “Away” Setback Setpoint Thermostat setback setpoint is used when the EnviraCOM thermostat is in “leave” or “sleep” modes and sensed at E-COM terminals D, R, and C. When setback is “on” the thermostat setback setpoint shifts the reset curve to save energy while home is in a reduced room temperature mode. The reset curve is shifted by the difference between the High Boiler Water Temperature and the Thermostat Setback Setpoint. Honeywell VisionPro IAQ part number TH9421C1004 is a “setback” EnviraCOM enabled thermostat. When connected, it allows boiler water setback cost savings.
10°F (-12.2°C)	2°F to 25°F (-16.7°C to 3.9°C)	Central Heat Diff Above The boiler stops when the water temperature rises ‘Diff Above’ degrees above the setpoint.
5°F (-15.0°C)	2°F to 25°F (-16.7°C to 3.9°C)	Central Heat Diff Below The boiler starts when the water temperature drops ‘Diff Below’ degrees below the setpoint.
3	1 to 5	Response Speed This parameter adjusts the Central Heat temperature controller Proportion Integral Derivative (PID) values. Higher values cause a larger firing rate change for each degree of temperature change. If set too high, firing rate “overshoots” required value, increases to high fire causing the temperature to exceed the “Diff Above” setpoint and cycle the boiler unnecessarily. Lower values cause a smaller firing rate change for each degree of temperature change. If set too low, the firing rate response will be sluggish and temperature will wander away from setpoint.
120 seconds	0 to 1800 seconds	Low Fire Hold Time “Low Fire Hold Time” is the number of seconds the control will wait at low fire modulation rate before being released to modulate. After ignition and flame stabilization periods the firing rate is held at low fire for “Low Fire Hold Time”. This delay allows heat to travel out to the system and provide system feedback prior to the control modulating firing rate.
Supply Sensor	Supply Sensor, Header Sensor	Modulation Sensor Heat Demand may respond to the boiler’s Supply Temperature or Header Temperature sensors. When Header Sensor is selected the boiler is fired in response to the sensor wired to Header Sensor terminals. NOTE: When Header Sensor is selected, also set Boiler Pump parameter to Header Sensor Demand/Combustion Air Damper.

10 Operation

F. Changing Adjustable Parameters *(continued)*

“Press” Auxiliary Heat button to access the following parameters:

Factory Setting	Range / Choices	Parameter and Description
180°F (82.2°C)	60°F to 190°F (15.6°C to 87.8°C)	Auxiliary Heat Setpoint Target temperature for the Auxiliary Heat priority. Value also used by the outdoor air reset function.
170°F (76.7°C)	80°F to 190°F (26.7°C to 87.8°C)	Auxiliary Heat Thermostat “Sleep” or “Away” Setback Setpoint Thermostat setback setpoint is used when the EnviraCOM thermostat is in “leave” or “sleep” modes and sensed at E-COM terminals D, R, and C. When setback is “on” the thermostat setback setpoint shifts the reset curve to save energy while home is in a reduced room temperature mode. The reset curve is shifted by the difference between the High Boiler Water Temperature and the Thermostat Setback Setpoint. Honeywell VisionPro IAQ part number TH9421C1004 is a “setback” EnviraCOM enabled thermostat. When connected, it allows boiler water setback cost savings.
7°F (-13.7°C)	2°F to 10°F (-16.7°C to -12.2°C)	Auxiliary Heat Diff Above The boiler stops when the water temperature rises ‘Diff Above’ degrees above the setpoint.
5°F (-15.0°C)	2°F to 25°F (-16.7°C to -3.9°C)	Auxiliary Heat Diff Below The boiler starts when the water temperature drops ‘Diff Below’ degrees below the setpoint.
3	1 to 5	Response Speed This parameter adjusts the Auxiliary Heat temperature controller Proportion Integral Derivative (PID) values. Higher values cause a larger firing rate change for each degree of temperature change. If set too high, firing rate “overshoots” required value, increases to high fire causing the temperature to exceed the “Diff Above” setpoint and cycle the boiler unnecessarily. Lower values cause a smaller firing rate change for each degree of temperature change. If set too low, the firing rate response will be sluggish and temperature will wander away from setpoint.
Disable	Disable, Enable	Auxiliary Priority Over Central Heat This parameter allows the Auxiliary Heat demand to be higher or lower priority than Central Heat demand. When both demands are active at the same time the Control uses the Setpoint, Diff Above and Diff Below for the demand that has priority. Disable Auxiliary Heat is lower priority than Central Heat demand. Enable Auxiliary Heat is higher priority than Central Heat demand.
Zone Control	Zone Control, DHW Terminal	Auxiliary Heat Demand Source The Control’s “DHW Temp Switch” input terminal may be used as a Domestic Hot Water (DHW) demand or Auxiliary Heat demand. When the Domestic Hot Water Demand Source is set to Zone Control and the Auxiliary Heat Demand Source is set to “DHW Terminal” an Auxiliary Heat Demand may be wired to the DHW Temp Switch terminals. This feature may be used even if a Zone Control is not installed. Zone Control Auxiliary Heat demand may only be wired to the Zone Control DHW Terminal Auxiliary Heat demand may be wired to the Zone Control or DHW Terminal.
Supply Sensor	Supply Sensor, Header Sensor	Modulation Sensor Heat Demand may respond to the boiler’s Supply Temperature or Header Temperature sensors. When Header Sensor is selected the boiler is fired in response to the sensor wired to Header Sensor terminals. NOTE: When Header Sensor is selected, also set Boiler Pump parameter to Header Sensor Demand/Combustion Air Damper.

10 Operation

F. Changing Adjustable Parameters *(continued)*

“Press” Domestic Hot Water button to access the following parameters:

Factory Setting	Range / Choices	Parameter and Description
170°F (76.7°C)	50°F to 190°F (10°C to 87.8°C)	Domestic Hot Water Setpoint The Domestic Hot Water (DHW) Setpoint parameter is used to create a minimum boiler water temperature setpoint that is used when DHW heat demand is “on”. When the DHW heat demand is not “on” (the contact is open or <u>not wired</u>) this setpoint is ignored.
160°F (71.1°C)	50°F to 190°F (10°C to 87.8°C)	Domestic Hot Water Thermostat “Sleep” or “Away” Setback Setpoint Thermostat setback setpoint is used when the EnviraCOM thermostat is in “leave” or “sleep” modes and sensed at E-COM terminals D, R, and C. When setback is “on” the thermostat setback setpoint shifts the DHW setpoint to lower the DHW temperature and to save energy while home is in a reduced room temperature mode.
7°F (-3.9°C)	3°F to 29°F (-16.1°C to 1.7°C)	Domestic Hot Water Diff Above The boiler stops when the water temperature rises ‘Diff Above’ degrees above the setpoint.
5°F (-15.0°C)	3°F to 89°F (-16.1°C to -1.7°C)	Domestic Hot Water Diff Below The boiler starts when the water temperature drops ‘Diff Below’ degrees below the setpoint.
3	1 to 5	Response Speed This parameter adjusts the Domestic Hot Water temperature controller Proportion Integral Derivative (PID) values. Higher values cause a larger firing rate change for each degree of temperature change. If set too high firing rate “overshoots” required value, increases to high fire causing the temperature to exceed the “Diff Above” setpoint and cycle the boiler unnecessarily. Lower values cause a smaller firing rate change for each degree of temperature change. If set too low, the firing rate response will be sluggish and temperature will wander away from setpoint.
10 seconds	0 to 1,800 seconds	Low Fire Hold Time “Low Fire Hold Time” is the number of seconds the control will wait at low fire modulation rate before being released to modulate. After ignition and flame stabilization periods the firing rate is held at low fire for “Low Fire Hold Time”. This delay allows heat to travel out to the indirect water heater and provide feedback prior to the control modulating firing rate.
Enabled	Enable, Disable	Domestic Hot Water Priority (DHWP) When Domestic Hot Water Priority is Enabled and Domestic Hot Water (DHW) heat demand is “on” the DHW demand will take “Priority” over home heating demand. When the System and Boiler pumps are configured as “Central Heat (off DHW priority)” or “Central Heat, Optional Priority” then they will be forced “off” during DHW Priority. Priority protection time is provided to end DHWP in the event of a failed or excessive long DHW demand.
60 min.	0 to 90 min.	Priority Time When DHWP is Enabled the Priority Time Parameter appears and is adjustable.
DHW Terminal	DHW Terminal, Zone Control	Domestic Demand Source Domestic Hot Water demand may respond to the boiler’s DHW Demand terminals or the Sage Zone Control Panel (if used). DHW Terminal: Boiler responds to DHW Demand terminals on boiler low voltage PCB. Zone Control: Boiler responds to Sage Zone Control Panel.
Outlet Sensor	Outlet Sensor, DHW Sensor	DHW Modulation Sensor Outlet Sensor: Boiler modulates for DHW Demand in response to supply/outlet sensor in boiler. DHW Sensor: Boiler modulates for DHW Demand in response to DHW sensor at inlet to indirect water heater. Use for single boiler servicing indirect water heater.

10 Operation

F. Changing Adjustable Parameters *(continued)*

“Press” Outdoor Reset
Central Heat button to access the following parameters:

Factory Setting	Range / Choices	Parameter and Description
Enabled	Enable Disable	<p>Central Heat Outdoor Reset Enable</p> <p>If an outdoor sensor is installed and Outdoor Reset is Enabled, the boiler will automatically adjust the heating zone set point temperature based on the outdoor reset curve in Figure 10-12. The maximum set point is defined by the Central Heat Setpoint [factory set to 180°F (82.2°C)] when the outdoor temperature is 0°F (-18°C) or below. The minimum set point temperature shown is 130°F (54.4°C) [adjustable as low as 80°F (26.7°C)] when the outdoor temperature is 50°F (10°C) or above. As the outdoor temperature falls the supply water target temperature increases. For example, if the outdoor air temperature is 30°F, (-1.1°C) the set point temperature for the supply water is 150°F (65.6°C).</p> <p>Disable Do Not Calculate setpoint based on outdoor temperature Enable Calculate the temperature setpoint based on outdoor temperature using a reset curve defined by Low Outdoor Temp, High Outdoor Temp, Low Boiler Water Temp, Min Boiler Temp, Central Heat Setpoint and Boost Time parameters.</p>
0°F (-18°C)	-50°F to 32°F (-45.6°C to 0°C)	<p>Central Heat Low Outdoor Temperature</p> <p>The Low Outdoor Temperature parameter is also called “Outdoor Design Temperature”. This parameter is the outdoor temperature used in the heat loss calculation. It is typically set to the coldest outdoor temperature.</p>
70°F (21.1°C)	35°F to 100°F (1.7°C to 37.8°C)	<p>Central Heat High Outdoor Temperature</p> <p>The High Outdoor Temperature parameter is the outdoor temperature at which the Low Boiler Water Temperature is supplied. This parameter is typically set to the desired building temperature.</p>
110°F (43.3°C)	70°F to 180°F (21.1°C to 82.2°C)	<p>Central Heat Low Boiler Water Temperature</p> <p>The Low Boiler Water Temperature parameter is the operating setpoint when the High Outdoor Temperature is measured. If the home feels cool during warm outdoor conditions, the Low Boiler Water Temperature parameter should be increased.</p>
130°F (54.4°C)	50°F to 185°F (10°C to 85°C)	<p>Minimum Boiler Temperature (Central Heat and Auxiliary Heat)</p> <p>The Minimum Boiler Temperature parameter sets a low limit for the Reset setpoint. Set this parameter to the lowest supply water temperature that will provide enough heat for the type radiation used to function properly. Always consider the type of radiation when adjusting this parameter.</p>
0 min.	0-30 min.	<p>Central Heat Boost Time</p> <p>When the Central Heat Setpoint is decreased by Outdoor Reset settings, the Boost Time parameter is used to increase the operating setpoint when the home heat demand is not satisfied after the Boost Time setpoint is exceeded. When heat demand has been “on” continuously for longer than the Boost Time parameter the operating setpoint is increased by 10°F (5.6°C). The highest operating setpoint from Boost Time is current Central Heat Setpoint minus the Central Heat “Diff Above” setting. A setting of 0 seconds disables this feature.</p>

10 Operation

F. Changing Adjustable Parameters *(continued)*

“Press” Outdoor Reset
Auxiliary Heat button to access the following parameters:

Factory Setting	Range / Choices	Parameter and Description
Enabled	Enable Disable	<p>Auxiliary Heat Outdoor Reset Enable</p> <p>If an outdoor sensor is installed and Outdoor Reset is Enabled, the boiler will automatically adjust the heating zone set point temperature based on the outdoor reset curve in Figure 10-12. The maximum set point is defined by the Central Heat Setpoint [factory set to 180°F (82.2°C)] when the outdoor temperature is 0°F (-18°C) or below. The minimum set point temperature shown is 130°F (54.4°C) [adjustable as low as 80°F (26.7°C)] when the outdoor temperature is 50°F (10°C) or above. As the outdoor temperature falls the supply water target temperature increases. For example, if the outdoor air temperature is 30°F, (-1.1°C) the set point temperature for the supply water is 150°F (65.6°C).</p> <p>Disable <u>Do Not</u> Calculate setpoint based on outdoor temperature Enable Calculate the temperature setpoint based on outdoor temperature using a reset curve defined by Low Outdoor Temp, High Outdoor Temp, Low Boiler Water Temp, Min Boiler Temp and Central Heat Setpoint and Boost Time parameters.</p>
0°F (-17.8°C)	-50°F to 32°F (-45.6°C to 0°C)	<p>Auxiliary Heat Low Outdoor Temperature</p> <p>The Low Outdoor Temperature parameter is also called “Outdoor Design Temperature”. This parameter is the outdoor temperature used in the heat loss calculation. It is typically set to the coldest outdoor temperature.</p>
70°F (21.1°C)	35°F to 100°F (1.7°C to 37.8°C)	<p>Auxiliary Heat High Outdoor Temperature</p> <p>The High Outdoor Temperature parameter is the outdoor temperature at which the Low Boiler Water Temperature is supplied. This parameter is typically set to the desired building temperature.</p>
110°F (43.3°C)	70°F to 180°F (21.1°C to 82.2°C)	<p>Auxiliary Heat Low Boiler Water Temperature</p> <p>The Low Boiler Water Temperature parameter is the operating setpoint when the High Outdoor Temperature is measured. If the home feels cool during warm outdoor conditions, the Low Boiler Water Temperature parameter should be increased.</p>
0 min.	0-30 min.	<p>Auxiliary Heat Boost Time</p> <p>When the Central Heat Setpoint is decreased by Outdoor Reset settings, the Boost Time parameter is used to increase the operating setpoint when the home heat demand is not satisfied after the Boost Time setting is exceeded. When heat demand has been “on” continuously for longer than the Boost Time parameter the operating setpoint is increased by 10°F (5.6°C). The highest operating setpoint from Boost Time is current Central Heat Setpoint minus the Central Heat “Diff Above” setting. A setting of 0 seconds disables this feature.</p>

10 Operation F. Changing Adjustable Parameters *(continued)*

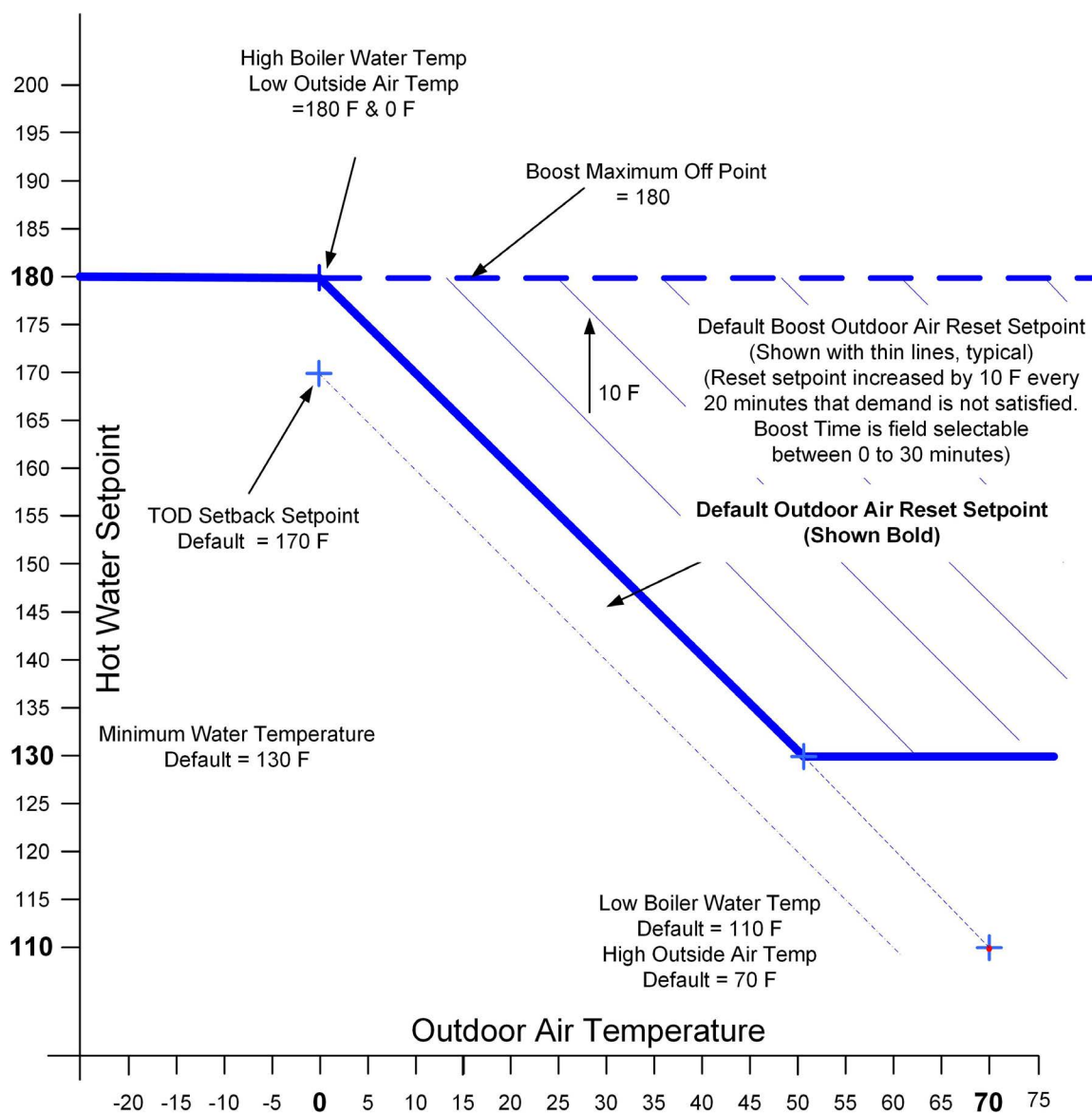
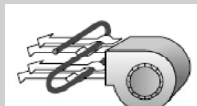
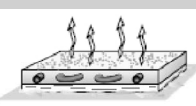
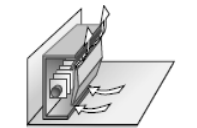
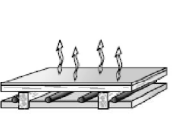

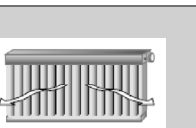

Figure 10-12: Outdoor Reset Curve - Typical for Central Heat and Auxiliary Heat

Central Heat Setpoint	Heating Element Type		Central Heat Setpoint	Heating Element Type	
180°F to 190°F (82.2°C to 87.8°C)	Fan Coil		100°F to 140°F (37.8°C to 60°C)	In Slab Radiant High Mass Radiant	
160°F to 190°F (71.1°C to 87.8°C)	Convection Baseboard Fin Tube Convective		130°F to 160°F (54.4°C to 71.1°C)	Staple-up Radiant Low Mass Radiant	
130°F to 160°F (54.4°C to 71.1°C)	Radiant Baseboard		140°F to 160°F (60°C to 71.1°C)	Radiators	

10 Operation

F. Changing Adjustable Parameters *(continued)*

“Press” Sequence Master button to access the following parameters:

Factory Setting	Range / Choices	Parameter and Description
Disable	Enable, Disable	Master Enable/Disable The Sequencer Master Enable/Disable is used to “turn on” the Multiple Boiler Controller. WARNING! Enable ONLY one Sequence Master.
Boiler Piped	Boiler Piped, Primary Piped	Indirect Water Heater (IWH) Boiler Piped Sequencer to respond to an Isolated DHW demand that is piped to a single boiler. The individual boiler goes on “Leave” from the Sequencer Master and goes to DHW Service. Primary Piped The Sequence Master responds to the DHW Call For Heat. This allows one or more boilers to provide heat to the IWH.
Disabled	Enable, Disable	DHW Two Boiler Start The Sequencer to immediately start two boilers for a DHW call for heat. Used when DHW is the largest demand. Only visible when primary piped IWH is selected.
5 min.	0.5 - 20 min.	Boiler Start Delay Slave boiler time delay after header temperature has dropped below the setpoint minus “Diff below” setpoint. Longer time delay will prevent nuisance starts due to short temperature swings.
195°F (90.6°C)	Central Heat Setpoint to 195°F (90.6°C)	Stop All Boilers Setpoint When this temperature is reached all boilers are stopped. This setpoint allows the Sequencer to respond to rapid load increases.
70%	25% - 100%	Base Load Common Rate To maximize condensing boiler efficiency, the firing rate is limited to an adjustable value. Boilers are kept at or below this firing rate as long as the boilers can handle the load. After last available boiler has started, the modulation rate limit is released up to 100%.
3	0-5	Response Speed This parameter adjusts the Sequence Master temperature controller Proportion Integral Derivative (PID) values. Higher values cause a larger firing rate change for each degree of temperature change. If set too high firing rate “overshoots” required value, increases to high fire causing the temperature to exceed the “Diff Above” setpoint and cycle the boiler unnecessarily. Lower values cause a smaller firing rate change for each degree of temperature change. If set too low, the firing rate response will be sluggish and temperature will wander away from setpoint.

“Press” Sequence Slave button to access the following parameters:

Factory Setting	Range / Choices	Parameter and Description
None	1-8	Boiler Address Each boiler must be given a unique address. When “Normal” slave selection order is used, the boiler address is used by the Master Sequencer as the boiler start order. The boiler address is also the Modbus Address when a Energy Management System is connected.
Normal	Use Boiler First, Normal, Use Boiler Last	Slave Selection Order “Use Boiler First”; places the Slave in the lead permanently. “Normal”; firing order follows boiler number (1,2,3,..) order. “Use Boiler Last”; places the slave last in the firing order.

10 Operation

F. Changing Adjustable Parameters *(continued)*

“Press”

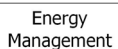

button to access the following parameters:

Factory Setting	Range / Choices	Parameter and Description
Local	Local, 4-20mA, Modbus	<p>Central Heat Modulation Source</p> <p>This parameter enables the 4-20mA input to control firing rate and the thermostat input to control boiler on/off demand directly without using the internal setpoint. The 4-20mA selection is used to enable a remote multiple boiler controller to control the Sage2.2 Control:</p> <p>Local: 4-20mA Input terminals ignored.</p> <p>4-20mA 4-20mA Input terminals used to control firing Rate % directly.</p> <p>Modbus Modbus input used to control firing Rate % directly.</p>
Local	Local, 4-20mA, Modbus	<p>Central Heat Setpoint Source</p> <p>Sets the remote (Energy Management System) control mode as follows:</p> <p>Local: Local setpoint and modulation rate is used. 4-20mA input terminals are ignored.</p> <p>4-20mA 4-20mA Input terminals are used as the temperature setpoint. The following two parameters may be used to adjust the signal range.</p> <p>Modbus Modbus is used as the temperature setpoint.</p>
130°F (54.4°C)	80°F (26.7°C) - Central Heat Setpoint	<p>Central Heat 4-20mADC Setup, 4 mA Water Temperature*</p> <p>Sets the Central Heat Temperature Setpoint corresponding to 4mA for signal input terminals. Current below 4mA is considered invalid, (failed or incorrect wired input).</p>
180°F (82.2°C)	80°F (26.7°C) - Central Heat Setpoint	<p>Central Heat 4-20mADC Setup, 20 mA Water Temperature*</p> <p>Sets the Central Heat Temperature Setpoint corresponding to 20mA for signal input terminals. Current above 20mA is considered invalid, (failed or incorrect wired input).</p>
Local	Local, Modbus	<p>Central Heat Demand Source</p> <p>This parameter enables a Modbus input to be take the place of the Heating Thermostat Input:</p> <p>Local Local Heating Thermostat input is used for Central Heat demand.</p> <p>Modbus Modbus input is used for Central Heat demand.</p>

* Only visible when Central Heat Setpoint Source is set to 4-20mA.

10 Operation

F. Changing Adjustable Parameters *(continued)*

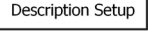
“Press”  button to access the following parameters:

NOTE

Zone Control Description Setup shown for 2 panels, typical for up to 4.

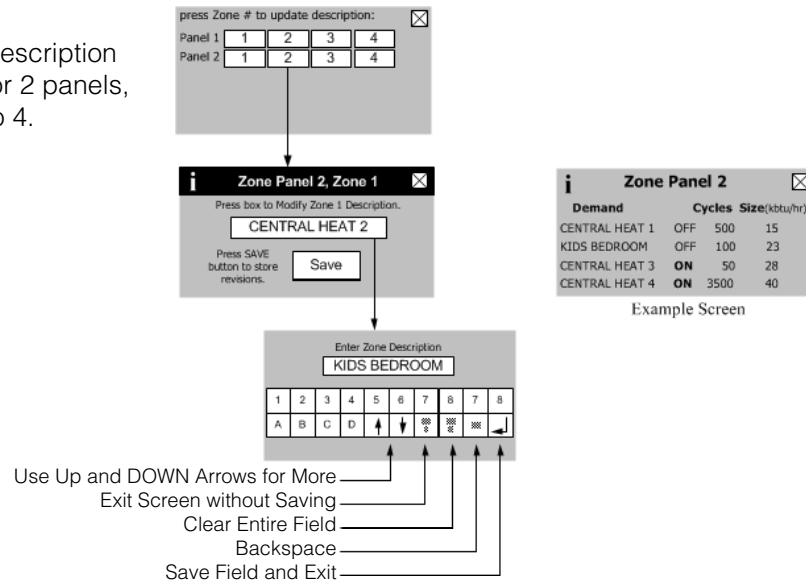

Factory Setting	Range / Choices	Parameter and Description	
Central Heat 1	User defined	Zone Control 1	Zone 1
Central Heat 2	User defined	Zone Control 1	Zone 2
Central Heat 3	User defined	Zone Control 1	Zone 3
Central Heat 4	User defined	Zone Control 1	Zone 4
Central Heat 1	User defined	Zone Control 2	Zone 1
Central Heat 2	User defined	Zone Control 2	Zone 2
Central Heat 3	User defined	Zone Control 2	Zone 3
Central Heat 4	User defined	Zone Control 2	Zone 4
Central Heat 1	User defined	Zone Control 3	Zone 1
Central Heat 2	User defined	Zone Control 3	Zone 2
Central Heat 3	User defined	Zone Control 3	Zone 3
Central Heat 4	User defined	Zone Control 3	Zone 4
Central Heat 1	User defined	Zone Control 4	Zone 1
Central Heat 2	User defined	Zone Control 4	Zone 2
Central Heat 3	User defined	Zone Control 4	Zone 3
Central Heat 4	User defined	Zone Control 4	Zone 4

11 Service and Maintenance

Important Product Safety Information: Refractory Ceramic Fiber Product

WARNING

Some boiler components use materials that contain refractory ceramic fibers (RCF). RCF has been classified as a possible human carcinogen. When exposed to elevated temperatures, RCF may change into crystalline silica, a known carcinogen. When disturbed as a result of servicing or repair, these substances become airborne and, if inhaled, may be hazardous to your health. Avoid breathing RCF particulates and dust.

Precautionary Measures:

- Do not handle RCF parts or attempt any service or repair work involving RCF without wearing the following protective gear:
 1. A properly fitting National Institute for Occupational Safety and Health (NIOSH)-certified air-purifying respirator with a filter efficiency of at least 95%. Respirator should also include a full facepiece when handling used RCF. Other types of respirators may be required depending on site conditions. Current NIOSH recommendations may be found on the NIOSH website <http://www.cdc.gov/niosh/homepage.html>. NIOSH-approved manufacturers, respirators and associated user instructions are listed on the NIOSH website.
 2. Long sleeved, loose fitting clothing that is sufficiently tight around potential entry points for RCF dust.
 3. Gloves.
 4. Eye protection, such as goggles, safety glasses with side shields, or full facepiece.
- Take steps to assure adequate ventilation.
- Handle RCF carefully to minimize airborne dust. Use hand tools whenever possible.
- Dampen used RCF with light water spray prior to removal to prevent airborne dust.
- Do not use compressed air or dry sweeping for clean-up. Frequently clean work area with a vacuum or by wet sweeping to minimize debris accumulation.
- Vacuum work clothes before leaving work area. Wash work clothes separately from other laundry and rinse washing machine after use to avoid contaminating other clothes.
- Wash all exposed body areas gently with soap and water after contact.
- Discard used RCF components by sealing in an airtight plastic bag or container. Refer to local, regional, state or provincial regulations to identify applicable disposal requirements.

First Aid Procedures:

- Eye contact: Flush with water for at least 15 minutes. Do not rub eyes. Seek immediate medical attention if irritation persists.
- Skin contact: Wash affected area gently with soap and water. Do not rub or scratch affected skin. Seek immediate medical attention if irritation persists.
- Nose and throat contact: If these become irritated, leave the area and move to a location with clean fresh air. Drink water and blow nose. Seek immediate medical attention if symptoms persist.

11 Service and Maintenance *(continued)*

WARNING

Asphyxiation Hazard. This boiler requires regular maintenance and service to operate safely. Follow the instructions contained in this manual.

- Improper installation, adjustment, alteration, service or maintenance can cause property damage, personal injury or death. Read and understand the entire manual before attempting installation, start-up operation, or service. Installation and service must be performed only by an experienced, skilled, and knowledgeable installer or service agency.
- This boiler must be properly vented.
- This boiler needs fresh air for safe operation and must be installed so there are provisions for adequate combustion and ventilation air.
- **Asphyxiation Hazard.** The interior of the venting system must be inspected and cleaned before the start of the heating season and should be inspected periodically throughout the heating season for any obstructions. A clean and unobstructed venting system is necessary to allow noxious fumes that could cause injury or death to vent safely and will contribute toward maintaining the boiler's efficiency.
- Installation is not complete unless a safety relief valve is installed into the tapping located on left side of appliance or the supply piping. - See the Water Piping and Trim Section of this manual for details.
- This boiler is supplied with safety devices which may cause the boiler to shut down and not re-start without service. If damage due to frozen pipes is a possibility, the heating system should not be left unattended in cold weather; or appropriate safeguards and alarms should be installed on the heating system to prevent damage if the boiler is inoperative.
- **Burn Hazard.** This boiler contains very hot water under high pressure. Do not unscrew any pipe fittings nor attempt to disconnect any components of this boiler without positively assuring the water is cool and has no pressure. Always wear protective clothing and equipment when installing, starting up or servicing this boiler to prevent scald injuries. Do not rely on the pressure and temperature gauges to determine the temperature and pressure of the boiler. This boiler contains components which become very hot when the boiler is operating. Do not touch any components unless they are cool.
- **Respiratory Hazard.** Boiler materials of construction, products of combustion and the fuel contain alumina, silica, heavy metals, carbon monoxide, nitrogen oxides, aldehydes and/or other toxic or harmful substances which can cause death or serious injury and which are known to the state of California to cause cancer, birth defects and other reproductive harm. Always use proper safety clothing, respirators and equipment when servicing or working nearby the appliance.
- Failure to follow all instructions in the proper order can cause personal injury or death. Read all instructions, including all those contained in component manufacturers manuals which are provided with the boiler before installing, starting up, operating, maintaining or servicing.
- All cover plates, enclosures and guards must be in place at all times.

NOTICE: This boiler has a limited warranty, a copy of which is printed on the back of this manual. It is the responsibility of the installing contractor to see that all controls are correctly installed and are operating properly when the installation is complete.

11 Service and Maintenance *(continued)*

DANGER

Explosion Hazard. Electrical Shock Hazard. Burn Hazard. This boiler uses flammable gas, high voltage electricity, moving parts, and very hot water under high pressure. Assure that all gas and electric power supplies are off and that the water temperature is cool before attempting any disassembly or service.

- Do not attempt any service work if gas is present in the air in the vicinity of the boiler. Never modify, remove or tamper with any control device.

WARNING

This boiler must only be serviced and repaired by skilled and experienced service technicians.

- If any controls are replaced, they must be replaced with identical models.
- Read, understand and follow all the instructions and warnings contained in all the sections of this manual.
- If any electrical wires are disconnected during service, clearly label the wires and assure that the wires are reconnected properly.
- Never jump out or bypass any safety or operating control or component of this boiler.
- Read, understand and follow all the instructions and warnings contained in ALL of the component instruction manuals.
- Assure that all safety and operating controls and components are operating properly before placing the boiler back in service.
- Annually inspect all vent gaskets and replace any exhibiting damage or deterioration.

NOTICE: Warranty does not cover boiler damage or malfunction if the following steps are not performed at the intervals specified.

3. Inspect the water and gas lines to verify they are free from leaks. Call the service technician to make repairs if required.

A. Continuously:

1. Keep the area around the boiler free from combustible materials, gasoline and other flammable vapors and liquids.
2. Keep the area around the combustion air inlet terminal free from contaminants.
3. Keep the boiler room ventilation openings open and unobstructed.

NOTICE: Water leaks can cause severe corrosion damage to the boiler or other system components. Immediately repair any leaks found.

B. Monthly Inspections:

1. Inspect the vent piping and outside air intake piping to verify they are open, unobstructed and free from leakage or deterioration. Check screens in vent and air intake terminations to verify they are clean and free of debris. Call the service technician to make repairs if needed.
2. Inspect the condensate drain system to verify it is leak tight, open and unobstructed. Call the service technician if the condensate drain system requires maintenance.

C. Annual Inspections and Service:

In addition to the inspections listed above the following should be performed by a service technician once every year.

1. Test the flow switch by disabling the boiler primary loop circulator. The boiler must not start when there is not water flow.
2. Follow the procedure for turning the boiler off per Figure 9-1 "Operating Instructions".
3. Inspect the wiring to verify the conductors are in good condition and attached securely.

11 Service and Maintenance *(continued)*

⚠ CAUTION / ATTENTION

Electrical Shock Hazard. Label all wires prior to disconnection when servicing controls. Wiring errors can cause improper and dangerous operation. Verify proper operation after servicing.
 Au moment de l'entretien des commandes, étiquetez tous les fils avant de les débrancher. Les erreurs de câblage peuvent nuire au bon fonctionnement et être dangereuses. S'assurer que l'appareil fonctionne adéquatement une fois k'entretien terminé.

- Remove the igniter assembly and flame sensor and inspect them for oxide deposits. Clean the oxide deposits from the igniter electrodes and flame sensor rod with steel wool. Do not use sandpaper for the cleaning. Inspect the ceramic insulators for cracks and replace the igniter assembly and/or flame sensor if necessary. Check the igniter electrode spacing gap. Refer to Figure 11-1 "Igniter Electrode Gap" for details.

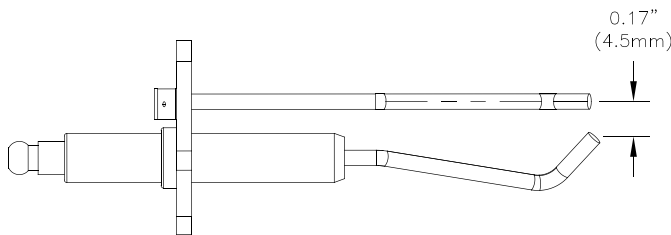

Figure 11-1: Igniter Electrode Gap

- To gain access to boiler burner and combustion chamber, first disconnect and remove gas inlet piping from gas valve. Then, remove six M6X1 hex flange nuts and take out the burner/blower/gas valve assembly from the boiler. To prevent stud breakage, apply a generous amount of good quality penetrating oil to nuts and let it soak in prior to attempting nut removal.
- Inspect the assembly for lint and dust presence. If significant lint and dust accumulations are found, disassemble the blower/gas valve assembly to expose the swirl plate and blower inlet. For parts identification, refer to Section 13 "Service Parts". Vacuum these parts as required, being careful not to damage the vanes on the swirl plate.
- Vacuum any dust or lint from the burner if present. If the burner shows any visual deterioration or corrosion signs, replace it immediately. Inspect the burner gasket and replace if necessary.
- Inspect the heat exchanger combustion chamber, clean and vacuum any debris found on the surfaces. If required, brush the coils of the heat exchanger using a non-abrasive, non-metal bristle brush. Any cleaning of the combustion chamber

with acid or alkali products is prohibited. Do not use any cleaning agents or solvents. If insulation disc has signs of damage, it must be replaced.

- Inspect the condensate trap to verify it is open and free from debris. Inspect condensate line integrity between boiler and condensate neutralizer (if used), condensate neutralizer and the drain. Clean/repair if needed.
 If the condensate neutralizer is used, check pH before and after the neutralizer to determine neutralizing effectiveness. Replace limestone chips and clean out the neutralizer if needed.
- Inspect vent connections and vent connector to heat exchanger seals to verify that they are free from leakage and deterioration. Repair as needed. Follow all instructions in Section 4 "Venting" when reassembling vent system.
- Check vent and air intake terminal for obstructions and clean as necessary. Check screens in vent and air intake terminations to verify they are clean and free of debris.

⚠ WARNING

Failure to properly secure the burner/blower/gas valve assembly to the heat exchanger could lead to property damage, personal injury or death.

- Reinstall the burner/blower/gas valve assembly and secure with M6X1 hex flange nuts.
- Reconnect any wiring which has been disconnected.
- Verify that the system pH is between 7.5 and 9.5.
- Inspect the heating system and correct any other deficiencies prior to restarting the boiler.
- Follow Section 9 "System Start-up" before leaving installation.
- Perform the combustion test outlined in Section 9 "System Start-up".

D. Recommended Heating System Water Treatment Products:

- System Cleaning and Conditioning:
 - The following heating system water treatment products are recommended for an initial existing heating system sludge removal, initial boiler cleaning from copper dust, flux residue, any boiler debris and for preventive treatment as corrosion/scale inhibitors:
 - Fernox™ Restorer (universal cleaner, sludge remover, scale remover, flux residue/debris remover, corrosion inhibitor)
 - Fernox™ Protector (Alphi 11, CH#, Copal) (sludge remover, corrosion inhibitor)

11 Service and Maintenance *(continued)*

Follow manufacturer application procedure for proper heating system/boiler cleaning and preventive treatment.

Above referenced products are available from Alent plc, Consumer Products Division, 4100 6th Avenue, Altoona, PA 16602, Tel: (972) 547-6002 and/or selected HVAC distributors. Contact U.S. Boiler Company for specific details.

- iii. Sentinel® X400 System Restorer (For Older Closed Loop Hydronic Heating Systems)
- iv. Sentinel® X300 System Cleaner (For New Heating Systems)
- v. Sentinel® X100 Inhibitor (For Protecting Closed Loop Hydronic Heating Systems Against Lime scale And Corrosion)

Follow manufacturer application procedure for proper heating system/boiler cleaning and preventive treatment.

Above referenced products are available from Douglas Products and Packaging, 1550 E. Old 210 Highway, Liberty, MO 64068, Tel:(877) 567-2560 (Toll Free) and/or selected HVAC distributors.

2. System Freeze Protection:

- a. The following heating system freeze protection products are recommended for Alpine boilers:
 - i. Fernox™ Protector Alphi 11 (combined antifreeze and inhibitor).

Follow manufacturer application procedure to ensure proper antifreeze concentration and inhibitor level.

Above referenced product is available from Alent plc, Consumer Products Division, 4100 6th Avenue, Altoona, PA 16602, Tel: (972) 547-6002 and/or selected HVAC distributors. Contact U.S. Boiler Company for specific details.

- ii. Sentinel® X500 Inhibited Antifreeze (combined antifreeze and inhibitor)

Follow manufacturer application procedure to ensure proper antifreeze concentration and inhibitor level.

Above referenced products are available from Douglas Products and Packaging, 1550 E. Old 210 Highway, Liberty, MO 64068, Tel:(877) 567-2560 (Toll Free) and/or selected HVAC distributors.

- b. Equivalent system freeze protection products may be used in lieu of product referenced above. In general, freeze protection for new or existing systems must use specially formulated glycol, which contains inhibitors, preventing the glycol from attacking the metallic system components. Ensure that system fluid contains proper glycol concentration and inhibitor level. The system should be tested at least once a year and as recommended by the manufacturer of the glycol solution. Allowance should be made for expansion of the glycol solution.

! WARNING

Poison Hazard. Use only inhibited propylene glycol solutions specifically formulated for hydronic systems. Do not use ethylene glycol, which is toxic and can attack gaskets and seals used in hydronic systems. Use of ethylene glycol could result in property damage, personal injury or death.

E. Condensate Overflow Switch and Condensate Trap Removal and Replacement:

For removal or replacement of the condensate overflow switch and/or condensate trap follow the steps below. For parts identification, refer to Section 13 "Service Parts".

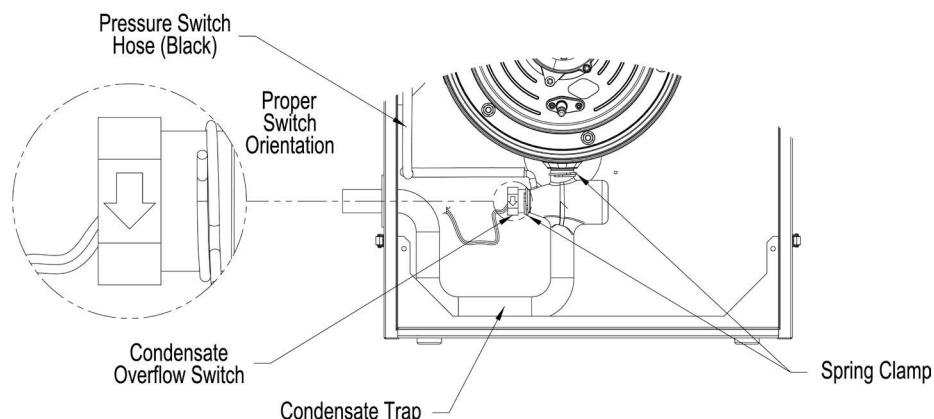

Figure 11-2: Condensate Overflow Switch Orientation

11 Service and Maintenance *(continued)*

1. Condensate Overflow Switch Removal and Replacement:

- Disconnect power supply to boiler.
- Remove 2 wire nuts and disconnect overflow switch wire pigtailed from boiler wiring.
- Using pliers, release spring clip securing the overflow switch to condensate trap body and remove the switch. Note that the switch has factory applied silicon adhesive seal, which may have to be carefully cut all around to facilitate the switch removal.
- Ensure the trap overflow switch port is not obstructed with silicon seal debris, clean as needed.
- Apply silicon sealant to the replacement switch threads and install the switch into the trap body making sure it is properly oriented - the arrow molded into the switch hex end side must face down for proper switch operation. See Figure 11-2 "Condensate Overflow Switch Orientation" for details.
- Reconnect the switch wire pigtailed to the boiler wiring and secure with wire nuts.
- Restore power supply to boiler. Fill up the trap

(see Section 5 "Condensate Disposal") and verify the switch operation.

2. Condensate Trap Removal and Reinstallation:

- Disconnect power supply to boiler.
- Remove 2 wire nuts and disconnect overflow switch wire pigtailed from boiler wiring.
- Disconnect pressure switch hose from condensate trap.
- Disconnect outside condensate compression fitting from condensate trap.
- Using pliers, release spring clip securing the overflow switch to condensate trap body and remove the switch. Note that the switch has factory applied silicon adhesive seal, which may have to be carefully cut all around to facilitate the switch removal.
- Using pliers, release spring clip securing condensate trap body to the heat exchanger bottom drain connection.
- First, pull the trap downwards to release from the heat exchanger. Second, pull the trap end from left side jacket panel sealing grommet and remove the trap from boiler.
- To reinstall the trap, reverse above steps.

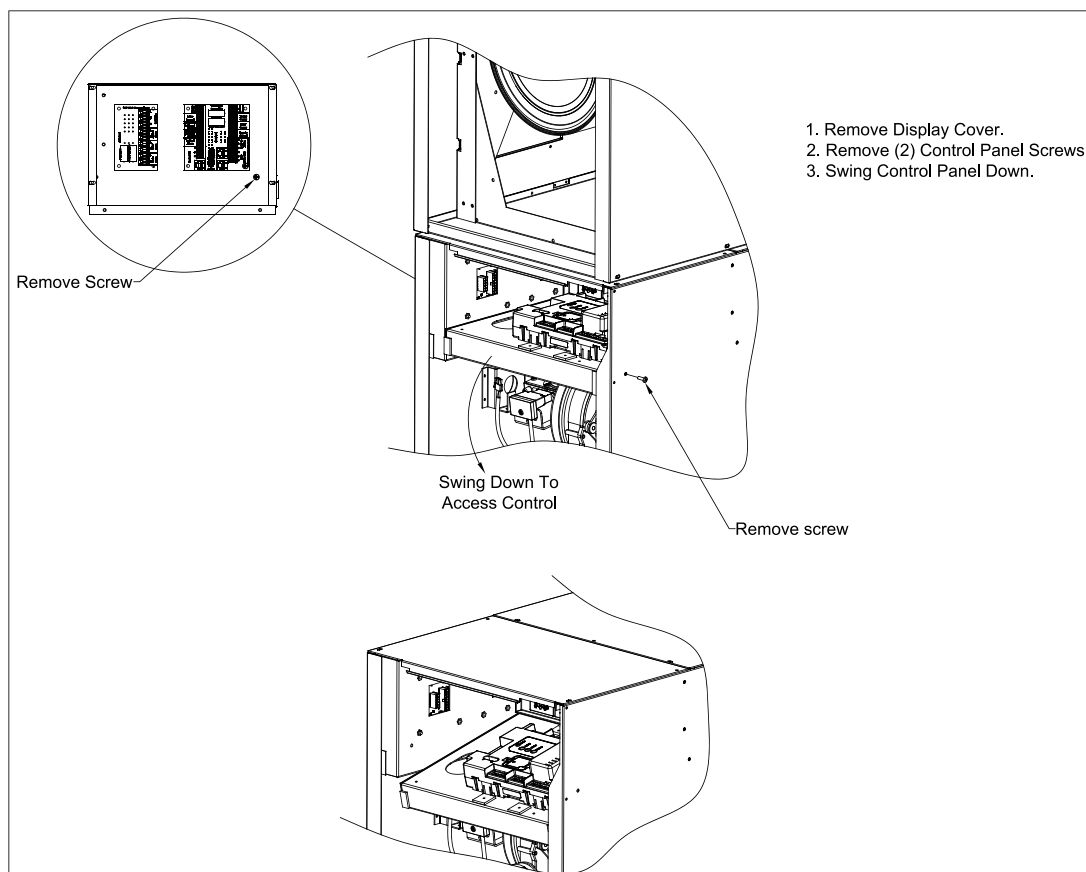

Figure 11-3: Control Compartment Access for Stacked Boiler Installations

11 Service and Maintenance *(continued)*

- i. If the original condensate overflow switch is to be re-used, follow the appropriate switch removal steps from Condensate Overflow Switch Removal and Replacement procedure.
- j. Ensure that fresh silicon sealant is applied to the overflow switch threads and the switch is properly oriented relative to the trap body - the arrow molded into the switch hex side end must face down for proper switch operation. See Figure 11-2 "Condensate Overflow Switch Orientation" for details.
- k. Ensure that pressure switch hose is reconnected to the trap.
- l. Restore power supply to boiler. Fill up the trap (see Section 5 "Condensate Disposal") and verify the switch operation.

F. Control Compartment Access

1. Non-stacked boiler installations: Remove top front panel to access control compartment.
2. Stacked boiler installations: Remove front door and display panel. As shown in Figure 11-3, remove two screws, one inside junction box and one on right side panel. Swing control panel downward to access control compartment.

12 Troubleshooting

⚠ WARNING

Electrical Shock Hazard. Turn off power to boiler before working on wiring.

A. Troubleshooting problems where no error code is displayed.

Condition	Possible Cause
Boiler not responding to call for heat, "Status" and "Priority" show "Standby".	Boiler is not seeing call for heat. Check thermostat or zone wiring for loose connection, mis-wiring, or defective thermostat/zone control.
Boiler not responding to a call for heat, "Status" shows "Standby" and "Priority" shows Central Heat or Domestic Hot Water.	Boiler is not firing, temperature is greater than setpoint. Water flow through boiler primary loop non-existent or too low.
Boiler Running but System or Boiler Circulator is not running	<ul style="list-style-type: none"> Check wiring for loose connection, mis-wiring. When there is a Domestic Hot Water Heat Request the System or Boiler pumps will be forced "off" when the "Run Pump for" parameter is set to "Central heat, off DHW demand" or "Central Heat, Optional Priority". This has been set to allow all of the heat to be provided for fast indirect water heater recovery. After one hour of "priority protection" or the end of the Domestic Hot Water Heat Request the system and boiler pumps will be free to run.
Home is cold during mild weather days	<ul style="list-style-type: none"> Increase Low Boiler Water Temperature parameter 5°F (2.8°C) per day.
Home is cold during cold weather days	<ul style="list-style-type: none"> Increase High Boiler Water Temperature parameter 5°F (2.8°C) per day

B. Display Faults:

Faults are investigated by selecting the "Help" button from the "Home" screen. When a fault is active the "Help" button flashes and the home screen turns a red color. Continue to select flashing buttons to be directed to the Fault cause.

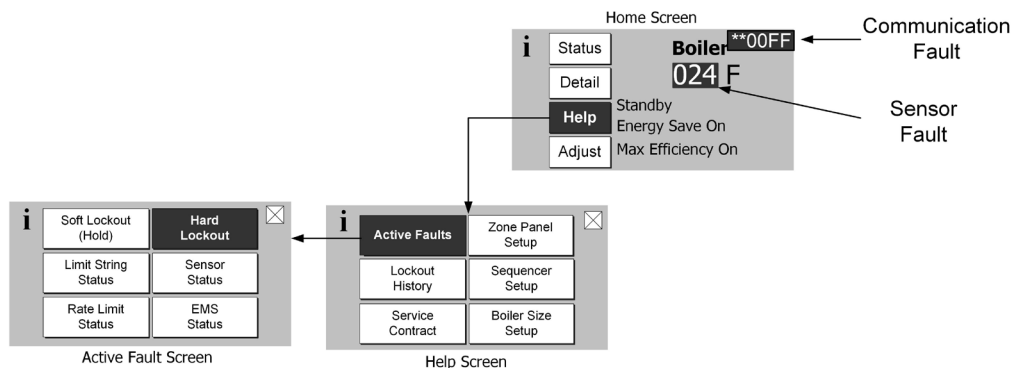

Figure 12-1: Help Menu

Indication	Condition	Possible Cause
Display Completely Dark Fan off, LWCO lights off, no green power light on Control	No 120 VAC Power at Boiler	Check breaker and wiring between breaker panel and boiler.
Display Completely Dark, Fan running	No 24 VAC Power to Control	<ul style="list-style-type: none"> - Loose 120 VAC connection wiring between boiler J-Box and transformer - Loose 24 VAC connection wiring between transformer and Control.
Blinking Green power light on Control	Control Fault	<ul style="list-style-type: none"> - The green light is connected to internal power supply. The power supply is repeatedly starting and stopping (not normal) making the light flash. The microprocessors are not running. - Try disconnecting all terminals except 24 VAC to power the Control. The green light should be steady. If it is not, then the control is defective. If steady, start plugging in all the connectors while watching the green light. When faulty wiring reconnected, green light will begin to flash.
Display Completely Dark but Boiler fires	No 5 VDC Power to Display	<ul style="list-style-type: none"> - Loose 5 VDC connection wiring between display and Control - Defective Display or Control.
**00FF or **ERFF	display lost communication with control	<ul style="list-style-type: none"> - Loose or defective display harness - Defective Display - Defective Control
ER0011	Adjustment Mode Password Timeout	- The Control and Display are NOT defective. The password has timed out. Simply cycle power to the Display to restore operation.
ER0012	Control Failed	Defective Control. Replace Sage.

12 Troubleshooting *(continued)*

C. Help Screen Faults

Indication	Condition	Possible Cause
<div style="background-color: black; color: white; padding: 5px; text-align: center; width: fit-content; margin: 0 auto;">Zone Panel Setup</div> Flashing	<div style="background-color: black; color: white; padding: 5px; text-align: center; width: fit-content; margin: 0 auto;">Zone Panel 1 Setup</div> Flashing	Zone Panel 1 communication lost, typical for Panel 1 through 4: The zone panel's communication was established and then lost. Check the following to correct the issue: <ul style="list-style-type: none"> • Wiring between panel and boiler. • Zone panel DIP switch settings have changed: <ul style="list-style-type: none"> - Set Master/Slave switch to "Master" - Set Zone Control switch ZC1 to "ON" - Cycle power
	<div style="background-color: black; color: white; padding: 5px; text-align: center; width: fit-content; margin: 0 auto;">Zone Panel Failure</div> Flashing	Zone Panel Electronics Failure: A Zone Panel
	<div style="background-color: black; color: white; padding: 5px; text-align: center; width: fit-content; margin: 0 auto;">Duplicate Zone</div> Flashing	Duplicate Zone: The Control has detected duplicate zone panel numbers. Check the following to correct: <ul style="list-style-type: none"> • Each Zone Control DIP Switch must be set to a Unique setting: <div style="text-align: center; margin: 10px 0;"> </div> Note that when multiple ZC switches are set on ON the Zone Panel is reported as Zone Panel 1.
<div style="background-color: black; color: white; padding: 5px; text-align: center; width: fit-content; margin: 0 auto;">Sequencer Setup</div>	Sequencer Setup Fault	This alarm is active if the slave boiler has lost communication with the Sequence Master. Check the following: <ul style="list-style-type: none"> - RJ 45 peer-to-peer network disconnected - Sequencer Master was Enabled and then Disabled - Master Boiler has been powered down. - To clear fault restore communication or cycle power
<div style="background-color: black; color: white; padding: 5px; text-align: center; width: fit-content; margin: 0 auto;">Boiler Size Setup</div>	Boiler Size Fault	<p style="text-align: center;">WARNING!</p> Boiler size setting may not match actual boiler size. The Boiler size setting determines min, max and light-off blower speeds. Incorrect boiler size can cause hazardous burner conditions and improper operation that may result in PROPERTY LOSS, PHYSICAL INJURY, OR DEATH. Refer to section 10 "Modulation Setup" for boiler size setting instructions.

D. Help Screen Diagnostic Features

Indication	Possible Cause
	Lockout History is stored in a first-in, first-out basis. Each History file is stored with boiler run hour of when the lockout occurred. The "When happened" and "Current" provide: <ul style="list-style-type: none"> - "Current" is the run hour and status the boiler just finished. - "When happened" is the run hour and status when the lockout occurred.
For Service Contact: <input checked="" type="checkbox"/> CONTRACTOR NAME CONTRACTOR ADDRESS 1 CONTRACTOR ADDRESS 2 PHONE NUMBER	The user is given the contact information of the responsible service provider. Refer to section 10 "Contractor Setup" for data entry instructions.

12 Troubleshooting *(continued)*

E. Active Fault Screen Faults

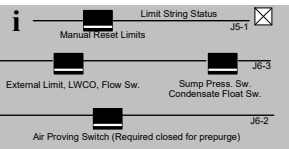
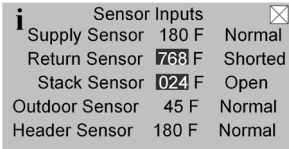
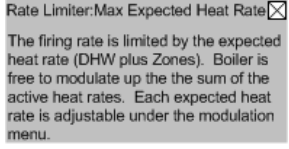
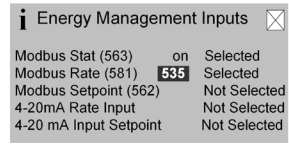
Indication	Condition	Possible Cause
<p>Limit String Status</p> 	Limit String Fault	<p>The Limit String Status screen shows the faulty safety limit. A contact icon, either "open" or "closed", graphically represents each safety limit. The "closed" contact icon is steady; the "open" contact icon is blinking. For example, the screen shown to the left illustrates a "closed" Air Pressure Switch contact and an "open" Auto Reset High Limit contact. The Auto Reset High Limit is causing the boiler to stop firing.</p> <p>NOTE: Since the limit string items are wired in series, all limits downstream of the "open" limit will also appear on the screen as "open" (blinking) icons regardless of whether or not they are actually open.</p>
<p>Sensor Status</p> 	Sensor Fault	<p>The Sensor Status screen shows the status of all sensors. Possible states include:</p> <p>None: Feature requiring this sensor has not been selected. Normal: Sensor is working normally. Shorted: Sensor is shorted or is defective. Open: There is a break in the wiring between the Control and the sensor or the sensor is defective Out of Range: Sensor is defective or is being subjected to electrical noise. Unreliable: Sensor is defective or is being subjected to electrical noise.</p> <p>When a sensor fails "opened" or "shorted" the value is changed to reverse video (background black and value white) "024" or "768" respectively to indicate that there is a fault with the sensor.</p>
<p>Rate Limit</p> 	Rate Limit	<p>The following messages appear when the firing rate is limited or reduced to help avoid a lock-out or save energy.</p> <p>Refer to Hard Lockout section for corrective actions</p> <ul style="list-style-type: none"> - High Stack Temperature Limit - High Supply Temperature Limit - High Differential Temperature Limit <p>The following messages appear as part of normal start and stop sequences:</p> <ul style="list-style-type: none"> - Minimum Modulation (normal start/stop sequence) - Low Fire Hold Rate: Low fire hold rate is a normal start-up rate hold used to help ensure system temperature feedback prior to release to modulation. Low Fire Hold Time may be adjusted. Refer to the "Changing Adjustable Parameters", Paragraph F, for additional information. - Maximum Expected Heat Rate: Maximum Expected Heat Rate limit is a normal start-up rate hold used to save energy. This limit helps reduce extra cycles and save energy. Boiler is free to modulate up to the sum of the active zones and domestic hot water expected heat rates. Each zone heat rate is adjustable and may be modified under the modulation menu. Refer to the "Changing Adjustable Parameters", Paragraph F, for additional information.
<p>EMS Status</p> 	Energy Management System Fault	<p>The Energy Management System (EMS) fault screen provides input fault status. When an input is shown as "Not Selected" it is not required for this application or has not yet been selected. These options are selected under the "Energy Management" Adjust mode menu.</p> <p>Modbus Input Failure If a modbus input is selected and out of range or not present a "535" value is shown reverse video (background black and value white). To fix the problem check the input source and check that the input is properly connected.</p> <p>4-20mA Input Failure Failure status for the 4-20mA input is the same as shown under Sensor Fault.</p>

12 Troubleshooting *(continued)*

F. Troubleshooting problems where a Soft Lockout Code is displayed. When a soft lockout occurs, the boiler will shut down, the display will turn red and the “Help” button will “blink”. Select the “blinking” “Help” button to determine the cause of the soft lockout. The boiler will automatically restart once the condition that caused the lockout is corrected.

Soft Lockout Codes Displayed

Lockout Number	Condition	Possible Cause
1 Anti Short Cycle	Minimum time between starts has not been reached. Normal delay used to avoid excessive cycles.	
2 Boiler Recycling Limits Open (LCI OFF)	LCI safety limit input not energized.	Limit Control Input (LCI) is not ON. Refer to Limit String Status screen for list of limits. <ul style="list-style-type: none"> • Auto Reset Ext. Limit device open or jumper not installed • Low water condition (if using 24V LWCO) • Flow switch open. Check boiler pump and flow switch wiring. • Sump pressure switch open. Check for vent or combustion air pipe blockage. • Condensate float switch open. Check for condensate drain blockage. • Loose or defective limit string wiring
3 Burner Interlock Open (ILK OFF)	ILK safety limit input not energized.	Lockout input (ILK) is not ON. Refer to Limit String Status screen for list of limits. <ul style="list-style-type: none"> • Man Reset Ext. Limit device open or jumper not installed • High or low gas pressure switch open or jumper not installed • Thermal link open • Burner door thermostat open • Loose or defective limit string wiring
7 Return sensor fault	Shorted or open return temperature sensor.	<ul style="list-style-type: none"> • Shorted or mis-wired return sensor wiring. • Defective return sensor.
8 Supply sensor fault	Shorted or open supply temperature sensor.	<ul style="list-style-type: none"> • Shorted or mis-wired supply sensor wiring. • Defective supply sensor.
9 DHW sensor fault	Shorted or open Domestic Hot Water (DHW) temperature sensor.	<ul style="list-style-type: none"> • Shorted or mis-wired DHW sensor wiring. • Defective DHW sensor.
10 Stack sensor fault	Shorted or open flue gas (stack) temperature sensor.	<ul style="list-style-type: none"> • Shorted or mis-wired flue temperature sensor wiring. • Defective flue temperature sensor.
11 Ignition failure	Model ALP399C flame failure after 5 tries to restart.	<ul style="list-style-type: none"> • No gas pressure. • Gas pressure under minimum value shown on rating plate. • Gas line not completely purged of air. • Defective Electrode. • Loose burner ground connection. • Defective Ignition Cable. • Defective gas valve (check for 24 VAC at harness during trial for ignition before replacing valve). • Air-fuel mixture out of adjustment - consult factory.
13 Flame rod shorted to ground	Flame rod shorted to ground	<ul style="list-style-type: none"> • Shorted or mis-wired flame rode wiring. • Defective flame rod.
14 DT inlet/outlet high	Temperature rise between supply and return is too high.	<ul style="list-style-type: none"> • Inadequate boiler water flow. Verify that circulator is operating and that circulator and piping are sized per Section 6 of this manual.
15 Return temp higher than supply	The Control is reading a return sensor temperature higher than the supply sensor temperature. Condition must be present for at least 75 seconds for this error code to appear.	<ul style="list-style-type: none"> • Flow through boiler reversed. Verify correct piping and circulator orientation. • No boiler water flow. Verify that system is purged of air and that appropriate valves are open. • Sensor wiring reversed. • Supply or return sensor defective.
16 Supply temp has risen too quickly	Supply water temperature has risen too quickly.	<ul style="list-style-type: none"> • See possible causes for “Hard Lockout 4”. • Inadequate boiler water flow. • Verify that circulator is operating and that circulator and piping are sized per Section 6 of this manual.
17 Blower speed not proved	Normal waiting for blower speed to match purge and light-off setpoint.	
27 Interrupted Airflow Switch (IAS) ON	Air proving switch failed to open.	Air proving switch closed before Prepurge. <ul style="list-style-type: none"> • Failed air proving switch. Check switch for proper operation. • Short in limit string wiring
27 Interrupted Airflow Switch (IAS) OFF	Air proving switch failed to close.	Air proving switch open during Prepurge or Drive Lightoff. <ul style="list-style-type: none"> • Check for vent or combustion air pipe blockage. • Confirm air proving switch hose connected to gas valve outlet tapping and outlet tapping internal screw is open. • Loose or defective limit string wiring

12 Troubleshooting *(continued)*

G. Troubleshooting problems where a Hard Lockout Code is displayed. When a hard lockout occurs, the boiler will shut down, the display will turn red and the “Help” button will “blink”. Select the “blinking” “Help” button to determine the cause of the Hard Lockout. Once the condition that caused the lockout is corrected, the boiler will need to be manually reset using the Reset button on the “Active Fault” display or located on the Sage2.2 Control.

Alarm Output Contact

The Control includes an alarm output contact located on Control terminals J6 - 7 & 8. The alarm contact closes when the Control goes into a manual reset Hard Lockout. The list of Hard Lockouts is shown below.

Hard Lockout Codes Displayed

Lockout Number	Condition	Possible Cause
3 Burner Interlock Open (ILK OFF)	ILK safety limit input not energized	Lockout input (ILK) is not ON. Refer to Limit String Status screen for list of limits. <ul style="list-style-type: none"> Man Reset Ext. Limit device open or jumper not installed High or low gas pressure switch open or jumper not installed Thermal link open Burner door thermostat open Loose or defective limit string wiring
4 Supply high limit	Sage2.2 supply sensor detected temperatures in excess of 210°F.	<ul style="list-style-type: none"> Heating load at time of error was far below the minimum firing rate of the boiler. Defective system circulator or no flow in primary loop. Defective boiler circulator, no flow or insufficient flow in boiler loop. Control system mis-wired so that the boiler operation is permitted when no zones are calling.
6 Stack High limit	Sage2.2 Flue gas (Stack) sensor detected temperatures in excess of 204°F (95.6°C).	<ul style="list-style-type: none"> Heat exchanger needs to be cleaned. Boiler over-fired. Air-fuel mixture out of adjustment - consult factory.
12 Flame detected out of sequence	A flame signal was present when there should be no flame.	<ul style="list-style-type: none"> Defective gas valve - make sure inlet pressure is below maximum on rating plate before replacing valve.
14 Delta T Inlet/Outlet High	Temperature rise between supply and return is too high.	Inadequate boiler water flow. <ul style="list-style-type: none"> Boiler pump not operating Boiler pump undersized Valve closed
15 Return Temperature Higher Than Supply	Return temperature was greater than supply temperature for at least 75 seconds.	<ul style="list-style-type: none"> Reversed flow through boiler. Verify correct piping and circulator orientation. No boiler water flow. Verify system is purged of air and appropriate valves are open. Defective supply or return sensor
16 Supply Temperature Risen Too Quickly	Supply water temperature has risen too quickly.	<ul style="list-style-type: none"> Inadequate boiler water flow. See also causes for Hard Lockout 4. Boiler pump not operating Boiler pump undersized Valve closed
18 Light off rate proving failed	Blower is not running at Light-off rate when it should or blower speed signal not being detected by Sage2.2.	<ul style="list-style-type: none"> Loose connection in 120 VAC blower wiring. Loose or mis-wired blower speed harness. Defective blower
19 Purge rate proving failed	Blower is not running at Purge rate when it should or blower speed signal not being detected by Sage2.2.	<ul style="list-style-type: none"> Loose connection in 120 VAC blower wiring. Loose or mis-wired blower speed harness. Defective blower
20 Invalid Safety Parameters	Unacceptable Sage2.2 control Safety related parameter detected.	Parameters change was invalid. Check parameter selection and reset Control. Contact factory if problem persists.
21 Invalid Modulation Parameter	Unacceptable Sage2.2 control Modulation related parameter detected.	Reset the control.
22 Safety data verification needed	Safety related parameter change has been detected and a verification has not been completed.	Safety related Sage2.2 control parameter has been changed and verification has not been performed.
23 24 VAC voltage low/high	Sage2.2 control 24 VAC control power is high or low.	<ul style="list-style-type: none"> Loose connection in 24 VAC power wiring. Loose or mis-wired 24 VAC harness. Mis-wired wiring harness causing power supply short to ground. Defective transformer. Transformer frequency, voltage and VA do not meet specifications.

12 Troubleshooting *(continued)*

Hard Lockout Codes Displayed *(continued)*

Lockout Number	Condition	Possible Cause
24 Fuel Valve Error	Power detected at fuel valve output when fuel valve should be off.	<ul style="list-style-type: none"> Loose or defective gas valve harness. Check electrical connections. Defective gas valve (check for 24 VAC at harness during trial for ignition before replacing valve).
25 Hardware Fault	Internal control failure.	<ul style="list-style-type: none"> Reset the control. If problem reoccurs, replace the Sage.
26 Internal Fault	Internal control failure.	<ul style="list-style-type: none"> Reset the control. If problem reoccurs, replace the Sage.
27 Ignition failure	Models ALP500C, ALP600C, ALP700C and ALP800C: Flame failure after 1 try to restart.	<ul style="list-style-type: none"> No gas pressure. Gas pressure under minimum value shown on rating plate. Gas line not completely purged of air. Defective Electrode. Loose burner ground connection. Defective Ignition Cable. Defective gas valve (check for 24 VAC at harness during trial for ignition before replacing valve). Air-fuel mixture out of adjustment - consult factory.
27 Interrupted Airflow Switch (IAS) ON	Air proving switch failed to open.	<ul style="list-style-type: none"> Air proving switch closed before Prepurge. Failed air proving switch. Check switch for proper operation. Short in limit string wiring
27 Interrupted Airflow Switch (IAS) OFF	Air proving switch failed to close.	<ul style="list-style-type: none"> Air proving switch open during Prepurge or Drive Lightoff. Check for vent or combustion air pipe blockage. Confirm air proving switch hose connected to gas valve outlet tapping and outlet tapping internal screw is open. Loose or defective limit string wiring
42 AC Phase Fault	AC inputs phase reversed	<ul style="list-style-type: none"> Check control and display connections. Verify line voltage frequency and voltage meet specifications. Verify 24 VAC transformer functioning properly.
47 Flame Lost	Flame lost at some stage. See display for details.	<ul style="list-style-type: none"> Gas pressure too low. See minimum on boiler rating label. Air-fuel mixture out of adjustment. See System Start-Up Section. Disconnected or defective flame sensor wire. Defective flame sensor. Defective gas valve. Before replacing valve, check for 24 VAC at gas valve connector during trial for ignition.
284 Memory Reset To Default	OEM Memory Lost, Honeywell Default Memory Restored	<ul style="list-style-type: none"> Control failure Consult factory Replace control

13 Service Parts

All Alpine Service Parts may be obtained through your local authorized U.S. Boiler Company representatives or outlets. Should you require assistance in locating a U.S. Boiler Company representative or outlet in your area, or have questions regarding the availability of U.S. Boiler Company products or repair parts, please contact U.S. Boiler Company Customer Service at (717) 481-8400 or Fax (717) 481-8408.

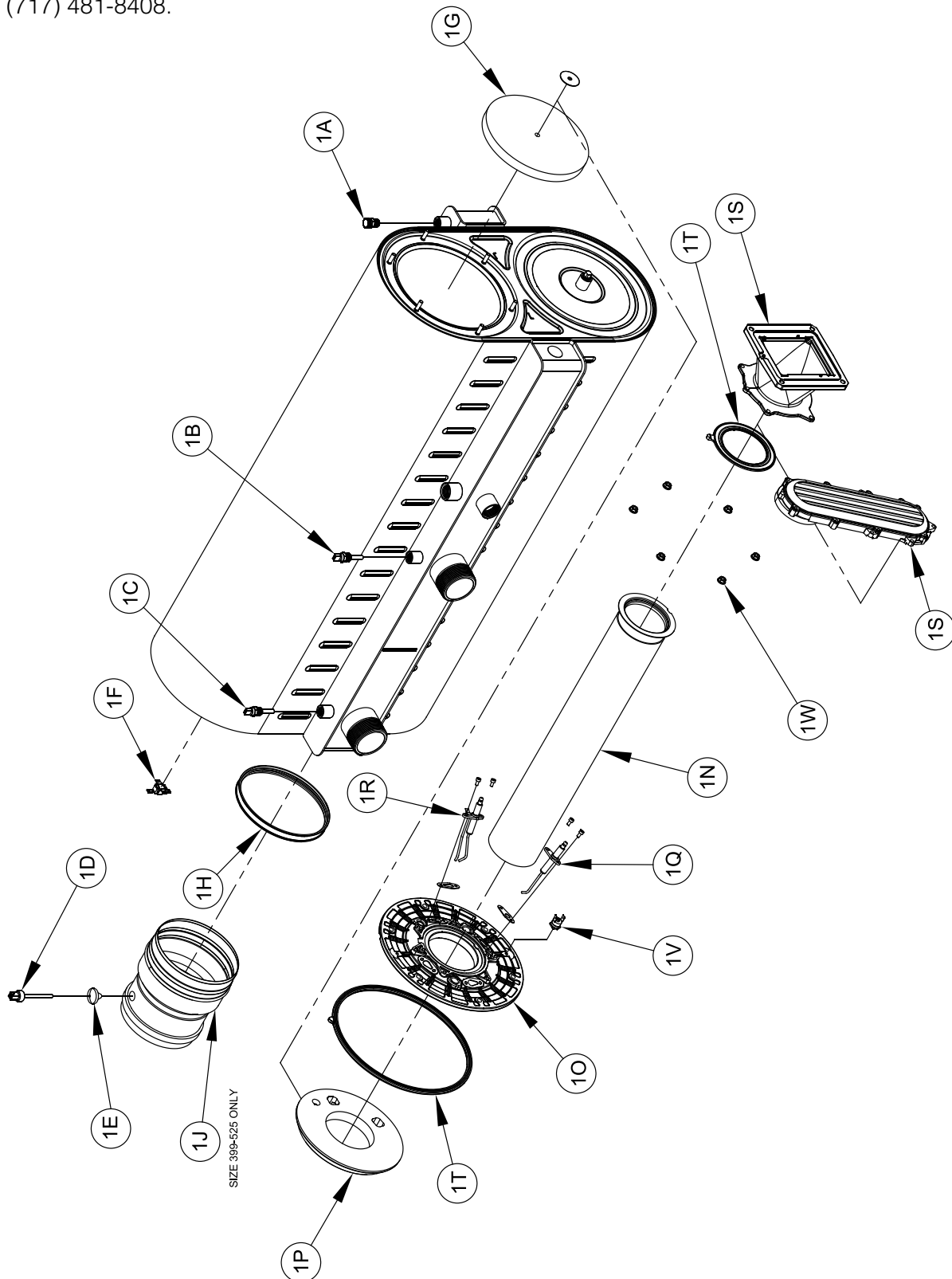

13 Service Parts *(continued)*

Heat Exchanger Components						
Key No.	Description	Part Number				
		ALP399C	ALP500C	ALP600C	ALP700C	ALP800C
-	Replacement Heat Exchanger Assembly (includes bare heat exchanger, supply and return water temperature sensors, air vent valve and header gaskets)	109102-01	109103-01	109104-01		109105-01
1A	Air Vent Valve	108760-01				
1B	Supply Water Temperature Sensor / High Limit Sensor	109202-01				
1C	Return Water Temperature Sensor	107503-01				
1D	Flue Temperature Sensor and Grommet	109109-01				
1E	Flue Sensor Grommet	105997-01				
1F	Replacement Thermal Link and Rear Insulation Disc Kit (includes thermal link, disc, hardware, and instructions)	104998-01				
1G	Replacement Rear Insulation Disc Kit (includes disc, hardware, and instructions)	105651-01				
1H	Flue Exit Gasket Replacement Kit (includes gasket and dielectric grease)	104501-01		104502-01		
1J	4 in. Flue Collar Adapter	109203-01		N/A		
1K	Temperature and Pressure Gauge (not shown)	105894-01		103470-02		
1L	Safety Relief Valve (not shown)	50 PSI: 109039-01		60 PSI: 81660375		
	Alternate Safety Relief Valve Kit (not shown, includes safety relief valve and temperature and pressure gauge)	80 PSI: 104200-01 100 PSI: 104201-01				
1M	Boiler Drain Valve, 3/4 in. NPT (not shown)	108709-01				

Burner Components						
Key No.	Description	Part Number				
		ALP399C	ALP500C	ALP600C	ALP700C	ALP800C
1N	Replacement Burner Kit (includes burner, burner gasket, and hardware)	104988-01	104990-01			104991-01
1O	Replacement Burner Door Kit (includes door with inner and outer seals, gaskets for sensor and igniter, insulation, and thermostat; does not include igniter or flame sensor)	104992-01	104993-01			
1P	Burner Door Insulation Kit (WARNING! : Contains RCF)	105650-01	105674-01			
1Q	Replacement Flame Sensor Kit (includes sensor, gasket, and hardware)	103339-01	103310-01			
1R	Replacement Igniter Kit (includes igniter, gasket, and hardware)	103005-01	103308-01			
1S	Replacement Gas/Air Duct Kit (includes duct, gaskets, and hardware)	104994-01	106510-01	104996-01		
1T	Burner Gasket and Outer Seal	107500-01	109219-01			
1V	Burner Door Thermostat with Manual Reset	107413-01				
1W	Burner Door Hex Flange Nut, M6 x 1.0 mm (6 per boiler)	101724-01				

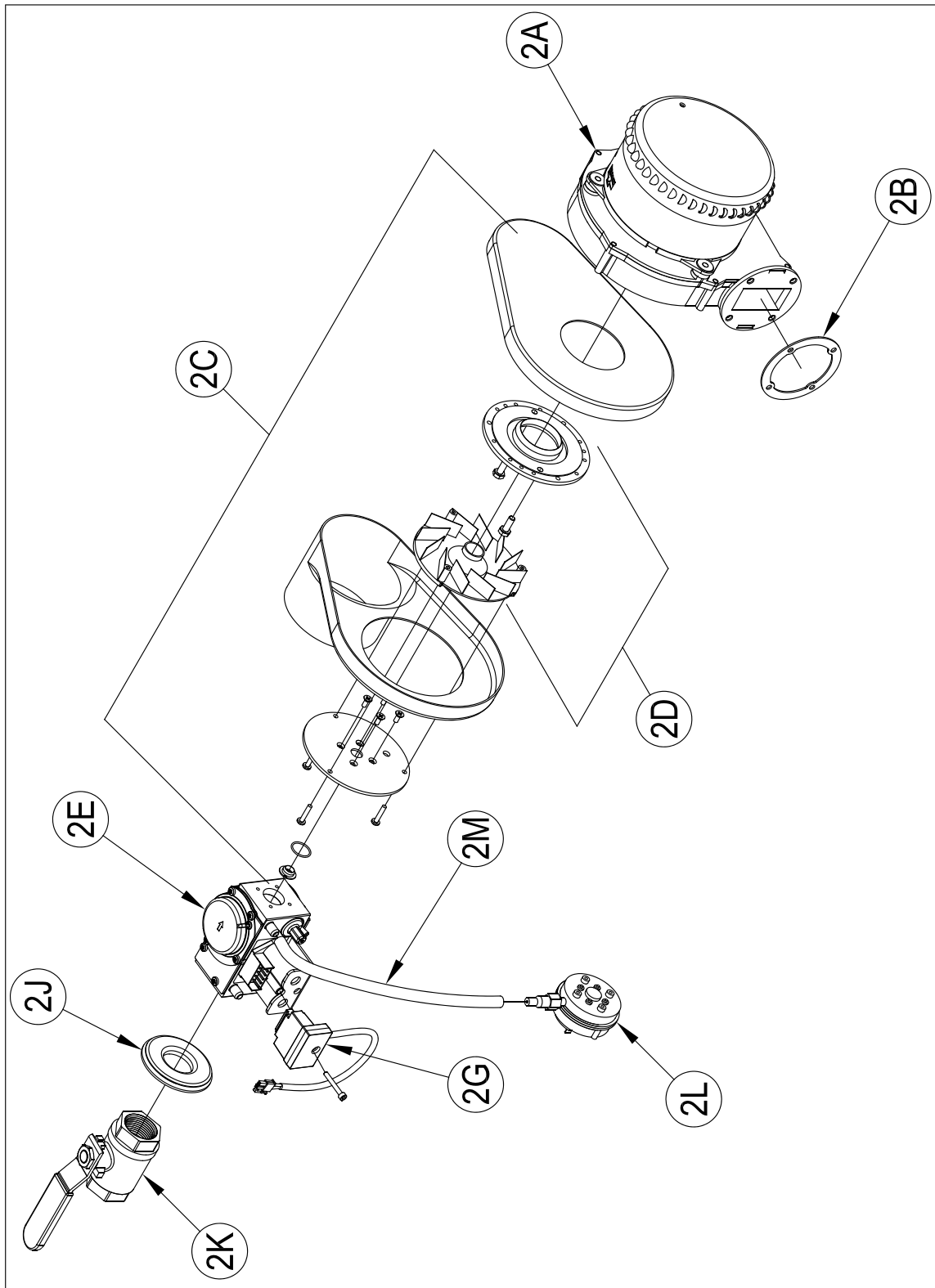
13 Service Parts *(continued)*

13 Service Parts *(continued)*

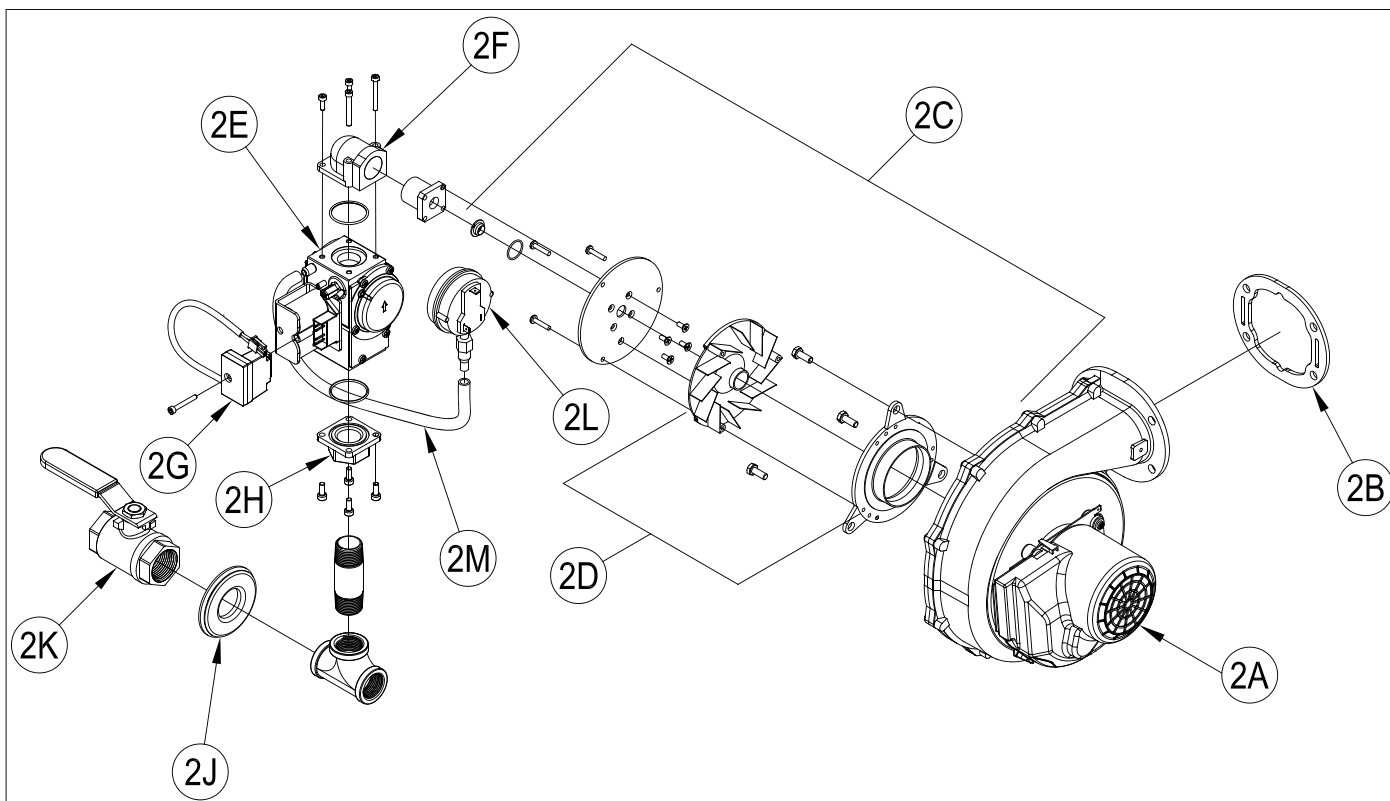

Blower / Gas Train Components			
Key No.	Description	Part Number	
		ALP399C	ALP500C
2A	Replacement Blower Kit (includes blower, blower outlet gasket and hardware)	104999-01	109207-01
2B	Blower Outlet Gasket	106209-01	109208-01
2C	Blower Inlet Assembly (includes gas orifice, injector flange, inlet shroud (425C only), swirl plate, blower adapter plate, and mounting hardware)	110037-01	110038-01
2D	Blower Inlet Replacement Kit (includes swirl plate, blower adapter plate, and mounting hardware)	104620-04	104620-05
2E	Replacement Gas Valve Kit (includes one gas valve and o-rings)	105004-01	105004-04
2F	Gas Valve 90° Flange Kit (includes one 90° flange, o-ring, and hardware)	N/A	108103-01
2G	Gas Valve Wire Harness (includes harness with plug and M4 x 30 mm screw)	102971-01	
2H	Gas Valve Straight Flange Kit (includes one straight flange, o-ring, and hardware)	N/A	108104-01
2J	Gas Line Rubber Grommet	3/4 in. NPT: 108889-01	
2K	Gas Shutoff Valve	3/4 in. NPT: 101615-01	
2L	Air Proving Switch	109108-01	109113-01
2M	Air Proving Switch Tubing, silicone, 5/16 in. ID x 0.07 in. Wall Thickness x 18 in. long	109116-01	

13 Service Parts (continued)

ALP600C, ALP700C and ALP800C
(ALP800C shown)

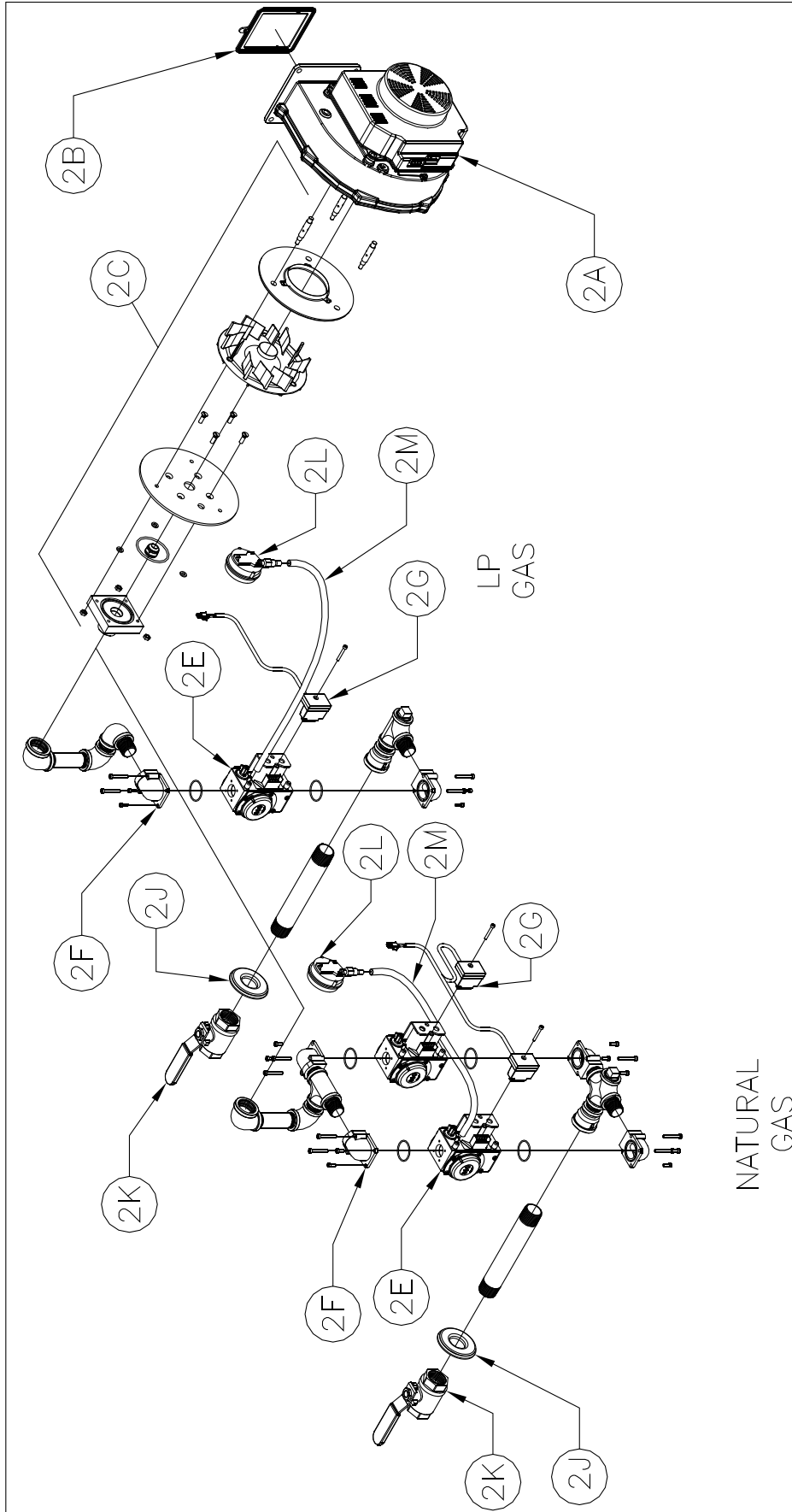

13 Service Parts *(continued)*

Blower / Gas Train Components				
Key No.	Description	Part Number		
		ALP600C	ALP700C	ALP800C
2A	Replacement Blower Kit (includes blower, blower outlet gasket and hardware)	104999-03		
2B	Blower Outlet Gasket	109223-01		
2C	Blower Inlet Assembly (includes gas orifice, injector flange, inlet shroud (425 only), swirl plate, blower adapter plate, and mounting hardware)	Natural Gas: 110041-01	Natural Gas: 110042-01	110043-01
		LP Gas: 110039-01	LP Gas: 110040-01	
2D	Blower Inlet Replacement Kit (includes swirl plate, blower adapter plate, and mounting hardware)	N/A		
2E	Replacement Gas Valve Kit (includes one gas valve and o-rings)	Natural Gas: 105004-04		
		LP Gas: 105004-03		
2F	Gas Valve 90° Flange Kit (includes one 90° flange, o-ring, and hardware)	108103-01		
2G	Gas Valve Wire Harness (includes harness with plug and M4 x 30 mm screw)	Natural Gas: 103225-01		
		LP Gas: 103300-01		
2H	Gas Valve Straight Flange Kit (includes one straight flange, o-ring, and hardware)	N/A		
2J	Gas Line Rubber Grommet	1 in. NPT: 109226-01		
2K	Gas Shutoff Valve	1 in. NPT: 816SOL0015		
2L	Air Proving Switch	109114-01	109115-01	
2M	Air Proving Switch Tubing, silicone, 5/16 in. ID x 0.07 in. Wall Thickness x 18 in. long	109116-01		

13 Service Parts *(continued)*

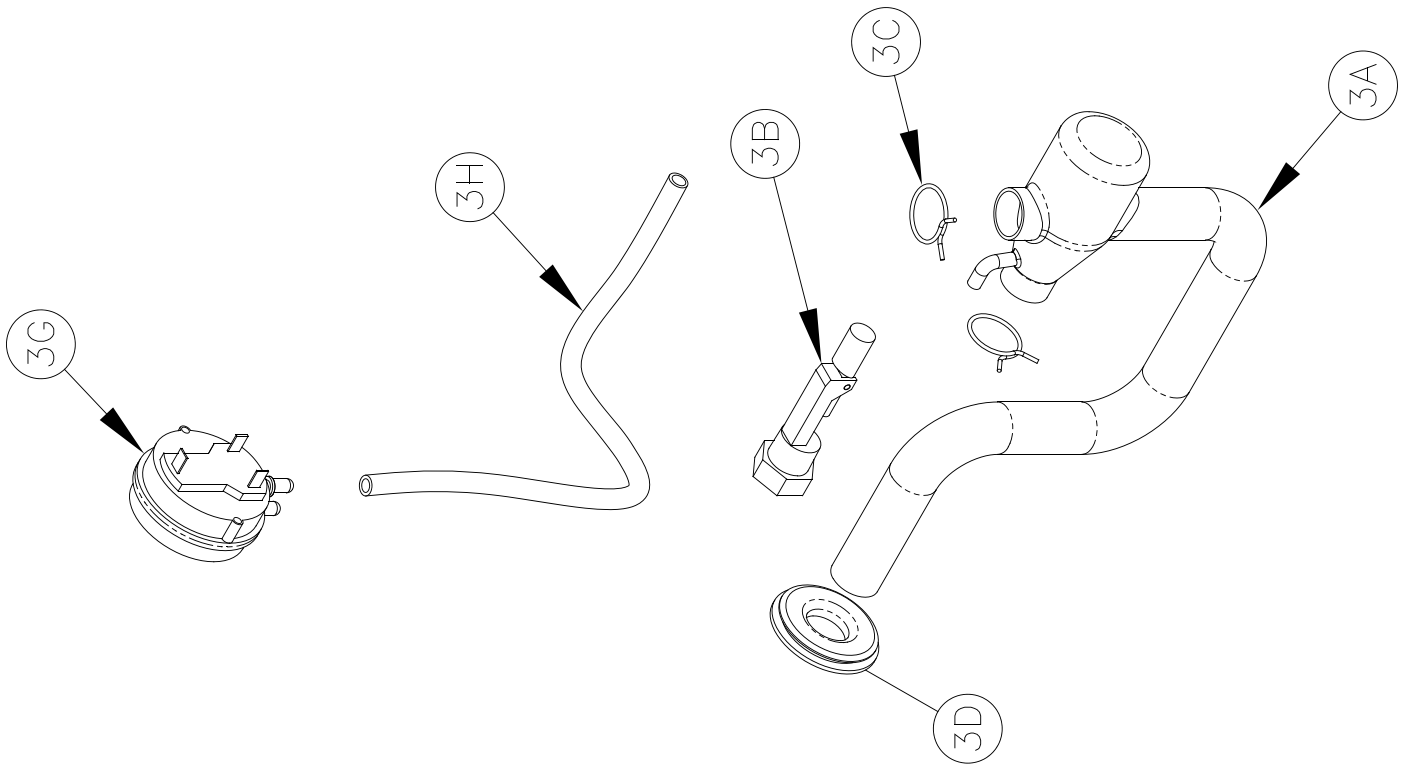

Condensate Trap and Related Components						
Key No.	Description	Part Number				
		ALP399C	ALP500C	ALP600C	ALP700C	ALP800C
3A	Replacement Condensate Trap Kit (includes trap, float switch, grommet, coupling, and clamps)	109111-01	110044-01			
3B	Replacement Condensate Float Switch Kit (includes float switch and clamp)		105005-01			
3C	Spring Hose Clamp, 15/16 in. OD hose		110046-01			
3D	Rubber Grommet, Condensate Trap		110047-01			
3E	Condensate Neutralizer Kit (not shown, includes limestone chips)		101867-01			
3F	Limestone Chips, 2 lb. bag (not shown)		101873-01			
3G	Sump Pressure Switch	108893-01	106988-02		109228-01	
3H	Air Pressure Switch Tubing, Silicone, 3/16 in. ID x 0.07 in. Wall Thickness		109116-01			

13 Service Parts *(continued)*

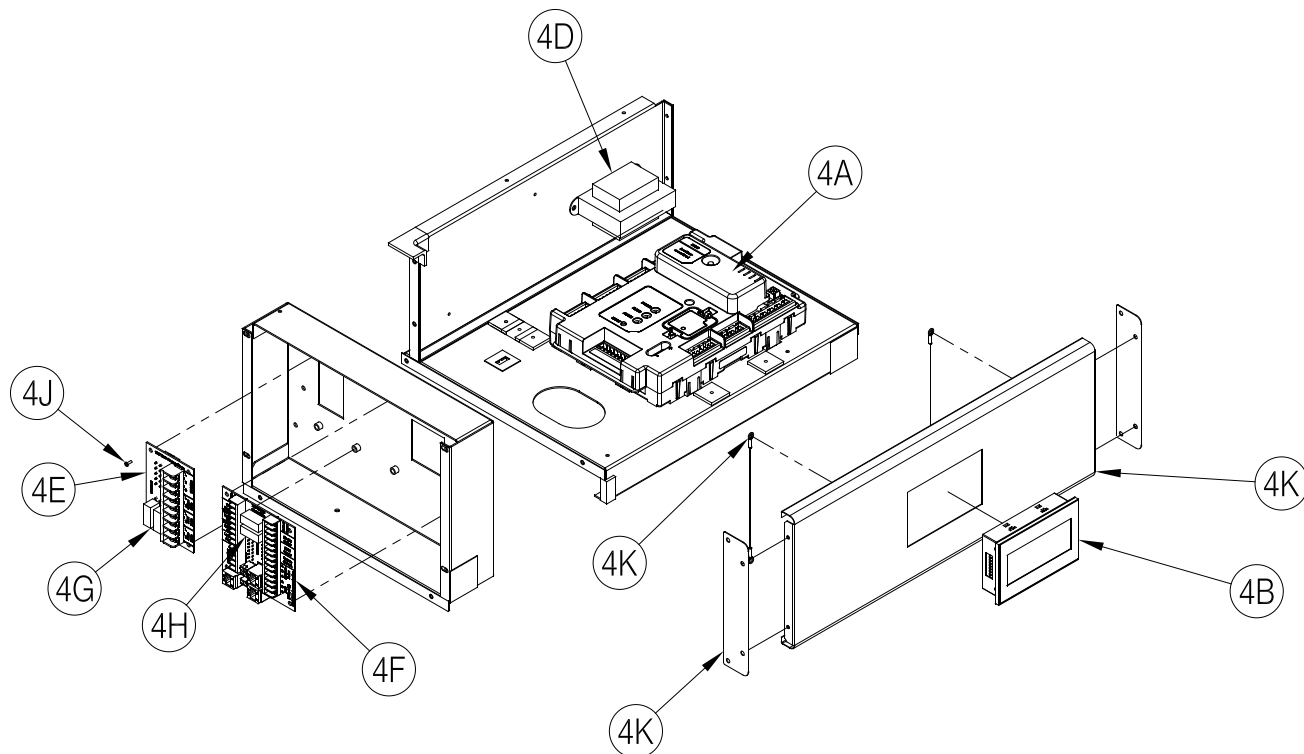

Control Components						
Key No.	Description	Part Number				
		ALP399C	ALP500C	ALP600C	ALP700C	ALP800C
4A	Replacement Control Kit (programmed)	106498-01	106498-02			
4B	Replacement Display Kit (programmed, includes mounting hardware)	106508-01				
4D	Transformer	106034-01	109220-01			
4E	Replacement 120V PCB Kit (includes PCB, fuses, and hardware)	106512-01				
4F	Replacement Low Voltage PCB Kit (includes PCB, fuses, and hardware)	106513-01				
4G	Pump Fuse, 5x20 mm, 6.3A Slow Blow	109155-01				
4H	24V Fuse, 5x20 mm	1.6A, Slow-Blow 109156-01		2.0A, Fast-Acting 109157-01		
4J	Machine Screw, 8-32 x 1/2 in.	101033-01				
4K	Display Panel Assembly	109204-01				

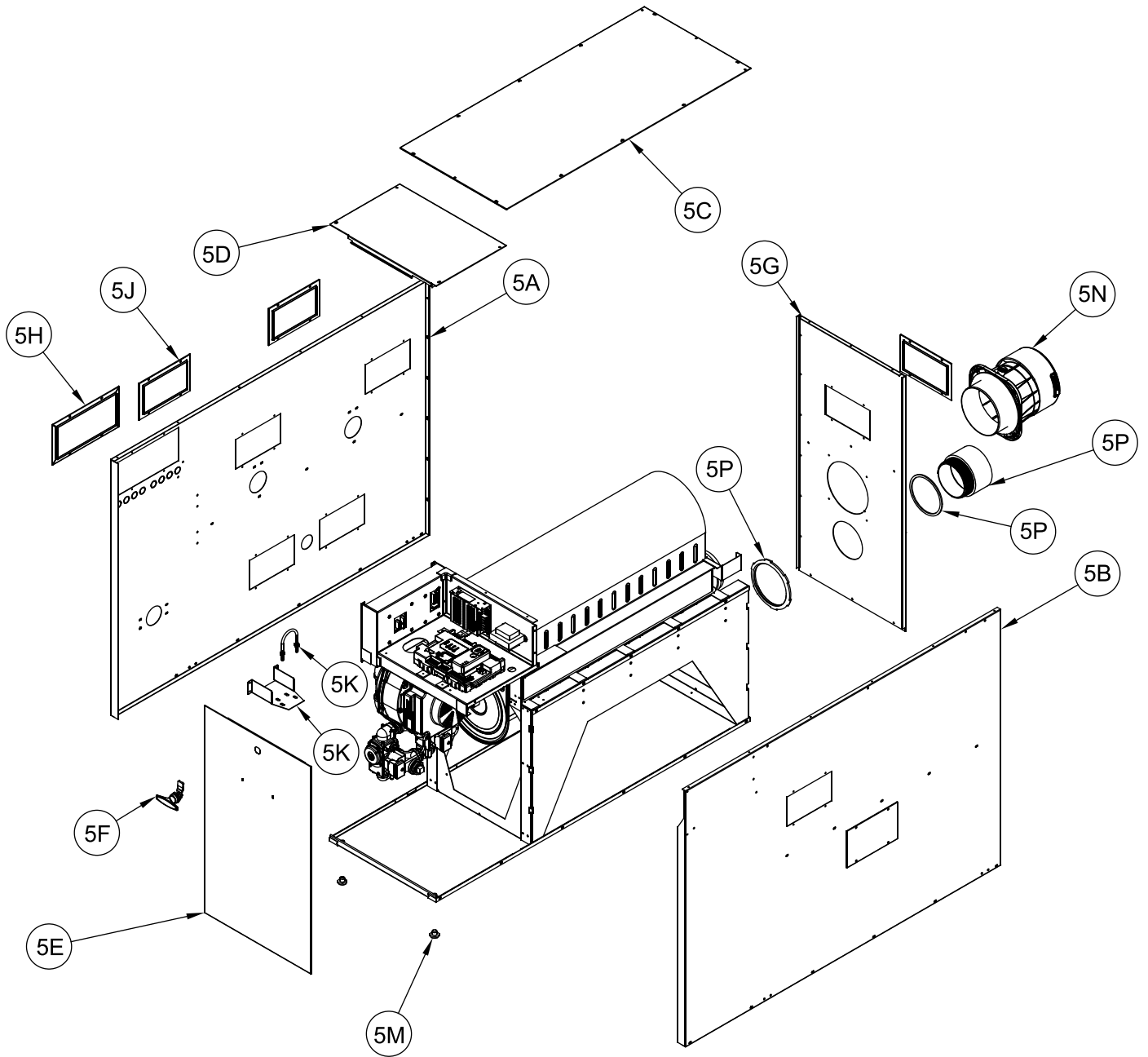
13 Service Parts *(continued)*

13 Service Parts *(continued)*

Jacket and Trim Components					
Key No.	Description	Part Number			
		ALP399C	ALP500C	ALP600C	ALP700C
5A	Left Side Panel	106249-01	106249-02	106249-03	106249-04
5B	Right Side Panel (includes rating label instructions)	106517-01	106517-02	106517-03	106517-04
5C	Top Panel (includes gaskets)	106254-01	106254-02	106254-03	106254-04
5D	Top Control Access Panel (includes label)	106518-01			
5E	Front Door (includes gaskets and labels)	106600-01	106600-02		
5F	Replacement Door Latch Kit (includes latch, cam, and hardware)	106509-01			
5G	Rear Panel (includes gaskets)	106253-01	106253-02	106253-03	
5H	Junction Box Access Panel, 5.5 in. x 10.5 in.	109175-01			
5J	Access Panel, 5 in. x 8 in. (includes gasket)	109176-01			
5K	Gas Train Support Bracket (includes U-bolt)	109185-01	109187-01	109188-01	
5M	Nylon Glide Replacement Kit	105014-01			
5N	Vent Connector for CPVC/PP/SS (includes jacket gasket and vent pipe gaskets)	4 in. (100 or 110 mm) 108866-01		6 in. (150 or 160 mm) 109227-01	
5P	Combustion Air Connector, 4 in. PVC Adapter (includes gasket and locknut)	109189-01			

13 Service Parts *(continued)*

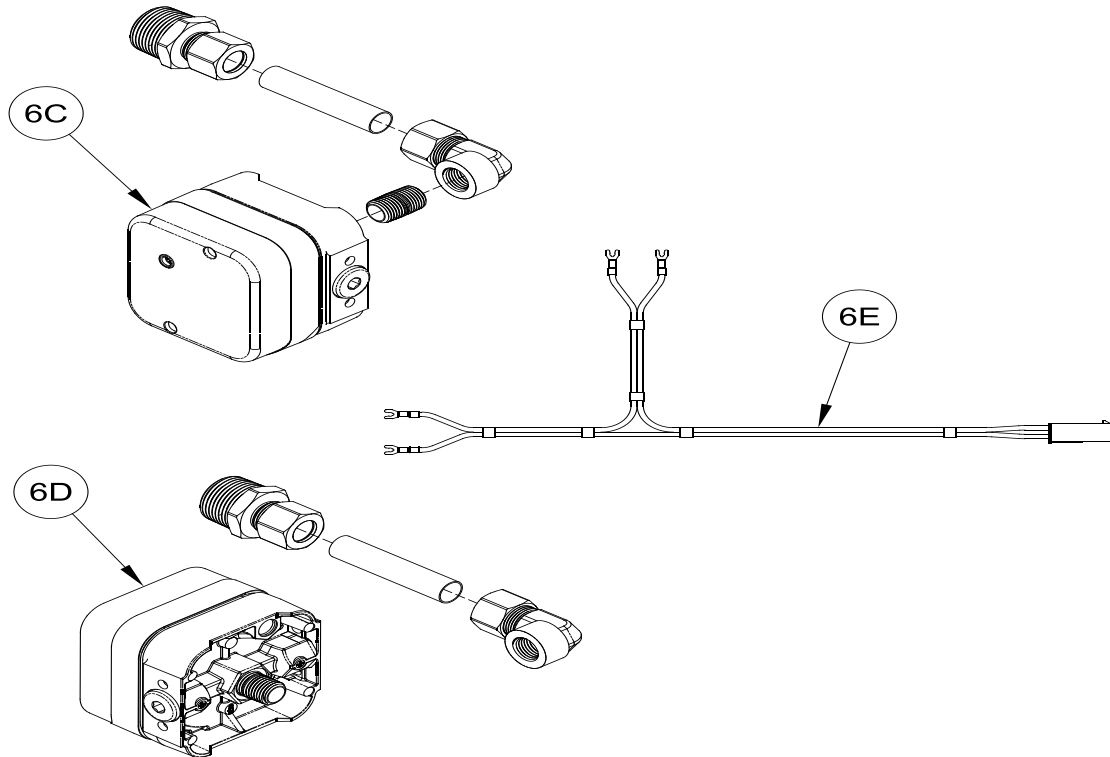

Additional Components						
Key No.	Description	Part Number				
		ALP399C	ALP500C	ALP600C	ALP700C	ALP800C
6A	CSD-1 Kit (not shown, 106056-01 includes man. reset high limit and immersion well; 107421-01 kit includes gas pressure switches) Contact U.S. Boiler Company for LP boilers.	106056-01		107421-01		
6B	Gas Pressure Switch Assembly	N/A		109205-01		
6C	Low Gas Pressure Switch	N/A		109191-01		
6D	High Gas Pressure Switch	N/A		109190-01		
6E	Gas Pressure Switch Wire Harness	N/A		109194-01		
6F	Flow Switch Kit (not shown, includes switch and paddles)			109195-01		
6G	Flow Switch Repair Paddle Kit (not shown, includes paddles and hardware)			110077-01		
6H	Outdoor Temperature Sensor (not shown)			108681-01		
6J	Header Sensor or DHW Sensor for Direct Immersion, 1/2 in. NPT (not shown)			109196-01		
6K	Header Sensor or DHW Sensor for Immersion Well Installation (not shown)			103104-01		
6L	Immersion Well, 1/2 in. NPT			108853-01		
6M	30 in. Long Schedule 40 CPVC Pipe (not shown)	4 in. 102193-02			6 in. 103267-01	
6N	Schedule 80 CPVC 90° Elbow (not shown)	4 in. 102192-02			6 in. 103268-01	
6O	Vent / Combustion Air Screen (not shown)	4 in. 102191-02			6 in. 102191-03	

13 Service Parts *(continued)*

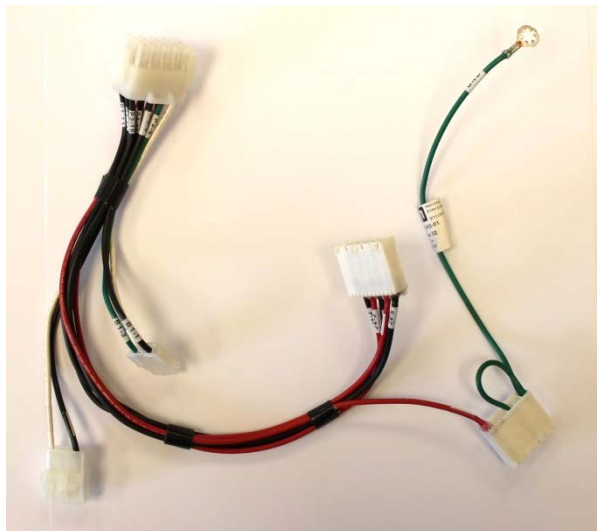

10A



10D

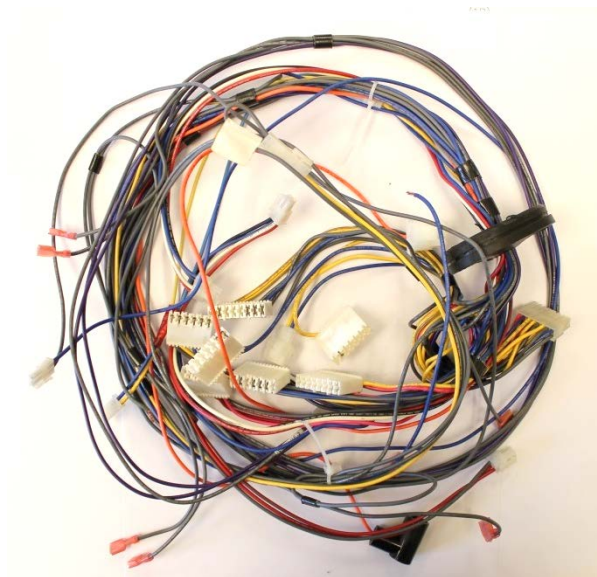

10B



10G



10C

13 Service Parts *(continued)*

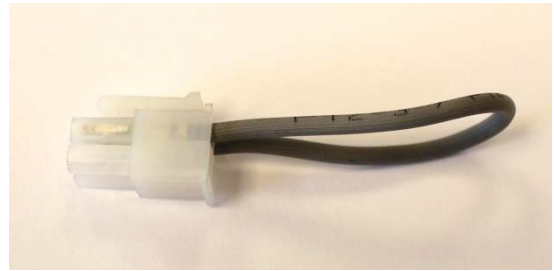
**10H****10J**

Wiring Harnesses					
Key No.	Description	Part Number			
		ALP399C	ALP500C	ALP600C	ALP700C
10A	120V Harness	109193-01			
10B	Low Voltage Harness	109201-01			
10C	Fan Power Harness	109198-01			
10D	Ignition Harness	109192-01			
10G	GT02 Display Communication Harness	109200-01			
10H	Flow Switch Harness	109199-01			
10J	LWCO Jumper	105908-01			

Appendix A Instructions for High Altitude Installation Above 2,000 ft.

⚠ WARNING

If installing ALP500C or ALP700C: Do not convert ALP500C to LP gas (propane) at altitudes above 6,000 ft. Also, do not install ALP700C LP gas (propane) at altitudes above 7,800 ft. Attempts to do so may result in unreliable operation, property damage, personal injury or death due to carbon monoxide (CO air free) poisoning.

These instructions apply only to the following Alpine boiler configurations: **2,001 ft.- 4,500 ft., 4,501 ft.- 6,000 ft., 6,001 ft.- 7,800 ft., 7,801 ft. - 10,000 ft.**

These instructions contain specific instructions to properly set up your boiler to ensure proper operation.

⚠ WARNING

LP Conversions - Alpine boiler setup from factory is configured for use with natural gas installed from 0 - 2,000 ft. above sea level only. For ALP399C or ALP500C conversion to LP at altitude above 2,000 ft., follow these instructions as specific instructions must be followed when converting for use with LP. If the information in these instructions is not followed exactly, a fire, an explosion or production of carbon monoxide may result causing property damage, personal injury or death. The qualified service agency is responsible for proper installation of this boiler for use with LP gas. The installation is not proper and complete until the operation of the converted appliance is checked as specified in the manufacturer's instructions supplied. ALP600C, ALP700C and ALP800C are factory shipped as either natural gas build or LP gas build. Field conversions of ALP600C, ALP700C and ALP800C are not permitted.

⚠ DANGER

These instructions include a procedure for adjusting the air-fuel mixture on this boiler. This procedure requires a combustion analyzer to measure the CO₂ (or Oxygen) and Carbon Monoxide (CO air free) levels in flue gas. Adjusting the air-fuel mixture without a proper combustion analyzer could result in unreliable boiler operation, personal injury, or death due to carbon monoxide poisoning.

⚠ WARNING

Failure to set up the Boiler in accordance with these instructions could result in high amount of Carbon Monoxide to be produced which could result in death, serious injury, and/or reduced component life.

Adjusting Boiler Type (must be completed first)

Select the correct Alpine boiler size and altitude range using the touch screen display as follows:

1. Check boiler's label for actual boiler size.
2. Confirm installation altitude .
3. Power up the boiler. Display will show the Home screen.
4. Press "Adjust" button on Home screen.
5. Press "Adjust" button on Adjust Mode screen.
6. Press "Login" button to access Password screen.

7. Press 5-digit display to open keypad. Enter password "086" and press return arrow to close keypad. Press "Save" button.
8. Press "Adjust" button to enter Adjustment Mode.
9. Press "Modulation Setup" button.
10. Press "Adjust" button on Boiler Type screen.
11. Use the ↓ ↑ arrows to select the correct size and altitude of your boiler. Press the  button to enter your selection. See Figure A-1.
12. Press "Enter" button until display stops blinking. Press "Next" and repeat until "Completed" is displayed.
13. Press "☒" to exit.

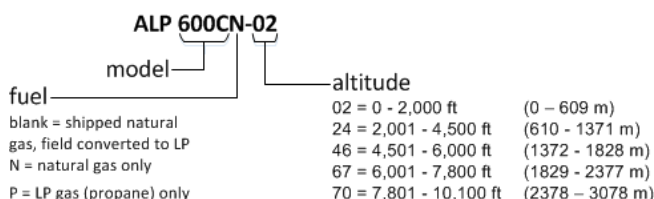

Figure A-1: Boiler Model (Boiler Type) Decoding

Appendix A Instructions for High Altitude Installation Above 2,000 ft.

(continued)

Start-up Instructions for Natural Gas or LP

1. Confirm Alpine boiler size, type and installed altitude prior to startup.
2. ALP399C or ALP500C LP conversion only: Adjust throttle screw to preliminary setting per Table A-2.
3. Start boiler as described in boiler Installation manual and lock boiler in high fire (See Section 9 System Start-up). If boiler does not light, turn throttle screw in 1/4 turn increments in a counterclockwise direction until boiler fires. Do not stop here, follow Steps 4-7.
4. Verify CO₂ is within range shown in Table A-4 and CO air free is less than 200 ppm. If CO₂ and CO air free are within these limits, move to Step 6 and check fan speed at high fire operation only.
5. If CO₂ is outside the window outlined in Table A-4, adjust throttle screw such that the CO₂ falls in this range while boiler is locked manually in high fire. Turning throttle screw counter-clockwise increases the CO₂, while clockwise rotation leans the mixture, reducing the CO₂. Once CO₂ is within the limits in Table A-4, check CO air free again to ensure it is below 200 ppm. If CO air free is above 200 ppm turn throttle screw clockwise in 1/4 increments until CO air free is below 200 ppm, while ensuring CO₂ remains in the range specified in Table A-4. If CO air free is still above 200 ppm, reduce fan speed in 100 rpm increments until CO air free is less than 200 ppm.
8. If low fire CO₂ is too low, increase CO₂ by turning offset screw clockwise in less than 1/8 turn increments and checking the CO₂ and CO air free after each adjustment. If boiler is equipped with 2 gas valves, offset screw adjustments must be done to both gas valves equally and simultaneously. See Figure A-3 for location of offset screw. Verify CO air free is less than 200 ppm.
9. Start boiler five times at the above settings to ensure boiler lights off without delay and without noise. Check CO₂ and CO air free to ensure that the CO₂ is within the range specified in Table A-4 and CO air free is below 200 ppm. Be sure to replace the screw cap in the vent adapter when combustion testing is complete.
10. Verify that the gas inlet pressure is between the following limits with all gas appliances (including the converted boiler) both on and off:
 - Natural Gas: 4.0 - 14.0 inches w.c.
 - LP Gas: 8.0 - 14.0 inches w.c.

If inlet pressure is not within limits, adjust before performing high altitude setup procedure.
11. Return boiler to Automatic Mode. Press "Auto".

WARNING

Asphyxiation Hazard. Offset screw is adjusted at the factory. DO NOT touch the offset screw if measured low fire CO₂ is within limits specified in Table A-4.

6. Lock boiler in low fire (see Section 9. System Start-up). Verify CO₂ is within range shown in Table A-4 and CO air free is less than 200 ppm.
7. If low CO₂ is too high, decrease CO₂ by turning offset screw counter-clockwise in less than 1/8 turn increments and checking the CO₂ and CO air free after each adjustment. If boiler is equipped with 2 gas valves, offset screw adjustments must be done to both gas valves equally and simultaneously. See Figure A-3 for location of offset screw. Verify CO air free is less than 200 ppm.

Table A-2: Approximate Clockwise Throttle Screw Turns for LP Gas (Propane) Conversion

Boiler Model	Approximate Throttle Screw Turns
ALP399C	2 3/4
ALP500C	3
ALP600C	N/A - Factory LP Builds
ALP700C	
ALP800C	

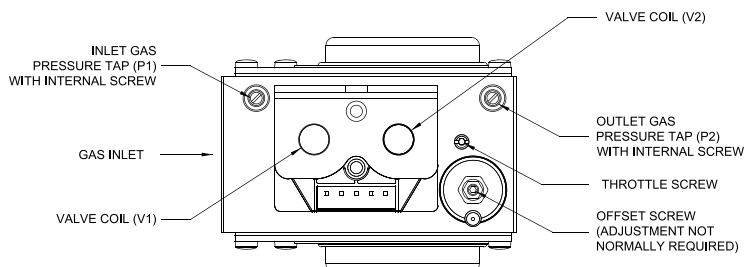

Figure A-3: Gas Valve Detail

Appendix A Instructions for High Altitude Installation Above 2,000 ft.

(continued)

Table A-4: Alpine Altitude Adjustments

Altitude	Model	Fuel	Recommended CO ₂ Range	Percentage Derate (approx. per 1,000 ft.)
2,001 ft. to 4,500 ft.	ALP399C	NG	8.6-9.2	2.3%
		LP	9.4-10.2	
	ALP500C	NG	8.7-9.2	4.1%
		LP	9.8-10.1	
	ALP600C	NG	8.6-9.2	0.0%
		LP	9.4-9.9	
	ALP700C	NG	8.2-8.7	1.7%
		LP	9.2-9.7	
	ALP800C	NG	8.2-9.1	1.2%
		LP	9.4-10.0	0.0%
4,001 ft. to 6,000 ft.	ALP399C	NG	8.6-9.2	2.3%
		LP	9.4-10.2	
	ALP500C	NG	8.7-9.2	4.1%
		LP	9.8-10.1	
	ALP600C	NG	8.6-9.2	0.0%
		LP	9.4-9.9	
	ALP700C	NG	8.2-8.7	0.0%
		LP	9.2-9.7	
	ALP800C	NG	8.2-9.1	1.2%
		LP	9.4-10.0	0.0%
6,001 ft. to 7,800 ft.	ALP399C	NG	8.6-9.2	2.2%
		LP	9.4-10.0	
	ALP500C	NG	8.7-9.2	3.6%
		LP	No Application	No Application
	ALP600C	NG	8.6-9.2	0.7%
		LP	9.4-9.7	1.2%
	ALP700C	NG	8.2-8.7	0.8%
		LP	9.2-9.5	
	ALP800C	NG	No Application	No Application
		LP	9.4-9.8	1.4%
7,801 ft. to 10,100 ft.	ALP399C	NG	8.6-9.2	2.2%
		LP	9.4-9.8	
	ALP500C	NG	8.7-9.2	3.4%
		LP	No Application	No Application
	ALP600C	NG	8.6-9.2	2.0%
		LP	9.4-9.8	
	ALP700C	NG	8.2-8.7	2.0%
		LP	No Application	No Application
	ALP800C	NG	No Application	No Application
		LP	9.4-9.7	2.8%

NOTE: De-rate's per 1,000 ft. are approximate

Based on minimum vent length

Appendix B Figures

Figure Number	Page Number	Description
Section 1 - Product Description, Specifications & Dimensional Data		
Figure 1-1	5	Alpine - Model ALP399C
Figure 1-2	6	Alpine - Model ALP500C
Figure 1-3	7	Alpine - Models ALP600C and ALP700C
Section 3 - Pre-Installation and Boiler Mounting		
Figure 3-3	11	Clearances To Combustible and Non-combustible Material
Figure 3-5	13	Boiler Stacking
Section 4 - Venting		
Figure 4-5	17	Location of Vent Terminal Relative to Windows, Doors, Grades, Overhangs, Meters and Forced Air Inlets - Two-Pipe System Vent Terminal (Shown), Two-Pipe System Air Intake Terminal (Not Shown)
Figure 4-6	18	Direct Vent - Sidewall Standard Terminations
Figure 4-7	19	Direct Vent - Sidewall Snorkel Terminations
Figure 4-8	19	Direct Vent - Sidewall Low Profile Termination
Figure 4-9	20	Direct Vent - Vertical Terminations
Figure 4-10	20	Direct Vent - Vertical Terminations w/ Sloped Roof
Figure 4-15	23	Field Installation CPVC/PP/SS Vent Connector
Figure 4-16	23	Near-Boiler Vent/Combustion Air Piping
Figure 4-18	24	CPVC/PVC Expansion Loop and Offset
Figure 4-19	24	Wall Penetration Clearances for PVC Vent Pipe
Figure 4-20	25	Screen Installation
Figure 4-25	30	Field Installation of Polypropylene Vent Adapter
Figure 4-26	30	Field Installation of Polypropylene Combustion Air Adapter
Figure 4-27	30	Locking Band Clamp Installation, M&G DuraVent or Centrotherm InnoFlue
Figure 4-28	30	Alternate Locking Band Clamp Installation, M&G DuraVent
Figure 4-29	31	Flexible Vent in Masonry Chimney with Separate Combustion Air Intake
Figure 4-33	33	Field Installation of Stainless Steel Vent Adapter
Figure 4-34	38	Multiple Boiler Direct Vent Termination
Section 5 - Condensate Disposal		
Figure 5-2	40	Condensate Trap and Drain Line
Section 6 - Water Piping and Trim		
Figure 6-2	41	Factory Supplied Piping & Trim Installation - ALP399C
Figure 6-6	44	Factory Supplied Piping & Trim Installation - ALP500C, ALP600C, ALP700C and ALP800C
Figure 6-7	45	Boiler Head Loss
Figure 6-9	47	Near Boiler Piping - Heating Only
Figure 6-10	48	Near Boiler Piping - Heating Plus Indirect Water Heater

Appendix B Figures *(continued)*

Figure Number	Page Number	Description
Section 6 - Water Piping and Trim (continued)		
Figure 6-12	49	Isolation of the Boiler From Oxygenated Water with A Plate Heat Exchanger (IWH Piped as Part of Boiler Piping)
Figure 6-13	50	Isolation of the Boiler From Oxygenated Water with A Plate Heat Exchanger (IWH Piped Off System Header)
Figure 6-14	50	Recommended Direct Immersion Header Sensor Installation Detail
Figure 6-15	50	Alternate "Immersion" Type Header Sensor Installation Detail
Figure 6-16	51 & 52	Multiple Boiler Water Piping w/Domestic Hot Water Heater (Page 1 of 2)
Section 7 - Gas Piping		
Figure 7-5	53	Recommended Gas Piping
Figure 7-7	55	Gas Inlet Pressure Tap and Pressure Switch Location
Section 8 - Electrical		
Figure 8-2	59	PCB Locations for Field Wiring
Figure 8-3	59	120 VAC Field Wiring
Figure 8-4	60	Low Voltage Field Wiring
Figure 8-5	61	Ladder Diagram
Figure 8-6	62	Wiring Connections Diagram
Figure 8-7	63	Modified Wiring For DHW Priority When Using Low Flow Circulator Piped Off System Header - Heating (with Central Heating Circulators) Plus Alternately Piped Indirect Water Heater
Figure 8-8	64	Modified Wiring For DHW Priority When Using Low Flow Circulator Piped Off System Header - Heating (with Central Heating Zone Valves) Plus Alternately Piped Indirect Water Heater
Figure 8-9	65	Multiple Boiler Wiring Diagram, Internal Multiple Boiler Control Sequencer (Two Boilers Shown, Typical Connections for up to Eight Boilers)
Figure 8-10	66	Boiler-to-Boiler Communication (with Zone Control Circulator Panel)
Figure 8-11	67	Multiple Boiler Wiring Diagram w/Tekmar 265 Control
Figure 8-12	68	Multiple Boiler Wiring Diagram w/Tekmar 264 Control
Section 9- System Start-Up		
Figure 9-1	71	Operating Instructions
Figure 9-4	73	Burner Flame
Figure 9-5	73	Gas Valve Detail
Section 10 - Operation		
Figure 10-4	84	Home Screen Details
Figure 10-5	84	Screen Navigation
Figure 10-6	85	Status Screen Overview
Figure 10-7	85	Boiler Status Screen Definitions
Figure 10-8	89	Adjust Mode Screens
Figure 10-9	91	Boiler Model (Boiler Type) Decoding
Figure 10-10	92	Four Zone House (with Zone Control Connected)
Figure 10-11	92	Expected Heat Rate Adjustment (with Zone Control Connected)
Figure 10-12	104	Outdoor Reset Curve - Typical for Central Heat and Auxiliary Heat

Appendix B Figures *(continued)*

Figure Number	Page Number	Description
Section 11 - Service and Maintenance		
Figure 11-1	111	Igniter Electrode Gap
Figure 11-2	112	Condensate Overflow Switch Orientation
Figure 11-3	113	Control Compartment Access for Stacked Boiler Installations
Section 12 - Troubleshooting		
Figure 12-1	115	Help Menu
Section 13 - Service Parts		
N/A	Pages 121 through 133	
Appendix A		
A-1	134	
A-3	135	

Appendix C Tables

Table Number	Page Number	Description
Section 1 - Product Description, Specifications & Dimensional Data		
Table 1-4	7	Ratings
Table 1-5	7	Specifications
Table 1-6	7	Dimensions (see Figures 1-1 through 1-3)
Section 3 - Pre-Installation and Boiler Mounting		
Table 3-1	9	Corrosive Combustion air Contaminants and Sources
Table 3-2	10	Vent Pipe Clearances to Combustible Material
Table 3-4	11	Alpine Boiler Model Stacking Combinations
Section 4 - Venting		
Table 4-1	15	Vent/Combustion Air Intake System Options
Table 4-2	16	Vent and Combustion Air Pipe Sizes and Equivalent Lengths (Applies to All Listed Vent/Combustion Air System Options)
Table 4-3	16	Vent System and Combustion Air System Components Equivalent Length (Applies to All Listed Vent/Combustion Air System Options)
Table 4-4	16	Vent and Combustion Air Equivalent Length Calculation Work sheet
Table 4-11	22	CPVC/PVC Vent & Air Intake Components Included With Boiler
Table 4-12	22	CPVC/PVC Vent & Air Intake Components (Installer Provided) required for Optional Horizontal (Snorkel) Termination
Table 4-13	22	Components Required for Optional Ipex Profile Sidewall Termination
Table 4-14	22	CPVC/PVC Vent & Air Intake Components (Installer Provided) Required for Optional Vertical Roof Termination
Table 4-17	24	Expansion Loop Lengths
Table 4-21	27	Listed Polypropylene Vent System Manufacturers
Table 4-22	28	M&G DuraVent PolyPro Polypropylene Vent/Combustion Air System Components
Table 4-23	28	Listed Polypropylene Pipe, Fittings and Terminations - Centrotherm Eco
Table 4-24	29	Listed Polypropylene Pipe, Fittings and Terminations - Z-Flex Z-Dens
Table 4-30	32	Thermal Solutions (Heat Fab) Vent System Components (Stainless Steel, 4 in. only)
Table 4-31	32	M&G Dura FasNSeal Stainless Steel Vent Systems Components, Single Wall
Table 4-32	33	Z-Flex, Z-Vent (SVE Series III, Z-Vent III) Stainless Steel Vent System Components, Single Wall
Section 5 - Condensate Disposal		
Table 5-1	39	Maximum Condensate Flow
Section 6 - Water Piping and Trim		
Table 6-1	42	Flow Switch Paddle Application
Table 6-3	42	Flow Range Requirement Through Boiler
Table 6-4	43	Recommended Taco Circulators for 50 ft. Equivalent ft. Near Boiler Piping [Approximately 20 ft. Straight Pipe, (4) 90° Elbows, and (2) Full Port Ball Valves]
Table 6-5	43	Recommended Grundfos Circulators for 50 Equivalent ft. Near Boiler Piping [Approximately 20 ft. Straight Pipe, (4) 90° Elbows, and (2) Full Port Ball Valves]
Table 6-8	46	Fitting & Valve Equivalent Length
Table 6-11	49	Multiple Boiler Water Manifold Sizing

Appendix C Tables *(continued)*

Table Number	Page Number	Description
Section 7 - Gas Piping		
Table 7-1	53	Maximum Capacity of Schedule 40 Black Pipe in CFH* (Natural Gas) For Gas Pressures of 1/2 psi (3.4 kPa) or Less
Table 7-2	54	Maximum Capacity of Schedule 40 Black Pipe in CFH* (LP Gas) For Gas Pressures of 1/2 psig (3.4 kPa) or Less
Table 7-3	54	Equivalent Length of Standard Pipe Fittings & Valves (ft)
Table 7-4	54	Specific Gravity Correction Factors
Table 7-6	55	Min./Max. Inlet Gas Pressure Ratings
Section 8 - Electrical		
Table 8-1	58	Boiler Current Draw
Section 9 - System Start-Up		
Table 9-2	72	Natural Gas Typical Combustion Readings (Sea Level Only)
Table 9-3	72	LP Gas (Propane) Typical Combustion Readings (Sea Level Only)
Table 9-6	74	Approximate Clockwise Throttle Screw Turns for LP Gas (Propane) Conversion
Table 9-7	75	Approximate Counter-Clockwise Throttle Screw Turns from Fully Closed Position, Natural Gas
Table 9-8	75	Approximate Counter-Clockwise Throttle Screw Turns from Fully Closed Position, LP Gas (Propane)
Table 9-9	76	Field Wiring Checklist
Table 9-10	77	Control Parameter Checklist
Section 10 - Operation		
Table 10-1	79	Order of Priority
Table 10-2	81	Frost Protection
Table 10-3	83	Boiler Sequence of Operation
Section 13 - Service Parts		
N/A	Pages 123 through 134	
Appendix A - Instructions for High Altitude Installations Above 2,000 ft.		
Table A-2	135	Approximate Clockwise Throttle Screw Turns for LP Gas (Propane) Conversion
Table A-4	136	Alpine Altitude Adjustments

U.S. Boiler Company, LLC
P.O. Box 3020
Lancaster, PA 17604
1-888-432-8887
www.usboiler.net