



MAH-125

MAC-150

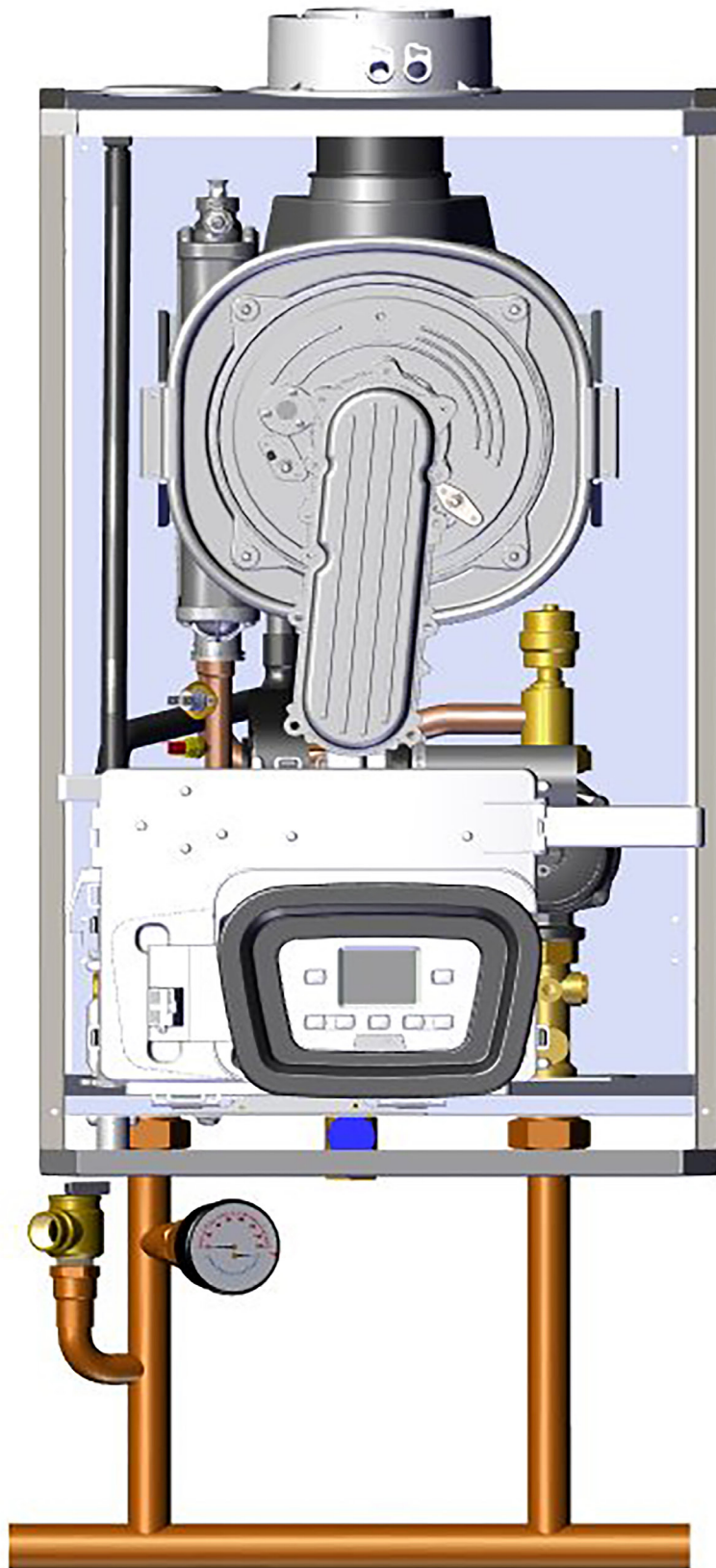
MAH-165

MAC-205

**CONDENSING
WALL MOUNTED
GAS FIRED BOILER**



MAC-205



CONTENTS :

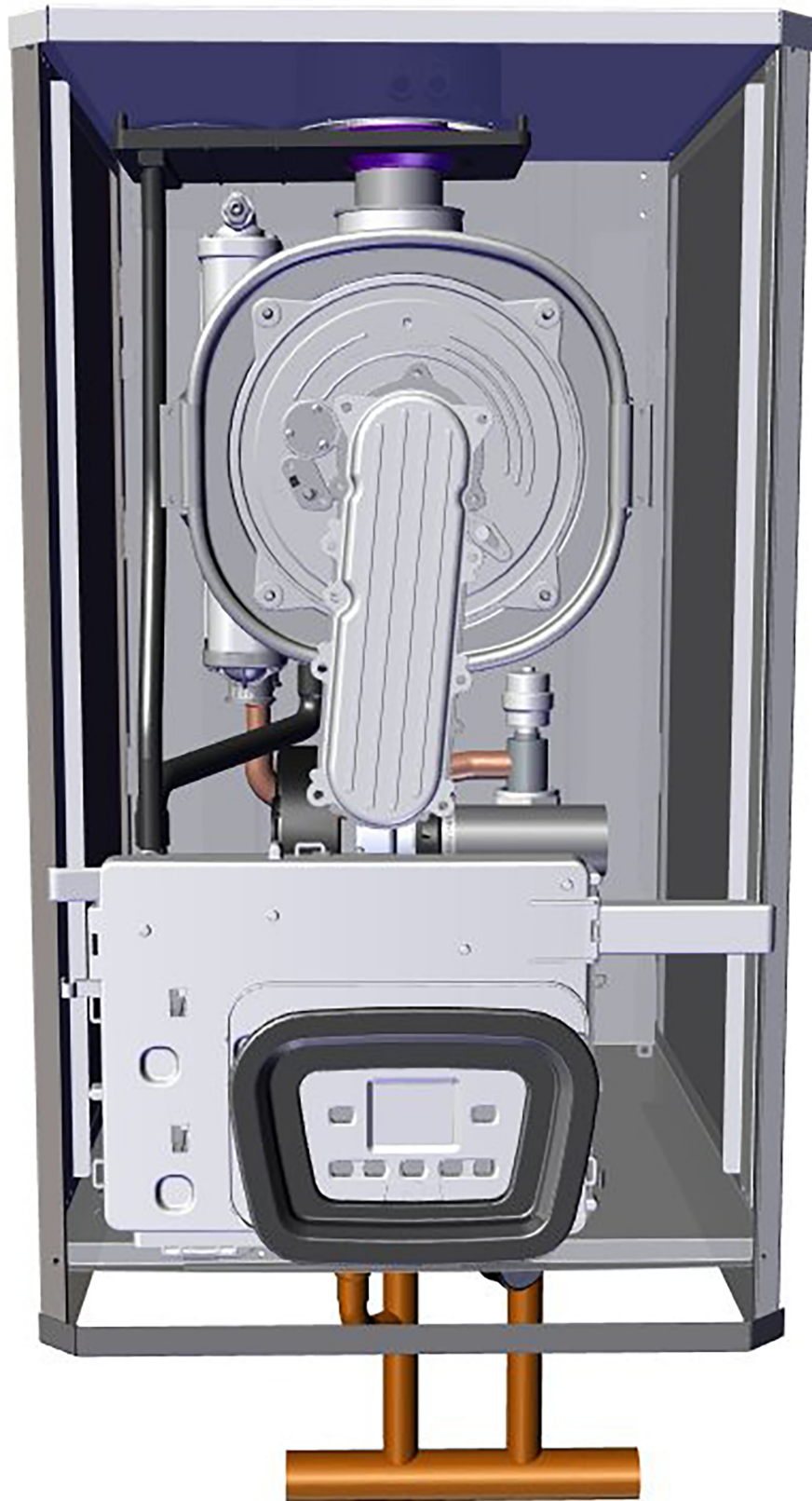
*INSTALLATION, OPERATION,
AND MAINTENANCE MANUAL*
(240011941)

APPLICATION GUIDE
(240011430)

COMMISSIONING
GUIDE
(240011376)

REQUIRED
INSPECTION SPECIAL
(240011561)
BACK COVER

MAH-165





CONDENSING WALL MOUNTED
GAS FIRED

**INSTALLATION, OPERATION &
MAINTENANCE MANUAL**



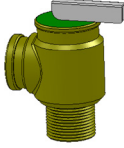



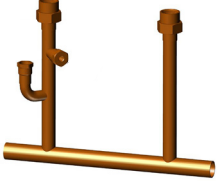
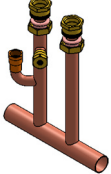
Models

MAH-125, MAC-150
MAH-165, MAC-205



Manufactured by:
ECR International Inc.
2201 Dwyer Avenue, Utica, NY 13501
Tel. 800 253 7900
www.ecrinternational.com
PN 240011941 REV C, [07/31/2018]

VERIFY CONTENTS RECEIVED

			
<p align="center">Fully Assembled Boiler</p>	<p align="center">Metal Wall Bracket w/ 4 ea Wall Screws and Plugs</p>	<p align="center">30 PSI Safety Relief Valve</p>	<p align="center">Temperature Pressure Gauge</p>
		<p align="center">4 ea - 17x24x2 Gaskets</p>	<p align="center">Includes Essential Documents and Warranty 11x17 Wire Diagrams</p>
<p align="center">Drain Valve</p>	<p align="center">*5 GPM Flow Restrictor 205 Combi Only</p>	<p align="center">Used for Valve Connections</p>	<p align="center">Document Package</p>
		<p align="center">Wall Mount Template</p>	
<p align="center">*Manifold</p>	<p align="center">*Manifold 165 Heat-Only</p>	<p align="center">Template</p>	

* Verify proper unit size before use.

TABLE OF CONTENTS

1 - Important Information.....	6
2 - Introduction.....	7
3 - Component Listing	8
4 - Locating Boiler	12
5 - Hydronic Piping.....	15
5.1 General	15
5.2 Special Conditions.....	16
5.3 Safety Relief Valve and Air Vent	16
5.4 Trim Piping.....	17
5.5 System Piping	17
5.6 Low Water Cut Off.....	19
5.7 Recommendation - Use of Strainer	20
5.8 Central Heating System	21
5.9 Domestic Hot Water Mode	21
5.10 Frost Protection Mode	21
5.11 Pump Protection	21
6 - Combustion Air And Vent Piping.....	22
6.1 General	22
6.2 Removal of Existing Boiler.....	22
6.3 Definitions	23
6.4 Securing Twin Pipe Polypropylene Venting	23
6.5 Approved Venting Materials	24
6.6 Vent Termination	24
6.7 Coaxial Venting Instructions	25
6.8 Coaxial Screw Placement	25
6.9 Twin Pipe Systems	27
6.10 Flexible Vent System.....	30
6.11 Condensate Piping.....	32
7 - Gas Supply Piping	33
7.1 General	33
7.2 Leak Check Gas Piping.....	33
8 - Electrical Connections	34
8.1 General	34
8.2 Install Room Thermostat.....	34
8.3 Electrical Connections.....	34
8.4 Access To Connection Block	35
8.5 Main Supply Connection.....	35
8.6 Install Room Thermostat.....	36
8.7 Optional Electrical Connections	37
8.8 Indirect Storage Tank	38
9 - Start Up Procedure.....	39
9.1 Central Heating System Heat Only	39
9.2 Central Heating System Combi	40
9.3 System Start Up	41
9.4 Fill Condensate Trap with Water	41
9.5 Control Panel.....	42
9.6 Commissioning	43
9.7 Calibration Function.....	43
9.8 De-Aeration Function.....	44
9.9 Commission Set Up (Gas)	44
9.10 Chimney Sweep Function (CO2 Adjust)	45
9.11 Combustion Adjustment Function	45
9.12 Check Firing Rate.....	45
9.13 Parameter Settings.....	46
9.14 Description Of Parameters: Factory Settings.....	46
9.15 Adjusting Maximum Heating Power.....	48
10 - Operating instructions	49
10.1 Boiler Sequence Of Operation	49
10.2 Testing For Gas Leaks And Purging	49
10.3 Boiler Controls	50
10.4 Boiler Operation.....	51
10.5 Central Heating Mode	51
10.6 Domestic Hot Water Mode	51
10.7 Frost Protection	51
10.8 Pump	51
10.9 Low Water Pressure Sensor	51
11 - General Maintenance and Cleaning.....	52
11.1 Beginning of Each Heating Season.....	52
11.2 Maintenance And Routine Servicing	53
11.3 Component Replacement And Cleaning.....	53
11.4 Draining the Boiler	54
11.5 Draining the Heating Circuit.....	54
11.6 Hydraulic Unit (DHW)	55
11.7 Cleaning The Cold Water Filter	55
11.8 Final Commissioning.....	55
11.9 Final Assembly.....	55
11.10 User Information.....	56
11.11 Safety Flue Thermostat.....	56
11.12 Flue Pressure Switch	56
11.13 Replacement Parts.....	56
11.14 Automatic Calibration Function	56
12 - Ratings And Capacities.....	57
12.1 Ratings and Capacity	57
12.2 Domestic Hot Water Specifications.....	57
12.3 High Altitude Parameter	58
13 - Trouble Shooting.....	59
13.1 Error Messages And Resetting The Boiler...	59
14 - Glossary	60
Appendix A - Wiring Diagrams.....	62

PHYSICAL DATA

Dimensions

DIMENSIONS		125 & 150	205 & 165
A	Height	30" [763 mm]	30" [763 mm]
B	Width	17 ¾" [450 mm]	17 ¾" [450 mm]
C	Depth	13 ⅞" [345 mm]	21 ½" [571 mm]
D	Condensate Trap Connection	13/16" [21mm] ID Hose	3/4" [19.1 mm] NPT
E	System Supply	3/4" [19.1 mm]	1" [25.4mm]
F	DHW Outlet (125 Optional)	1/2" [15.9 mm]	3/4" [19.1 mm]
G	Gas Connection	3/4" [19.1 mm]	3/4" [19.1 mm]
H	DHW (Cold Water) Inlet	1/2" [15.9 mm]	3/4" [19.1 mm]
I	System Return	3/4" [19.1 mm]	1" [25.4mm]
J	Boiler Filling Connection	1/2" [15.9mm]	External to Boiler
Primary Water Content		1 gal [3.60 L]	1½ gal [4.73 L]

SYSTEM

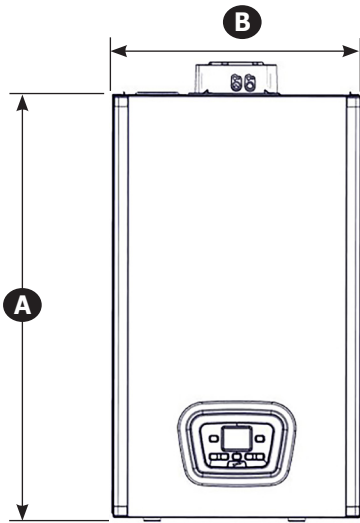
Central Heating (Sealed System)	125 / 150	165/ 205
Heat Exchanger Max Allowable Working Pressure	50 psi [3.45 bar]	50 psi [3.45 bar]
Max System Pressure	43.00 psi [2.96 bar]	43.00 psi [2.96 bar]
Min System Pressure	7.25 psi [0.50 bar]	7.25 psi [0.50 bar]
Max System temperature	176°F [80°C]	176°F [80°C]
Pressure Relief Valve Setting	30.00 psi [2.11 bar]	30.00 psi [2.11 bar]
Expansion Tank Minimum Size (pre-charge press.)	2.2 gal at 11.6 psi [10.0 L at 0.8 bar]	2.2 gal at 11.6 psi [10.0 L at 0.8 bar]
Recommended System Pressure (cold)	21.7 psi [1.5 bar]	21.7 psi [1.5 bar]

Domestic Hot Water (Sealed System)	150	205
Max Inlet Water Pressure	116 psi [8 bar]	116 psi [8 bar]
Min Inlet Water Pressure	2.9 psi [0.2 bar]	2.9 psi [0.2 bar]
Min DHW Flow Rate	0.55 gpm [2.50 L/min]	0.55 gpm [2.50 L/min]
Max DHW Temperature	140°F [60°C]	140°F [60° C]
DHW Water Content	0.05 gal [0.23 L]	0.10 gal [0.37 L]

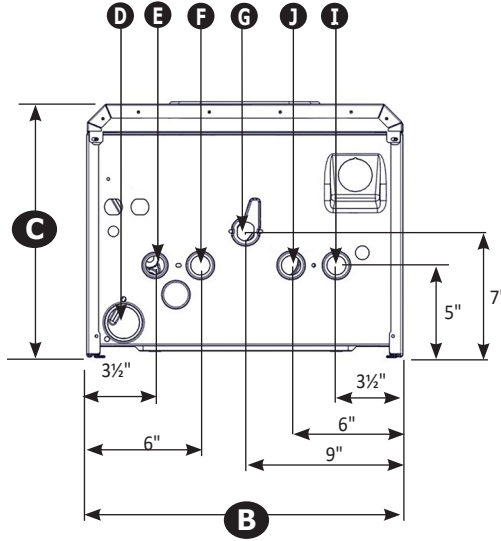
When boiler is operating at maximum operating temperature, providing heating with all heat emitters operating, pressure gauge should not indicate more than 26.11 psi / 1.80 bar. If reading exceeds this figure larger expansion tank is required.

PHYSICAL DATA

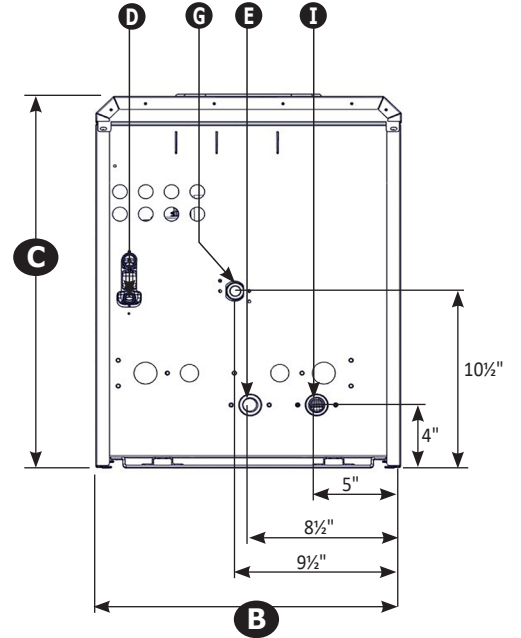
**Front View
All Models**



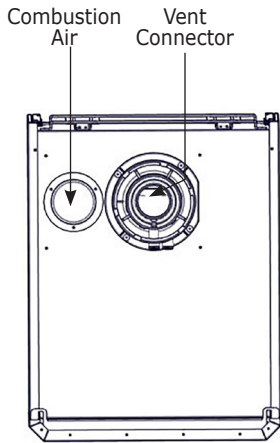
**125 HEAT ONLY
Bottom View
Dimensions**



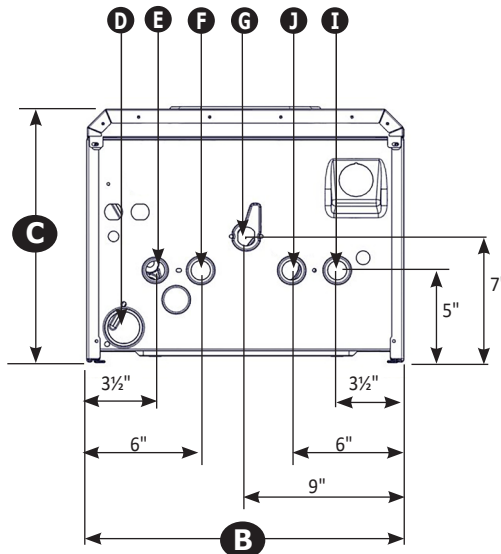
**165 HEAT ONLY
Bottom View
Dimensions**



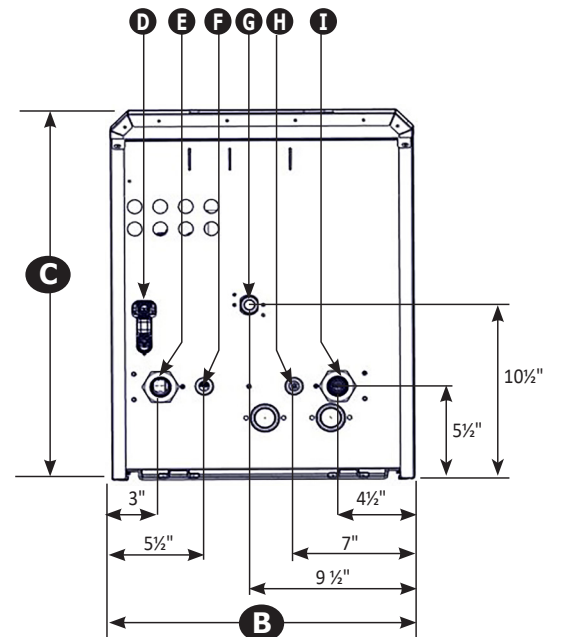
**Top View
All Models**



**150 COMBI
Bottom View
Dimensions**



**205 COMBI
Bottom View
Dimensions**



1 - IMPORTANT INFORMATION

1. Safety Information

Boiler installation shall be completed by qualified agency. See glossary for additional information.

WARNING

Fire, explosion, asphyxiation and electrical shock hazard. Improper installation could result in death or serious injury. Read this manual and understand all requirements before beginning installation.

WARNING

Do not tamper with or use this boiler for any purpose other than its intended use. Failure to follow these instructions could result in death or serious injury. Use only manufacturer recommended parts and accessories.

CAUTION

Laceration, burn hazard. Metal edges and parts may have sharp edges and/or may be hot. Use appropriate personal protection equipment to include safety glasses and gloves when installing or servicing this boiler. Failure to follow these instructions could result in minor or moderate injury.

Become familiar with symbols identifying potential hazards.



This is the safety alert symbol. Symbol alerts you to potential personal injury hazards. Obey all safety messages following this symbol to avoid possible injury or death.

DANGER

Indicates a hazardous situation which, if not avoided, WILL result in death or serious injury.

WARNING

Indicates a hazardous situation which, if not avoided, could result in death or serious injury.

CAUTION

Indicates a hazardous situation which, if not avoided, could result in minor or moderate injury.

NOTICE

Used to address practices not related to personal injury.

FOR YOUR SAFETY READ BEFORE OPERATING



DANGER



Hot Water Can Scald!

Water heated to temperature for clothes washing, dish washing and other sanitizing needs can scald and cause permanent injury.

Children, elderly, and infirm or physically handicapped persons are more likely to be permanently injured by hot water. Never leave them unattended in bathtub or shower. Never allow small children to use a hot water tap or draw their own bath.

If anyone using hot water in the building fits the above description, or if state laws or local codes require certain water temperatures at hot water taps, you must take special precautions:

- Use lowest possible temperature setting.
- Install some type of tempering device, such as an automatic mixing valve, at hot water tap or water heater. Automatic mixing valve must be selected and installed according to manufacturer's recommendations and instructions.
- Water passing out of drain valves may be extremely hot. To avoid injury:
 - Make sure all connections are tight.
 - Direct water flow away from any person.

Water Temperature Setting	1st Degree Burn Exposure Time For An Adult	2nd and 3rd Degree Burn Exposure Time For An Adult
120° F	1 minute	5 minutes
130° F	5 seconds	30 seconds
140° F	2 seconds	5 seconds
150° F	1 second	1.5 seconds
160° F	Instantaneous	0.5 seconds

Note: Warning for Infants, Children, and Elderly: Great care must be taken when exposing the aforementioned groups to warm or hot water as they can be badly burned in exposure times less than half of the time for an adult.

2 - INTRODUCTION

2 - Introduction

2.1 Installation shall conform to requirements of authority having jurisdiction or in absence of such requirements:

UNITED STATES

- National Fuel Gas Code, ANSI Z223.1/NFPA 54.
- National Electrical Code, NFPA 70.

CANADA

- Natural Gas and Propane Installation Code, CAN/CSA B149.1.
- Canadian Electrical Code, Part I, Safety Standard for Electrical Installations, CSA C22.1

2.2 Where required by authority having jurisdiction, installation shall conform to Standard for Controls and Safety Devices for Automatically Fired Boilers, ANSI/ASME CSD-1. Additional manual reset low water cutoff may be required.

2.3 Requirements for Commonwealth of Massachusetts:

Boiler installation must conform to Commonwealth of Massachusetts code 248 CMR which includes but is not limited to:

Installation by licensed plumber or gas fitter.

2.4 Manufacturer recommends use of Carbon Monoxide monitor may be requirement of local jurisdiction.

2.5 Designated Use

- MAC-150 and MAC -205 provide both central heating and domestic hot water.
- MAH-125 and MAH-165 central heating only.
- Indoor installation.
- Closet or alcove installation. Direct Vent Boiler does not require air vents when installed in closet or room.
- Direct vent boiler.
- For use with natural gas or liquefied petroleum gases (LP/propane).

2.6 The unit MUST NOT:

- Directly heat potable water. Indirect heating is acceptable.
- Heat water with non-hydronic heating system chemicals present (example, swimming pool water).
- Toxic chemicals, such as those used for boiler treatment, shall not be introduced into potable water used for space heating.
- Exceed 43 psig (2.96bar) maximum allowable working pressure, or drop below minimum system pressure 7.25 psig (.50 bar)
- Exceed 176°F (80°C) system design temperature.

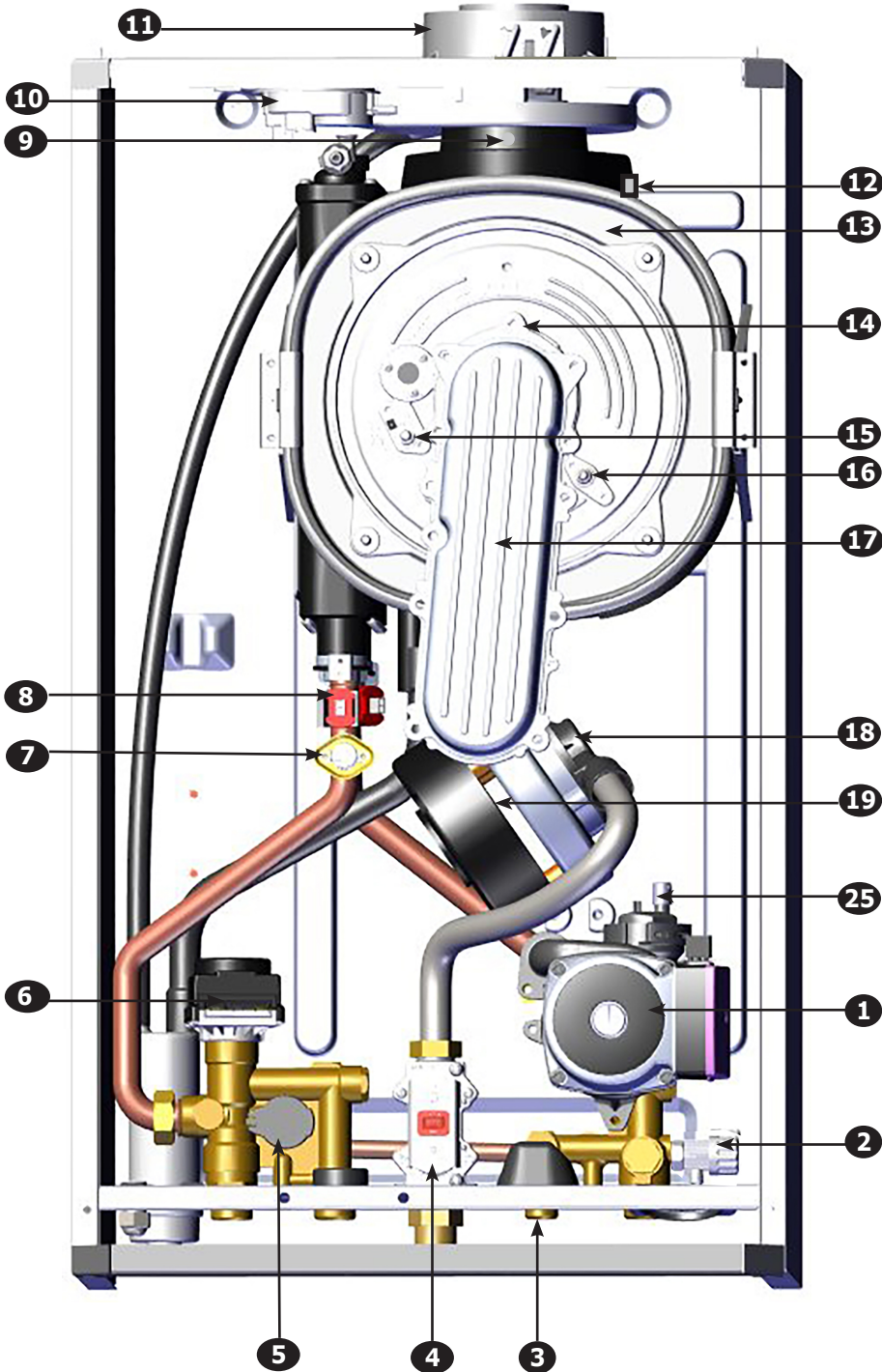
2.7 Operational Features

- Modulates to provide CH Turndown 5.5:1, DHW Turndown 7:1.
- Maximum output available for domestic hot water:
MAC-150 - 136,000 btu/h (40 kW), capable of providing 3.5 (U.S.) gpm (13.2 liters/min) with a temperature rise of 70°F/39°C.
MAC-205 - 180,000 btu/h (53 kW), capable of providing 5.0 (U.S.) gpm (18.9 litres/min) with temperature rise of 70°F/39°C.
- Integral Low Water Pressure Cutoff.
- Optional Outdoor Temperature Reset.
- Heat exchanger over heat protection.
- Boiler operating at maximum operating temperature, providing heat, pressure gauge should not indicate more than 26.11 psi / 1.80 bar. If reading exceeds this figure larger expansion tank is required.

Check our website frequently for updates: www.ecrinternational.com

Information and specifications outlined in this manual in effect at the time of printing of this manual. ECR International reserves the right to discontinue, change specifications or system design at any time without notice and without incurring any obligation, whatsoever.

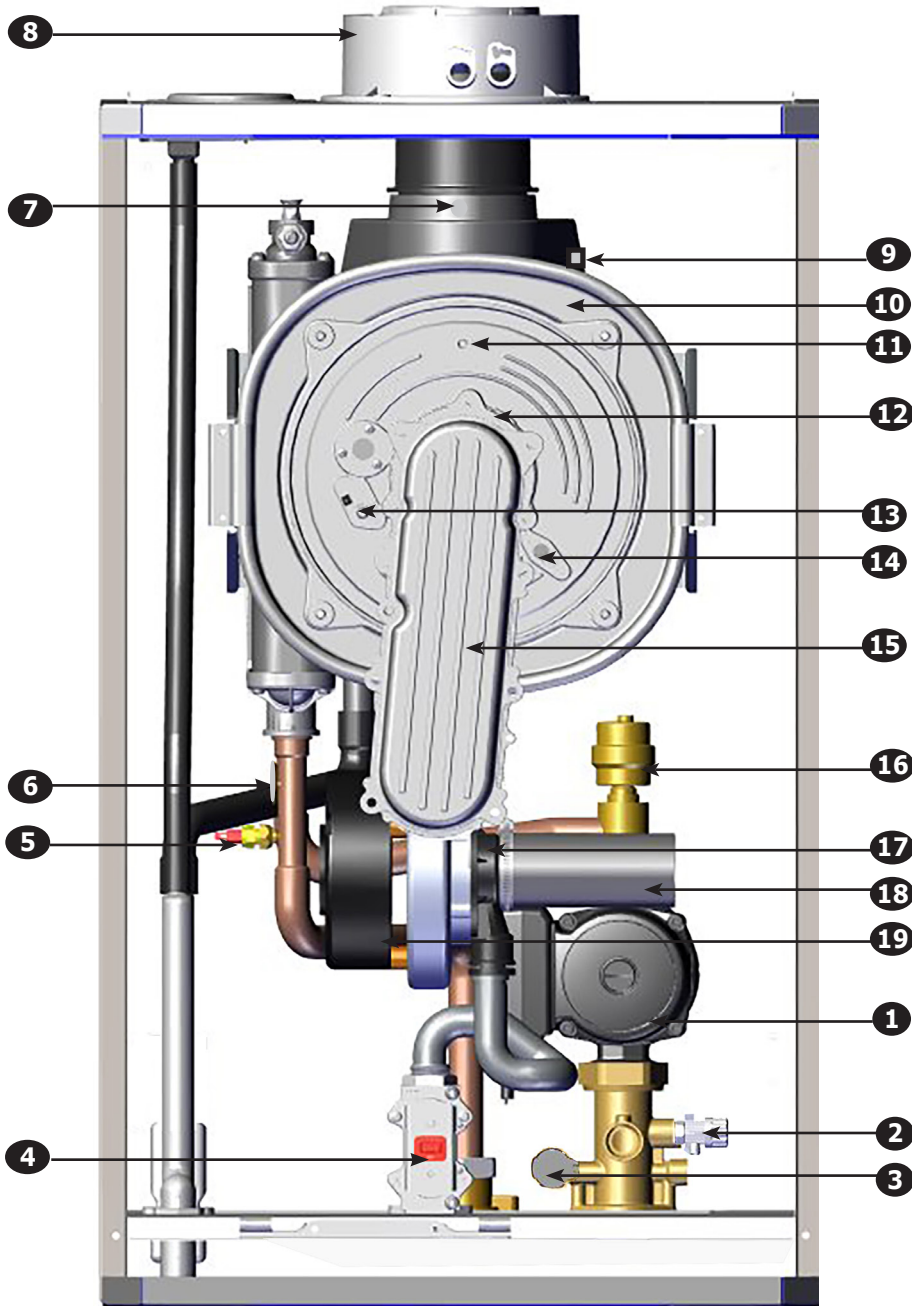
UTICA BOILER MAH-125



ITEM NO.	Utica Boiler MAH-125
1	Pump with Air Separator
2	Boiler Drain Tap
3	Boiler Filling Tap
4	Gas Valve
5	Low Water Pressure Cutoff
6	3-Way Valve with Motor
7	Water Safety Thermostat
8	NTC Heating sensor (Flow/Return) QTY 2, (1 Shown for clarity)
9	Flue Sensor
10	Pressure Switch
11	Coaxial Flue Connector
12	Heat Exchanger Temperature Sensor
13	Heat Exchanger
14	Burner (not shown)
15	Ignition electrode
16	Flame Detection Electrode
17	Air/Gas Manifold
18	Venturi
19	Fan

Illustrations are a depiction of the boiler for general location of parts and may vary depending on model.

UTICA BOILER MAH-165

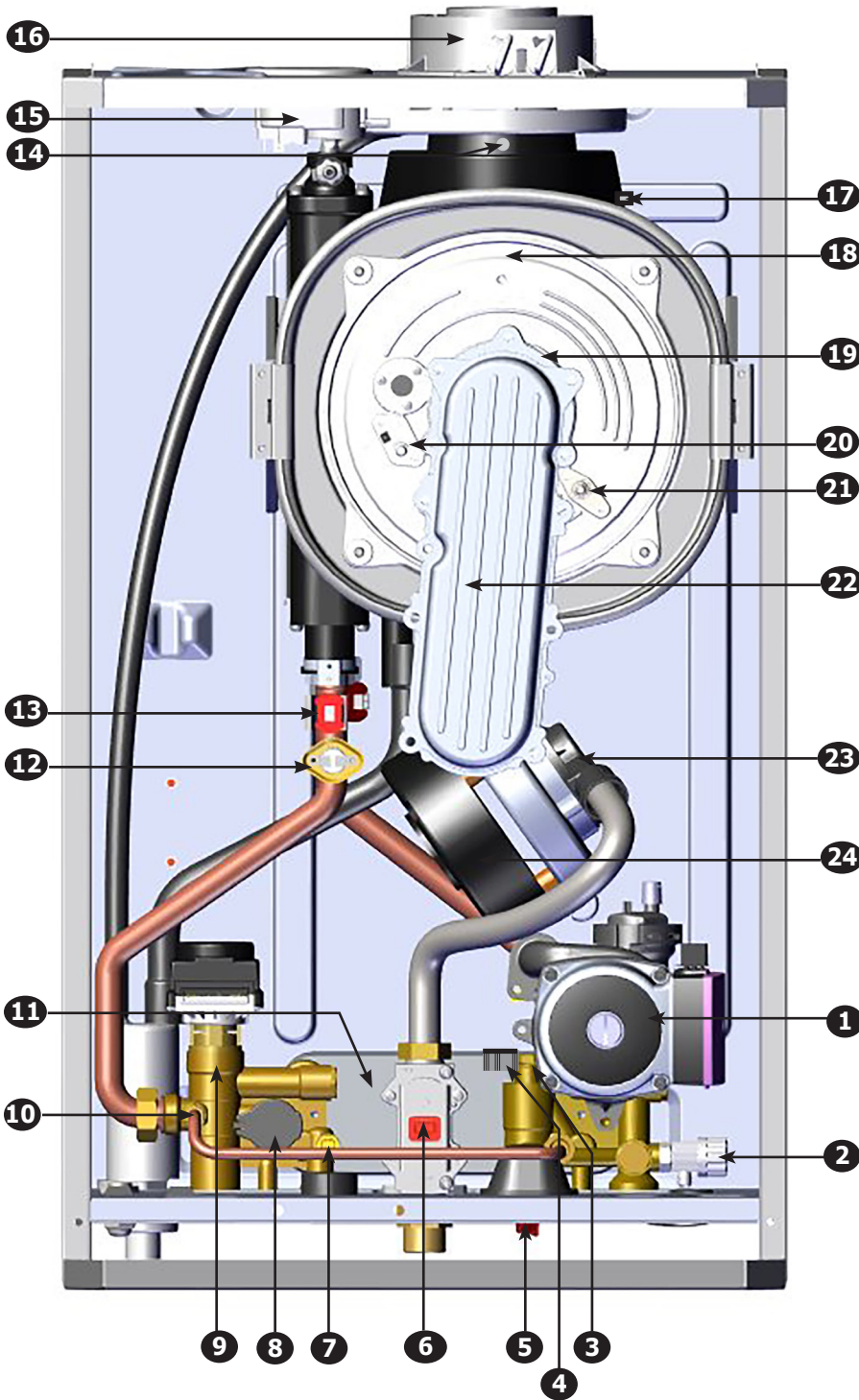


ITEM NO.	Utica Boiler MAH-165
1	Pump
2	Boiler Drain Tap
3	Low Water Pressure Cutoff
4	Gas Valve
5	NTC Heating sensor (Flow/Return) QTY 2, (1 Shown for clarity)
6	Water Safety Thermostat
7	Flue Sensor
8	Coaxial Connector
9	Heat Exchanger Temperature Sensor
10	Heat Exchanger
11	Burner Door Temperature Sensor
12	Burner (not shown)
13	Ignition Electrode
14	Flame Detection Electrode
15	Air/Gas Blend Manifold
16	Air Purge
17	Venturi
18	Silencer
19	Fan

Illustrations are a depiction of the boiler for general location of parts and may vary depending on model.

3 - COMPONENT LISTING

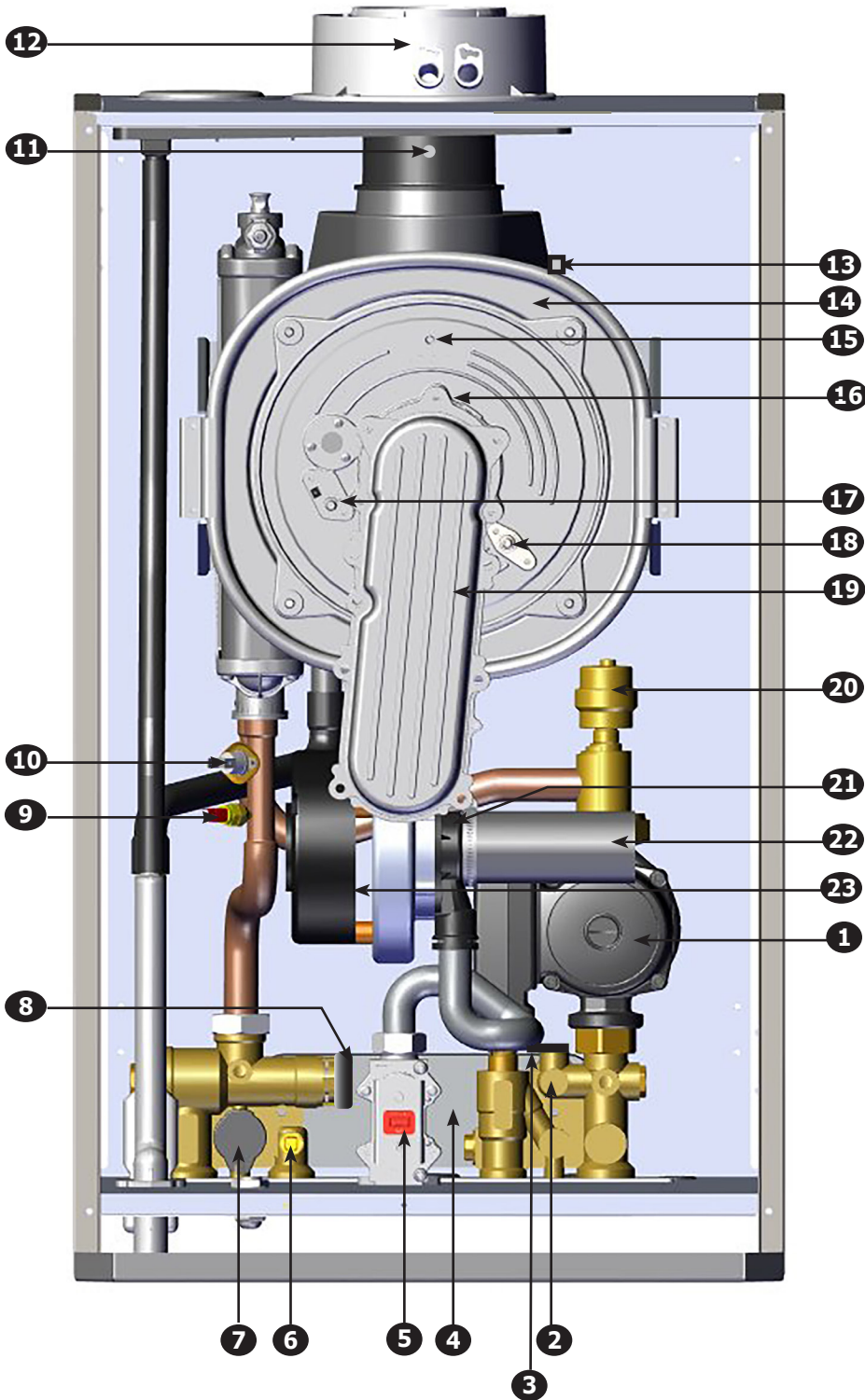
UTICA BOILER MAC-150



ITEM NO.	Utica Boiler MAC- 150
1	Pump with Air Separator
2	Boiler Drain Tap
3	Flow Sensor with Water Filter and Flow Restrictor
4	DHW Priority Sensor
5	Boiler Filling Tap
6	Gas Valve
7	NTC DHW Sensor
8	Low Water Pressure Cutoff
9	3-Way Valve with Motor
10	Check Valve
11	DHW Heat Exchanger
12	Water Safety Thermostat
13	NTC Heating sensor (Flow/Return) QTY 2, (1 Shown for clarity)
14	Flue Sensor
15	Pressure Switch
16	Coaxial Connector
17	Heat Exchanger Temperature Sensor
18	Heat Exchanger
19	Burner (not shown)
20	Ignition Electrode
21	Flame Detection Electrode
22	Air/Gas Blend Manifold
23	Venturi
24	Fan

Illustrations are a depiction of the boiler for general location of parts and may vary depending on model.

UTICA BOILER MAC-205



ITEM NO.	Utica Boiler MAC-205
1	Pump
2	Flow Sensor
3	DHW Priority Sensor
4	DHW Heat Exchanger
5	Gas Valve
6	NTC DHW Sensor
7	Low Water Pressure Cutoff
8	3-Way Valve with Motor
9	NTC Heating sensor (Flow/Return) QTY 2, (1 Shown for clarity)
10	Water Safety Thermostat
11	Flue Sensor
12	Coaxial Connector
13	Heat Exchanger Temperature Sensor
14	Heat Exchanger
15	Burner Door Temperature Sensor
16	Burner (not shown)
17	Ignition Electrode
18	Flame Detection Electrode
19	Air/Gas Manifold
20	Air Purge
21	Venturi
22	Silencer
23	Fan

Illustrations are a depiction of the boiler for general location of parts and may vary depending on model.

4 - LOCATING BOILER

WARNING

Fire Hazard! Do not install on carpeting. Failure to follow these instructions could result in death or serious injury.

4.1 Boiler Location Considerations

- Ambient room temperature always above 32°F (0°C) to prevent freezing of liquid condensate.
- Approved for installation in closets or alcove provided it is correctly designed for that purpose and minimum clearances are met.
- Protect gas ignition system components from water (dripping, spraying, rain, etc.) during operation and service (circulator replacement, condensate trap, control replacement, etc.).
- Access to outdoors to meet minimum and maximum pipe lengths for combustion air and vent piping. See section 6.
- Disposal of condensate. See section 6.
- Drainage of water (or water - antifreeze solution) during boiler service or from safety relief valve discharge. See section 5.
- Access to system water piping, gas supply, and electrical service. See sections 5, 7 and 8.
- Clearances to combustible materials and service clearances. See Table 1 and Figures pg. 13.
- Boiler shall be installed on flat vertical wall which is capable of supporting the weight of the boiler.
- Room-sealed boiler installed in a room containing bath or shower shall be installed so person using bath or shower cannot touch any electrical switch or boiler control utilizing line voltage electricity.
- Multiple Boilers can be wall mounted, placed side by side, or back to back.
- Observe service clearances in all installations.
- For Direct Vent installations, air vents are not required in room boiler is installed in, or when installed in closet or compartment.

TABLE 1: BOILER CLEARANCES

Dimension	Combustible Materials ⁽¹⁾	Manufacturer Recommended for Service ⁽¹⁾⁽²⁾
Top	0" (0 cm)	8-5/8" (220 mm)
Left Side	1-3/4" (45 mm)	1-3/4" (45 mm)
Right Side	1-3/4" (45 mm)	1-3/4" (45 mm)
Front	0" (0 mm)	17-3/4"(450mm)
Back	0" (0 mm)	0" (0 mm)
Bottom	0" (0 mm)	*9-13/16" (250 mm)
Combustion Air/ Vent piping	0" (0 mm)	6" (160 mm)

⁽¹⁾ Required distances measured from boiler jacket.

⁽²⁾ Service, proper operation clearance recommendation.

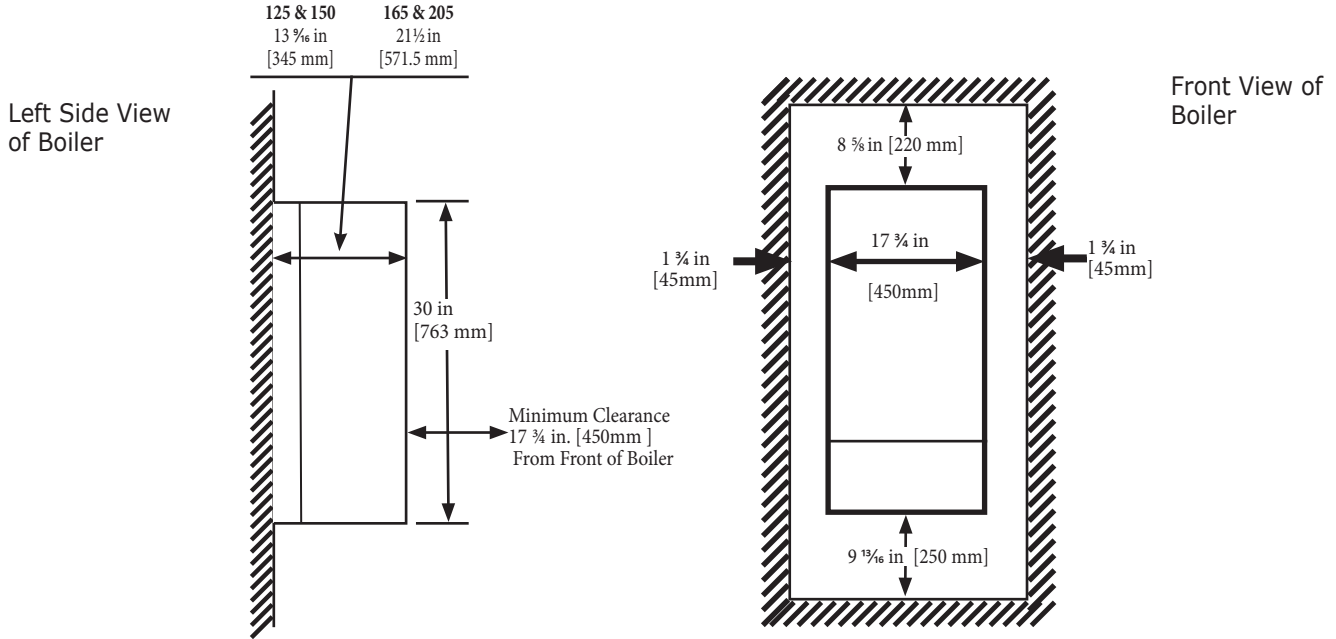
* Allowance for piping at the bottom of boiler not included.

NOTE: Greater clearances for access should supersede fire protection clearances.

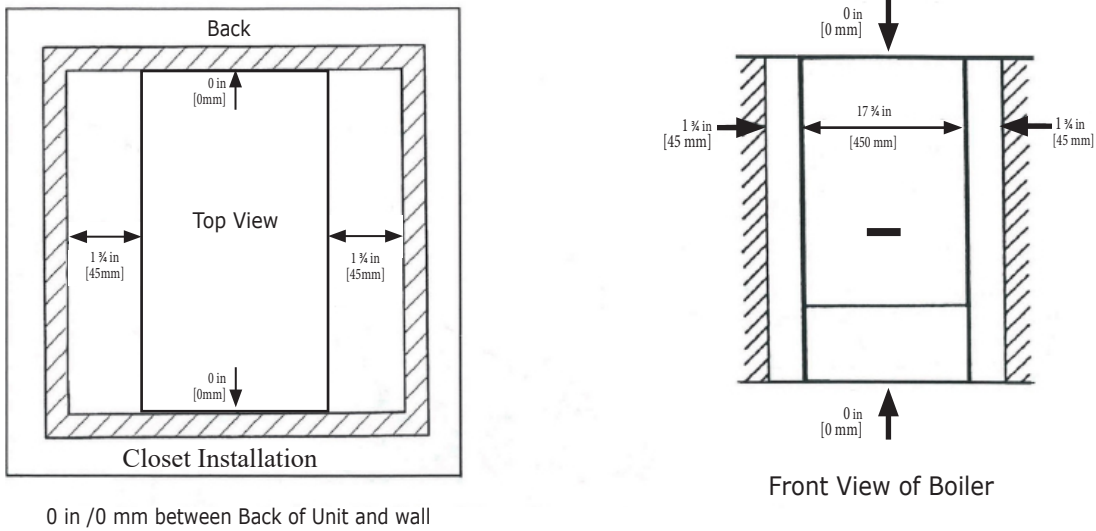
4 - LOCATING BOILER

4.2 Clearances

Service Clearances



Combustible Clearances



4 - LOCATING BOILER

CAUTION

Boiler weight exceeds 140 pounds (63.5 kg). Do not lift boiler onto wall without assistance.

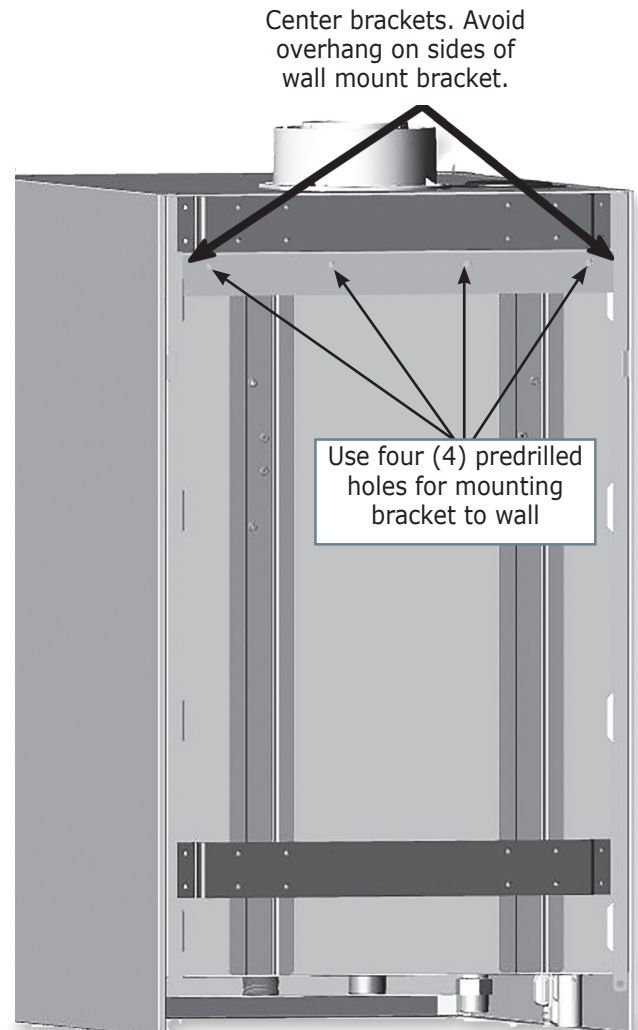
Note Lift boiler using chassis. Do not use front jacket, vent piping, water or gas fittings to lift boiler as it may cause damage to the boiler.

Note Use two (2) wrenches when tightening and fitting to pipe boiler's threaded fittings. Boiler's internal piping can be damaged if subjected to excessive torque.

4.2 Wall Mounting

1. Decide position of boiler on the wall allowing for all required clearances and flue terminal position.
2. Tape template to the wall. Ensure template is level and upright. Mark position of holes for boiler mounting bracket and plumbing connections.
3. Rear exit flue - mark position of hole for flue.
4. Side exit flue - mark horizontal center line of flue across the wall to side wall, then along side wall (ensure lines are parallel and sloped properly towards the boiler, refer to section 6. This will give position of center of hole for flue.
5. Cut hole in wall for coaxial flue. See sizing below:
 - 125 & 150 - 4 $\frac{3}{8}$ " [110 mm] diameter
 - 165 & 205 - 5 $\frac{5}{16}$ " [135 mm] diameter
6. Pre-pipe supply and return water connections with factory fittings before wall mounting.
7. Mount boiler on wall using wall mounting bracket included with unit.
8. Adjust the position of the boiler verify it is level.

FIGURE 4-2 Wall Mount Bracket (Included)



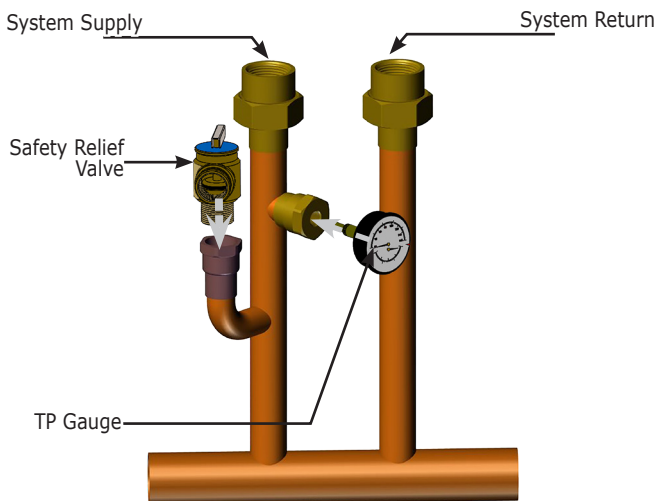
5 - HYDRONIC PIPING

Note Boiler rated at 50 psig (345 kPa) maximum allowable working pressure. Boiler provided with 30 psig (206 kPa) safety relief valve.

Note When installing safety relief valve it must be installed in a vertical position with spindle at top.

Note System pressure above 43 psi [2.96 bar] **WILL** result in boiler shutting down.

FIGURE 5-1 Safety Relief Valve



WARNING

- Poison hazard. Ethylene glycol is toxic. Do not use ethylene glycol.
- Never use automotive or standard glycol antifreeze, even ethylene glycol made for hydronic systems.
- Ethylene glycol can attack gaskets and seals used in hydronic systems.
- Do not use petroleum based cleaning or sealing compounds boiler system.
- Do not fill boiler or boiler system with softened water.
- Use only inhibited propylene glycol solutions certified by fluid manufacturer as acceptable for use with closed water heating system.
- Thoroughly clean and flush any system that used glycol before installing new Boiler.
- Provide user with Material Safety Data Sheet (MSDS) on fluid used.

WARNING

Boiler and its individual shutoff valve shall be disconnected from gas supply piping system during any pressure testing of that system at test pressures in excess of 1/2 psi (3.40 kPa - 34.47 mbar). Boiler shall be isolated from the gas supply piping system by closing its individual manual shutoff valve during any pressure testing of gas supply piping system at test pressures equal to or less than 1/2 psi (3.5 kPa). Install boiler so that gas ignition system components are protected from water (dripping, spraying, rain, etc.) during appliance operation and service (circulator replacement, condensate trap, control replacement, etc.).

5.1 General

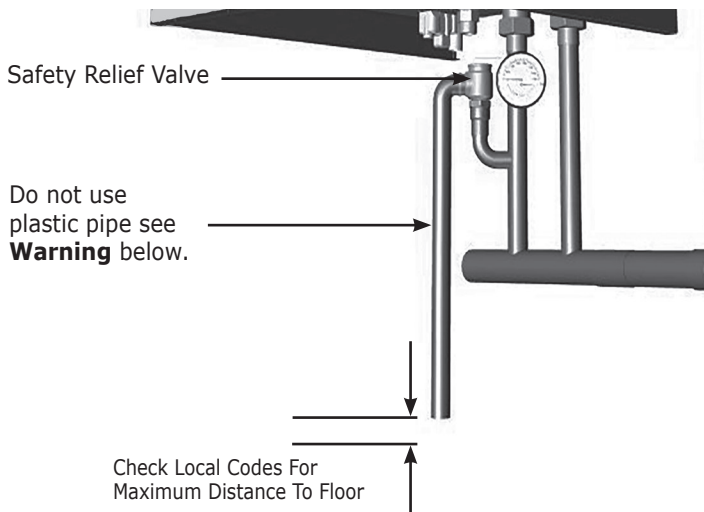
- Primary/Secondary piping required.
- Install piping in accordance with authority having jurisdiction.
- Support system piping and safety relief valve discharge piping. Boiler's internal piping and wall mount bracket can be damaged if subjected to excessive weight.

NOTICE

The intended use of the internal heat exchanger pump is a boiler loop. Do not use as a primary system pump.

- Size central heating pump (and domestic hot water pump, if used) for system requirements only. Internal heat exchanger pump compensates for pressure drop through boiler internal piping and heat exchanger.
- Thoroughly clean and flush system before connecting to boiler.
- If oil is present in system water, use approved detergent to wash system.
- It is necessary to semi-annually check the water quality of central heating systems.
- Manufacturer recommends installation of magnetic dirt separator in the hydronic system where there are cast iron or steel components, or where the previous boiler was a cast iron heat exchanger. The abrasive, extremely fine sediment is difficult to remove and can deposit onto heat exchange surfaces and accumulate in pump cavities causing reduced efficiency and premature wear.
- Flush system to remove any solid objects such as metal chips, fibers, or Teflon tape, etc.
- Flush system until water runs clean and piping is free of sediment.
- Use purge valve to flush zoned systems, each zone separately. If purge valves and isolation valves are not installed, install them to properly clean the system.
- When purging installations that include standing iron radiators and systems with manual vents at high points, start with nearest manual air vent. Open the vent until water flows out, then close vent. Repeat this procedure, working toward furthest air vent.
- Install a basket strainer if large amounts of sediment is present. Keep basket clear of sediment build up.
- Manufacturer recommends a water treatment product be used for sediment removal.
- Ensure piping in the heating system has an oxygen barrier.

FIGURE 5-2 Safety Relief Valve Discharge Piping



⚠ **WARNING**

Burn and scald hazard. Safety relief valve could discharge steam or hot water during operation. Use pipe suitable for temperatures of 375°F (191°C) or greater. DO NOT use plastic pipe.

5.2 Special Conditions

▶ **Note**

Do not expose boiler and condensate piping to freezing temperatures.

- System piping exposed to freezing conditions: Use inhibited propylene glycol solutions certified by fluid manufacturer for use with closed water heating system. Do not use automotive or ethylene glycol.
- Boiler installed above radiation level (or as required by authority having jurisdiction). Integral low water pressure switch is provided in boiler.
- Boiler used in connection with refrigeration system. Install piping in parallel with boiler, with appropriate valves to prevent chilled medium from entering boiler.
- System piping connected to heating coils located in air handling unit exposed to refrigerated air circulation. Install flow control valves or other automatic means to prevent gravity circulation of boiler water during cooling cycle.

⚠ **WARNING**

Burn and scald hazard. Safety relief valve could discharge steam or hot water during operation. Install discharge piping per these instructions.

5.3 Safety Relief Valve and Air Vent

- Install safety relief valve using pipe fitting provided with boiler. See Figure 5-2.
- Install safety relief valve with spindle in vertical position.
- Do not install shutoff valve between boiler and safety relief valve.
- Install discharge piping from safety relief valve. Do not use plastic pipe.
- Use ¾" or larger pipe.
- Use pipe suitable for temperatures of 375°F (191°C) or greater. Do not use plastic pipe on safety relief valve.
- Individual boiler discharge piping shall be independent of other discharge piping.
- Size and arrange discharge piping to avoid reducing safety relief valve relieving capacity below minimum relief valve capacity stated on rating plate.
- Run pipe as short and straight as possible to location protecting user from scalding and properly drain piping.
- Install union, if used, close to safety relief valve outlet.
- Install elbow(s), if used, close to safety relief valve outlet and downstream of union (if used).
- Terminate pipe with plain end (not threaded).

5.4 Trim Piping

- Temperature - Pressure Gauge. Install temperature pressure gauge using piping provided with boiler. See Figure 5-1.
- Some boiler models may have integral drain valve located inside jacket directly underneath pump. Install provided external drain valve as required.

5.5 System Piping

- Ensure caps are removed from boiler water connections.
- See Figure 5-9 for basic system piping configurations.
- Systems with automatic fill valves require back flow prevention device.
- Single boiler system. See Figures 5-4, 5-5, for general guidance. Additional considerations:
 - Boiler control is designed for single central heating pump. Installer responsible for integration of multiple central heating pumps.
 - Boiler control allows domestic hot water prioritization. Function could be lost if central heating pump is not directly connected to control system.
- Multiple boiler system. Considerations:
 - Control system requires equivalent water temperatures entering each boiler to properly sequence and adjust system supply temperature.

- Ensure washers supplied are utilized.
- Face valves and fittings to rear wall.
- Fit union bends to valves.
 - A. If soldering to boiler union bends, ensure bends are not connected to the valves, otherwise internal seals may be damaged.
 - B. Verify 3/4" [22.2 mm] isolating valve with filter is fitted to heating return connection.
 - C. Fit pressure relief valve connection vertically before heating isolating valve.
- Connect system valve pipe work to the boiler.
- Route pressure relief valve discharge piping to the floor. Follow local code with respect to necessary distance to the floor. See Figure 5-2.
- Verify all valves are closed.

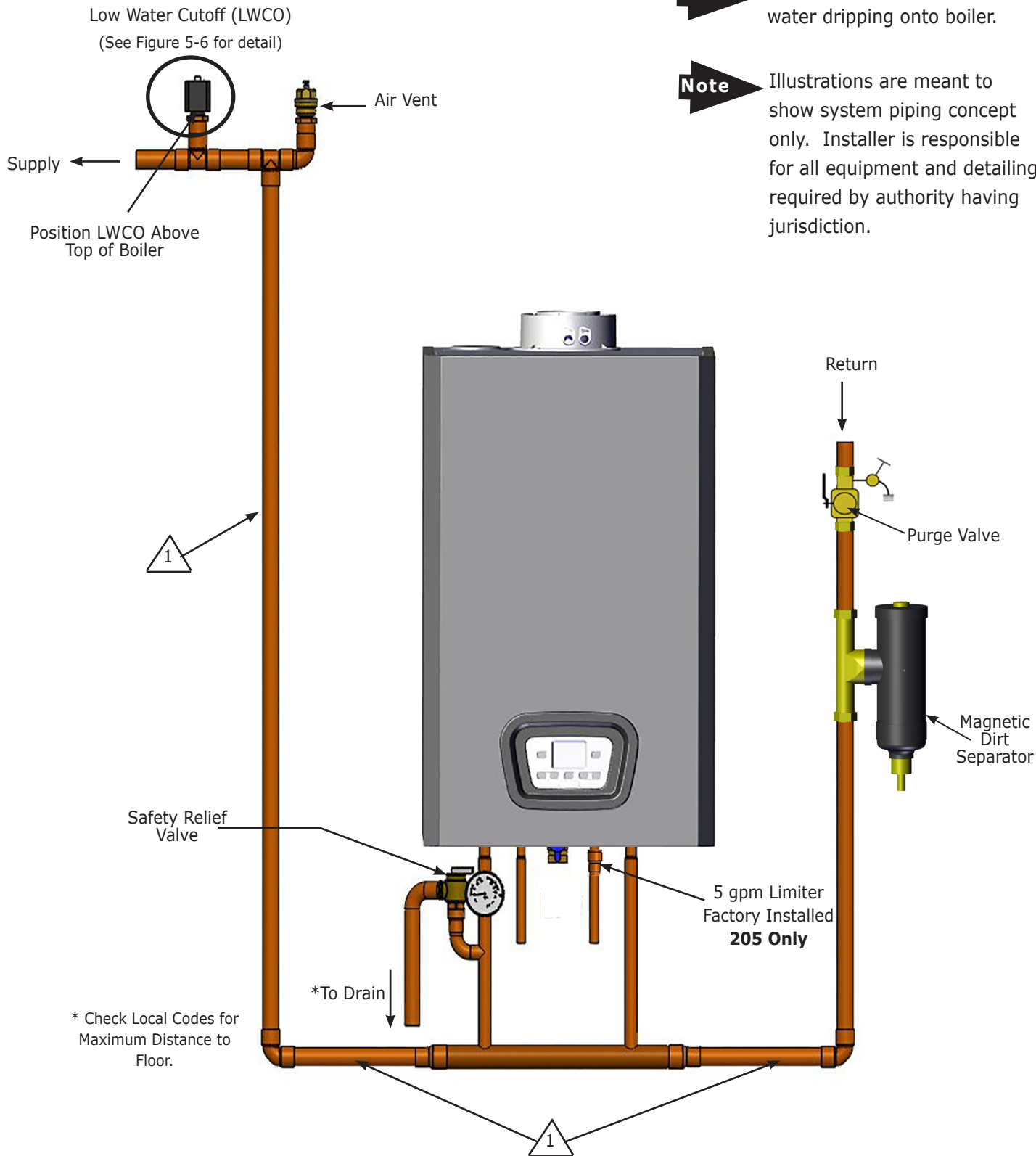
WARNING

Burn and scald hazard. Verify all plastic caps are removed from boiler connections. Failure to follow these instructions could result in death or serious injury.

- Thoroughly flush all hydronic piping.
- Secure all valves/fittings to boiler.

5 - HYDRONIC PIPING

FIGURE 5-3 - Piping Diagram - LWCO Location



Note Arrange piping to prevent water dripping onto boiler.

Note Illustrations are meant to show system piping concept only. Installer is responsible for all equipment and detailing required by authority having jurisdiction.

Note 1 DO NOT PLACE ISOLATION VALVE BEFORE TEE OR LWCO.

5.6 External Optional Low Water Cut Off

These guidelines are supplied when necessary to install an additional Low Water Cut Off (LWCO), for sensing a low water level condition in a boiler, as required by the Authority Having Jurisdiction.

Follow LWCO manufacturer installation instructions for type of LWCO selected in addition to these instructions.

LWCO shall be 120V/60HZ control and dry contacts sized for load being connected. Wire control to boiler. See Figure 5-4.

Connect LWCO device to the system ground. Ground in accordance with the requirements of the authority having jurisdiction or, in the absence of such requirements, with the National Electrical Code (NEC) or Canadian Electrical Code CEC.

- Locate LWCO sensing device in the supply piping, above the minimum height of boiler. See Figure 5-3, Piping Diagram.
- Position control in HORIZONTAL piping to assure proper boiler protection (upright or 90° rotation).
- For proper operation, sensing element of the LWCO control shall be positioned in the tee to sense the main water stream. Maintain minimum 1/4" spacing from pipe walls. Element shall NOT contact the rear, or side walls of the tee. See Figure 5-5.
- Install an air vent using a tee to avoid nuisance shutdowns.
- Apply small amount of pipe sealant to threaded connections.
- Arrange piping to prevent water dripping onto boiler.
- DO NOT install water shutoff valve between boiler and LWCO sensing device.

FIGURE 5-5 - Low Water Cutoff - Detail

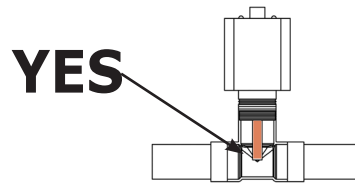
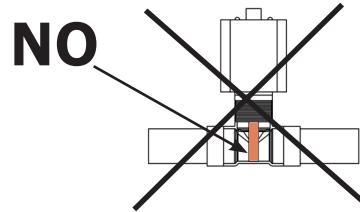
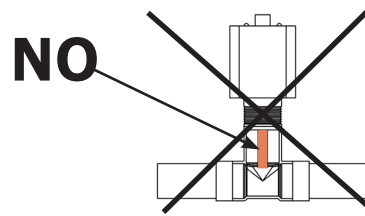
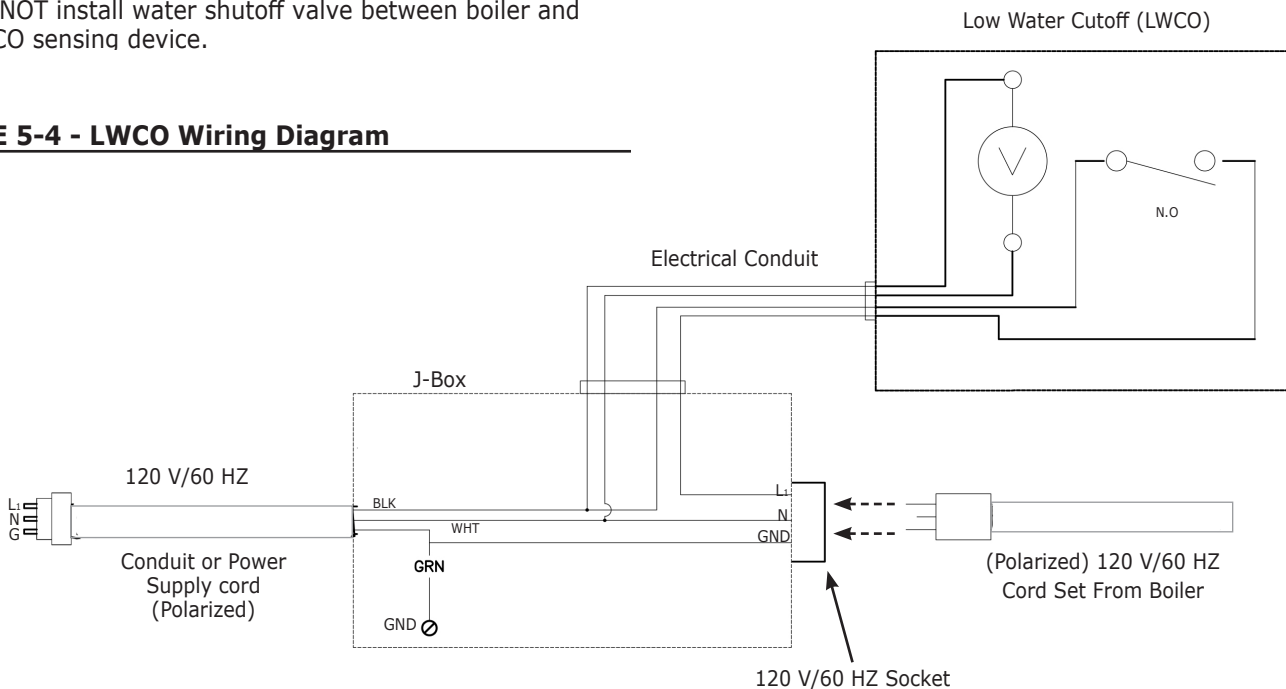
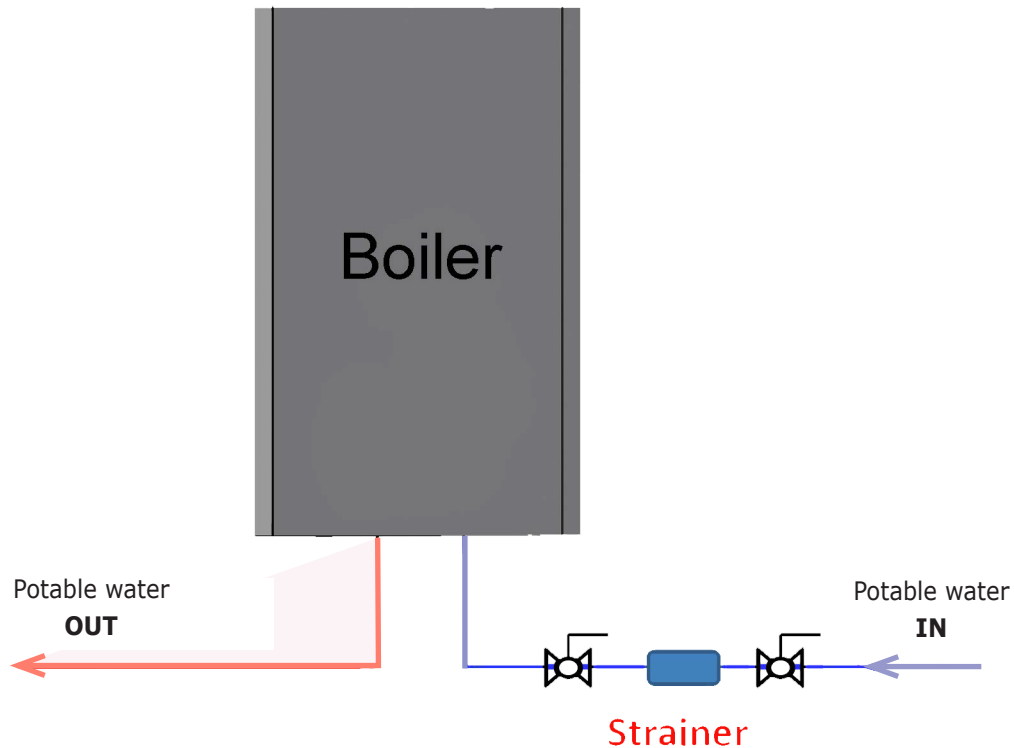


FIGURE 5-4 - LWCO Wiring Diagram



5.7 Manufacturer Recommendation - Strainer



Manufacturer Recommendation

A strainer filtering potable water before entering the boiler is highly recommended to prevent errors and lockouts. The strainer prevents any sedimentation and debris from your water supply piping from entering the boiler. Debris carried from the water supply will clog DHW water flow sensor resulting in error codes and causing boiler to lockout.

Locate the strainer as close to the boiler as possible and place on DHW (domestic hot water) inlet connection located at bottom of the boiler.

5 - HYDRONIC PIPING

5.8 Central Heating System

Boiler is designed for use in a sealed central heating system. Design the system to operate with flow temperatures of up to 176°F (80° C), take pump head, expansion tank size, mean radiator temperature, etc. into account.

Boiler is supplied with the following components: Pressure relief valve - 30.0 psi (2.1 bar). Boiler internal pressure switch will shut boiler off at 43.5 psi /3.0 bar.

Pressure gauge - to indicate the system pressure to be maintained.

By-pass - Boiler incorporates an automatic by-pass, However, where all radiators are fitted with thermostatic radiator valves, an external by-pass must be fitted.

5.9 Domestic Hot Water Mode

Utica Boiler MAC-150 & 205 and MAH-125 & 165 with indirect tank

WARNING

Burn, Scald Hazard! Water temperature over 125°F (51°C) can cause severe burns and scalding. See User's Manual before setting water temperature. Failure to follow these instructions could result in death or serious injury.

- Priority is given to the domestic hot water supply. Demand at tap or shower will override any central heating requirement.

- Flow of water will operate the DHW flow switch which requests the 3 way valve to change position. This will allow the pump to circulate the primary water through the DHW plate heat exchanger. (MAC-150 & 205 only)
- Combustion fan will then come on and begin to run at ignition speed.
- Once the fan reaches ignition speed the control board will allow power to flow to the spark generator and gas valve creating ignition in the combustion chamber. The flame sensor will acknowledge the presence of the flame in the combustion chamber and send a signal to the control board.
- Temperature sensors will send a signal to the control board allowing the control board to increase/ decrease the speed of the fan. The combustion fan will in turn modulate the gas rate accordingly.
- When the domestic hot water demand ceases the burner will extinguish, unless there is a demand for central heating.

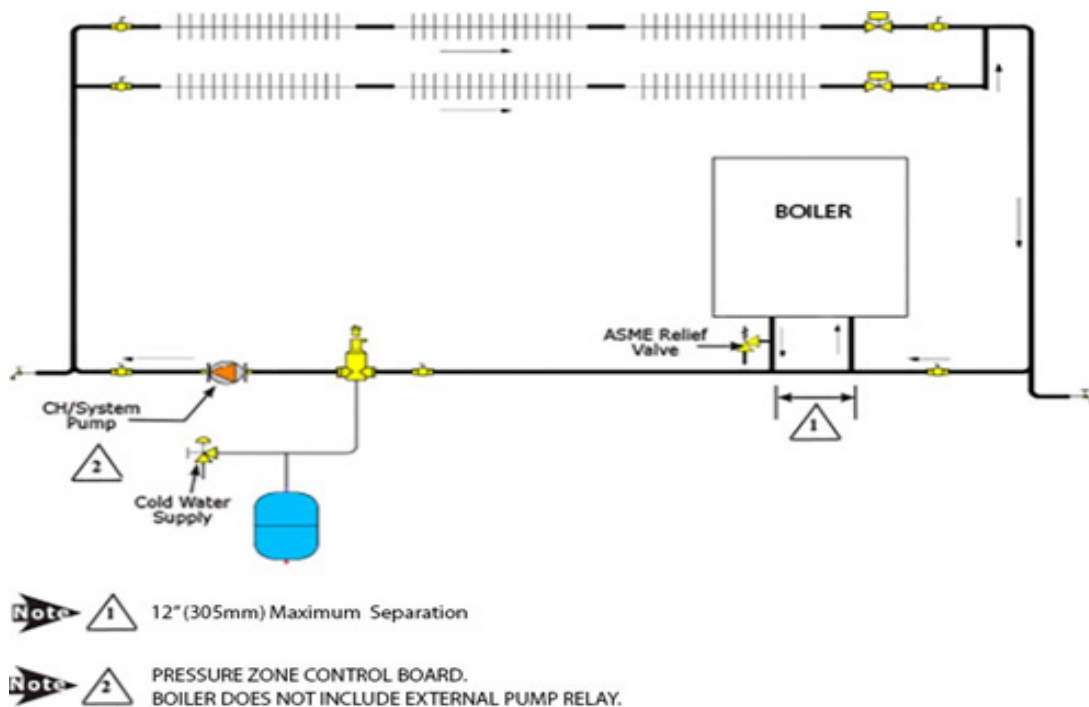
5.10 Frost Protection Mode

Frost protection mode is integrated into the appliance when left in domestic hot water or central heating position. If the temperature falls below 41°F / 5° C boiler will fire on its minimum setting until flow temperature of 86°F / 30° C is reached.

5.11 Pump Protection

Pump will automatically operate for 1 minute in every 24 hours to prevent seizing.

FIGURE 5-7



⚠ WARNING

Fire, explosion, and asphyxiation hazard. Improper installation could result in death or serious injury. Read these instructions and understand all requirements before beginning installation.

⚠ WARNING

ABS/PVC venting shall not be used this product. Use of DWV plumbing pipes to vent this boiler shall be prohibited. Use of cellular core PVC (ASTM F891), cellular core CPVC, or Radel® (polyphenolsulfone) in venting systems shall be prohibited. Covering non-metallic vent pipe and fittings with thermal insulation shall be prohibited. Failure to follow these instructions could result in death or serious injury.

Note

Follow venting manufacturer's equivalent lengths for specialty fittings.

6.1 General

- Installations shall comply with Authority having jurisdiction and in absence of such with:
 - » U.S. ANSI Z223.1 /NFPA 54 in the United States
 - » CSA B149.1 in Canada.
- This boiler requires a dedicated direct vent system.
- Vent connections serving appliances vented by natural draft shall not be connected into any portion of mechanical draft systems operating under positive pressure.
- Materials used in the U.S. shall comply with Authority having jurisdiction and in absence of such with: ANSI/ASTM D1785, ANSI/ASTM F441, ANSI/ASTF493, UL1738 or ULS636.
- Canadian installations only: All venting material, primer and glue must be listed to ULC S636.
- Venting system must be free to expand and contract.
- Vent system must have unrestricted movement through walls, ceilings and roof penetrations.
- Check for proper joint construction when joining pipe to fittings.
- If vent is penetrating ceilings and floors, openings must have means of fire stopping in joist areas and proper firestop spacer assemblies installed.
- Standard roof flashing methods must be used to install roof flashing.
- Frame wall and roof openings to provide support for attachment of termination assemblies.
- Support piping in accordance with pipe manufacturer's instruction and authority having jurisdiction. In absence of manufacturer's instruction use pipe hooks, pipe straps, brackets, or hangers of adequate and strength located at intervals of 3 ft (1.m) or less. Allow for expansion/contraction of pipe.
- Venting shall be supported adjacent to each joint using steel strapping or equivalent. See Figure 6-1.

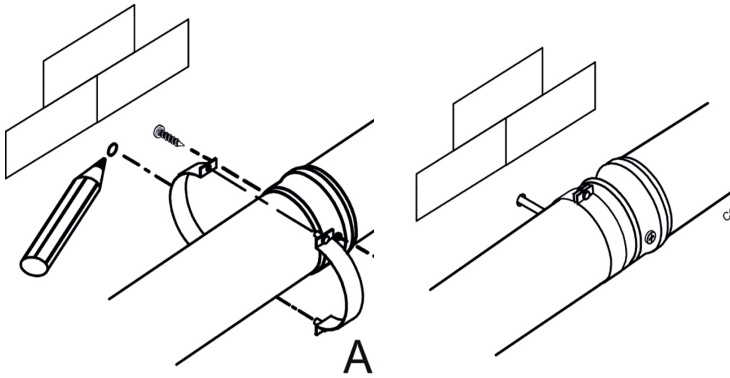
- Support horizontal sections of vent pipe to prevent sags capable of accumulating condensate.
- Assemble vent materials in accordance with venting manufacturer's instructions.
- Slope exhaust pipe minimum of 1/4" per foot, or vent manufacturer's recommendation, whichever is greater; back toward the boiler.
- Any "in line" elbows in flue system must be taken into consideration. First elbow on the top of the boiler is included in equivalent length calculations.
- Use U.V. stabilized polypropylene when it will be exposed to sunlight, wind, or prone to freeze ups.

6.2 Removal of Existing Boiler From Common Vent System

When existing boiler is removed from common venting system, common venting system is likely to be too large for proper venting of appliances remaining connected to it. After removal of existing boiler, following steps shall be followed with each appliance remaining connected to common venting system placed in operation, while other appliances remaining connected to common venting system are not in operation:

- Seal any unused openings in common venting system.
- Visually inspect venting system for proper size and horizontal pitch. Determine there is no blockage or restrictions, leakage, corrosion and other deficiencies which could cause an unsafe condition.
- When practical, close all building doors, windows, and all doors between space in which appliances remaining connected to common venting system are located and other spaces of building. Turn on clothes dryer and any appliance not connected to common venting system. Turn on exhaust fans, such as range hoods and bathroom exhaust so they will operate at maximum speed. Do not operate summer exhaust fan. Close fireplace dampers.
- Turn on appliance being inspected. Follow lighting instructions. Adjust thermostat so appliances will operate continuously.
- Test for spillage at draft hood relief opening after 5 minutes of main burner operation. Use flame of match or candle, smoke from cigarette, cigar or pipe.
- Determine each appliance remaining connected to common venting system properly vents when tested as outlined above. Then return doors, windows, exhaust fans and any other gas-burning appliance to their previous condition of use.
- Any improper operation of common venting system should be corrected so installation conforms with National Fuel Code, ANSI Z223.1/NFPA 54 and/or Natural Gas and Propane Installation Code, CAN/CSA B149.1. When re-sizing any portion of common venting system, common venting system should be re-sized to approach minimum size as determined using appropriate tables in Chapter 13 of the National Fuel Gas Code, ANSI Z223.1/NFPA 54 and/or Natural Gas and Propane Installation Code, CAN/CSA B149.1.

Figure 6-1 - Venting Support

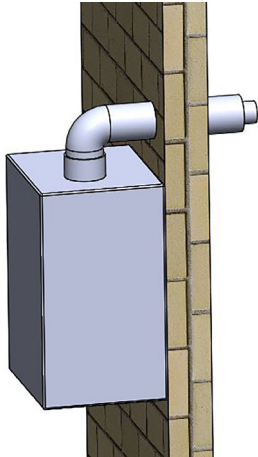


6.4 Securing Twin Pipe Polypropylene Venting

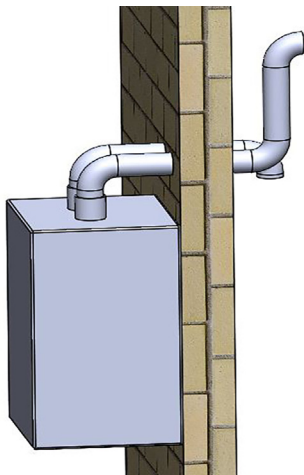
Note Venting manufacturer's use a device to secure single wall twin pipe polypropylene vent pieces to each other. Proper application of the securing mechanism is necessary for any use of twin pipe polypropylene venting on exhaust or air intake. Securing mechanism is for indoor use only and should not be used in outdoor applications. Follow venting manufacturer's instructions for applying the securing mechanism on twin pipe polypropylene venting.

6.3 Definitions

1. **Coaxial piping** - **Figure 6-2** exhaust and air intake pipe have a common axis.



2. **Twin Pipe** - **Figure 6-3** Exhaust and intake air are separate pipes, can be terminated using single wall terminals from the vent manufacturer or field built configuration using elbows or tees.

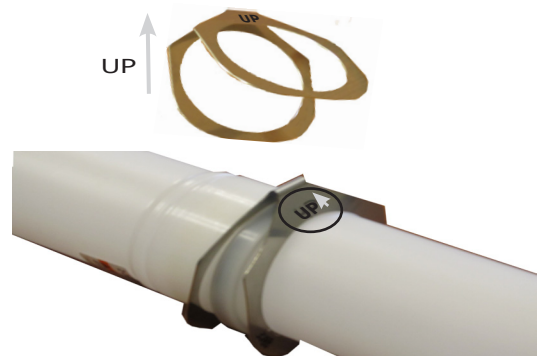


Example for Natalini venting system.

(For other venting system suppliers see their instructions.)

1. Place clamp so etched "UP" is facing up.
2. Open clamp slightly by separating circular areas from each other.
3. Slide male end of first pipe through open clamp so the shoulder of the female end of the pipe stops the clamp from sliding off the pipe.
4. Insert the male end of the second pipe into the clamp on the "up" etched side. Force the two pipes together.
5. Verify the two pipes are secure together with clamp in place.

Figure 6-4 - Natalini Clamp



6 - COMBUSTION AIR AND VENT PIPING

6.5 Approved Venting Materials

⚠ WARNING

Manufacturer recommends this condensing boiler be vented with approved polypropylene venting material. Use only materials listed below for vent pipe, intake air pipe, and fittings. Failure to comply could result in death or serious injury.

⚠ WARNING

- Covering non-metallic vent pipe and fittings with thermal insulation shall be prohibited.
- Use of cellular core PVC for venting flue gas could result in death, or serious injury.
- Coaxial venting shall be fastened with screws. Dual flue venting is NOT fastened with screws.

⚠ WARNING

Do not use cellular core pipe. Only specified sized pipes are to be used. When using venting material other than boiler manufacturer's venting, note the correct installation procedure. Failure to follow these instructions could result in death, or serious injury.

Installation shall conform to requirements of authority having jurisdiction or in absence of such requirements:

- USA - National Fuel Gas Code, ANSI Z223.1/NFPA 54.
- Canada - Natural Gas and Propane Installation Code, CAN/CSA B149.1

1. Venting shall be properly supported.

2. Boiler shall not support any type of vent system.
3. All piping, glue, solvents, cleaners, fittings and components must conform to ASTM and ANSI standards. In Canada ULC S636 and in the USA UL 1738 schedule 40 CPVC are the only approved vent system to be used as an alternative to polypropylene venting for the exhaust pipe
4. Manufacturer requires use of a spring clamp at every push-fit gasket connection when using a single wall polypropylene vent system.

6.6 Vent Termination

- Terminate combustion air and vent pipes with fittings or coaxial vent kit.
Use horizontal pipe for vent and 90° elbow for combustion air termination when using fittings.
- Separate vent terminal from air inlet terminal to prevent flue gas recirculation. If T-Terminal is used on flue pipe at sidewall, air inlet terminal shall be at least 36" or more away from vent terminal.
- Locate combustion air termination as far as possible from swimming pool, swimming pool pump house, and other sources of airborne chlorine.
- Locate combustion air and vent terminals as required by authority having jurisdiction.

Approved Polypropylene Manufacturers

- * Natalini
- * DuraVent®
- * Centrotherm
- * Z-Flex®

Note: Maximum equivalent length may vary between manufacturers.

Vent Material Options					
125 & 150			165 & 205		
1	4" / 2" [100 mm / 50 mm] polypropylene coaxial.		1	5"/3" [125mm/80m] polypropylene coaxial.	
2	3" [80mm] polypropylene twin pipe. Shall be polypropylene on BOTH intake and exhaust.		2	3" [80mm] polypropylene twin pipe. Shall be polypropylene on BOTH intake and exhaust.	
3	3" [80mm] flexible polypropylene for chimney exhaust vent, shall have rigid 3" [80mm] polypropylene on air intake.		3	2" [50mm] polypropylene twin pipe. Shall be polypropylene on BOTH intake and exhaust.	
4	3" [80mm] Twin pipe CPVC. PVC optional on intake ONLY.		4	3" [80mm] flexible polypropylene for chimney exhaust vent, shall have rigid 3" [80mm] polypropylene on air intake.	
			5	3" [80mm] Twin pipe CPVC. PVC optional on intake ONLY.	
* Note: Adapters and fittings used with all vent systems shall be from same manufacturer and compatible with the vent pipe. See list for approved Manufacturers.					

6 - COMBUSTION AIR AND VENT PIPING

6.7 Coaxial Venting Instructions

Maximum equivalent flue lengths for Coaxial venting are:

Coaxial Pipe Maximum Vent Lengths		
Boiler Size	125/150	165/205
Vent Size	4"/2" [100mm/50mm]	5"/3" [128mm/80mm]
Natalini	32.80 ft [10m]	32.80 ft [10m]
DuraVent®	27.88 ft [8.5m]	32.80 ft [10m]
Centrotherm	24.60 ft [7.5m]	32.80 ft [10m]

Coaxial Elbows - Equivalent length	
4"/2" [100mm/60mm]	
45°	1.64 ft. [0.5m]
90°	3.28 ft. [1.0m]
5" / 3" [128mm/80mm]	
45°	1.64 ft. [0.5m]
90°	3.28 ft. [1.0m]

NOTE: Coaxial venting can run horizontal or vertical.

- Connect flue elbow to top of boiler and adjust direction of elbow to desired orientation (rear, right or left).
- Measure distance from outside wall face to elbow, this dimension will be known as "X", add distance "Y" + 2" (50mm) to "X" this is the total dimension of the vents. See Figure 6-6.
- Mark dimension from above on outer aluminum intake vent. Measure length of waste material, and transfer dimension to inner grey flue pipe.
- Remove waste from both vents (flue and air). Verify cut ends are square and free from burrs. Insert flue back into intake air vent and pass them through hole in wall.
- Check all measurements before cutting. Clearance to combustible materials is zero when using coaxial vent system.
- After installing venting use calibrated analyzer to verify there is no recirculation of combustion.
- Ensure termination is positioned with slots at the bottom.

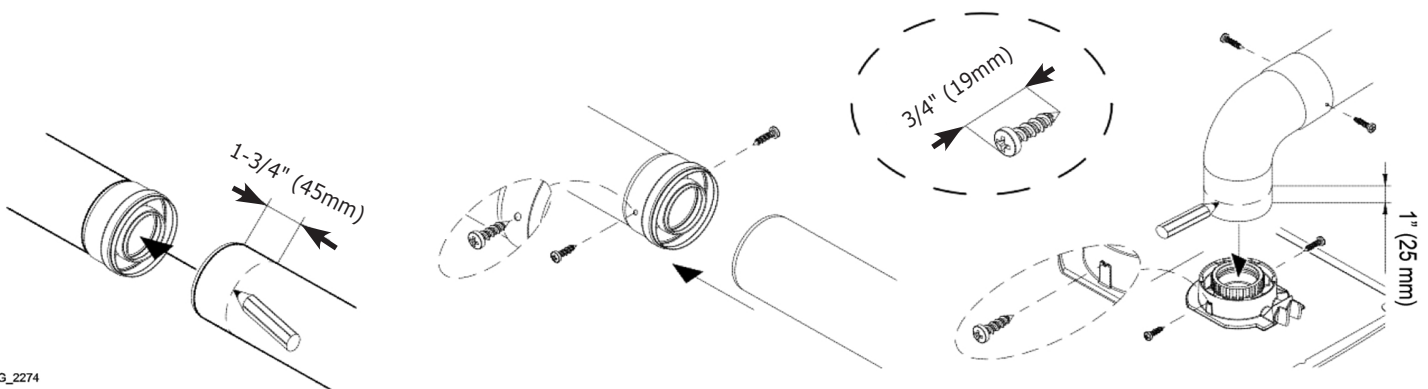
⚠ WARNING

Asphyxiation hazard. Before securing the screws ensure the pipe has been pushed in a minimum of 1-3/4" (45mm) into the gasketed end of the the other pipe. Failure to follow these instructions could result in death or serious injury.

6.8 Coaxial Vent Screw Placement - See Figure 6-5

Two (2) screws shall be fastened through the outer intake pipe behind the gaskets at equal distances, approximately 180° apart. Note the screws used must be no larger than No. 8-1/2 sheet metal screws and must be zinc coated. The length of the screws must be 3/4" (19.00mm).

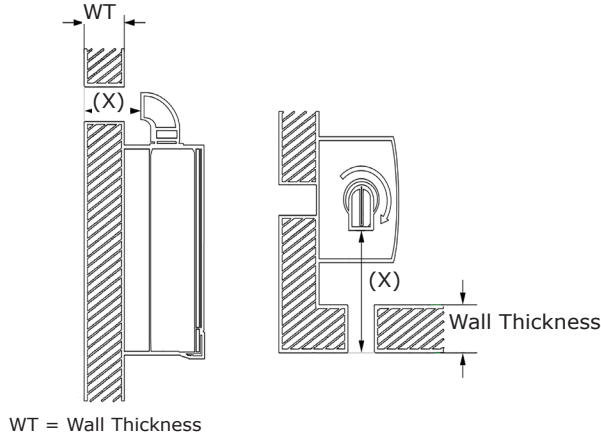
Figure 6-5 - Coaxial Screw Placement



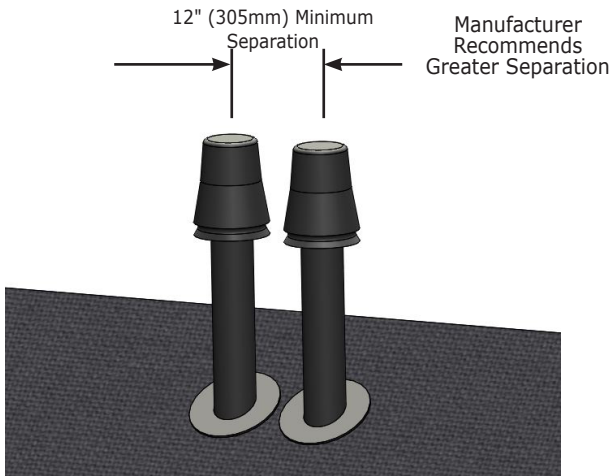
CG_2274

6 - COMBUSTION AIR AND VENT PIPING

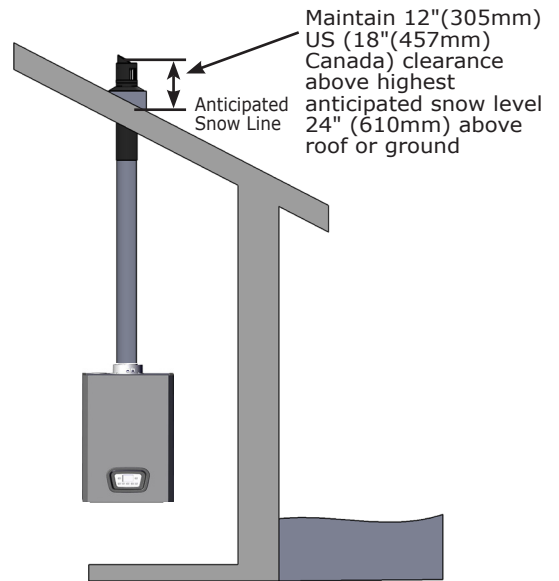
**FIGURE 6-6 - Coaxial Venting Horizontal or Vertical
CAN BE USED ON ALL SIZES**



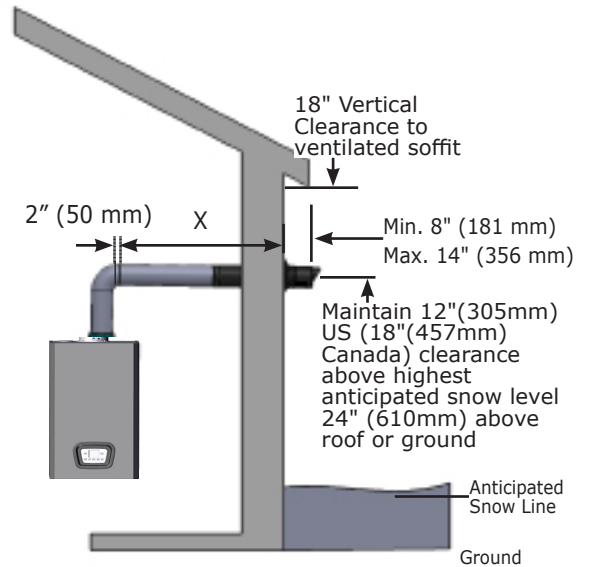
**FIGURE 6-7 - Coaxial Vertical Exhaust
CAN BE USED ON ALL SIZES**



**FIGURE 6-8 Roof Mount Coaxial Venting
CAN BE USED ON ALL SIZES**



**FIGURE 6-9 Side Wall Coaxial Venting
CAN BE USED ON ALL SIZES**



6 - COMBUSTION AIR AND VENT PIPING

6.9 Twin Pipe Systems

Twin pipe venting allows exhaust flue and intake flue to be separated from each other. Fresh air is drawn in at a different area from the flue terminal location.

A. Twin Pipe CPVC System

CPVC is approved for boiler exhaust. CPVC or PVC are both approved for air intake.

To transition from Coaxial at the top of the boiler to Twin Pipe CPVC/PVC a kit is available.

B. Twin Pipe Polypropylene System

Single wall polypropylene is used for both exhaust and air intake piping.

To transition from Coaxial at the top of the boiler to Twin Pipe polypropylene venting an adapter kit is available.

C. Twin Pipe Separated Flue

Exhaust and combustion air intake are not located in same general location.

D. Twin Pipe - Common Atmospheric Zone Termination

Exhaust and combustion air intake are located in same general location and are of equal length.

Twin Pipe Maximum Vent Lengths - Separated Flue

		125/150		165/205	
		3" [80 mm]	2" [50 mm]	3" [80 mm]	2" [50 mm]
Intake Vent	L1	49 ft	85 ft	100 ft	85 ft
Exhaust Vent	L2	147 ft	85ft	100 ft	85 ft
Combined Vent	L1+L2	196ft	170 ft	200 ft	170 ft

Single Wall Elbows - Equivalent Length

	3"	2"
45° bend	0.82 ft [0.25 m]	3 ft [0.91m]
90° bend	1.64 ft [0.50 m]	5 ft [1.5 m]

NOTE: Two pipe separated flue can run horizontal or vertical.

FIGURE 6-10 - 2" & 3" Twin Pipe Separated Horizontal Flue Termination - ONLY USE ON 165/205

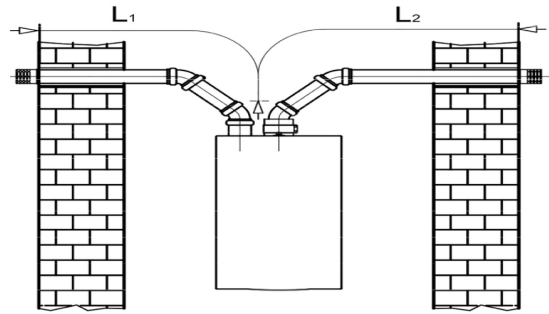


FIGURE 6-11 - 2" & 3" Twin Pipe Separated Horizontal Flue Termination With Tee On Exhaust - CAN BE USED ON ALL SIZES

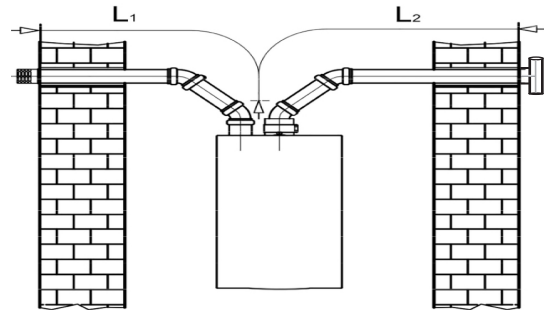
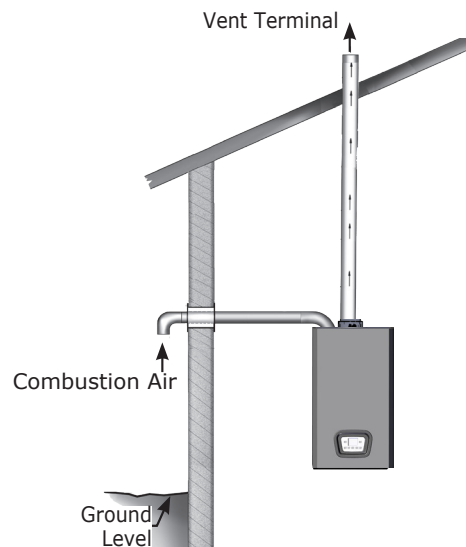


FIGURE 6-12 - Twin Pipe on Roof Combustion Air On Sidewall CAN BE USED ON ALL SIZES



6 - COMBUSTION AIR AND VENT PIPING

Twin Pipe Maximum Vent Lengths Terminating in same location		
125/150	165/205	
3" [80 mm]	3" [80 mm]	2" [50 mm]
49 ft	100 ft	85 ft

Single Wall Elbows - Equivalent Length

Polypropylene

	3"	2"
45° bend	0.82 ft [0.25 m]	3 ft. [0.91m]
90° bend	1.64 ft [0.50 m]	5 ft [1.5 m]

PVC/CPVC

	3"
45° bend	3.5 ft [1 m]
90° bend	5.0 ft [1.50 m]

Note: Twin Pipe Common Atmospheric Zone termination can be run horizontal or vertical

FIGURE 6-13 - Twin Pipe Flue On Sidewall, Combustion Air On Roof CAN BE USED ON ALL SIZES

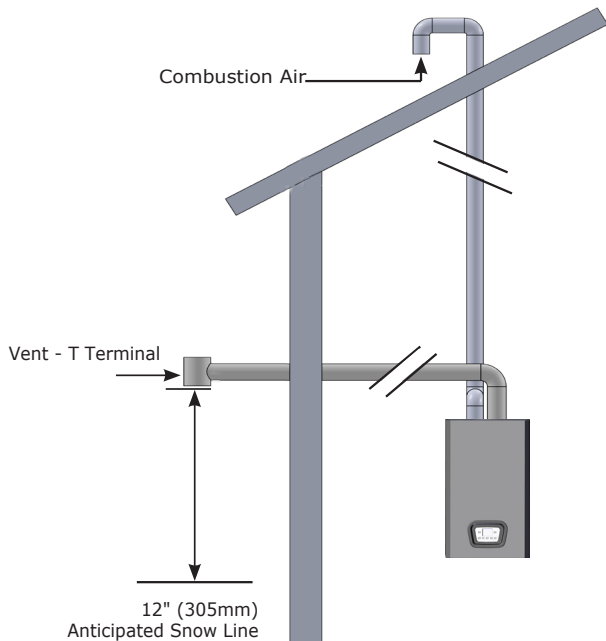


FIGURE 6-14 - (2" & 3") Twin Pipe Roof Vent CAN BE USED ON ALL SIZES

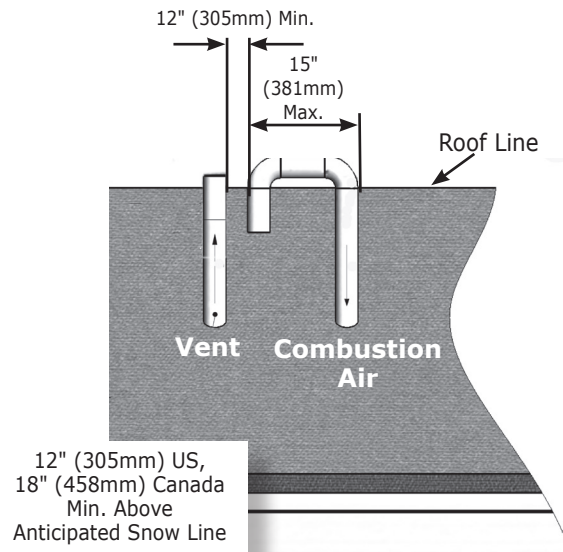


FIGURE 6-15 -Twin Pipe Side Wall Vent (Multiple Appliances) (CAN BE USED ON 165 & 205 ONLY)

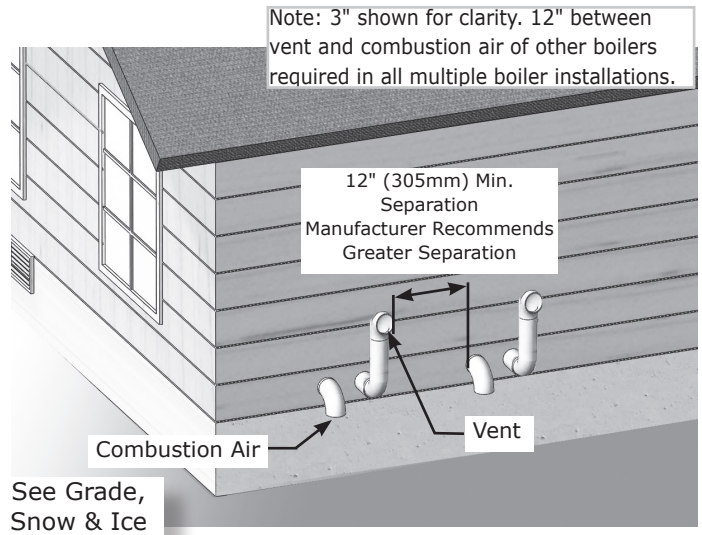
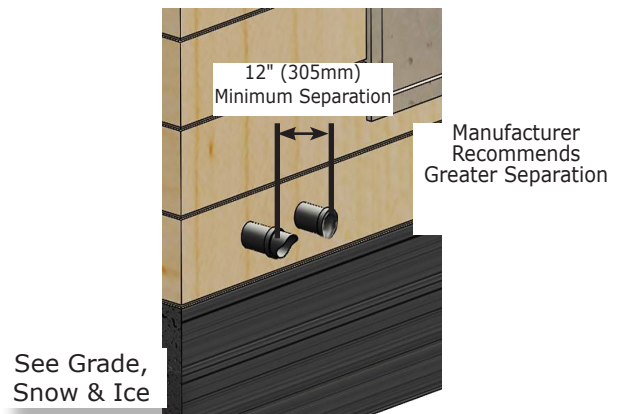


FIGURE 6-16 - (3" ONLY) Horizontal Twin Pipe, Exhaust and Intake (CAN BE USED ON 165 & 205 ONLY)



6 - COMBUSTION AIR AND VENT PIPING

FIGURE 6-17 - (3" ONLY) Twin Pipe Side Wall Vent (CAN BE USED ON 165 & 205 ONLY)

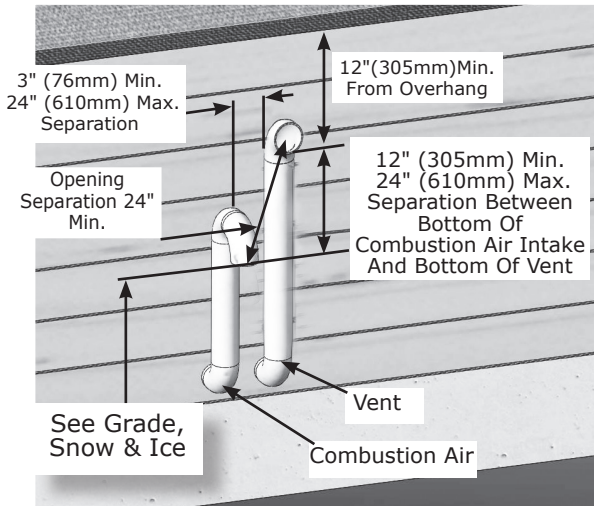


FIGURE 6-19 - (3" ONLY) Single Wall Exhaust Kit and Air Intake Minimum Distance Center to Center (CAN BE USED ON 165 & 205 ONLY)

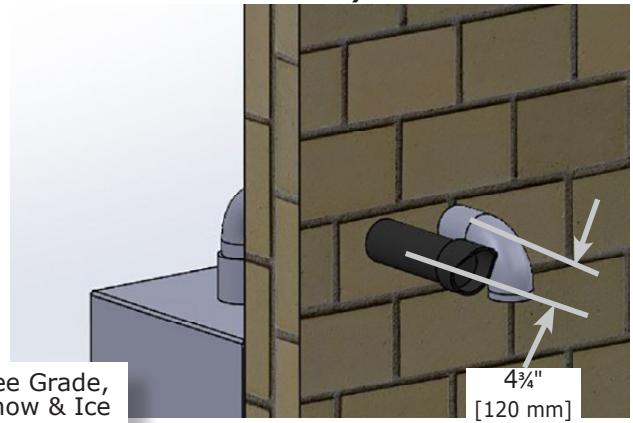


FIGURE 6-20 - (2" ONLY) Twin Pipe Side Wall Vent CAN BE USED ON ALL SIZES

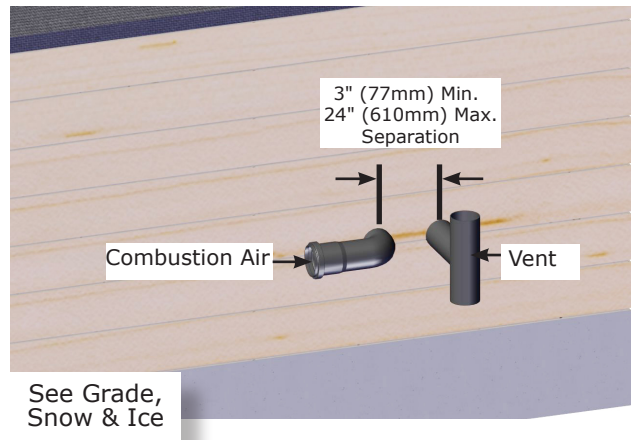
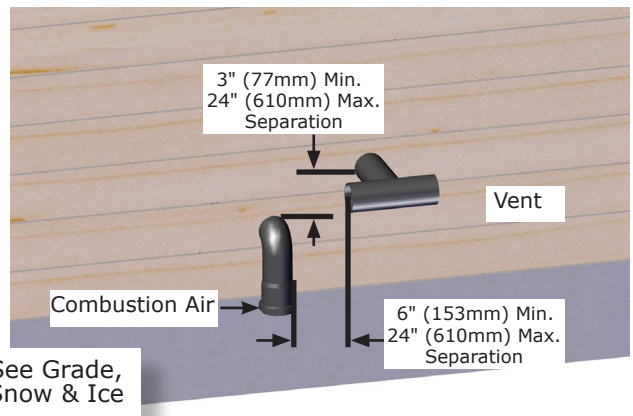
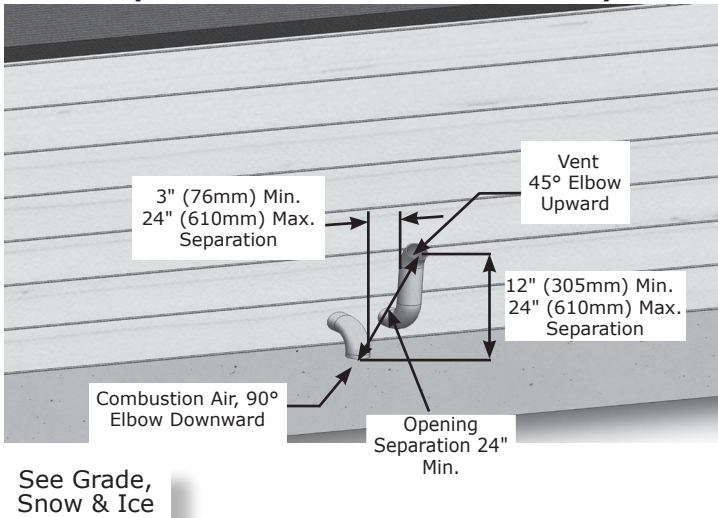


FIGURE 6-21 - (2" ONLY) Vent Pipe CAN BE USED ON ALL SIZES



Roof Terminations	<ul style="list-style-type: none"> • 12" (305mm) Min. horizontal separation between combustion air intake and vent of same appliance. • 12" (305mm) Min. 84" (2.2m) Max. vertical separation between combustion air intake and vent of different appliances. • 15" (381mm) Max. horizontal length of vent. • Min. vent/intake between different appliances 12" (305mm). • Max. allowable total vertical vent length with outside exposure is 10 ft.(3.05m). • Abandoned unused masonry chimney may be used as chaseway for combustion air and vent. Both combustion air and vent pipe must exit above top of chimney with clearances as shown in Figure 6-14.
--------------------------	---

FIGURE 6-18 - (3" ONLY) Twin Pipe Side Wall with 45° Vent (CAN BE USED ON 165 & 205 ONLY)



Grade, Snow & Ice	<p>Maintain 12"(305mm) US, 18"(457mm) Canada clearance above highest anticipated snow level, 24" (610mm) above roof.</p> <p>Avoid locations where snow may drift and block vent and combustion air. Ice or snow may cause boiler to shut down if vent or combustion air becomes obstructed.</p>
------------------------------	---

6.10 (3" Only) Flexible Vent System

**FIGURE 6-22 - (3" Only) Flexible Venting System
CAN BE USED ON ALL SIZES**

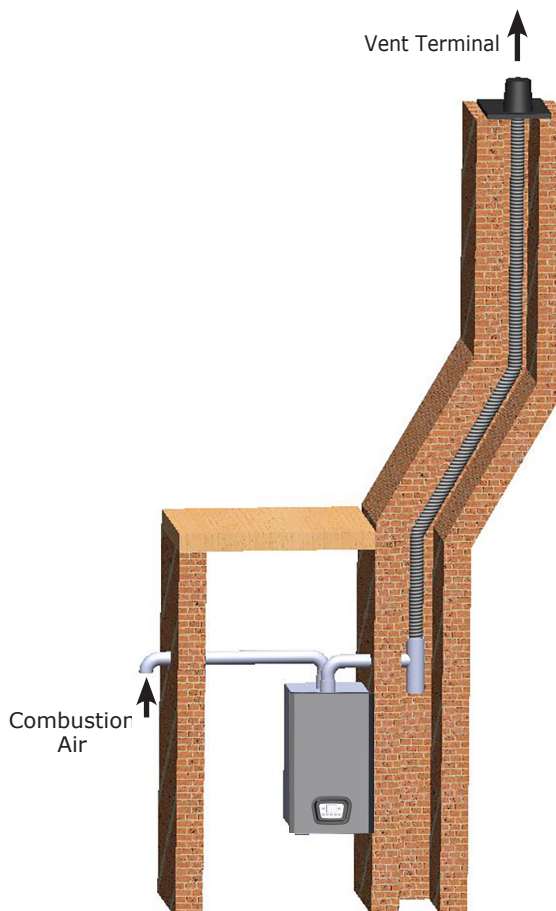
Flexible Pipe Maximum Vent Lengths			
3" [80 mm] Diameter Pipe		125/150	165/205
Natalini	Exhaust	75 ft [22.8m]	50 ft [15.2m]
	Intake	50 ft [15.2m]	50 ft [15.2m]
DuraVent®	Exhaust	82 ft [24.9m]	50 ft [15.2m]
	Intake	50 ft [15.2m]	50 ft [15.2m]
Centrotherm	Exhaust	52 ft [15.8m]	50 ft [15.2m]
	Intake	50 ft [15.2m]	50 ft [15.2m]
Z-Dens	Exhaust	NA	50 ft [15.2m]
	Intake		50 ft [15.2m]

Single Wall Elbows - Equivalent Length

	3" [80 mm]
45° bend	0.82 ft [0.25 m]
90° bend	1.64 ft [0.50 m]

Note Flexible vent systems shall only be run vertical. Horizontal runs before adapting to flexible must be rigid pipe.

- Maximum vent lengths based on equivalent straight runs only. Include rigid pipe and fittings in overall equivalent length calculations.
- Flexible venting installations use single wall polypropylene to pass flue gasses to base of chimney, then flexible venting to get them to termination at the top.
- Combustion air is not supplied through masonry chimney. Combustion air must be from outside using 3" [80 mm] single wall polypropylene.
- Position boiler to use minimum of rigid single wall polypropylene venting to the chimney.
- Follow venting manufacturer's instructions on assembly and clearances to maintain.
- Avoid sharp bends in flexible venting.



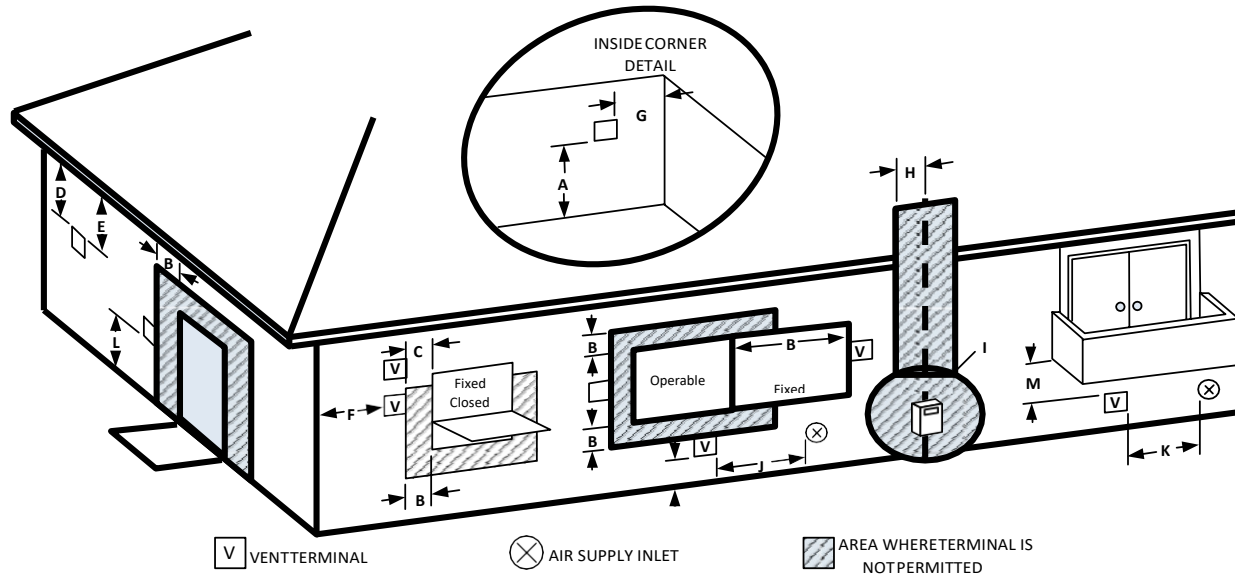
6 - COMBUSTION AIR AND VENT PIPING

FIGURE 6-23 - Flue Terminal Location

All vent pipe and combustion air pipe and fittings shall comply with the following:

Materials used in the U.S. must comply with the following standards:

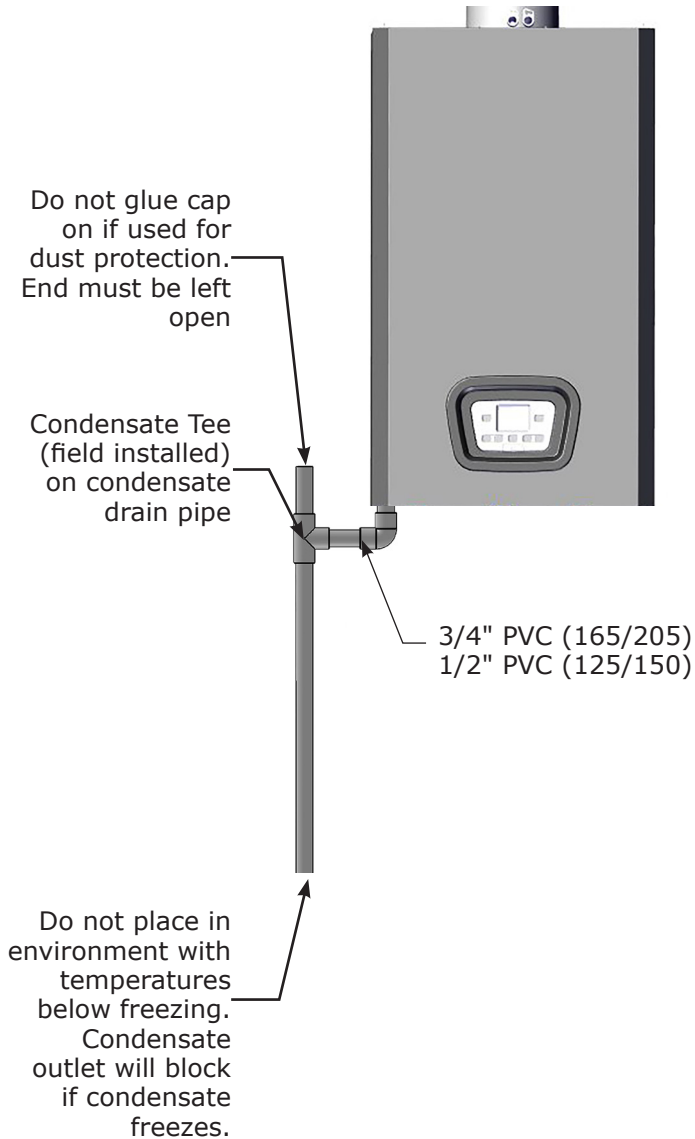
ANSI/ASTM D1785, ANSI/ASTMD2661, ANSI/ ASTM F441.



Vent Termination Minimum Clearances			
		US Installations	Canadian Installations
A	Clearance above grade, veranda, porch, deck, or balcony	12" (305mm)	12" (305mm)
B	Clearance to window or door that may be opened	12" (305mm)	3 ft. (0.9m)
C	Clearance to permanently closed window	*12" (305mm)	*12" (305mm)
D	Vertical Clearance to ventilated soffit located above the terminal within a horizontal distance of 2 feet (610 mm) from the center line of the terminal	18" (457mm)	18" (457mm)
E	Clearance to unventilated soffit	18" (457mm)	18" (457mm)
F	Clearance to outside corner	9" (229mm)	9" (229mm)
G	Clearance to inside corner	36" (456mm)	36" (456mm)
H	Clearance to each side of center line extended above meter/ regulator assembly	3 ft. (0.9m) within a height of 15 ft. (4.5m) above the meter/ regulator assembly	3 ft. (0.9m)
I	Clearance to service regulator vent outlet	3 ft. (0.9m)	3 ft. (0.9m)
J	Clearance to non-mechanical air supply inlet to building or the combustion air inle to any other appliance	12" (305mm)	3 ft. (0.9m)
K	Clearance to mechanical air supply inlet	*3 ft. (0.9m)	6 ft. (1.8m)
L	Clearance above paved sidewalk or paved driveway located on public property	*7 ft. (2.1m)	7 ft. (2.1m) †
M	Clearance under veranda, porch, deck or balcony	*12" (305mm) ‡	12" (305mm)‡
† A vent shall not terminate directly above a sidewalk or paved driveway that is located between two single family dwellings and serves both dwellings.		*For clearances not specified in ANSI Z223.1/NFPA 54 or CSA B149.1, clearance will be in accordance with local installation codes and the requirements of the gas supplier and these installation instructions.	
‡ Permitted only if veranda, porch, deck or balcony is fully open on a minimum of one side beneath the floor.			

Note: Local Codes or Regulations may require different clearances. Flue terminal must be exposed to external air and position must allow the free passage of air across it at all times. In certain weather conditions the terminal may emit a plume of steam. Avoid positioning terminal where this may cause a nuisance.

FIGURE 6-24 - Condensate Drain



6.11 Condensate Piping

- Use materials acceptable to authority having jurisdiction. In absence of such authority:
 - USA - PVC or CPVC per ASTM D1785/D2845 Cement or primer per ASME D2564 or F493.
 - Canada - CSA or ULC certified PVC/CPVC pipe, fittings and cement.
- No external trap needed.
- Connect condensate hose, hose clamps, and coupling to boiler drain trap as shown in figure 6-24.
- Connect condensate piping to 3/4" PVC for 165/205 or 1/2" PVC for 125/150 as shown.
- Slope condensate drain pipe minimum 1/4" per foot (21mm/m) away from boiler.
- Support condensate pipe to eliminate any sags.
- Use field source condensate pump, designated for use with condensing boiler, if boiler located below disposal point.
- Condensate pump should have overflow switch. Condensate from Boiler is slightly acidic and may cause property damage if overflow.
- Field source condensate neutralizing kit as required by authority having jurisdiction or for environmentally friendly condensate disposal.

NOTICE

Manufacturer requires an air vent be used to prevent condensate line vacuum lock.

7 - GAS SUPPLY PIPING

WARNING

Fire, explosion, asphyxiation and burn hazard. Boiler piping and gas connections shall be leak tested before placing boiler in operation. Failure to follow these instructions and or improper installation could result in death or serious injury.

CAUTION

WHAT TO DO IF YOU SMELL GAS

- Do not try to light any appliance.
- Do not touch any electrical switch; do not use any phone in your building.
- Immediately call your gas supplier from a neighbor's phone. Follow gas supplier's instructions.
- If you cannot reach your gas supplier, call the fire department.

DANGER

Fire Hazard. Do not use matches, candles, open flames, or other methods providing ignition source. Failure to comply will result in death or serious injury.

WARNING

If overheating occurs or gas supply fails to shut off, do not turn off or disconnect the electrical supply to the pump. Shut off gas supply at a location external to the appliance. Do not use this boiler if any part has been under water. Call a qualified service technician before use.

NOTICE

Sediment trap shall be located upstream of gas controls.

7.1 General

- Use piping materials and joining methods acceptable to authority having jurisdiction. In absence of such requirements:
 - USA - National Fuel Gas Code, ANSI Z223.1/NFPA 54
 - Canada - Natural Gas and Propane Installation Code, CAN/CSA B149.1
- Install manual main shutoff valve before the gas valve accordance with state and local requirements.
- Size and install gas piping system to provide sufficient gas supply to meet maximum input at not less than minimum supply pressure.
 - A. MAH-125 requires a gas rate of 137.60 ft³/h (3.90 m³/h) for Gas A (Natural Gas) and 101.30 ft³/h (2.87 m³/h) for Gas E (Liquid Propane Gas).
 - B. MAC-150 requires a gas rate of 167.20 ft³/h (4.74 m³/h) for Gas A (Natural Gas) and 122.80 ft³/h (3.48 m³/h) for Gas E (Liquid Propane Gas).
- Gas meter and supply pipes must be capable of delivering the listed quantity of gas in addition to demand from any other appliances in the house. Boiler requires a 3/4" (19.5 mm) gas supply pipe.
- Support piping with hooks straps, bands, brackets, hangers, or building structure components to prevent or dampen excessive vibrations and prevent strain on gas connection. Boiler will not support piping weight.
- Use thread (joint) compound (pipe dope) suitable for liquefied petroleum gas.
- Install external field sourced manual main gas shutoff valve, ground joint union, and sediment trap upstream of gas controls.
- Install boiler so gas ignition system components are protected from water dripping, spraying, rain, etc. During appliance operation and service.
- Leak test boiler and gas line connections before placing boiler into operation.

7.2 Leak Check Gas Piping

Pressure test boiler and gas connection before placing boiler in operation.

- Pressure test over 1/2 psig (3.5 kPa). Disconnect boiler and its individual gas shutoff valve from gas supply system.
- Pressure test at 1/2 psig (3.5 kPa) or less. Isolate boiler from gas supply system by closing manual gas shutoff valve.
- Locate leakage using gas detector, noncorrosive detection fluid, or other leak detection method acceptable to authority having jurisdiction. Do not use matches, candles, open flames, or other methods that can provide ignition source.
- Correct leaks immediately and retest.

NOTICE

If overheating occurs or gas supply fails to shut off, do not turn off or disconnect electrical supply to pump. Shut off gas supply at location external to the boiler.

8 - ELECTRICAL CONNECTIONS

⚠ DANGER

Electrocution Hazard! HIGH VOLTAGE - Connections in terminal block M1 are high voltage (120V / 60Hz). Before making connections, verify appliance is disconnected from power supply. Respect the input polarity on terminal block M1: L (LINE) - N (NEUTRAL). Failure to follow these instructions WILL result in death or serious injury.

⚠ WARNING

Electrical shock hazard. Turn OFF electrical power supply at service panel before making electrical connections. Failure to do so could result in death or serious injury.

Model Size	125	150	165	205
Power Supply	120V - 60Hz			
Power Consumption	133 W	142 W	173 W	182 W
Internal Fuse (Qty. 2)	F3.15 A			
Electrode Spark Gap	1/8" to 3/16" [3.1mm to 4.7mm]			

Note

Wiring diagrams can be found in Appendix A of this Manual.

8.1 General

Electrically bond boiler to ground in accordance with requirements of authority having jurisdiction. Refer to:

- USA- National Electrical Code, ANSI/NFPA 70.
- Canada - Canadian Electrical Code, Part I, CSA C22.1: Safety Standard for Electrical Installations.
- Install all wiring in accordance with requirements of National Electrical Code and any additional national, state, or local code requirements having jurisdiction.
- In Canada, installation must conform to CSA C22.1 Canadian Electrical Code Part 1 and any local codes.
- All wiring shall be N.E.C. Class 1.
- Boiler shall be electrically grounded in accordance with the National Electrical Code, ANSI/NFPA No. 70-latest edition.
- Boiler requires a 120V 60Hz power supply. Ensure electrical supply is polarized.
- There shall only be one common isolator, providing complete electrical isolation, for boiler and any external controls. Using PVC insulated cable 12 AWGx3C 221°F (105 °C).

8.2 Install Room Thermostat

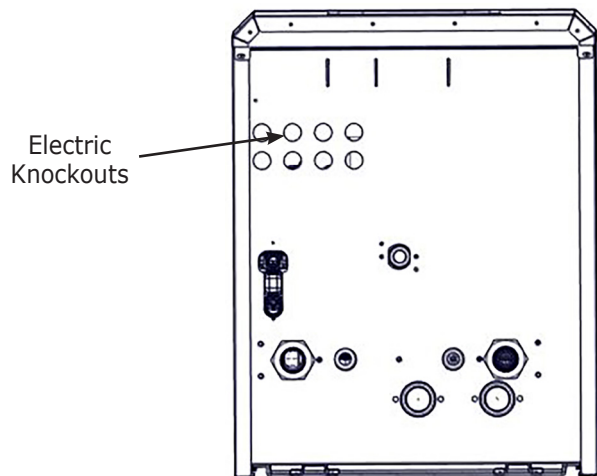
Install room thermostat on inside wall. Do not install where it will be influenced by drafts, hot or cold water pipes, lighting fixtures, television, sunrays or near a fireplace.

8.3 Electrical Connections

- Boiler requires 120V 60Hz power supply. Verify electrical supply is polarized.
- Boiler shall be grounded and on dedicated circuit.
- Shall be one common isolator, providing electrical isolation for boiler and any external controls. Using PVC insulated cable 18 AWGx3C 221°F (105°C).
- All wiring must be installed in accordance with requirements of the National Electrical Code and any additional national, state, or local code requirements having jurisdiction. All wiring must be N.E.C. Class 1.
- Canada, installation must conform to CSA C22.1 Canadian Electrical Code Part 1 and any local codes.
- If replacing original boiler wiring use only TEW 105°C or equivalent.
- If appliance is connected to in floor system, install limit thermostat to prevent latter from overheating.

FIGURE 8-1 Electric Knockouts Bottom Of Boiler -

Illustration shown (size 205), illustration is for location purposes, wiring knockouts found same general location on all sizes.



8 - ELECTRICAL CONNECTIONS

⚠ DANGER

Electrocution Hazard! HIGH VOLTAGE - Connections in terminal block M1 are high voltage (120V / 60Hz). Before making connections, verify appliance is disconnected from power supply. Respect the input polarity on terminal block M1: L (LINE) - N (NEUTRAL). Failure to follow these instructions WILL result in death or serious injury.

8.4 Access To Connection Block

1. Ensure there is no line voltage at boiler.
2. Unscrew two screws located under front panel. Remove front cover.
3. Guide controller or thermostat wire through round grommet(s) on right side of boiler's bottom plate right.
4. Tilt control box forward by opening holding clips located on left side of boiler.
5. Expose M1 and M2 terminal blocks by removing screw from plastic cover on left. See Figure 8-3.
6. Remove plastic from channel in plastic cover. Run wires through new opening.
7. Connect wires to appropriate terminals on connection block.
8. Tilt control box back to original position. Ensure clip on left side is fully engaged.
9. Replace front cover and screws under front panel.
10. Turn power to boiler on.

Various thermostats and controllers can be connected to standard control PCB.

8.5 Main Supply Connection


Main supply is connected to terminal block **M1** which is high voltage (120V / 60Hz).

Fuses, 3.15 A, are incorporated in the power supply terminal block. To check or replace fuse pull out black fuse carrier.

TERMINAL BLOCK M1

(L) = Live (brown)

(N) = Neutral (light blue).

 = Ground (yellow-green).

(1) (2) = contact for 120V Room Thermostat.

Place jumper back on terminals 1-2 of boiler terminal block **M1** if room thermostat is not used or if Remote Control is not installed.

FIGURE 8-2 Terminal Block Locations

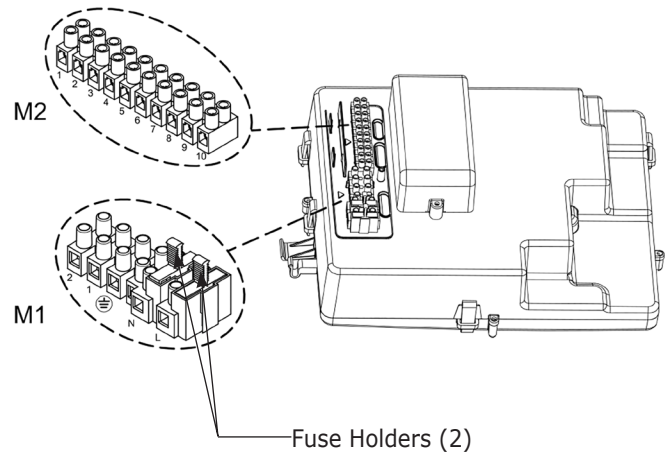
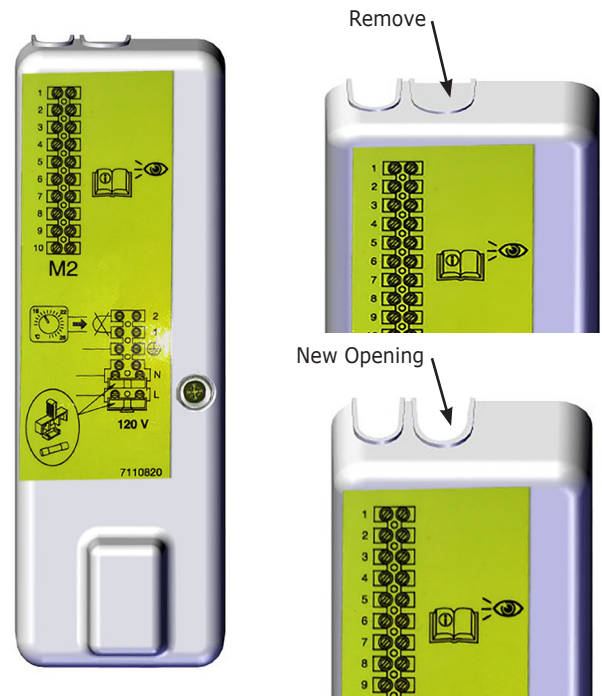


FIGURE 8-3 Terminal Plastic Cover with Knockouts



TERMINAL BLOCK M2

Terminals 1 - 2: bus connection of programmable room unit (supplied as accessory)

Terminals 4 - 5: outdoor temperature sensor connection (supplied as accessory)

Terminal 3 : not used.

Terminals 6 - 7 - 8: see section 8.6.

Terminals 9 - 10: Indirect storage tank sensor connection for Utica Boiler MAH-125 & 165 model.

8 - ELECTRICAL CONNECTIONS

8.6 Install Room Thermostat

Install room thermostat on inside wall. Do not install where it will be influenced by drafts, hot or cold water pipes, lighting fixtures, television, sun rays or near a fireplace.

Dry contact only - do not apply 24 volts between 6 and 7.

A. Connect Room Thermostat

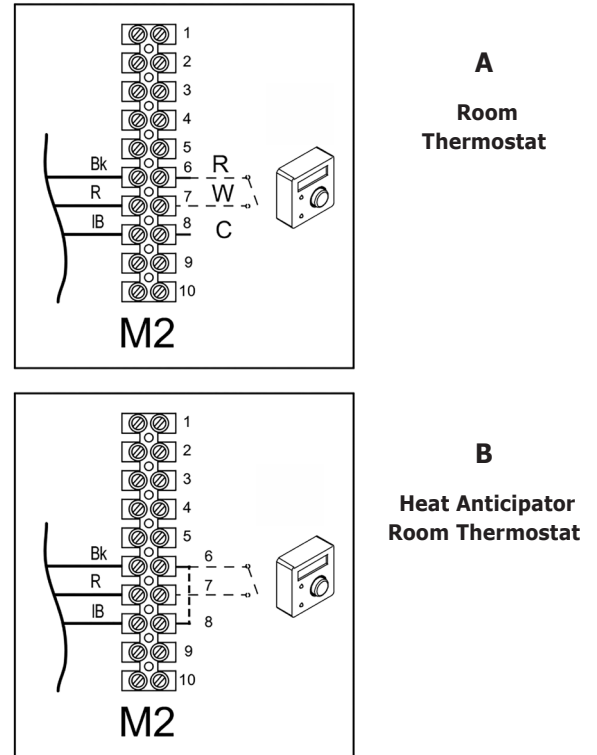
- turn power off to boiler;
- access terminal block **M2**;
- connect room thermostat to terminals **6(R)**-**7(W)**-**8(C)**; Do not apply dry volt between 2 terminals. Dry contact only.
- turn boiler power on;
- verify room thermostat operates per thermostat manufacturer instructions.

NOTE: maximum load allowed is 10 mA

B. Connect Heat Anticipator Room Thermostat

- turn power off to boiler;
- access terminal block **M2**;
- connect wires of Heat anticipator room thermostat to terminals **6-7**;
- connect bridge between terminals **6-8**;
- turn boiler power on;
- verify 24 V Heat anticipator room thermostat operates per thermostat manufacturer instructions.

FIGURE 8-4 Thermostat Connections



8 - ELECTRICAL CONNECTIONS

8.7 Optional Electrical Connections

A. 1K Ohm (1K Ω) Outdoor Temperature Sensor

To connect this accessory, see figure 8-5, terminals 4-5, and instructions supplied with **1K Ω** sensor.

B. Setting "Kt" Climate Curve

When external **1K Ω** sensor is connected to boiler, the electronic board adjusts the flow temperature calculated according to set Kt coefficient.



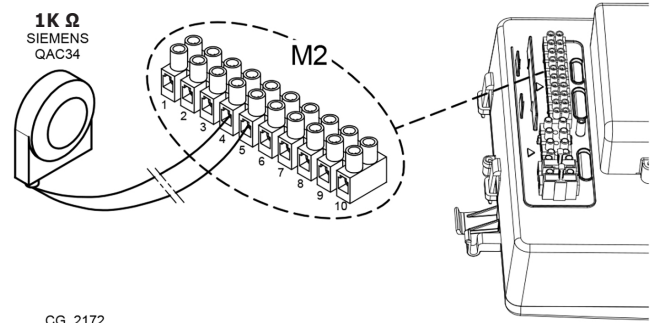
Select required curve by pressing   as indicated in chart below for selecting the appropriate curve (00 to 90).

FIGURE 8-5 Outdoor Sensor Connections



Note Sensors used for this boiler are proprietary to the manufacturer. Use of after market sensors will diminish boiler performance.

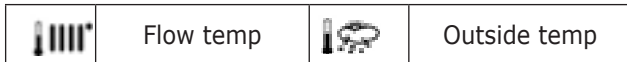
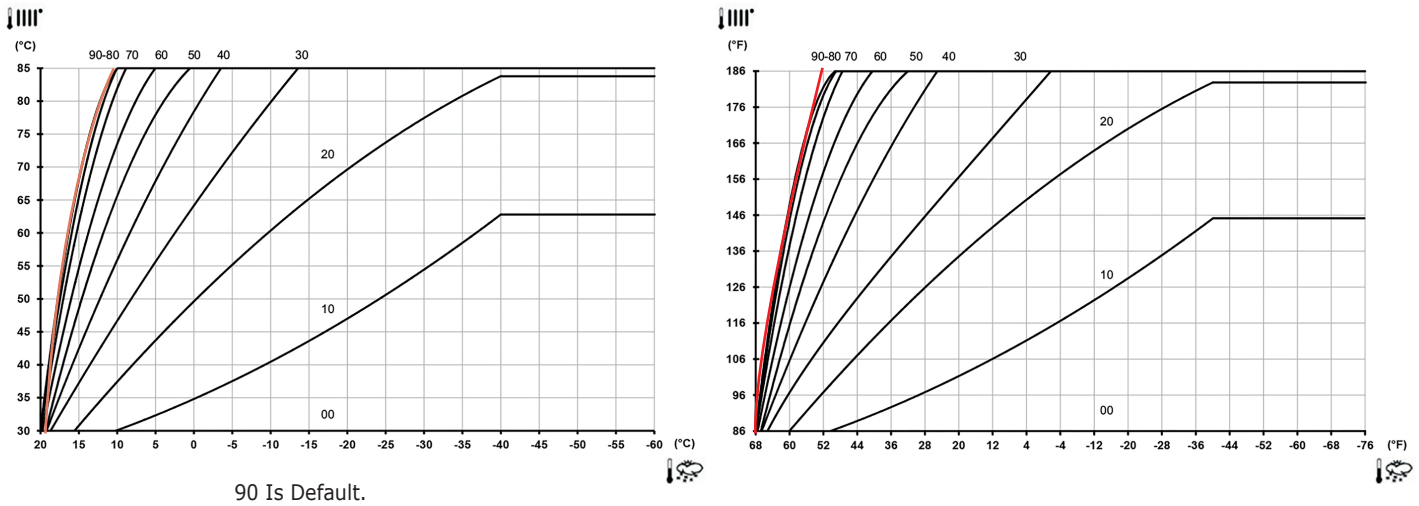




FIGURE 8-6 Kt Climate Curves



NOTE: Temperatures below -40 °F (-40 °C), maximum heating flow temperature set point no longer increases, curves shown on graph become horizontal.

8.8 Indirect Storage Tank

Boilers MAH-125 & MAH-165 can be electrically connected to indirect storage tank as follows:

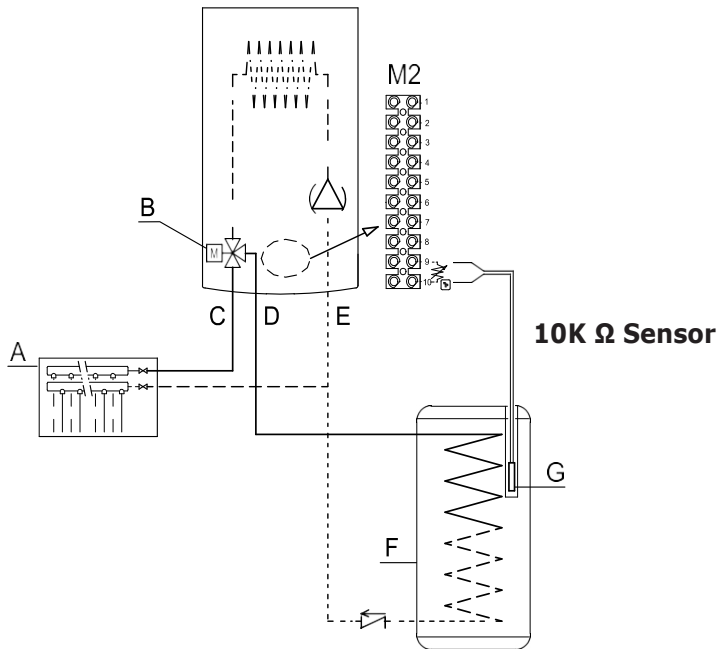
- Connect DHW priority **10K Ω** sensor NTC to terminals **9-10** on terminal block **M2**.
- Insert **10K Ω** NTC sensor element in the sensor well of indirect storage tank.
- Verify exchange capacity of the storage boiler coil is appropriate for boiler power.
- Adjust DHW temperature +95 °F...+140 °F (+35 °C...+60 °C) by pressing   on boiler Controll.

IMPORTANT: set parameter P03 = 05 as described in: "PARAMETER SETTINGS".

Note Sensors used for this boiler are proprietary to the manufacturer. Use of after market sensors will diminish boiler performance.

FIGURE 8-7A Kt Indirect Storage Tank

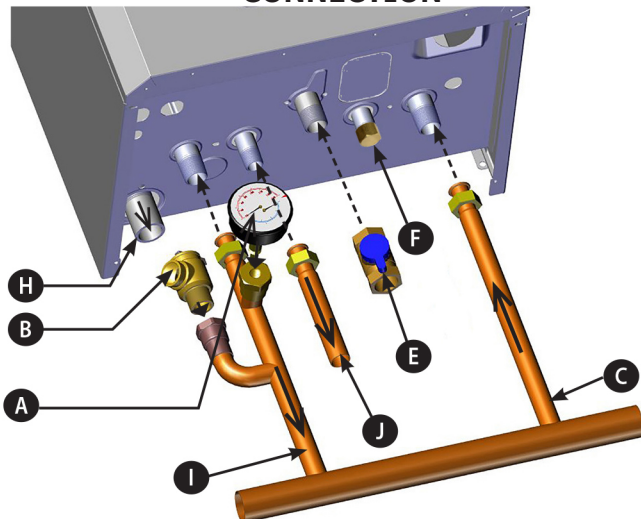
*125 Model shown - See Application Guide for size 165



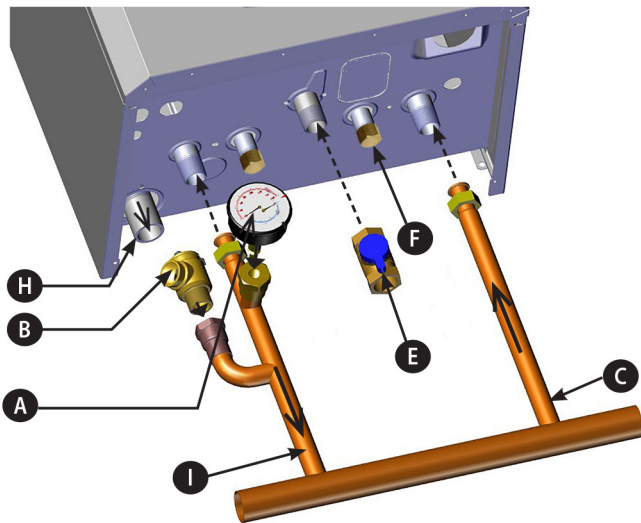
A	Heating system
B	Three way diverter valve
C	Heating water flow
D	Heating supply to DHW indirect storage tank coil
E	Heating water return
F	Tank
G	Optional 10k Ω DHW priority sensor tank

9.1 Central Heating System Connections - Heat Only

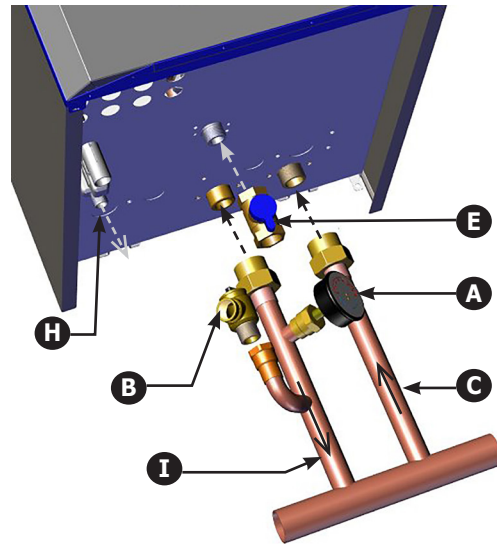
**MAH-125 HEATING ONLY
WITH OPTIONAL INDIRECT DHW
CONNECTION**



**MAH-125 HEATING ONLY
WITHOUT OPTIONAL INDIRECT
DHW CONNECTION**



MAH-165 HEATING ONLY

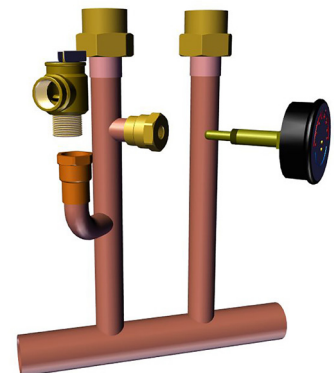


LEGEND		125	165
A	Pressure Gauge		-
B	Pressure Relief Valve	30.00 psi [2.11 bar]	
C	Heating return connection	3/4" [22.2mm]	1" [25.4mm]
E	Gas shutoff connection	3/4" [22.2mm]	
F	Boiler filling connection	1/2" [15.9mm]	na
H	Drain connection for condensate	13/16" [21mm] ID Hose	3/4 NPT
I	Heating supply connection	3/4" [22.2mm]	1" [25.4mm]
J	Optional Indirect DHW connection	1/2" [15.9mm]	na

**MANIFOLD
MAH-125**

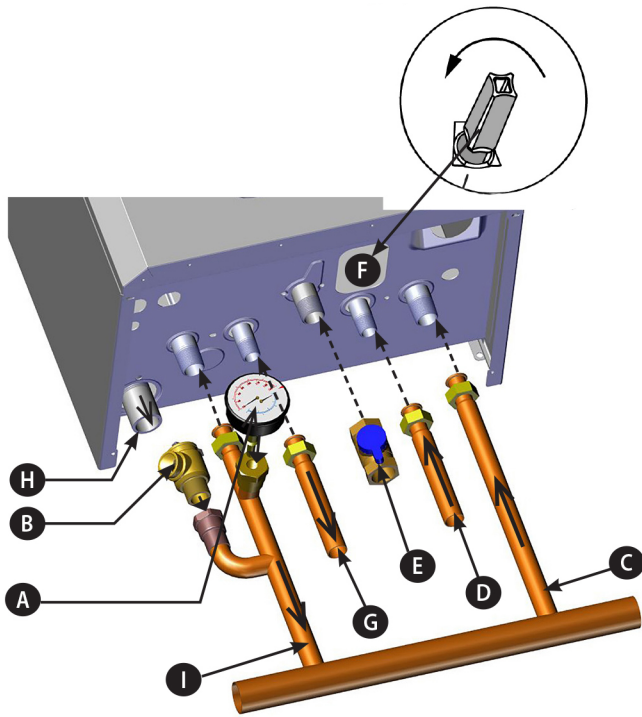


**MANIFOLD
MAH-165**

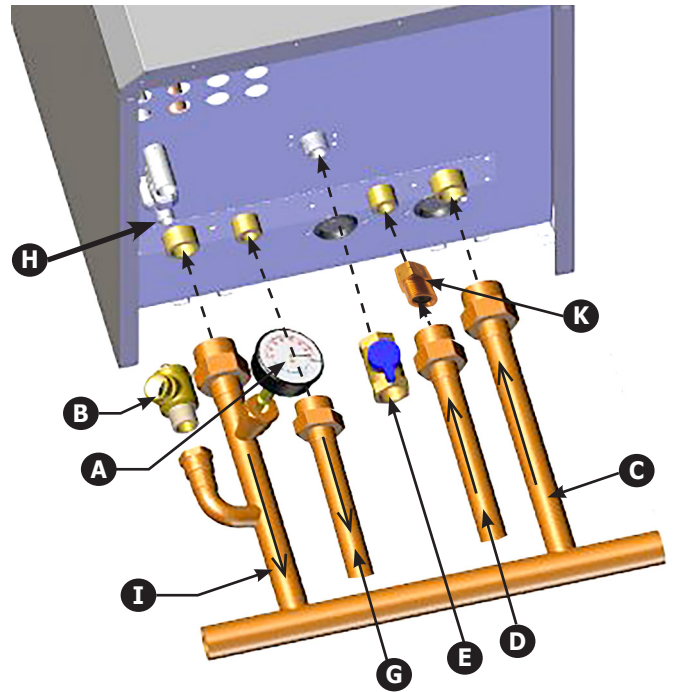


9.2 Central Heating System Connections - Combi

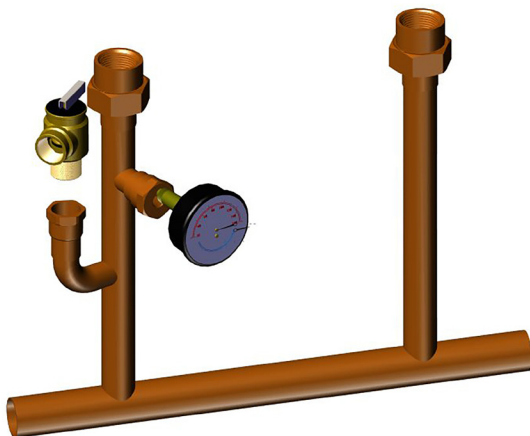
MAC-150 COMBI



MAC-205 COMBI



**MANIFOLD
MAC-150/205**



LEGEND		150	205
A	Pressure Gauge	-	
B	Pressure Relief Valve	30.00 psi [2.11 bar]	
C	Heating return connection	3/4" [22.2mm]	1" [25.4mm]
D	Cold DHW inlet tap / system filling connection for Combi	1/2" [15.9mm]	3/4" [22.2mm]
E	Gas shutoff connection	3/4" [22.2mm]	
F	Boiler filling connection	1/2" [15.9mm]	na
G	DHW outlet/indirect storage tank connection	1/2" [15.9mm]	3/4" [22.2mm]
H	Drain connection for condensate	13/16" [21mm] ID Hose	3/4 NPT
I	Heating supply connection	3/4" [22.2mm]	1" [25.4mm]
K	5 gpm DHW flow restrictor (Factory installed) (205 only)	na	3/4" [22.2mm]

9.3 System Start Up

Follow all codes and regulations when filling the boiler.

Use drain taps to allow system to completely drain.

Thoroughly flush the heating system before boiler is connected and again after first heating.

- Boiler is fitted with automatic air vent positioned on pump Vent and is fitted with adjustable sealing cap. See Figure 9-1.
- Open central heating flow and return valves. Spindle is flat in-line with valve.
- Open fill point valve on filling system until water begins to flow. To aid venting boiler drain may be open until water flows out. Close drain as soon as water appears.
- Systems using radiators to remove air - Vent each radiator in turn, starting with lowest in the system.
- It is important the pump is properly vented to avoid running it dry and damaging its bearings. Unscrew and remove cap from center of pump. Use screwdriver. Rotate exposed spindle about half turn, replace cap.
- Check operation of heating pressure relief valve. Pull lever on top of valve upwards lifting the seat. This will allow water to escape from system. Check water is escaping from the system.
- Open cold water supply inlet valve. Turn on all hot water taps. Allow water to flow until no air is present. Turn off taps. See page 4- Physical Data and section 2.7 Operational Features.

9.4 Fill Condensate Trap with Water

⚠ WARNING

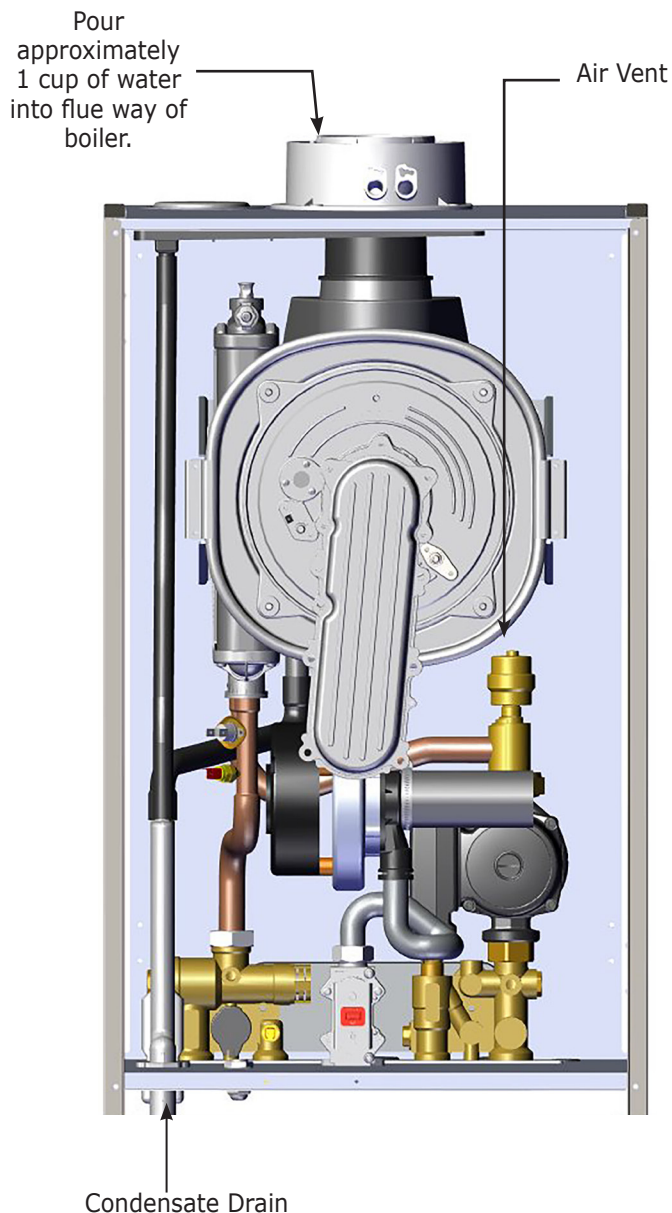
Asphyxiation hazard! Fill condensate trap before starting boiler to avoid combustion products escaping boiler. Failure to follow these instructions could result in death or serious injury.

- To fill the condensate trap pour water into exhaust vent until water begins to flow through the siphon.
- Visually inspect the siphon to ensure it is full with clean water.
- During operation check condensate trap to ensure it draining properly.

Note Condensate trap must be manually filled with water at initial start up.

FIGURE 9-1 Condensate Drain Assembly

Model 205 shown (location similar in all sizes)



9 - START UP PROCEDURE






9.5 Control Panel

Press and hold **(i/P)** for 1 second, to display information as shown in the table below.

Press **(O/R)** to exit.













i	DESCRIPTION	i	DESCRIPTION
00	Secondary fault internal code	09	Setpoint Central Heating (°F/°C)
01	Heating flow temperature (°F/°C)	10/11	Manufacturing information
02	Outdoor temperature (°F/°C)	12	Flue sensor temperature (°F/°C)
03	Indirect Tank DHW temperature (boiler CH only)	13	Manufacturing information
04	Domestic hot water temperature (boiler with plate exchanger)	14	Identification Open Therm communication
05	Water pressure in heating system (PSI/bar)	15	Manufacturing information
06	Heating return temperature (°F/°C)	16	Manufacturing information
07	Thermo fuse status (000/001)	17	Fan speed ("i17"x100)
08	Not used	18	Manufacturing information

BUTTONS Key

	DHW temperature adjustment (+ to increase the temperature and - to decrease it)
	Heating water temperature adjustment (+ to increase the temperature and - to decrease it)
	Boiler operating information
	Operating mode: DHW – DHW & Heating – Heating Only
	Off – Reset – Exit menu/functions



SYMBOL Key







	Off: heating and DHW disabled (only boiler frost protection is active)		Burner lit
	Ignition fault		DHW operating mode enabled
	Boiler/system water pressure low		Heating mode enabled
	Call a qualified service technician		Programming menu
	Manually resettable fault ()		Boiler information menu
	Fault in progress	°C, °F, bar, PSI	Set unit of measurement (SI/US)

NOTICE

All connections shall be made and water added before performing this function.

9.6 Commissioning

When lighting the boiler for the first time perform the following procedure:







1. Turn power to boiler on. Code **"000"** appears on the display. Appliance is ready for "commissioning" procedure.
2. Press  at the same time. Hold for 6 seconds. **"On"** appears on the display for 2 seconds followed by code **"312"** indicating **"de-aeration"** function is active. This function lasts 10 minutes.
3. Boiler will turn on after deaeration function is complete. Display will show code **"000"** alternating with **%** of ignition power and temperature value (°F / °C).
 - During this **gas recognition function** phase which lasts about 7 minutes, type of gas being used is analyzed.
 - During this function, assure maximum heat exchange to heating or DHW system (domestic hot water demand) by having all heating zones open or all domestic hot water taps open, in order to prevent boiler from switching off due to overheating.
 - If boiler operates on Gas A (Natural Gas), display shows **NG** (Natural Gas) for about 10 seconds. Boiler is now ready for normal operation.
 - If display shows **LPG** (Gas E), press  and  together and hold down for at least 4 seconds to exit without changing factory setting. Boiler will stay set to Natural Gas.
 - If boiler operates on Gas E (LPG) display shows **LPG** (Gas E). Press  for at least 6 seconds to confirm gas used.
 - If display shows **NG** (Gas A) and does not recognize the type of gas used, press  and  together and hold down for at least 4 seconds to exit the function. Then change parameter **P02=01** as described in section 9.12 Parameter Settings of boiler Installation, Operation and Maintenance Manual.

9.7 Calibration Function:

Boiler must be in stand by mode (no requests) before initiating the function.

The function consists of an automatic sequence and a manual sequence.


Automatic Sequence

- a. Press together for 6 seconds the  and  buttons and then within 3 seconds the  button. After 6 seconds it is possible hear a 'click' of the gas valve and see **'On'** on the display;
- b. The function is active if  and  blink together;
- c. After ignition (also more than one attempt) the boiler works at maximum power for at least 1 minute, then at the ignition power, and at the end at minimum power. When the display shows **P** and  icons it means the value of the curve has been stored. During the function the display shows the power level and flow temperature alternately.

Note

Boiler must not shutdown during calibration. Open all heating zones in heating or DHW mode to ensure boiler does not shutdown.






NOTICE

During initial ignition, burner may not ignite. This may cause boiler to shut down until any air in gas pipes is vented. Repeat ignition procedure until gas reaches the burner. To reset boiler operation, press  for at least 2 seconds.

NOTICE

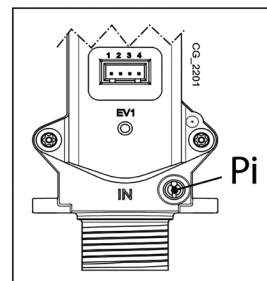
First ignitions immediately after installation, system will implement a self-learning procedure to reach correct ignition level.

IMPORTANT INFORMATION

- A. If venting or gas recognition function is interrupted by power blackout, start function again when power is restored. Press  and  together and hold at same time for at least 6 seconds.
- B. If display shows fault **E118** (low pressure in hydraulic circuit) during venting function, open filling tap on appliance and restore correct pressure.
- C. If gas recognition function is interrupted due to fault (e.g.: **E133** no gas) press  to reset. Then press  and  (for at least 6 seconds) to restart the function again.
If gas recognition function is interrupted due to overheating, restart function by pressing and holding down together for at least 6 seconds.

- D. Combustion of this appliance has been factory controlled, calibrated and set for operation with **Gas A** (Natural Gas).
- E. During Gas Type Control Function, combustion ratio will increase for a short period of time while gas type is being established.





FIGURE 9-3 - Gas Inlet Tap - Pi



PI = Gas Supply Inlet Pressure Tap

9.8 De-Aeration Function

Used to eliminate air inside the heating circuit when boiler is installed or after maintenance when water is drained from primary circuit.

1. Press buttons   together and hold for 6 seconds. **On** appears on display for a few seconds, followed by program row **312**.
2. The electronic board will activate pump on/off cycle for 10 minutes. Function will automatically stop at end of the cycle.
3. To manually exit this function, press   buttons together and hold for 6 seconds.

9.9 Commission Set Up (Gas) - Changing The Type Of Gas

During the **first** installation boiler carries out an automatic commissioning function.

The system is able to detect the gas type present in the network.

Correct gas type setting, is made by pressing two buttons at the same time, see section 9.6 Commissioning.

Change of gas type is made **after** the first installation:

- Change parameter P02. See section 9.6 Commissioning and section 9.11 Parameter Settings.
- Check minimum gas pressure is suitable for selected gas:
 - Gas A (NG) = 3.5" (8.7mbar)
 - Gas E (LPG) = 8.0" (19.9mbar)
- Place supplied label with indication of gas type close to the data plate of boiler replacing the original.
- Manufacturer recommends verification of CO₂ concentration on the flue.

9.10 Chimney Sweep Function (CO₂ Adjust)

For correct boiler operation, content of (CO₂- O₂) in the combustion flue must be within tolerances indicated in table below.

COMBUSTION TABLE

		Gas A (Natural Gas) MAH-125		Gas A (Natural Gas) MAC-150		Gas A (Natural Gas) MAH-165		Gas A (Natural Gas) MAC-205		Gas E (LPG)	
		CO ₂ %	O ₂ %	CO ₂ %	O ₂ %	CO ₂ %	O ₂ %	CO ₂ %	O ₂ %	CO ₂ %	O ₂ %
Maximum power (100%)	Nominal value	8.7	5.4	9.0	4.9	9.0	4.9	9.0	4.9	10.0	6.0
	Permitted value	8.2 – 9.3	6.3 – 4.3	8.5 – 9.5	5.7 – 4.0	8.7 – 9.3	5.4 – 4.3	8.7 – 9.3	5.4 – 4.3	9.5 – 10.5	6.8 – 5.2
Ignition power (*)	Nominal value	8.7	5.4	8.7	5.4	8.7	5.4	8.7	5.4	10.8	4.8
	Permitted value	8.2 – 9.3	6.3 – 4.3	8.2 – 9.3	6.3 – 4.3	8.2 – 9.3	6.3 – 4.3	8.2 – 9.3	6.3 – 4.3	10.3 – 11.3	5.5 – 4.1
Minimum power (0%)	Nominal value	8.8	5.2	8.8	5.2	9.0	4.9	9.0	4.9	10.0	6.0
	Permitted value	8.2 – 9.3	6.3 – 4.3	8.2 – 9.3	6.3 – 4.3	8.7 – 9.3	5.4 – 4.3	8.7 – 9.3	5.4 – 4.3	9.5 – 10.5	6.8 – 5.2

(*) Automatically calculated from the PCB

Chimney Sweep Function enables boiler to generate maximum heating power.

After activation, boiler power % can be adjusted from minimum (0%) to maximum (100%) in DHW mode.

- Press and hold and at the same time for 6 seconds. When the function is enabled, displays shows "On" for few seconds followed by program row "303" alternating with % of boiler power.
- Press to gradually adjust power (increments of 1%).
- To exit press both buttons together for at least 6 seconds.

If value of CO₂-O₂ is different, check the electrodes and their relative distances. See Figure 11-1.

If necessary, replace electrodes and position them correctly. If problem persists, use "COMBUSTION ADJUSTMENT FUNCTION (CO₂%)". See Section 11 General Maintenance, Figure 11-1 Electrodes.

NOTICE

- Press to display instantaneous flow temperature for 15 seconds.
- Use a regularly calibrated combustion analyzer for combustion analysis.
- During normal operation boiler performs combustion control cycles. In this phase CO values higher than 400 ppm can occur for brief periods of time.

9.11 Combustion Adjustment Function (CO₂%)

This function sets out to partially adjust the value of CO₂%. Use the following procedure:

- Press buttons and together for at least 6 seconds. When the function is enabled, displays shows "On" for a few seconds followed by program row "304" alternated with the % of boiler power;

- After burner is lit, boiler reverts to maximum DHW power (100). When display shows "100" it is possible to partially adjust value of CO₂ %;
- Press and . Display shows "00" alternating with function number "304" (🔥 flashes);
- Press to raise or lower the amount of CO₂ (from -3 to +3);
- Press to save new value. Power value "100" will show on display again. Boiler continues operating at maximum DHW power.

This procedure can be used to adjust CO₂ to ignition power and minimum power by pressing after performing step 5 above.

- After saving the new value (step 5 above), press to set boiler to ignition power. Wait for value of CO₂ to stabilize. Adjust as described in step 4 of procedure (power value is a number <> 100 and <> 0). Repeat step 5 to save.
- Press to adjust boiler to **minimum power**. Wait for value of CO₂ to stabilize. Go to step 4 to adjust (power value = 00);
- Exit function by pressing and together for at least 6 seconds, see step 1.

9.12 Check Firing Rate

- Measure input, if a gas meter is installed in the system.
 - Turn off gas to all other appliances.
 - Activate some heating zones to dissipate heat.
 - Set boiler on high fire using Chimney Sweep Function.
 - Use ½, 1 or 2 cu ft dial on gas meter. Measure time required for two or more complete revolutions. Measure time for one or more minutes.
 - Calculate input.

9 - START UP PROCEDURE

For Natural Gas :

$$\text{Input (MBH)} = \frac{3600 \times \text{cu ft}}{\text{seconds}}$$

Example: Natural Gas - Gas flow from
Meter = 2 cu ft

Measured time = 72 seconds

$$= \frac{3600 \times 2 \text{ cu ft}}{72 \text{ seconds}} = 100 \text{ MBH}$$

For Propane (LP):

$$\text{Input (MBH)} = \frac{9160 \times \text{cu ft}}{\text{seconds}}$$

Input Rate (MBH)

For Metric formulas- See Glossary

- Compare measured input to table below. If calculated input is not in range given in Table below, check firing rate again after setting the combustion following steps in section 9.10.

Table 9-2 Input Rate @ High Fire (MBH)

Approximate Rate @ 100% Fire (MBH)	
Size	
125	125
150	153
165	164
205	205

9.13 Parameter Settings

Program boiler electronic board parameters as follows:

- Press **(MIR-)** and **(MIR+)** together, hold them down for 6 seconds until program "P01" appears on the display alternated with the set value;
- Press **(MIR-)** or **(MIR+)** to scroll the list of parameters;
- Press **(i/P)**, value of selected parameter begins flashing, press **(MIR-)****(MIR+)** to change the value;
- Press **(i/P)** to confirm the value or press **(O/R)** to exit without saving.

Further information in regards to parameters listed in the following table are supplied together with required accessories if necessary.

9.14 Description Of Parameters: Factory Settings		FACTORY SETTINGS	
		125-165	150-205
P01	Manufacturer information	01	
P02	Gas used 00 = Gas A (Natural Gas) 01 = Gas E (LPG Gas)	00	
P03	Hydraulic system 00 = instantaneous appliance 03 = instantaneous appliance with pre-heat function 04 = heating only appliance with DHW thermostat 05 = appliance with external storage indirect tank 08 = heating only appliance 13 = instantaneous appliance with pre-heat function for solar application	08	00
P04	Programmable relay 1 setting (optional): 00 = no function is associated 01 = close contact with a room thermostat request (other than ECR thermostat) 02 = close contact with a ECR room thermostat request 03 = relay for indicating low water pressure 04 = relay for error code display 05 = relay for kitchen fan function 07 = relay for post circulation pump 09 = DHW relay on with DHW program setting 10 = DHW relay on with DHW request; if P64 = 1 relay on with CH and DHW request 13 = relay for Cooling function 14 = close contact with room thermostat request (120V~) with post circulation 15 = close contact with open therm remote control request with post circulation	02	
P05	Programmable relay 2 setting (optional): (Same configurations as Relay 1- P04)	04	

parameters continued on
next page

9 - START UP PROCEDURE

9.14 Description Of Parameters: Factory Settings conti.		FACTORY SETTINGS	
		125-165	150-205
P06	Outdoor temperature sensor input configuration 00 = with outdoor temperature sensor connected, external temperature value has influence to calculate heating flow temperature setpoint 01 = with outdoor temperature sensor connected, display shows external temperature value (no influence) 02...05 = no function is associated	00	
P07	00..02 = No function is associated 03 = This is an input contact for CH request (e.g. trigger phone). When contact CN2 is closed and Room Thermostat (RT) requiring heat switches burner on. Note: <u>verify heating mode is enabled (winter or heat only mode)</u> 04 = This is an input contact for Low Temperature Thermostat (e.g. floor heating system). When Low Temperature Thermostat connected on CN2 cuts out, burner switches off and display shows E178 anomaly. Note: <u>verify heating mode is enabled (winter or heat only mode)</u> 05 = This is an input contact for external DHW recirculation pump. When contact CN2 is closed the pump runs for a specific period. To enable input it is necessary to set parameter P04 or P05 = 08 and P69 = 05 . Pump will run at P19 minutes (Summer/Winter mode or Only Winter mode) or P19/2 minutes (only Summer mode).	00	
P09	Manufacturer information	--	
P10	Heating setpoint setting OT / RT (Open Therm / Room Thermostat 120V~) 00 = with Remote Control (RC) connected, temperature request is RC setpoint 01 = Temperature Request is highest set point between RC and PCB 02 = Temperature request is RU setpoint. The RT enable the gas boiler operates	00	
P11..P12	Manufacturer information	--	
P13	Max. heating output (0-100%)	100	80
P14	DHW max. output (0-100%)	100	
P15	Min. heating output (0-100%)	00	
P16	Maximum CH setpoint (°C) 00 = 176°F (80°C) 01 = 113°F (45°C)	00	
P17	Pump overrun time in heating mode (01-240 minutes)	03	
P18	Burner ignition delay in CH mode (00-10 minutes) - 00=10 seconds	03	
P19	Manufacturer information	07	
P20	Pump overrun time in DHW mode (seconds)	30	
P21	Anti-legionellosis function 00 = Disabled - 01 = Enabled	00	
P22	Manufacturer information (set "22" to display parameters P71 and P72)	00	
P23	Maximum DHW setpoint temperature 113°-140°F (45°-60°C), Default 49 = 120°F	49	
P24	Manufacturer information	35	
P25	No water safety device	00	
P26..P31	Manufacturer information	--	
P32..P41	Diagnostics (See SERVICE Instructions)	--	
P44	Temperature unit setting 00 = °C 01 = °F	01	
P71 * P	Maximum fan speed	--	
P72 *	Minimum fan speed	--	

NOTE : To scroll to parameter **P71** and **P72** it is necessary to set **P22** to 22 before scrolling up to the parameter.

* See Tables : SECTION 12.2 - Parameters Setting For High Altitude.

9.15 Adjusting Maximum Heating Power

Maximum boiler heating power can be reduced to suit requirements of heating system it serves.

Table showing parameter **P13** values according to desired maximum power model is shown for each single boiler.

To access and edit **P13** values, proceed as described in Parameter Settings.

Boiler Model - PARAMETER P13 (%) / Heating Output

Btu/h	KW	MAH-125	MAC-150
20,400	6.0	0	0
23,800	7.0	4	3
27,200	8.0	7	6
30,700	9.0	11	9
34,100	10.0	15	12
40,900	12.0	22	18
47,700	14.0	30	24
54,500	16.0	37	29
61,400	18.0	44	35
68,200	20.0	52	41
75,100	22.0	59	47
81,900	24.0	67	53
88,700	26.0	74	59
95,500	28.0	80	65
102,300	30.0	88	71
109,200	32.0	96	75
112,600	33.0	100	80

Btu/h	kW	MAH-165	MAC-205
27,400	8.0	0	0
31,300	9.2	4	3
35,800	10.5	7	6
41,300	12.1	11	9
46,500	13.6	15	12
55,900	16.4	22	18
65,700	19.3	30	24
74,500	21.8	37	29
83,200	24.4	44	35
92,300	27.0	52	41
101,900	29.9	59	47
110,000	32.2	67	53
118,000	34.8	74	59
127,000	37.2	80	65
136,900	40.1	88	71
145,300	42.6	96	75
151,700	44.4	100	80

FOR YOUR SAFETY READ BEFORE OPERATING

⚠ WARNING

If you do not follow these instructions exactly, a fire or explosion may result causing property damage, personal injury or loss of life.

- This appliance is equipped with an ignition device which automatically lights burner. **Do NOT try to light this burner by hand.**
- Before operating smell all around appliance area for gas. Be sure to smell next to floor because some gas is heavier than air and will settle to the floor.
- **Use only your hand to turn the gas shutoff valve.** Never use tools. If valve will not turn by hand, do not try to repair it, call a qualified service technician. Force or attempted repair may result in fire or explosion.
- **Do not use this appliance if any part has been under water.** Immediately call a qualified service technician to inspect appliance and to replace any part of control system and any gas control which has been under water.

⚠ CAUTION

WHAT TO DO IF YOU SMELL GAS

- Do not try to light any appliance.
- Do not touch any electrical switch; do not use any phone in your building.
- Immediately call your gas supplier from a neighbor's phone. Follow the gas supplier's instructions.
- If you cannot reach your gas supplier, call the fire department.

10.2 Testing For Gas Leaks And Purging The Gas Supply

- With boiler gas service cock closed (spindle flats at right angles to valve). Pressure test gas supply and inlet pipe work connection to boiler gas service cock for soundness.
- Loosen screw of pressure inlet gas test port on gas valve. See section 13.4 Gas Valve. Verify gas supply is ON. Open boiler service cock to purge.
- Retighten test port screw and test for gas leaks. Close boiler gas shutoff device.

10.1 Boiler Sequence Of Operation

- With demand for heating, pump circulates water through the primary circuit.
- Combustion fan will come on and begin to run at ignition speed.
- Once fan reaches ignition speed control board will allow power to flow to spark generator and gas valve creating ignition in combustion chamber. Flame sensor will acknowledge presence of flame in combustion chamber and send signal to control board.
- Temperature sensor will send signal to control board allowing control board to increase / decrease fan speed. Combustion fan will in turn modulate gas rate accordingly.
- Once central heating loop temperature exceeds central heating loop setpoint the unit will shutdown and go through 3 minute time delay (burner pause time) before another call for heat.
- During this time the pump will run for additional three minutes to dissipate any residual heat.

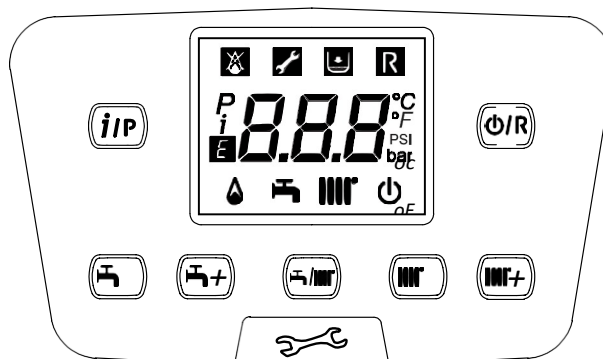
10.3 Boiler Controls

To light boiler correctly, proceed as follows:

- Check system pressure is correct;
- Power boiler;
- Open gas tap (positioned under boiler);
- Select required heating mode. See section 10.4 Operating Modes.

BUTTON Key

	DHW temperature adjustment (+ to increase the temperature and - to decrease it)
	Heating water temperature adjustment (+ to increase the temperature and - to decrease it)
	Boiler operating information
	Operating mode: DHW - DHW & Heating - Heating Only
	Off - Reset - Exit menu/functions



SYMBOL Key

	Off: Heating and DHW disabled (only boiler frost protection is active)		Burner lit
	Ignition fault		DHW operating mode enabled
	Boiler/system water pressure low		Heating mode enabled
	Call a qualified service technician		Programming menu
	Manual reset fault		Boiler information menu
	Fault in progress	°C, °F, bar, PSI	Set unit of measurement

10 - OPERATING INSTRUCTIONS

10.4 Boiler Operation

Domestic hot water supply always takes priority over central heating.

Demand for hot water required during central heating period, boiler automatically switches to hot water mode until demand is satisfied i.e. storage water is to required temperature.

This interruption in central heating is only when demand for hot water is present and should not be noticed by the User.

10.5 Central Heating Mode

1. Call for heat. Pump will start to circulate central heating water, operating the flow switch.
2. Fan will run. Once fan speed is reached burner will light.
3. Burner output automatically adjusts to suit system demand; as temperature of water in boiler approaches that set by adjustable temperature selector, burner output is reduced.
4. When set temperature is reached, burner is turned off and fan stops. Pump continues to run for three minutes to remove residual heat build up in boiler. Burner will not relight for 3 minutes.
5. If CH sensor has not registered pre-set temperature but room thermostat is satisfied the burner is turned off. Fan stops. Pump continues to run for three minutes. In this instance there is no 3 minute delay before burner relights.
6. If there is demand for DHW during 3 minute burner delay, boiler will operate to provide DHW until tap is closed. Boiler will immediately revert to provide CH if there is demand.

10.6 Domestic Hot Water Mode

- Flow switch senses demand for hot water (opening a hot water tap, etc.), the pump starts and burner lights at its ignition output, increasing to its maximum output.
- Water in the boiler is diverted from central heating system to domestic hot water heat exchanger, heating the incoming supply water.
- Burner output is varied to maintain temperature of hot water as set by the adjustable temperature selector.
- When flow switch senses hot water is no longer required burner is turned off. Boiler immediately returns to central heating mode.

10.7 Frost Protection

Boiler has a built in frost thermostat which automatically turns boiler and pump on.

If water in boiler falls below 41°F (5°C), providing the display is switched on, boiler will operate until water temperature in the system reaches approximately 86°F (30°C).

Frost protection is for the boiler only and not for complete Central Heating System.

10.8 Pump

If display is switched on and boiler has not operated for 24 hours for heating or hot water, pump will operate automatically for five minutes every 24 hours.

10.9 Low Water Pressure Sensor (Internal)

This device protects the primary exchanger from damage. It will not allow the boiler to run in a LOW water pressure situation. Low water condition occurs when water pressure drops below 7.0 psi (0.5 bar), approximately.

DANGER

Before servicing, turn off electrical power to boiler at service switch. Close manual gas valve to turn gas supply OFF to boiler. Failure to comply will result in death or serious injury.

CAUTION

Label all wires prior to disconnection when servicing controls. Wiring errors can cause improper and dangerous operation.

Note Verify proper operation after servicing.

Note Perform regular service and maintenance by qualified service agency at least once every 12 months to assure safe, trouble free operation and maximum efficiency.

Note A Heat Exchanger cleaning kit is available for annual service of the boiler. See repair parts manual for part number.

- Circulator pump and combustion air blower motor furnished with boiler are permanently lubricated from factory and require no further lubrication. Lubricate field sourced pumps and/or motors according to pump and/or motor manufacturer's instruction.
- Check following components are operating properly and are free of blockages or obstructions:
 - air vent;
 - check venturi air inlet for blockage and clean as required;
 - verify pressure test port cap and combustion test port are in place;
 - return temperature sensor clip (if equipped) must be securely seated on pipe; Check boiler for any sign of leaks.
- Check external low water cutoff operation (if installed).
 - Check operation by pressing test button on low water cutoff.
 - "Low Water" LED on the external LWCO should illuminate and boiler should shut down.
 - Every 5 years remove low water cutoff. Reinstall after cleaning.
 - Every 10 years replace low water cutoff.
- Visual inspection of flame through sight glass. Burner should be fully illuminated.
- Check heating system expansion tank.

11.1 Beginning of Each Heating Season

- Check boiler area is free from combustible materials, gasoline, and other flammable vapors and liquids.
- Visually inspect combustion air and vent piping for proper operation. Check for and remove any obstruction to flow of combustion air or vent gases. Immediately repair or replace pipe showing deterioration or leakage. Reassemble per instructions in section 6. Ensure proper reassembly and resealing of system.
- Visually inspect condensate drain line for proper operation. Checking for deteriorated or plugged condensate drain line. Verify condensate trap drains freely and clean as required.
- Test safety relief valve for proper operation. Refer to valve manufacturer's instructions packaged with relief valve.
- Examine heat exchanger, burner, condensate lines, and clean (if necessary) by following instructions in section 11.3-Component Replacement And Cleaning.

11 - GENERAL MAINTENANCE AND CLEANING

WARNING

Following service procedures must be performed by qualified service agent. Boiler owner shall not attempt these steps. Failure to do so could result in death or serious injury.

WARNING

Combustion chamber insulation in this product contains ceramic fiber material. Ceramic fibers can be converted to cristobalite in very high temperature applications. The International Agency for Research on Cancer (IARC) has concluded, Crystalline silica inhaled in the form of quartz or cristobalite from occupational sources is carcinogenic to humans (Group1). Avoid breathing dust and contact with skin and eyes. Use NIOSH certified dust respirator (N95). This type of respirator is based on the OSHA requirements for cristobalite at the time this document was written. Other types of respirators may be needed depending on the job site conditions. Current NIOSH recommendations can be found on the NIOSH website <http://www.cdc.gov/niosh/homepage.html>. NIOSH approved respirators, manufacturers, and phone numbers are also listed on this website. Wear long-sleeved, loose fitting clothing, gloves, and eye protection. Apply enough water to the combustion chamber lining to prevent dust. Wash potentially contaminated clothes separately from other clothing. Rinse clothes washer thoroughly. NIOSH stated First Aid. Eye: Irrigate immediately. Breathing: Fresh air.

WARNING

Before servicing, turn off electrical power to boiler at service switch. Close manual gas valve to turn gas supply OFF to boiler. Test for gas leaks on any gas carrying components after servicing. Service not complete until appliance operation verified per Installation, Operation & Maintenance Manual provided with boiler.

CAUTION

Label all wires prior to disconnection when servicing controls. Wiring errors can cause improper and dangerous operation. Failure to follow these instructions could result in minor or moderate injury.

NOTICE

Perform regular service and maintenance by qualified service agency at least once every 12 months to assure safe, trouble free operation and maximum efficiency.

11.2 Maintenance And Routine Servicing

Check and service boiler as necessary.

Frequency of servicing will depend upon installation conditions and usage, manufacturer recommends annually.

- Check flue terminal outside and ensure it is not blocked.
- Operate boiler. Check operation of boiler's controls.
- Ensure all system connections and fittings are sound. Correct any joints and fittings that maybe leaking.
- Follow safety valve manufacturer recommendations for service.

To ensure boiler operates at peak efficiency, following checks must be performed every year:

- check appearance and tightness of gas and combustion circuit gaskets
- check condition and position of ignition and flame sensing electrodes
- check condition of burner and its connection to aluminum front plate
- check for dirt in combustion chamber. Use vacuum cleaner for this cleaning operation
- check gas valve is calibrated correctly
- check there is no dirt in condensate trap
- check central heating system pressure
- check expansion tank pressure
- check vent system, clean if necessary

Record details and maintain service history.

11.3 Component Replacement And Cleaning

1. Remove any deposits from heat exchanger using suitable soft brush. *Do not* use brush with metallic bristles.
2. Check condition of the combustion chamber insulation panels. Any damaged panels must be replaced.
3. Check condition of burner injector on the manifold, carefully clean it with a soft brush if necessary. *Do not* use a brush with metallic bristles this might damage the injector.
4. Remove any fallen deposits from bottom of inner case.
5. Clean burner with soft brush and check flame ports are clear. Blockages may be removed with stiffer brush.
6. Check condition of electrodes.
7. Check spark gap, positioning and height of electrodes.
8. Check fan impeller is clean and free to rotate.

⚠ DANGER

Before servicing, turn off electrical power to boiler at service switch. Close manual gas valve to turn gas supply OFF to boiler. Failure to comply will result in death or serious injury.

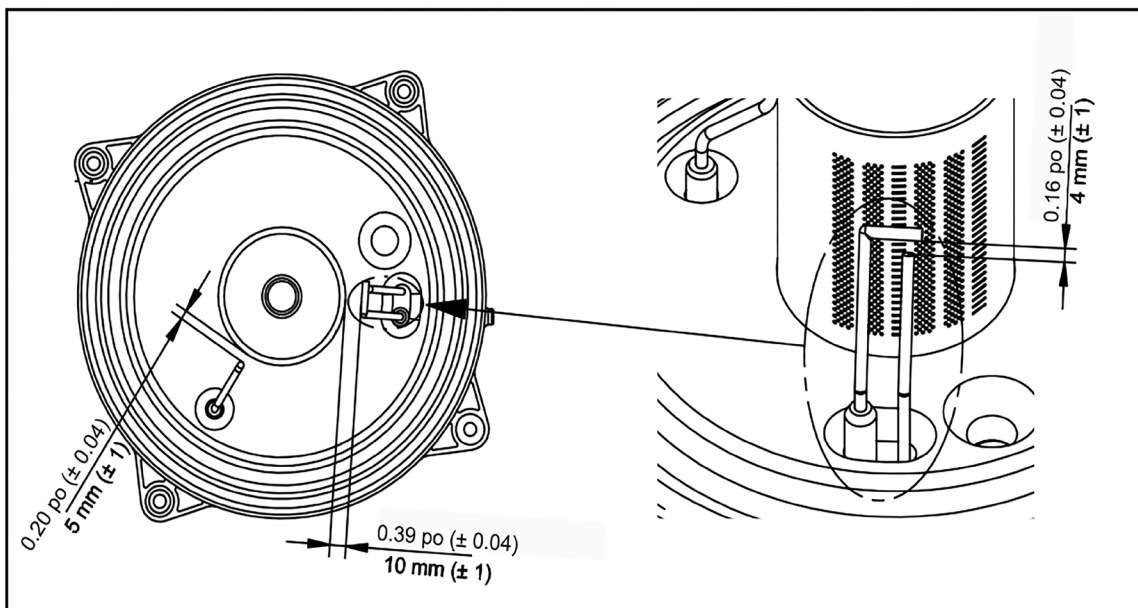
11.4 Draining the Boiler

- turn boiler off
- isolate electrical supply
- close boiler gas service cock
- allow boiler to cool
- drain boiler through onboard drain if available or external drain valve.

11.5 Draining the Heating Circuit

- Follow all steps in 11.4.
- Close central heating flow and return valves.
- Connect suitable pipe to drain point.
- Route it to suitable container.
- Open drain tap.

11-1 ELECTRODES



11 - GENERAL MAINTENANCE AND CLEANING

11.6 Hydraulic Unit (DHW)

For special areas, where water is harder than 200 ppm or 12 grains/ gallon, install polyphosphate dispenser or equivalent treatment system, compliant with current regulations.

11.7 Cleaning The Cold Water Filter

Boiler is fitted with cold water filter located on DHW hydraulic assembly (B). To clean:

- Drain domestic hot water system. (C - 150 only)
- 165 Drain is field supplied/installed.
- Remove nut on DHW priority sensor unit using 18mm wrench. (B)
- Pull out flow sensor and its filter.
- Remove any impurities.

NOTICE

When replacing and/or cleaning "O-rings" on hydraulic assembly (DHW), use only Molykote 111 as a lubricant, not oil or grease.

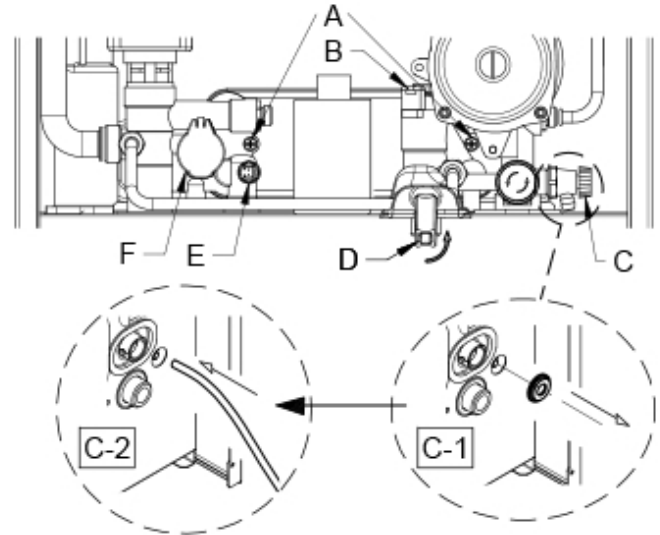
11.8 Final Commissioning

- Allow heating system to heat. Balance the system to achieve temperature difference across heating supply and return pipes at the boiler.
- Check system for proper volume and pressure. See page 4 for acceptable volume and pressure.
- Turn off boiler.
- Thoroughly flush water pipe work. Clean filters in heating return and supply water isolating valves.
- Repressurize the system.

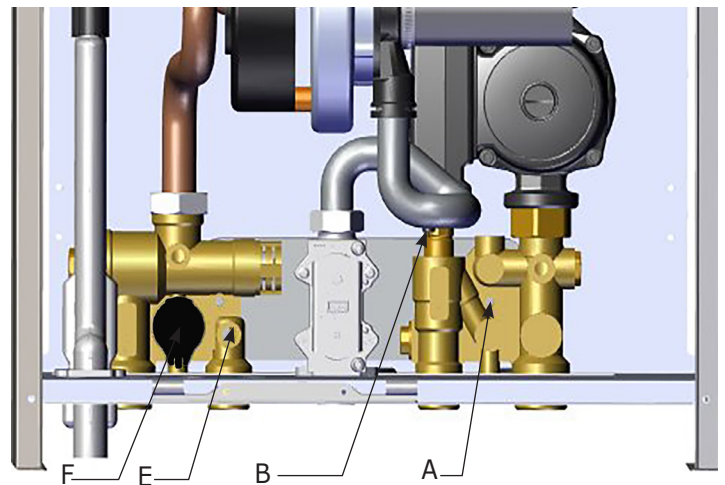
11.9 Final Assembly

- Place front jacket in position over boiler. Ensure bottom is located behind the control panel. Secure in position at top using screws previously removed.
- If boiler is to be left in service with the User, set controls and room thermostat.
- If boiler is not to be handed over immediately, close boiler gas service valve and turn off electrical supply.
- If there is possibility of boiler being left during frost conditions drain boiler and system. See section 11: Component Replacement Or Periodic Cleaning. Manufacturer recommends attaching a label to the boiler drawing attention to the fact that the system has been drained.

Model MAC-150



Model MAC-205



LEGEND

Hydraulic Assembly (B)

A	DHW exchanger fixing screw
B	DHW priority sensor with filter
C	Boiler/system drain tap (150 unit only) <i>(C-1 & C-2: access to tap C - bottom of boiler)</i>
D	Boiler / system filling tap (150 unit only)
E	DHW temperature NTC probe
F	Low water cutoff

11 - GENERAL MAINTENANCE AND CLEANING


11.10 User Information

Advise and demonstrated to User the following important information:

- A. How to light and turn off boiler. How to operate system controls.
- B. Importance of annual servicing of boiler to ensure safe and efficient operation.
- C. Servicing or replacement of parts shall be carried out by a qualified personnel.
- D. Ensure boiler controls and room thermostat, if fitted, are set to User's requirements.
- E. Tell User about sealed system pressure.
- F. Tell User if display is active and boiler has not operated for 24 hours for heating or hot water, the pump will automatically operate for 5 minutes.
- G. Explain to User an internal frost thermostat is fitted in boiler, and electrical supply to boiler must be left on for thermostat to operate.
- H. Show User position of pressure relief valve discharge pipe.
- I. Leave this Installation, Operation and Maintenance Manual with User for use on future calls.

11.11 Safety Flue Thermostat - DO NOT disable this safety device.

Safety Flue Thermostat found on the flue inside the boiler, interrupts flow of gas to the burner if the temperature overheats.

After verifying the cause of the trip, press  for about 2 seconds.

11.12 Flue Pressure Switch- DO NOT disable this safety device.

This device, positioned inside the sealed chamber, interrupts flow of gas to the burner if flue pressure exceeds 1.6 in w.c. (4 mbar). Verify if vent is blocked before resetting the boiler.

NOTICE

When servicing the appliance, check the condition and position of flame sensing electrode and replace it if necessary.

11.13 Replacement Parts

Perform Automatic Calibration procedure described as follows if one or more of the following components are replaced. Check and adjust CO₂% value as indicated in the Combustion Table.




Components replaced:

- Primary heat exchanger
- Fan
- Gas valve
- Gas nozzle
- Burner
- Flame sensing electrode

11.14 Automatic Calibration Function








Before performing this function verify there are no heat demands in progress.

During this function ensure there is maximum heat exchange to the system in Heating or DHW mode (DHW request) to avoid boiler shutting off due to overheating.

Press  and  together and hold for about 6 seconds. When display indicates "On" press  within 3 seconds after pressing previous buttons.

NOTICE

Important: If display indicates "303" Automatic Calibration function has not been activated. Disconnect boiler from main power supply for few seconds and repeat procedure.

1. When function is enabled,  and  will flash on the display.
2. After ignition sequence, which can also take place after few attempts, boiler performs three operations. Each operation lasts about 1 minute:
 - maximum power
 - ignition power
 - minimum power
3. Before moving to the following phase, from maximum power to ignition power and then to minimum power. *P* and  appear on the display.
4. During this phase, power level reached by boiler and delivery temperature alternate on the display.
5. When ,  and  flash together on the display, calibration function has terminated.
6. Press  to exit the function. Display will show **ESC**.

NOTICE

Important: If Calibration function does not complete the function, press  button to exit and decrease Maximum fan speed (parameter P71) before performing function again.

12 - RATINGS AND CAPACITIES

12 TECHNICAL DATA

12.1 Ratings and Capacity

AHRI CERTIFIED www.ahridirectory.org					
Model Number	CH Input, MBH ⁽¹⁾		⁽¹⁾⁽²⁾ CH Heating Capacity, MBH *	⁽¹⁾⁽³⁾ Net AHRI Rating Water, MBH	⁽²⁾ AFUE%
	Maximum	Minimum			
MAH-125	125	22	113	98	95.0
MAC-150	125	22	113	98	95.0
MAH-165	164	29.5	153	133	95.0
MAC-205	164	29.5	153	133	95.0

(1) 1000 Btu/hr (British Thermal Units Per Hour)
 (2) Heating Capacity and AFUE (Annual Fuel Utilization Efficiency) are based on DOE (Department of Energy) test procedures.
 (3) Net AHRI Ratings based on piping and pickup allowance of 1.15. Contact Technical Support before selecting boiler for installations having unusual piping and pickup requirements, such as intermittent system operation, extensive piping systems, etc.

*Max CH Supply temp 176° F (80°C)

12.2 Domestic Hot Water Specifications

Item	MAC-150	MAC-205
Input Ratings (MBH)	Min	22
	Max	153
Output Ratings (MBH)	Min	19
	Max	136
Domestic Water Pressure	2.9 psi (0.2 bar) - 116 psi (8.0 bar)	
Minimum Flow Rate	0.50 GPM	
Maximum Flow Rate	3.50 gpm	5.00 GPM
Flow Rate 77°F (43°C) Temp. Rise	3.25 GPM	4.65 GPM
DHW Supply Connection Size	1/2"NPT	3/4"NPT
Cold Water Input Connection Size	1/2"NPT	3/4"NPT

*Max DHW temp 140° F (60° C)

MAH-125	Natural gas (A) 17.4 mbar 7.0 in w.c.		LP gas (E) 27.4 mbar 11.0 in w.c.	
	0 - 2000 Ft 0 - 610 m	2000 - 4500 Ft 610 - 1370 m	0 - 2000 Ft 0 - 610 m	2000 - 4500 Ft 610 - 1370 m
Parameter P71 * Fan Speed (rpm)	115 5,650	60 5,100	65 5,150	40 4,900
Parameter P72 * Fan Speed (rpm)	40 1,150		25 1,000	
CO Limit (ppm)	<400			

MAC-150	Natural gas (A) 17.4 mbar 7.0 in w.c.		LP gas (E) 29.8 mbar 12.0 in w.c.	
	0 - 2000 Ft 0 - 610 m	2000 - 4500 Ft 610 - 1370 m	0 - 2000 Ft 0 - 610 m	2000 - 4500 Ft 610 - 1370 m
Parameter P71 * Fan Speed (rpm)	220 6,700	170 6,200	170 6,200	150 6,000
Parameter P72 * Fan Speed (rpm)	40 1,150		25 1,000	
CO Limit (ppm)	<400			

* To modify the fan speed see section 9.12.

12 - RATINGS AND CAPACITIES

12.3 High Altitude Parameter

For elevations between 2000 ft (600m) and 10,000 ft (3048m), use the following information:

Altitude	Model Number	Input, MBH (KW)		Heating Capacity, MBH*	AFUE, %	Domestic Hot Water (DHW) Circuit**			
		Maximum	Minimum			Max Input, MBH	Min Input, MBH	Max Output, MBH	Min Output, MBH
2,000-4,500 ft (600m-1350m)	MAH-125	113	22	101	95.0				
	MAC-150	113	22	101	95.0	137	22	122	19
	MAH-165	147	26.5	137	95.0				
	MAC-205	147	26.5	137	95.0	184.5	26.5	157	23
4,501-6,500 ft (1372m-1981m)	MAH-165	135	24.1	126	95.0				
	MAC-205	135	24.1	126	95.0	168	24.1	143	20
6,501-10,000 ft (1982m-3048m)	MAH-165	113	20.3	105	95.0				
	MAC-205	113	20.3	105	95.0	141	20.3	120	17
* Max CH Supply temp 176° F (80° C) for MAH-125 and MAC-150						**MAC-150 Max DHW Flow rate 3.5 GPM (13.2 l/min)			
* Max DHW temp 140° F (60° C)						** MAC-205 Max DHW flow rate 5.0 GPM (18.9L/min)			

13 - TROUBLE SHOOTING

13.1 Error Messages And Resetting The Boiler

E	Error Description	Operation
09	Gas valve connection fault	Check cable PCB/gas valve and gas valve plug
10	Outdoor sensor fault	Check sensor and cable
15	Gas valve command fault	Verify all cables. Replace PCB. Call authorized SERVICE center
20	Central Heating NTC sensor fault	Check sensor and cable
28	Flue NTC heat exchanger sensor fault	Check sensor and cable
40	Return NTC sensor fault	Check sensor and cable
50	Domestic Hot Water NTC sensor fault	Check sensor and cable
53	Obstruction in flue pipe, Recirculation, Out of Calibration, Poor gas quality	Check for obstruction in flue pipe. Check for recirculation, recalibrate, check gas quality
55	PCB not programmed	Call authorized SERVICE center
83-84-85 86-87	Communication problem between boiler board and control unit	Probable short circuit on wiring. Check cable between control unit and boiler
109	Pre-circulation alarm (temporary fault)	Check correct circulation of water and pump. Check supply and return wiring is correct.
110	R	Safety thermostat tripped due to over temperature (pump probably blocked or air in heating circuit)
		Check safety thermostat and cable; check correct circulation of water and pump
118	Hydraulic pressure too low.	
		Refill heating system by opening cold water tap
117	Hydraulic pressure too high.	
		Relieve pressure via relief valve or drain. Ensure water feed is operating correctly.
125	R	No circulation of water (control performed via temperature sensor).
		Check correct circulation of water and pump. Check correct connection of NTC sensor on pipe
128	R	Loss of flame
		Check sensing electrode and cable, flue recirculation, electrical continuity between burner and ground. Enable automatic calibration. Call authorized SERVICE center.
130	R	NTC flue sensor tripped due to over temperature
		Check thermostat, correct circulation of water and pump. Check status of primary exchanger.
131	Thermo fuse tripped due to over temperature or wire harness disconnected from thermo fuse, off the board, or wire harness may be cut.	
		Check thermo fuse, correct circulation of water and pump. Check status of primary exchanger. Replace heat exchanger. Call authorized SERVICE center. Verify wire harness installation and continuity.
133	R	Ignition failure
		Check correct operation of condensate trap. Check sensing electrode, spark electrode and cable. Check flue recirculation, electrical continuity between burner and ground. Enable automatic calibration function. Call authorized SERVICE center
134	R	Gas supply valve blocked
		Check gas pressure, sensing electrode, spark electrode and cable, replace PCB if it necessary. Call authorized SERVICE center
135	Internal error	
		Verify all cables. Replace PCB. Call authorized SERVICE center
160	Fan fault	
		Check fan and cable
162/317	Incorrect power supply frequency.	
		Incorrect power supply frequency.
169	Flue pressure switch (contact open)	
		Check pressure switch and cable. Check obstruction on flue pipe
164/384	R	Fault flame (parasitic flame).
		Check correct operation of T. gas valve.
165/385	Input voltage too low.	
		Check power supply

To RESET **R** boiler press  button for at least 2 seconds.

For other error codes not described in table please contact manufacturer at 1(800) 325-5479.

14 - GLOSSARY

- **APPLIANCE** - Device to convert gas into energy; term includes any component, control, wiring, piping or tubing required to be part of the device.
- **ANSI** - American National Standards Institute, Inc. oversees the creation and maintenance of voluntary consensus standards, including ANSI Z21.13/CSA 4.9: Gas-Fired Low Pressure Steam and Hot Water Boilers.
- **ASME - Association of Mechanical Engineers**
Establishes rules of safety governing the design, fabrication, and inspection of boilers and pressure vessels, determining the MAWP of such vessels.
- **ASTM** - American Society for Testing and Materials. ASTM International is one of the largest voluntary standards development organizations in the world, a trusted source for technical standards for materials, products, systems, and services. Known for their high technical quality and market relevancy, ASTM International standards have an important role in information infrastructure that guides design, manufacturing and trade in the global economy.
- **AUTHORITY HAVING JURISDICTION** - Individual or organization adopting and enforcing codes, rules, and by-laws governing various concerns of the community. Commonly referred to as "final authority" for any matters relating to LIFE SAFETY and BUILDING CONSTRUCTION within a community.
- **BOILER** - Appliance intended to supply hot liquid for space-heating, processing or power purposes.
- **BTU** - Abbreviation for British Thermal Unit. Quantity of heat required to raise the temperature of 1 pound of water 1°F.
- **BURNER** - Device for the conveyance of gas or mixture of gas and air, to the combustion zone.
- **CALIBRATE** - Make fine adjustments or divide into marked intervals for optimal measuring.
- **COAXIAL VENTING** - Sharing the same center.
- **COMBUSTION** - Rapid oxidation of fuel gases accompanied by the production of heat and light. Complete combustion of fuel is possible only in the presence of an adequate supply of oxygen.
- **COMBUSTIBLE MATERIAL** - Materials made of or surfaced with wood, compressed paper, plant fibers, or other materials capable of being ignited and burned. Such material shall be considered combustible even though flame-proofed, fire-retardant treated, or plastered.
- **COMBUSTION AIR** - Air that is drawn into an appliance to mix with fuel and support combustion.
- **CONDENSATE** - Liquid separated from flue gas due to a reduction in temperature.
- **DIRECT VENT BOILER** - Boiler constructed and installed so that all combustion air is derived directly from outdoors and all vent gases are discharged to outdoors.
- **DOMESTIC** - Relating to household usage as opposed to commercial usage.
- **DOMESTIC WATER** - Potable drinking water - tap water.
- **DRAFT** - Pressure difference causes gases or air to flow through a chimney, vent, flue or appliance.
- **FLA** - Full load amps.
- **FLUE** - Enclosed passageway for conveying combustion gases.
- **FLUE GASES** - Products of combustion plus excess air in appliance flues or heat exchanger.
- **GAS SUPPLIER** - Party that sells the commodity of Natural Gas (Gas A) or LPG (Gas E).
- **HIGH-VOLTAGE** - Circuit involving a potential of not more than 600 volts and having circuit characteristics in excess of those of a low-voltage circuit.
- **HYSTERESIS (DIFFERENTIAL)** - Difference between the temperature at which the thermostat switches off - and the temperature at which it switches on again.
- **IGNITER** - Device utilizing electrical energy to ignite gas at the main burner.
- **LEAK CHECK** - Operation performed on a gas piping system to verify the system does not leak.
- **LICENSED QUALIFIED INSTALLER / SERVICE TECHNICIAN** - Any individual, firm, corporation or company that either directly or through a representative is engaged in the installation, replacement, repair or servicing of gas piping, venting systems, appliances, components, accessories, or equipment, and whose representative is experienced and trained, in such work and has complied with the requirements of the authority having jurisdiction.
- **LOW WATER CUTOFF** - Device constructed to automatically cut off fuel supply when the surface of water in the boiler falls to the lowest safe water level.
- **LOW-VOLTAGE** - Circuit involving a potential of not more than 30 volts.

- **METRIC GAS METERS**

- Natural Gas**

$$\text{MBH} = \frac{127,116 \times \text{cu meters}}{\text{Seconds}}$$

For example: Gas Meter measures 0.1 cubic Meters in 100 seconds

$$\text{MBH} = \frac{127,116 \times 0.1}{100} = 127 \text{ MBH}$$

- Propane Gas (LP)**

$$\text{MBH} = \frac{383,482 \times \text{cu meters}}{\text{Seconds}}$$

- **NATIONAL BOARD OF BOILER AND PRESSURE VESSEL**

INSPECTORS - Group composed of boiler and pressure vessel inspectors representing states, cities and provinces enforcing pressure equipment laws and regulations.

- **PRESSURE TEST** - Operation performed to verify gas tight integrity of gas piping following its installation or modification.

- **PURGE** - To free gas conduit of air or gas, or mixture of gas and air.

- **PURGE TIME** - Period of time intended to allow for dissipation of any unburned gas or residual products of combustion.

- **QUALIFIED AGENCY** - Any individual, firm, corporation, or company engaged in and responsible for:

- Installation, testing, or replacement of gas piping, or connection, installation, testing, repair or servicing of appliances and equipment.
 - Experienced in such work.
 - Familiar with all precautions required.
 - Complies with all requirements of authority having jurisdiction.

- **SAFETY RELIEF VALVE** - Valve designed to relieve pressure in hot water supply system when pressure exceeds pressure capability of equipment.

- **SAFETY SHUTOFF DEVICE** - Device that will shut off gas supply to controlled burner in event source of ignition fails.

- **SEDIMENT TRAP** - Gas piping arrangement designed to collect any liquid or solid contaminant before reaching gas valve.

- **SERVICE** -Supply, installation, or maintenance of goods carried out by a Qualified Installer / Service Technician.

- **TWO PIPE SYSTEM** - Type of venting that allows for exhaust flue and intake air piping to be separated from each other. Fresh air may be drawn in at a different area from where flue terminal is located.

- **VENT** - Passageway used to convey flue gases from appliance vent connector to outdoors.

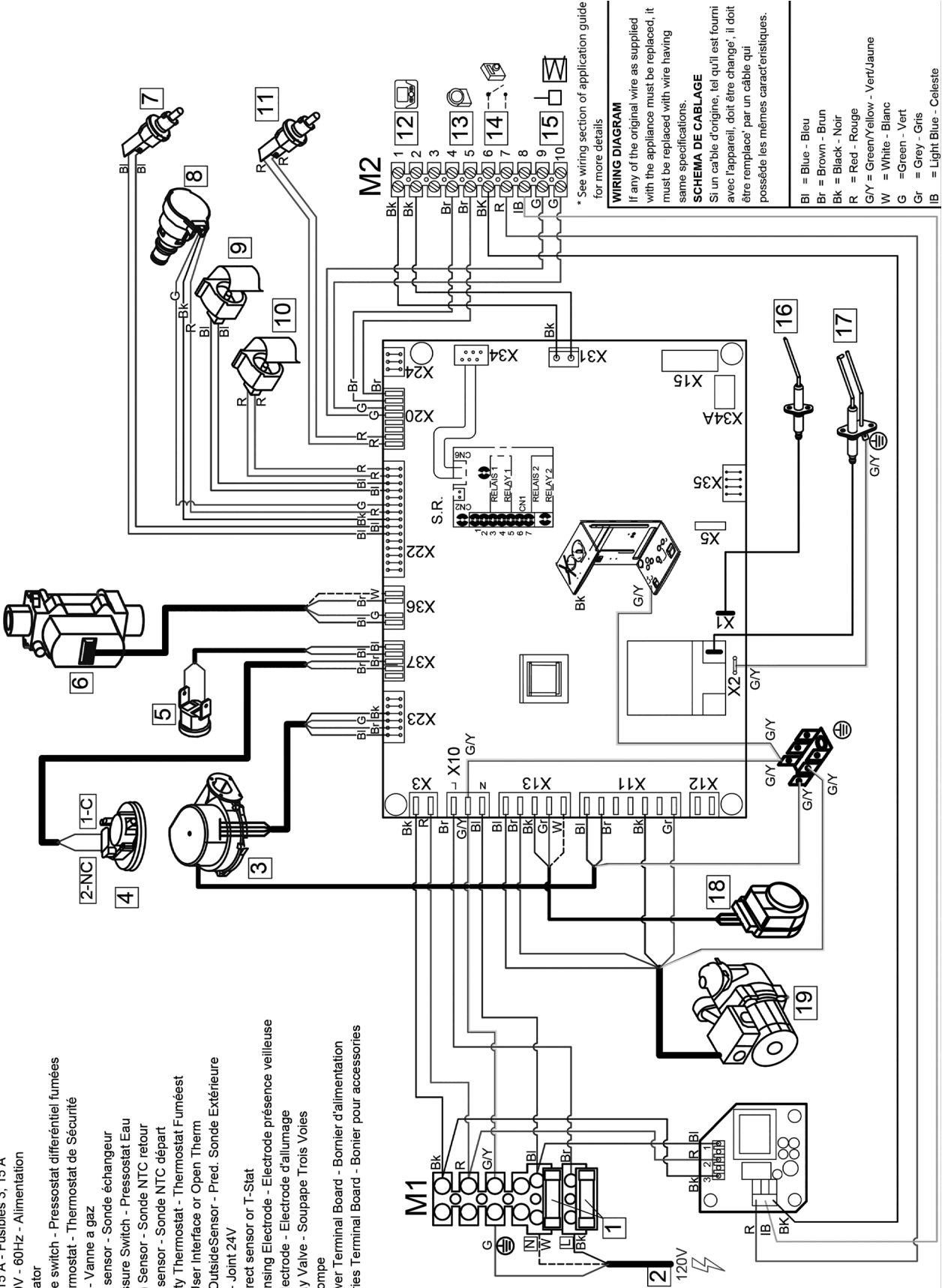
- **VENTING SYSTEM** - Continuous open passageway from of appliance vent connector to outdoors for purpose of removing flue or vent gases.

A-1 MODELS 125 - Heat Only

240011359 REV C 125

LEGEND - LEGENDE:

- 1-FUSES 3, 15 A - Fusibles 3, 15 A
- 2-Supply 120V - 60Hz - Alimentation
- 3-Fan - Ventilator
- 4-Air pressure switch - Pressostat différentiel fumées
- 5-Safety Thermostat - Thermostat de Sécurité
- 6-Gas Valve - Vanne a gaz
- 7-Exchanger sensor - Sonde échangeur
- 8-Water Pressure Switch - Pressostat Eau
- 9-NTC return Sensor - Sonde NTC retour
- 10-NTC flow sensor - Sonde NTC départ
- 11-Flue Safety Thermostat - Thermostat Fumées
- 12-Remote User Interface or Open Therm
- 13-Prev. for OutsideSensor - Pred. Sonde Extérieure
- 14-Link 24V - Joint 24V
- 15-DHW Indirect sensor or T-Stat
- 16-Flame Sensing Electrode - Electrode présence veilleuse
- 17-Ignition Electrode - Electrode d'allumage
- 18-Three Way Valve - Soupape Trois Voies
- 19-Pump - Pompe
- M1-Main Power Terminal Board - Bornier d'alimentation
- M2-Accessories Terminal Board - Bornier pour accessoires



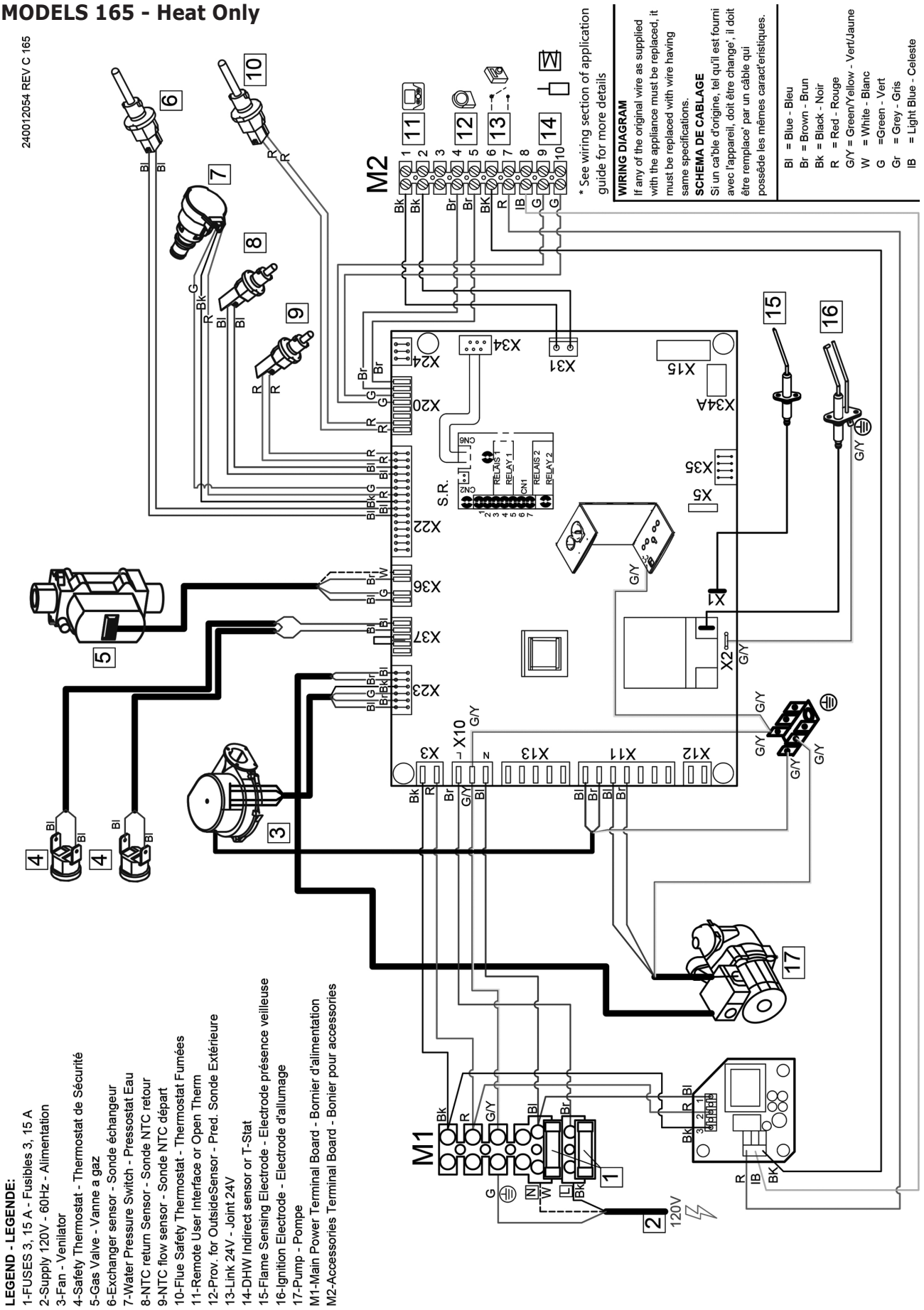
WIRING DIAGRAM
 If any of the original wire as supplied with the appliance must be replaced, it must be replaced with wire having same specifications.
SCHEMA DE CABLAGE
 Si un câble d'origine, tel qu'il est fourni avec l'appareil, doit être changé, il doit être remplacé par un câble qui possède les mêmes caractéristiques.

- Bl = Blue - Bleu
- Br = Brown - Brun
- Bk = Black - Noir
- R = Red - Rouge
- W = White - Blanc
- G = Green - Vert
- Gr = Grey - Gris
- IB = Light Blue - Celeste

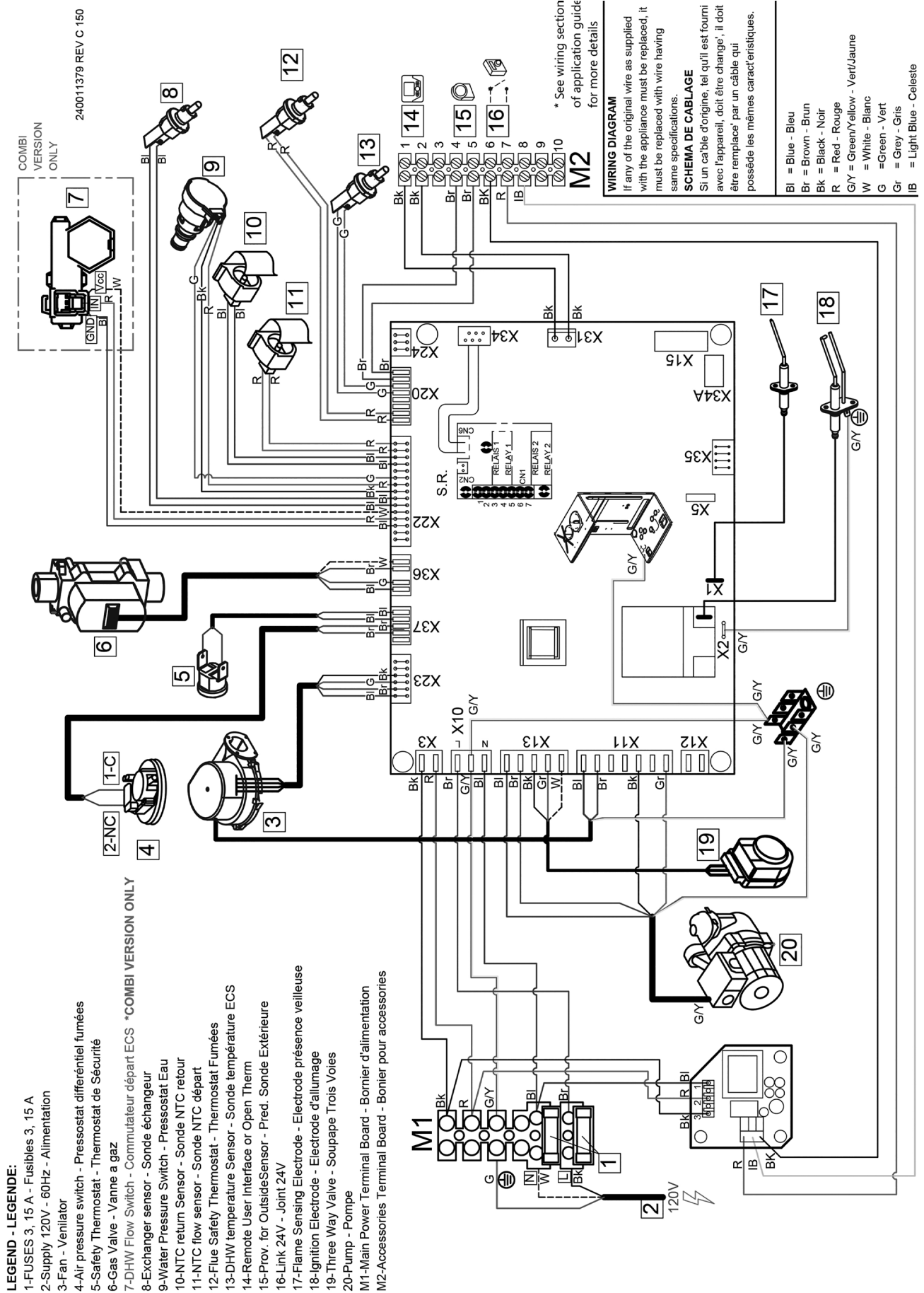
* See wiring section of application guide for more details

A-2 MODELS 165 - Heat Only

240012054 REV C 165



A-3 MODELS 150 - Combi

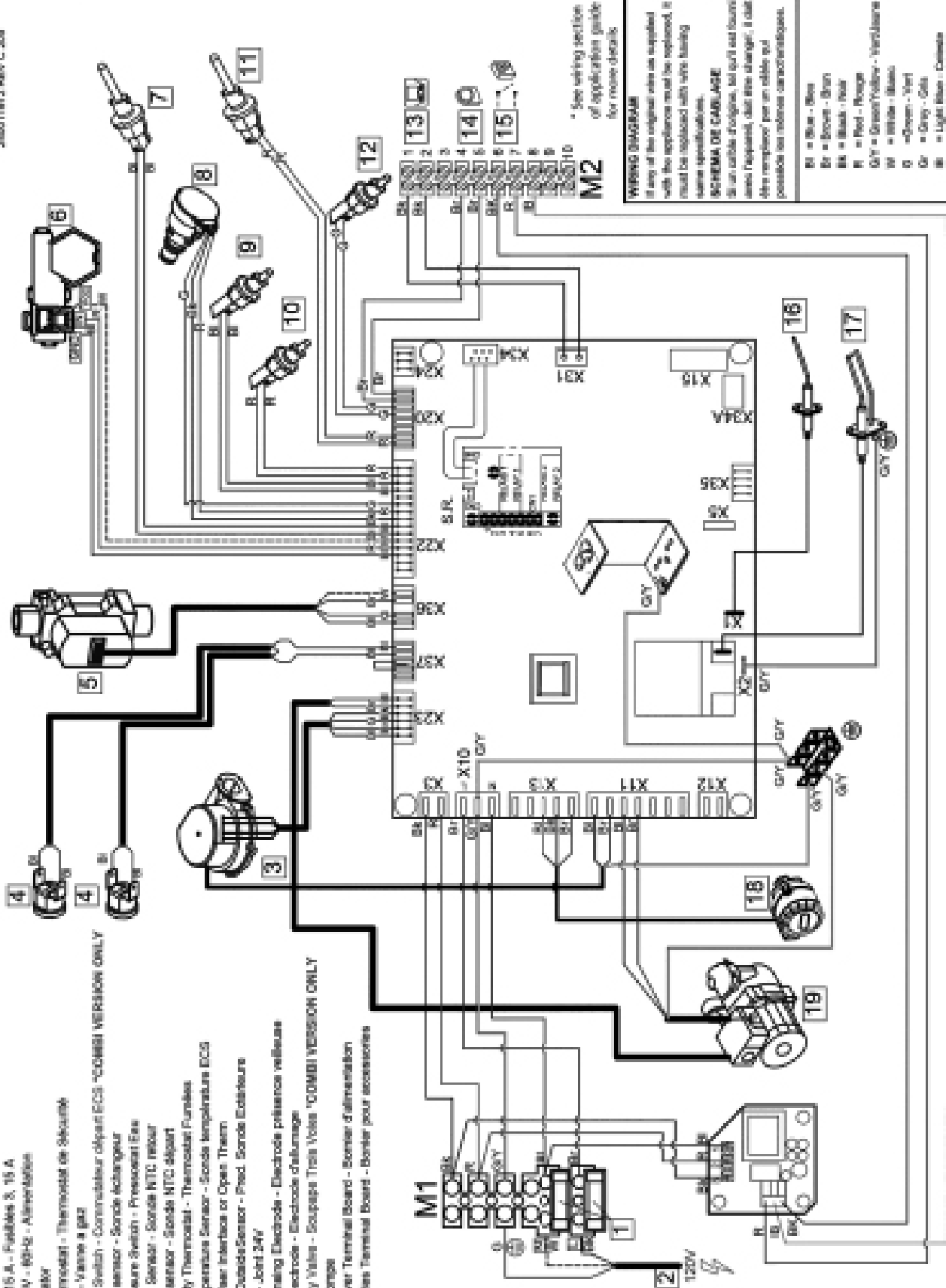


A-4 MODELS 205 - Combi

240011941 REV C 2018

LEGEND - LÉGENDE:

- 1-PLUSE 3, 15 A - Fusibles 3, 15 A
- 2-Supply 120V - 60Hz - Alimentation
- 3-Fan - Ventilator
- 4-Safety Thermostat - Thermostat de Sécurité
- 5-Gas Valve - Vanne à gaz
- 6-DHW Flow Switch - Commutateur d'arrêt ECS *COMBI VERSION ONLY
- 7-Exchanger sensor - Sonde échangeur
- 8-Water Pressure Switch - Pressostat Eau
- 9-NTC return Sensor - Sonde NTC retour
- 10-NTC flow sensor - Sonde NTC écoulement
- 11-Flue Safety Thermostat - Thermostat Fumées
- 12-DHW temperature Sensor - Sonde température ECS
- 13-Remote User Interface or Open Therm
- 14-Prov. for Outside Sensor - Pres. Sonde Extérieure
- 15-Unit 24V - Joint 24V
- 16-Flame Sensing Electrode - Electrode présence veilleuse
- 17-Griffen Electrode - Electrode d'allumage
- 18-Three Way Valve - Soupape Trois Voies *COMBI VERSION ONLY
- 19-Pump - Pompe
- M1-Main Power Terminal Board - Boîtier d'alimentation
- M2-Accessories Terminal board - Boîtier pour accessoires



* See wiring section of application guide for more details

WIRING DIAGRAM

If any of the original wires are replaced with the appliance must be replaced, it must be replaced with wire having same specifications.
 SCHEMA DE CÂBLAGE
 Si un câble d'origine, tel qu'il est fourni avec l'appareil, doit être changé, il doit être remplacé par un câble qui possède les mêmes caractéristiques.

- B1 = Blue - Bleu
- B2 = Brown - Brun
- Blk = Black - Noir
- R = Red - Rouge
- GY = Green/Yellow - Vert/Jaune
- W = White - Blanc
- G = Green - Vert
- Gr = Grey - Gris
- Lk = Light Blue - Ciel

INSTALLATION AND CHECK-OUT CERTIFICATE

Boiler Model _____ **Serial #** _____ **Date Installed** _____

Measured BTU/HR input _____

- Installation instructions have been followed**
- Checkout procedure and adjustments performed**
- Maintenance and Service issues reviewed with owner/ maintenance person**
- Installation booklet affixed on or adjacent to boiler**

Installer (Company) _____

Address _____

Phone _____

Installer's Name _____

Signature _____

IMPORTANT

In accordance with Section 325 (f) (3) of the Energy Policy and Conservation Act, this boiler is equipped with a feature that saves energy by reducing the boiler water temperature as the heating load decreases.

This feature is equipped with an override which is provided primarily to permit the use of an external energy management system that serves the same function.

THIS OVERRIDE MUST NOT BE USED UNLESS AT LEAST ONE OF THE FOLLOWING CONDITIONS IS TRUE:

- An external energy management system is installed that reduces the boiler water temperature as the heating load decreases.
- This boiler is not used for any space heating
- This boiler is part of a modular or multiple boiler system having a total input of 300,000 BTU/hr or greater.
- This boiler is equipped with a tankless coil.



ECR International Inc. 2201 Dwyer Avenue, Utica, NY 13501
Tel. 800 253 7900
www.ecrinternational.com

All specifications subject to change without notice.
©2018 ECR International, Inc.

**APPLICATION GUIDE
FOR USE WITH
HEATING ONLY - 125, 165
&
COMBI - 150, 205**

This manual has been prepared for use with the appropriate Installation, Operation and Maintenance Manual.



Manufactured by:
ECR International Inc.
2201 Dwyer Avenue, Utica, NY 13501
Tel. 800 253 7900
www.ecrinternational.com
PN 240011430 REV. H [07/31/2018]

TABLE OF CONTENTS

Important Safety Information	3
Labor Saving Piping Manifolds / Near Boiler Piping Connections	4
General Information - Hydronic Piping	6
General Information - Wiring	8
Piping and Wiring Diagrams	
Piping Legend.....	9
125 Zone Circulator Pumps - Piping Diagram	10
125 W/ Indirect Zone Pumps, DHW Tank, Tank Sensor - Wiring Diagram.....	11
125 W/ Indirect Zone Pumps & DHW Tank, Tank T-Stat - Wiring Diagram.....	12
125 With Zone Valves - Piping Diagram.....	13
125 With Zone Valves, DHW Tank, Tank Sensor - Wiring Diagram	14
125 Indirect Zone Valves, DHW Tank W/ Tank T-Stat - Wiring Diagram	15
165 With Zone Circulator Pumps - Piping Diagram	16
165 Indirect Zone Pumps, DHW Tank, Tank T-Stat - Wiring Diagram.....	17
165 With Zone Valves - Piping Diagram.....	18
165 Indirect Zone Valves, DHW Tank, Tank T-Stat - Wiring Diagram	19
150 & 205 With Zone Circulator Pumps - Piping Diagram.....	20
150 & 205 With Zone Pumps - Wiring Diagram.....	21
150 & 205 With Zone Valves - Piping Diagram	22
150 & 205 With Zone Valves - Wiring Diagram	23
Low Mass Piping and Wiring	
Low Mass - Piping Diagram	24
Low Mass - Wiring Diagram	25
Optional Equipment & Accessories	
Outdoor Temperature Sensor.....	26
Indirect Storage Tank Sensor & Thermostat.....	27
Wiring Diagrams	
125 - Heat Only Wiring Diagram	29
165 - Heat Only Wiring Diagram	30
150 - Combi Wiring Diagram	31
205 - Combi Wiring Diagram	32
Altitude Effects On Boiler Performance	33
Application Table - Indirect Tank Sizing	34
Low Water Cutoff Application	35

IMPORTANT SAFETY INFORMATION

1. General

Boiler installation shall be completed by qualified agency. See Installation, Operation & Maintenance Manual for additional information.

WARNING

Fire, explosion, asphyxiation and electrical shock hazard. Improper installation could result in death or serious injury. Read this manual and understand all requirements before beginning installation.

2. Become familiar with symbols identifying potential hazards.



This is the safety alert symbol. Symbol alerts you to potential personal injury hazards. Obey all safety messages following this symbol to avoid possible injury or death.

DANGER

Indicates a hazardous situation which, if not avoided, WILL result in death or serious injury.

WARNING

Indicates a hazardous situation which, if not avoided, could result in death or serious injury.

CAUTION

Indicates a hazardous situation which, if not avoided, could result in minor or moderate injury.

3. Installation shall conform to requirements of authority having jurisdiction or in absence of such requirements:

- *United States*
 - National Fuel Gas Code, ANSI Z223.1/NFPA 54.
 - National Electrical Code, NFPA 70.
- *Canada*
 - Natural Gas and Propane Installation Code, CAN/CSA B149.1.
 - Canadian Electrical Code, Part I, Safety Standard for Electrical Installations, CSA C22.1

4. Where required by authority having jurisdiction, installation shall conform to Standard for Controls and Safety Devices for Automatically Fired Boilers, ANSI/ASME CSD-1.

Additional manual reset low water cutoff or high limit may be required.

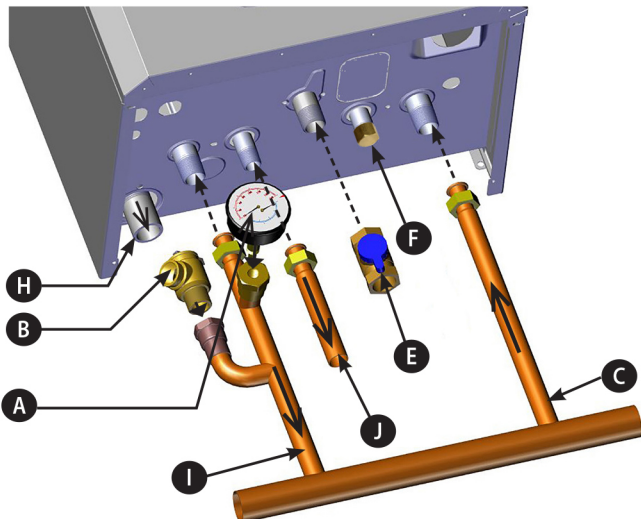
5. Requirements for Commonwealth of Massachusetts:

Boiler installation must conform to Commonwealth of Massachusetts code 248 CMR which includes but is not limited to:

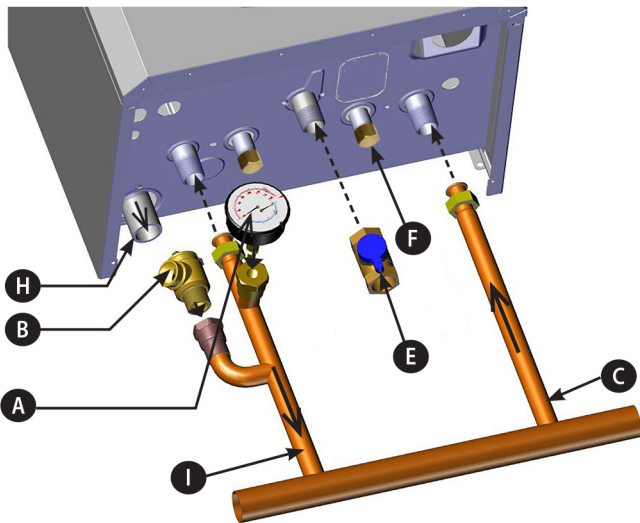
- Installation by licensed plumber or gas fitter.

LABOR SAVING PIPING MANIFOLDS / NEAR BOILER PIPING CONNECTIONS

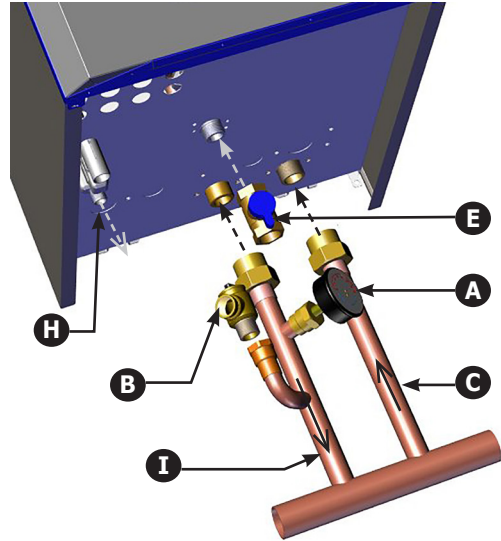
**125 HEATING ONLY
WITH OPTIONAL INDIRECT DHW
CONNECTION**



**125 HEATING ONLY
WITHOUT OPTIONAL INDIRECT
DHW CONNECTION**



165 HEATING ONLY

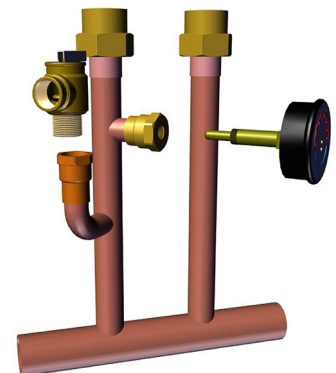


LEGEND		125	165
A	Pressure Gauge	-	
B	Pressure Relief Valve	30.00 psi [2.11 bar]	
C	Heating return connection	3/4" [22.2mm]	1" [25.4mm]
E	Gas shutoff connection	3/4" [22.2mm]	
F	Boiler filling connection (some models)	1/2" [15.9mm]	na
H	Drain connection for condensate	13/16" [21mm] ID Hose	3/4 NPT
I	Heating supply connection	3/4" [22.2mm]	1" [25.4mm]
J	Optional Indirect DHW connection	1/2" [15.9mm]	na

**MANIFOLD
125**

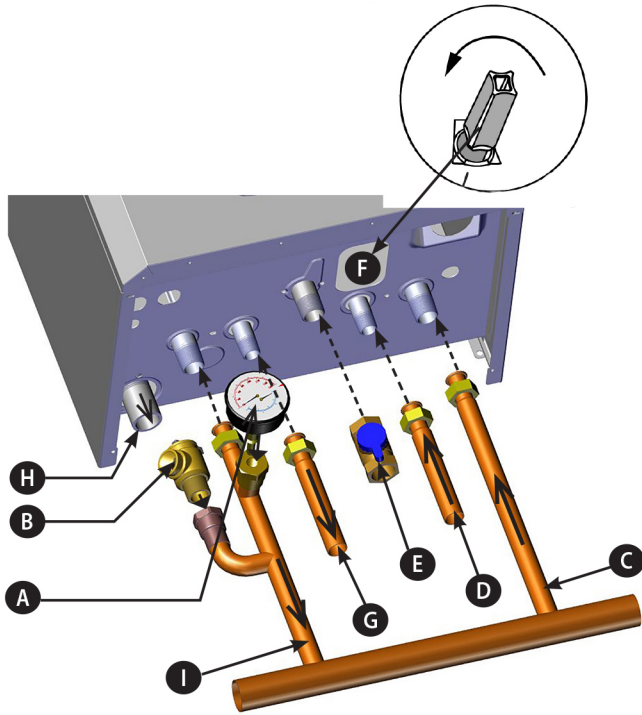


**MANIFOLD
165**

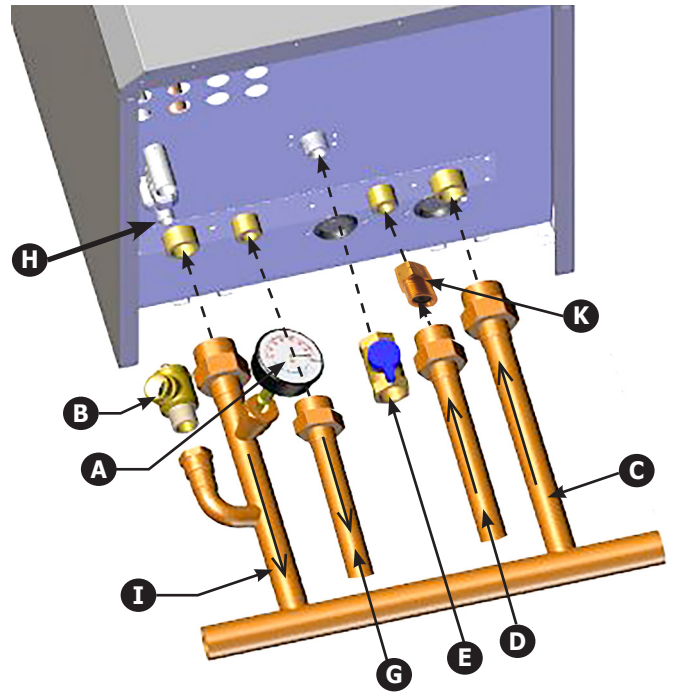


LABOR SAVING PIPING MANIFOLDS / NEAR BOILER PIPING CONNECTIONS

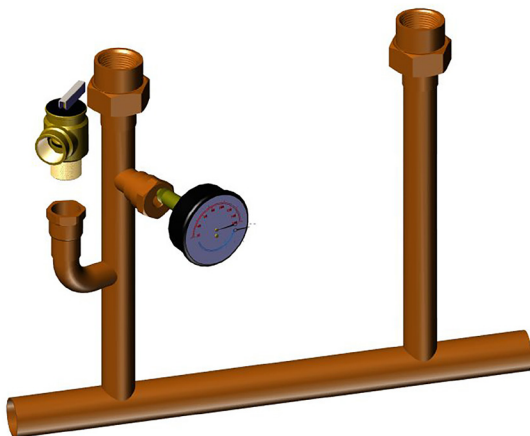
150 COMBI



205 COMBI



MANIFOLD 150/205



LEGEND		150	205
A	Pressure Gauge		-
B	Pressure Relief Valve	30.00 psi [2.11 bar]	
C	Heating return connection	3/4" [22.2mm]	1" [25.4mm]
D	Cold DHW inlet tap / system filling connection for Combi	1/2" [15.9mm]	3/4" [22.2mm]
E	Gas shutoff connection	3/4" [22.2mm]	
F	Boiler filling connection (some models)	1/2" [15.9mm]	na
G	DHW outlet/indirect storage tank connection	1/2" [15.9mm]	3/4" [22.2mm]
H	Drain connection for condensate	13/16" [21mm] ID Hose	3/4 NPT
I	Heating supply connection	3/4" [22.2mm]	1" [25.4mm]
K	5 gpm DHW flow restrictor (Factory installed) (205 only)	na	3/4" [22.2mm]

GENERAL INFORMATION - HYDRONIC PIPING

⚠ WARNING

Burn and scald hazard! Manufacturer requires installation of field supplied anti-scald valve. Failure to follow these instructions could result in death or serious injury.

General Information:

Piping installation, materials, and joining methods shall conform to requirements of authority having jurisdiction or in absence of such requirements:

- **USA** - National Fuel Gas Code, ANSI Z223.1/NFPA 54
- **Canada** - Natural Gas and Propane Installation Code, CAN/CSA B149.1

Manufacturer Requirements/Recommendations:

- Manufacturer requires all domestic hot water (DHW) installations use an anti-scald valve. Local codes may require additional equipment (expansion tank, relief valves, etc.) Select and size equipment to suit installation and meet code requirements.
- Use of a water filter on incoming water supply line.
- Manufacturer recommends use of a magnetic dirt separator in the hydronic system where there are cast iron or steel components, or where the previous boiler was a cast iron heat exchanger. The abrasive, extremely fine sediment is difficult to remove and can deposit onto heat exchanger surfaces and accumulate in pump cavities causing reduced efficiency and premature wear.
- If the piping manifold is not used the ASME temperature and pressure relief valve and temperature and pressure gauge shall be installed to conform to requirements of the authority having jurisdiction. Refer to appropriate manufacturer instructions for installation requirements.
- If the piping manifold is not used, a primary / secondary piping arrangement is manufacturer recommended. A maximum of 12" of separation between the supply and return pipe (closely spaced tees) of the boiler shall be maintained.
- Limit combined supply and return pipe lengths to maximum linear lengths of 20 ft (6.1 m) between boiler and closely spaced tees, when minimum 3/4" NPT pipe size is used. Linear length may be increased if supply and return pipe size is increased to limit pressure drop.

FOR YOUR SAFETY READ BEFORE OPERATING

⚠ DANGER



Hot Water Can Scald!

Water heated to temperature for clothes washing, dish washing and other sanitizing needs can scald and cause permanent injury. Children, elderly, and infirm or physically handicapped persons are more likely to be permanently injured by hot water. Never leave them unattended in bathtub or shower. Never allow small children to use a hot water tap or draw their own bath.

If anyone using hot water in the building fits the above description, or if state laws or local codes require certain water temperatures at hot water taps, you must take special precautions:

- Use lowest possible temperature setting.
- Install some type of tempering device, such as an automatic mixing valve, at hot water tap or water heater. Automatic mixing valve must be selected and installed according to manufacturer's recommendations and instructions.
- Water passing out of drain valves may be extremely hot. To avoid injury:
 - Make sure all connections are tight.
 - Direct water flow away from any person.

GENERAL INFORMATION - HYDRONIC PIPING

Water Temperature Setting	1st Degree Burn Exposure Time For An Adult	2nd and 3rd Degree Burn Exposure Time For An Adult
120° F	1 minute	5 minutes
130° F	5 seconds	30 seconds
140° F	2 seconds	5 seconds
150° F	1 second	1.5 seconds
160° F	Instantaneous	0.5 seconds

Note: Warning for Infants, Children, and Elderly: Great care must be taken when exposing the aforementioned groups to warm or hot water as they can be badly burned in exposure times less than half of the time for an adult.

Note → Provided Wiring and Piping illustrations are meant to show system concepts only. Installer is responsible for all equipment required by authority having jurisdiction.

Note → Arrange piping to prevent water dripping onto boiler.

All piping diagrams are shown with optional DHW Indirect Tank where applicable.

Use of Indirect Storage Tank (DHW):

Note → Sensors supplied with this boiler are proprietary to the manufacturer. Use of alternate sensors *WILL* diminish boiler performance.

- Use either DHW sensor or Indirect Tank Thermostat to interface with boiler. Wire to M2 terminals #9 and #10.
- Use of booster pump to increase flow rate to indirect tank is not recommended by manufacturer.
- Locate tank as close to boiler as possible.
- Size DHW tank, piping, and system to use only internal boiler pump.
- See available pump/flow rate chart, page 35 of this manual.
- Change P03 on boiler for application as specified on the wire diagram and Boiler Control section of Installation, Operation & Maintenance Manual supplied with the boiler.

The Labor Saver Piping Manifold, which is supplied with each boiler, is shown with most of the following piping diagrams.

GENERAL INFORMATION - WIRING

Electical Wiring Information:

All field wiring shall conform to the authority having jurisdiction or, in the absence of such requirements to:

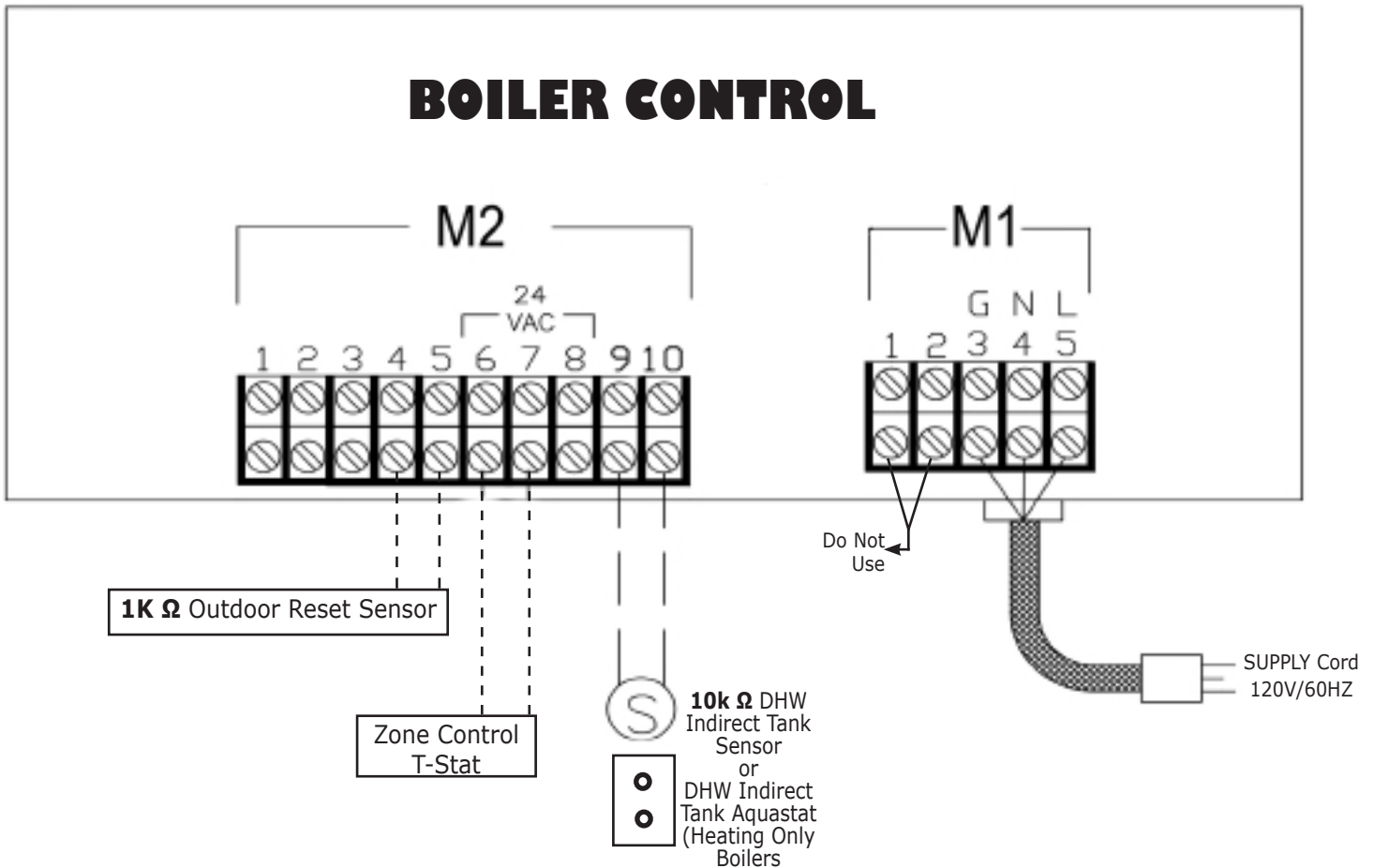
- **USA:** National Electrical Code, ANSI/NFPA 70,
- **Canada:** Canadian Electrical Code, Part I, CSA C22.1: Safety Standard for Electrical Installations.

Wiring diagrams shown in this manual utilize the ARGO™ Universal Control, the optional use of an Indirect Domestic Hot Water Tank, and optional use of a H2O Buffer Tank.

Reference the zone control manufacturer instruction manual for control operation and priority setting of DHW zones.

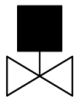
Note → **DO NOT** use 120 V thermostat terminals (m1- #1 and #2).

Note → Provided Wiring and Piping illustrations are meant to show system concepts only. Installer is responsible for all equipment required by authority having jurisdiction.



PIPING LEGEND

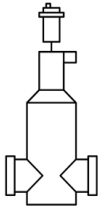
PIPING LEGEND



ZONE VALVE



BALL VALVE



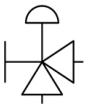
AIR SEPERATOR



CIRCULATOR



DRAIN



COMBINATION FILL



FLOW CHECK VALVE



BYPASS VALVE



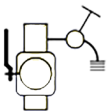
DIVERTER VALVE



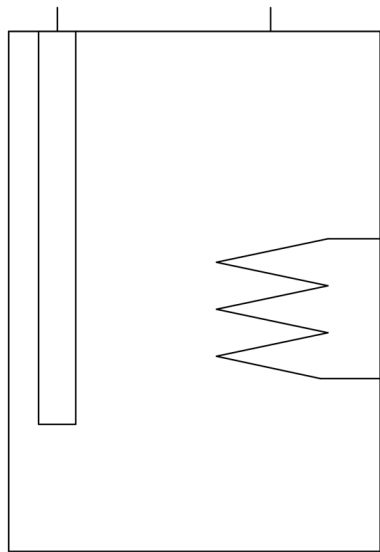
T&P OR RELIEF VALVE



THERMOSTATIC MIXING VALVE



PURGE VALVE



INDIRECT DHW TANK



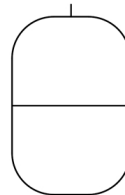
INDIRECT TANK AQUASTAT



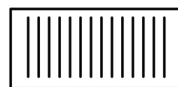
10K Ω INDIRECT DHW TANK SENSOR



TEMPERATURE & PRESSURE GAUGE



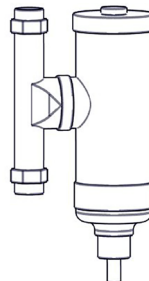
EXPANSION TANK



FLAT PLATE HEAT EXCHANGER
(COMBI ONLY)

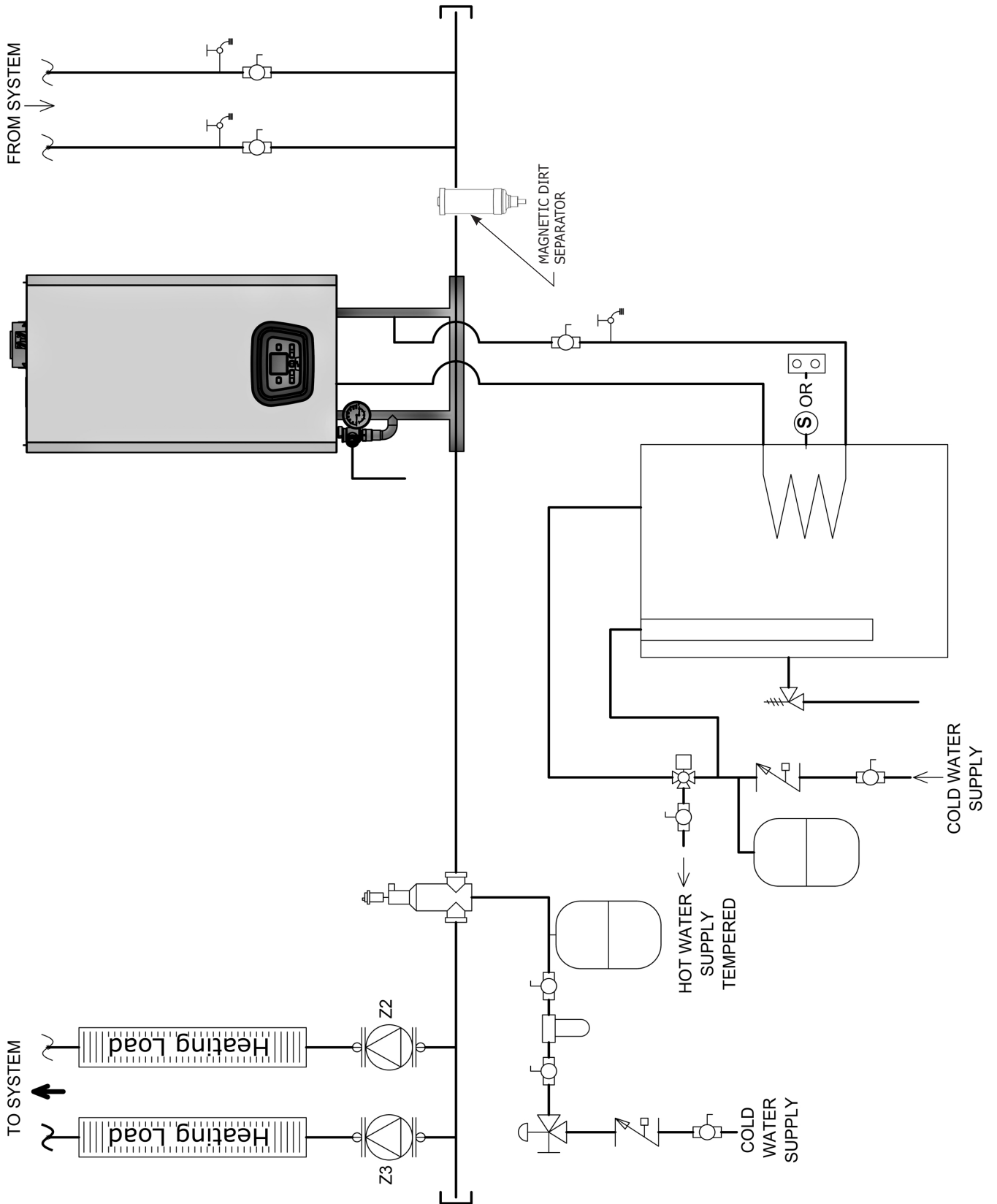


STRAINER

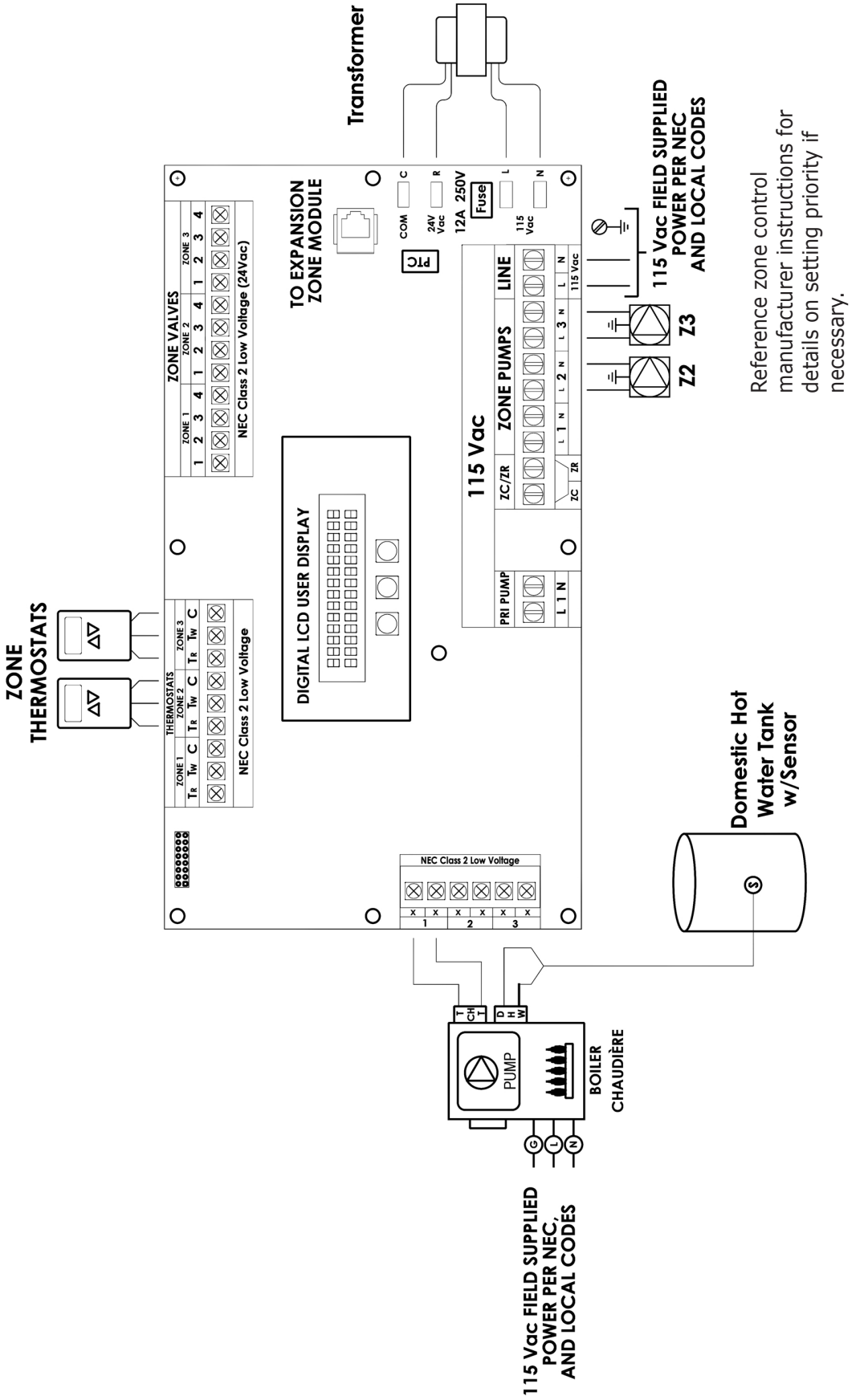


MAGNETIC DIRT SEPARATOR

125 with Zone Circulator Pumps



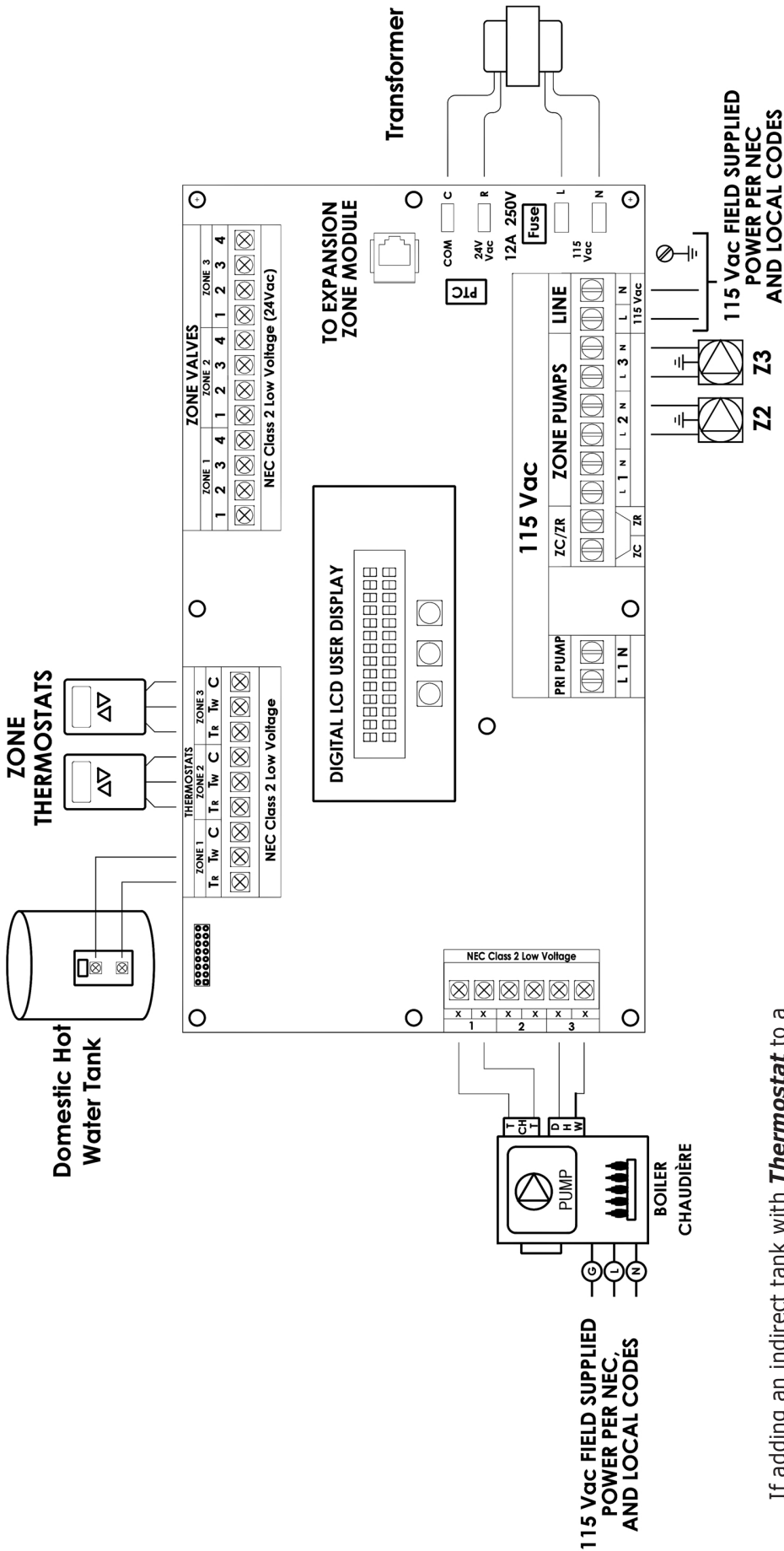
125 WITH INDIRECT ZONE PUMPS & DHW TANK W/ TANK SENSOR



Reference zone control manufacturer instructions for details on setting priority if necessary.

If adding an indirect tank with **sensor** to a **Heating Only Boiler**, change P03 from 08 to 05. See Section 9, Parameter Settings in Boiler Installation, Operation & Maintenance Manual for details.

125 W/ INDIRECT ZONE PUMPS & DHW TANK W/TANK T-STAT - WIRING DIAGRAM

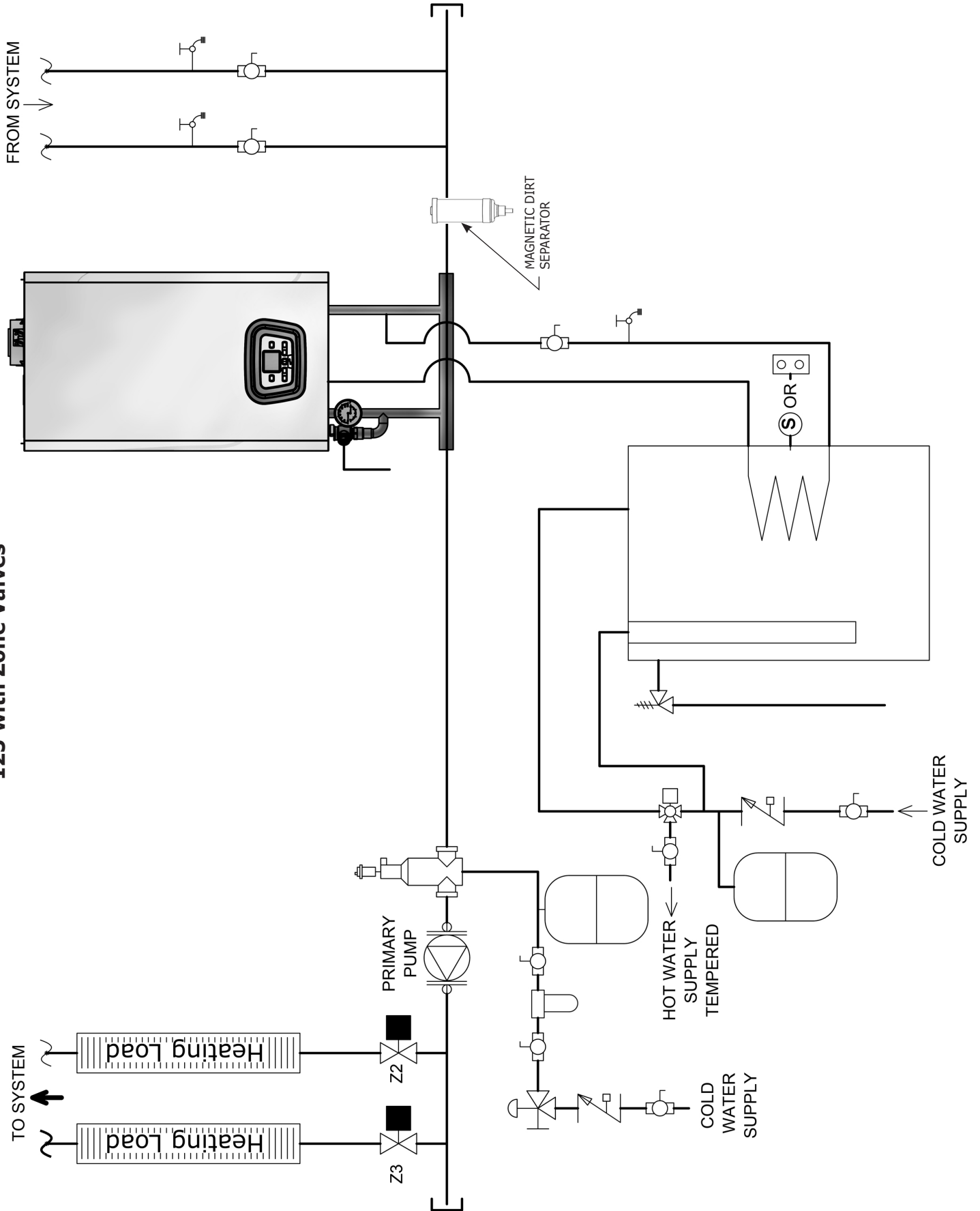


Reference zone control manufacturer instructions for details on setting priority if necessary.

If adding an indirect tank with **Thermostat** to a **Heating Only Boiler**, change P03 from 08 to 04. See Section 9, Parameter Settings in Boiler Installation, Operation & Maintenance Manual for details.

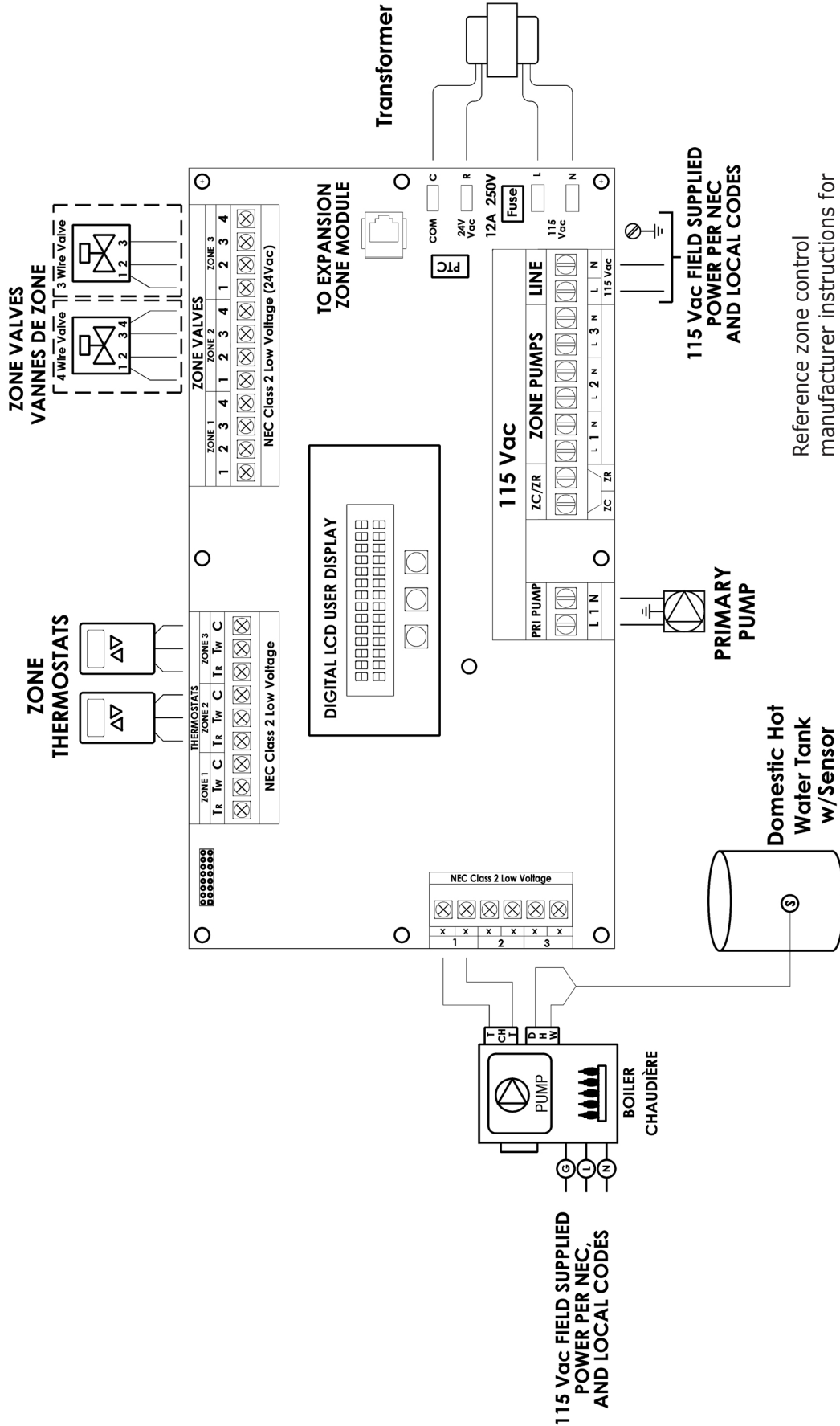
125 WITH ZONE VALVES - PIPING DIAGRAM

125 with Zone Valves



125 with Zone Valves

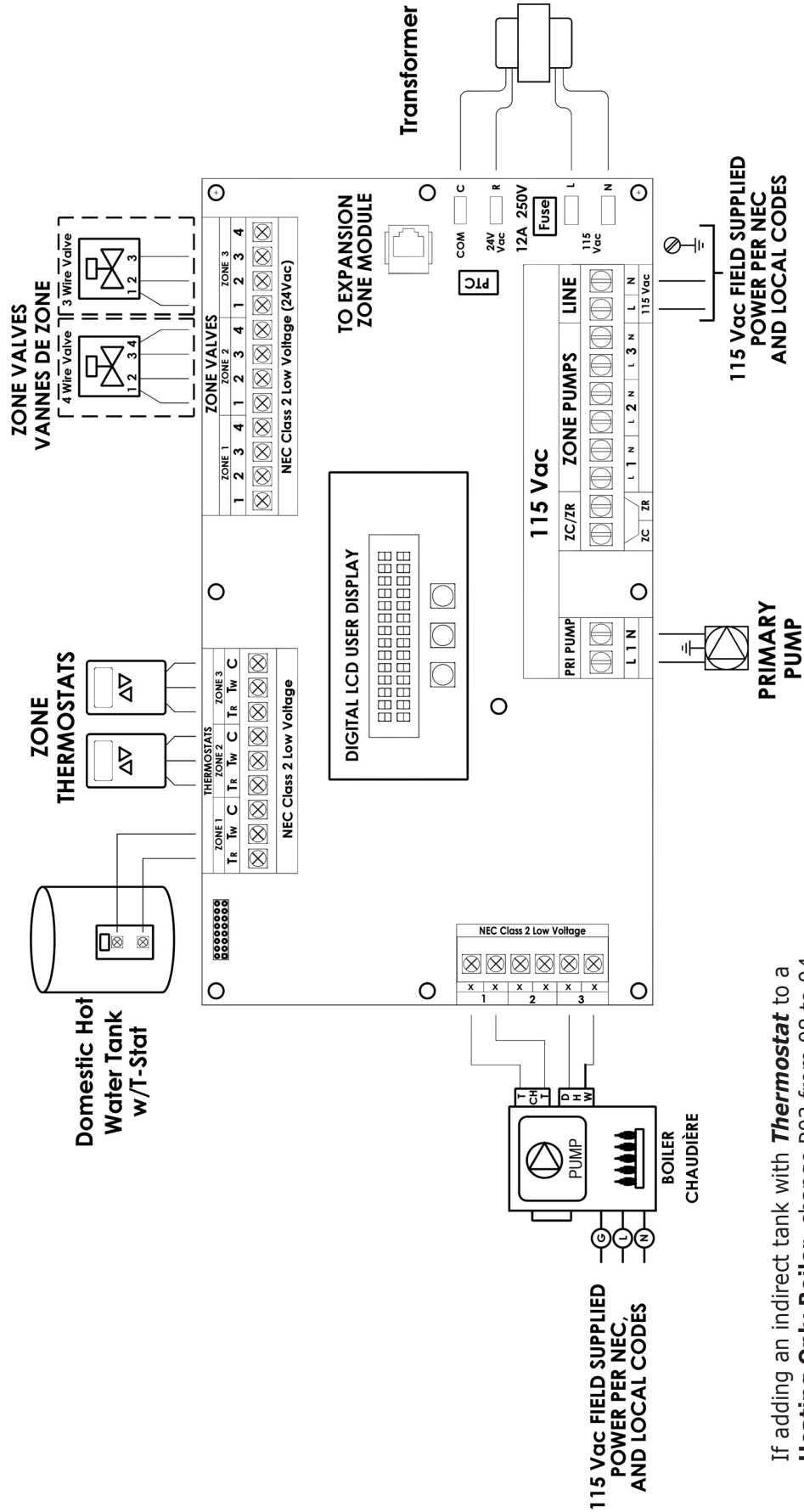
125 With Zone Valves, DHW Tank & Tank Sensor



If adding an indirect tank with **sensor** to a **Heating Only Boiler**, change P03 from 08 to 05. See Section 9, Parameter Settings in Boiler Installation, Operation & Maintenance Manual for details.

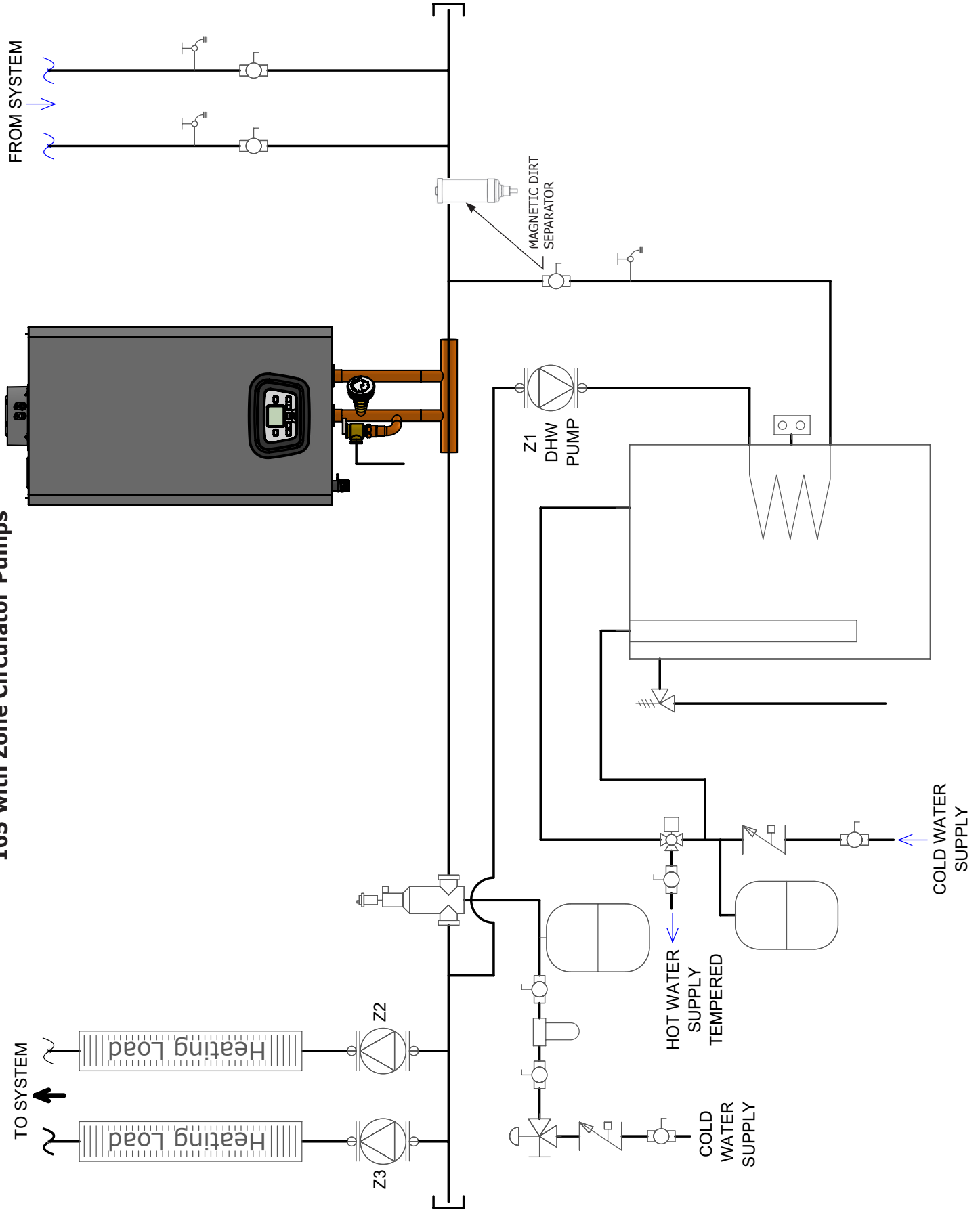
125 with Zone Valves

125 Indirect Zone Valves, DHW Tank, & Tank T-STAT

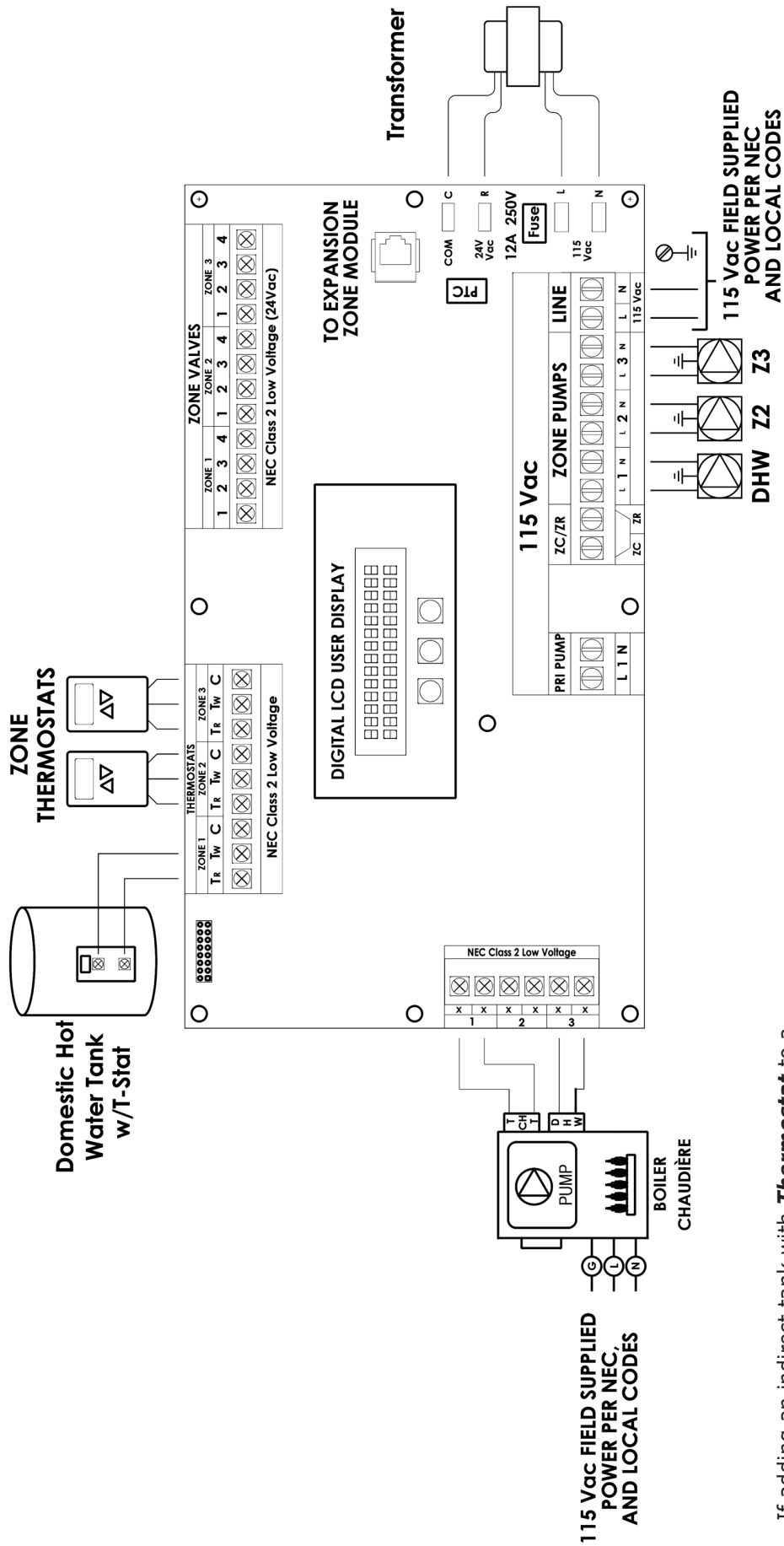


If adding an indirect tank with **Thermostat** to a **Heating Only Boiler**, change P03 from 08 to 04. See Section 9, Parameter Settings in Boiler Installation, Operation & Maintenance Manual for details.

165 with Zone Circulator Pumps



165 Indirect Zone Pumps, DHW Tank, Tank T-Stat

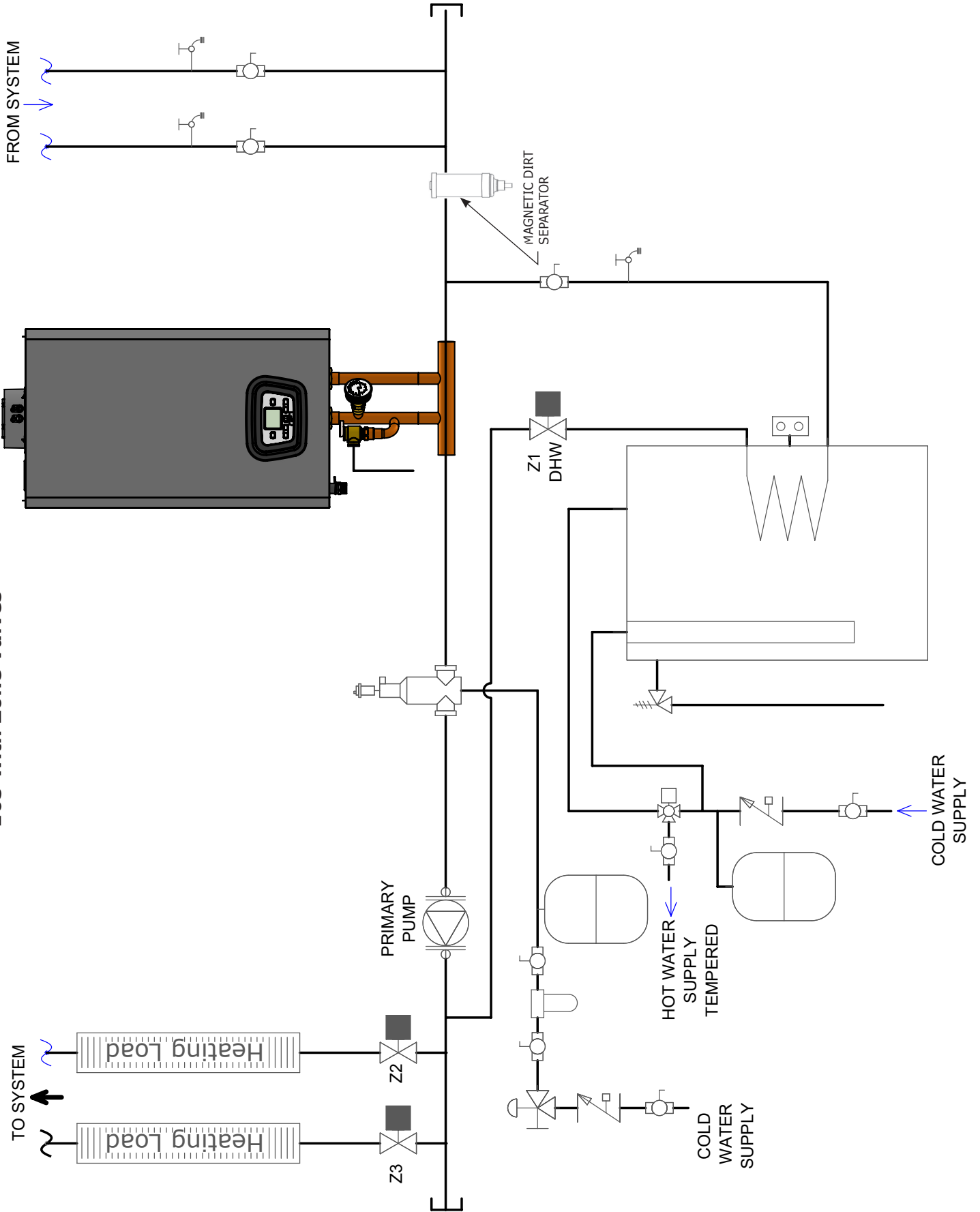


Reference zone control manufacturer instructions for details on setting priority if necessary.

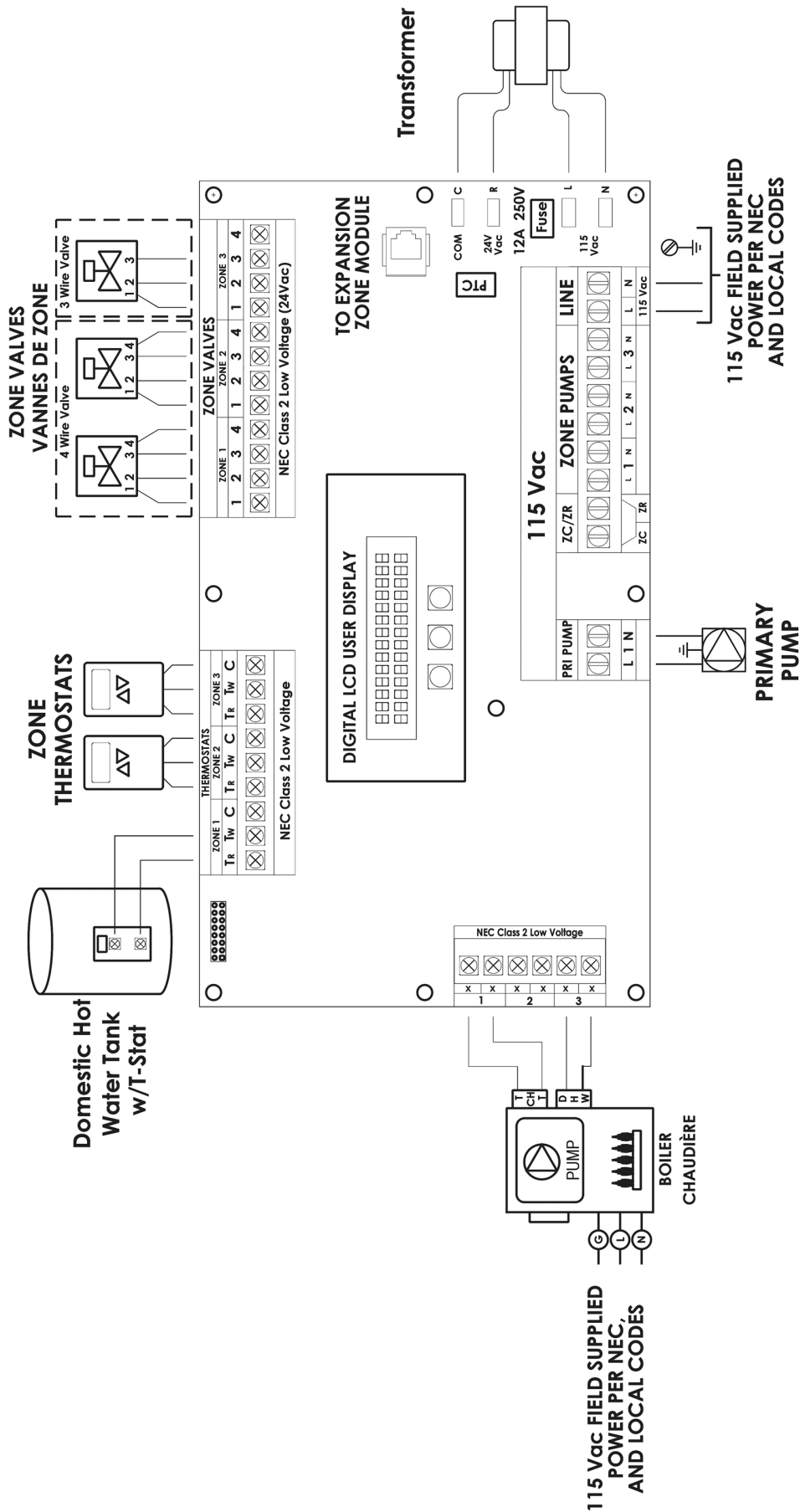
If adding an indirect tank with **Thermostat** to a **Heating Only Boiler**, change P03 from 08 to 04. See Section 9, Parameter Settings in Boiler Installation, Operation & Maintenance Manual for details.

165 WITH ZONE VALVES - PIPING DIAGRAM

165 with Zone Valves



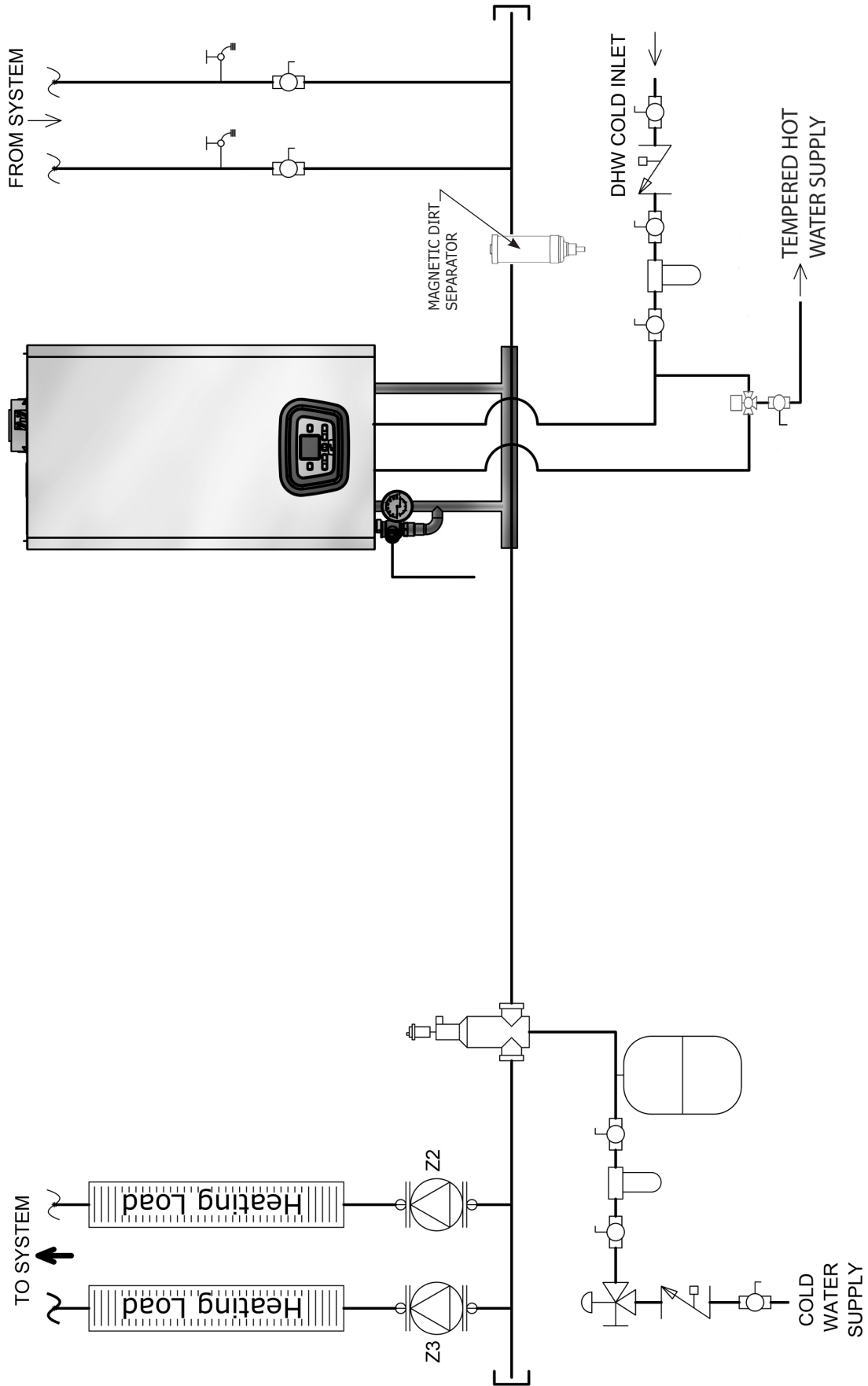
165 Indirect Zone Valves, DHW Tank, Tank T-STAT -Wiring Diagram



Reference zone control manufacturer instructions for details on setting priority if necessary.

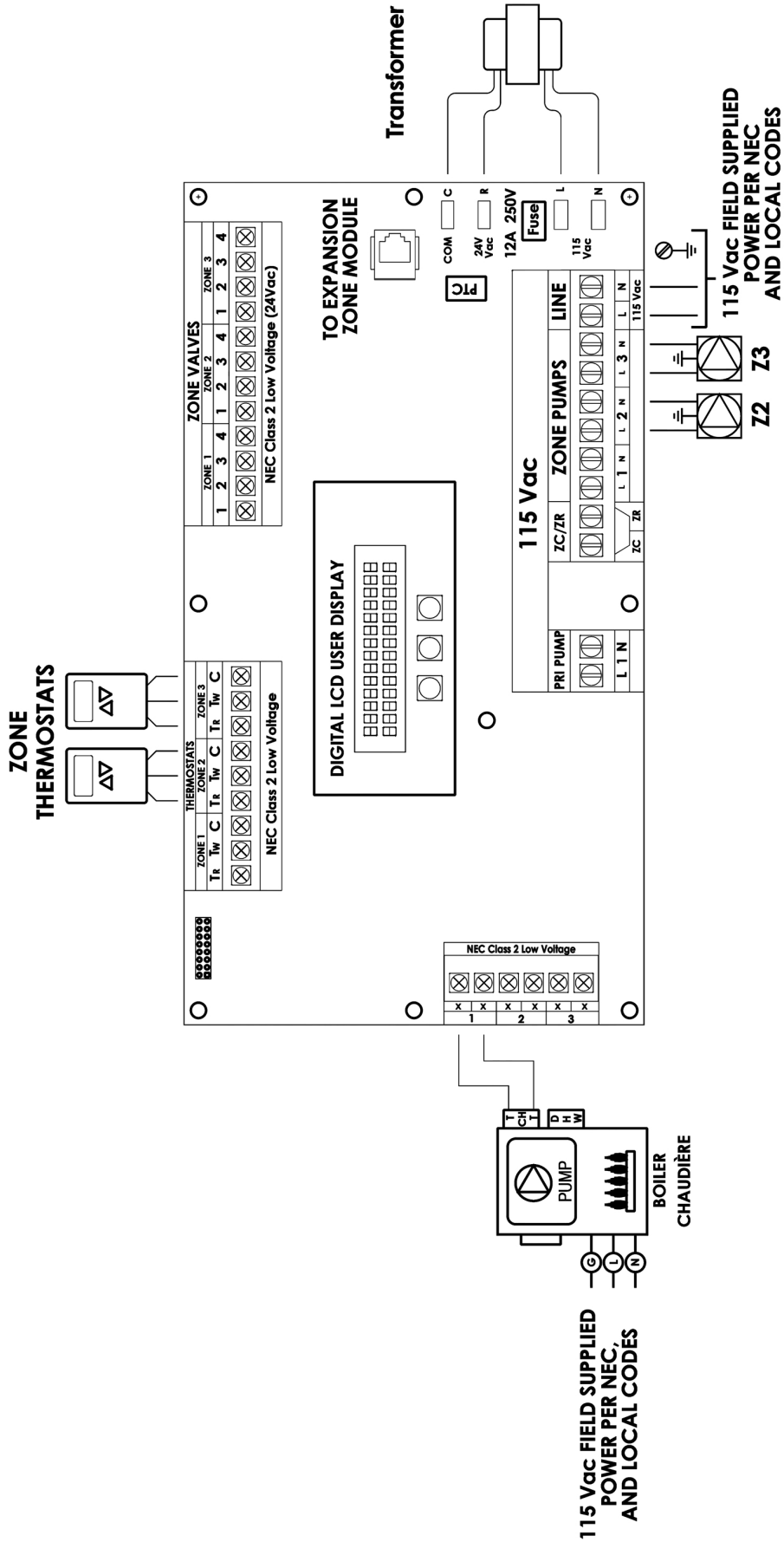
If adding an indirect tank with **Thermostat** to a **Heating Only Boiler**, change P03 from 08 to 04. See Section 9, Parameter Settings in Boiler Installation, Operation & Maintenance Manual for details.

150/205 with Zone Circulator Pumps

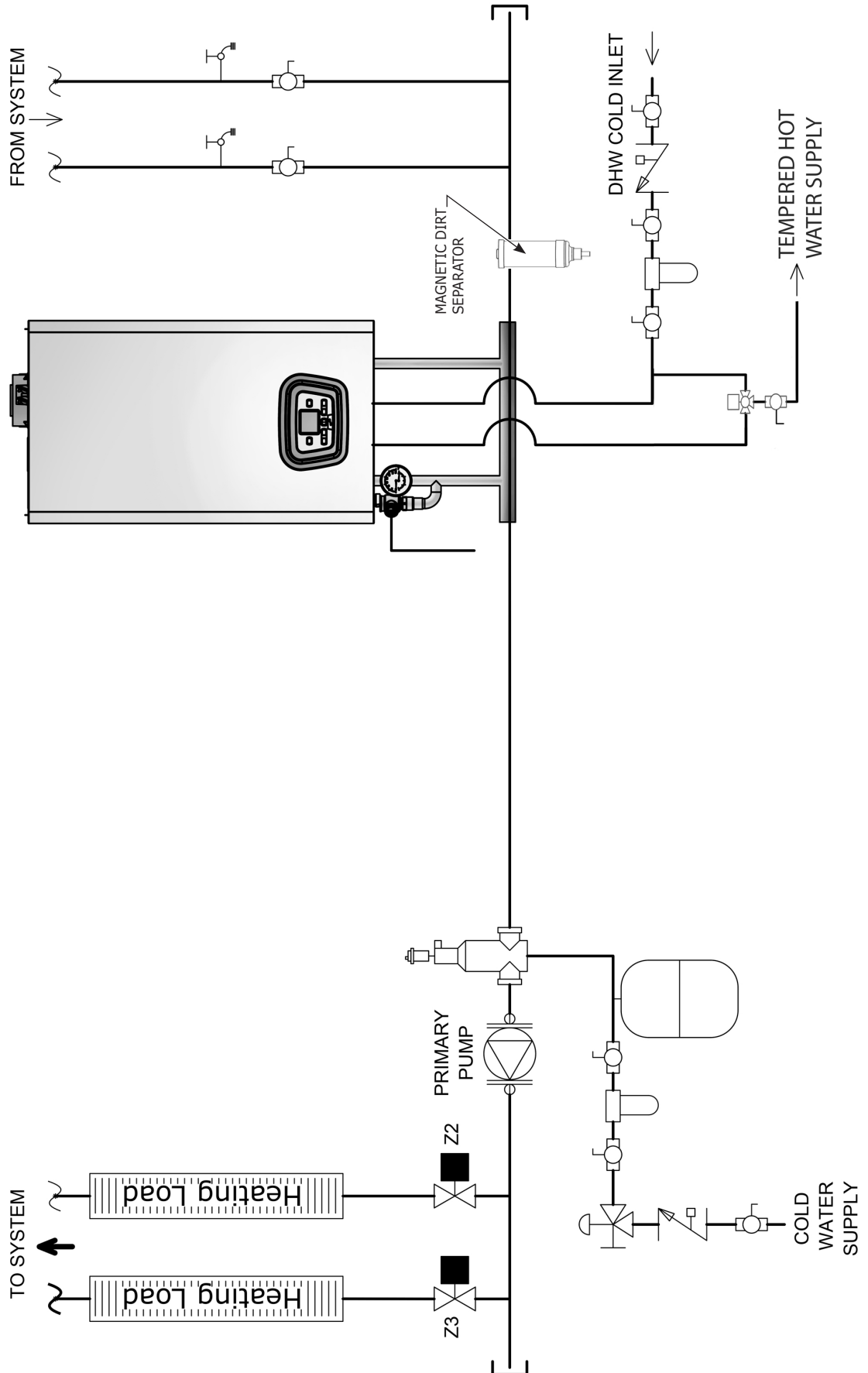


150 & 205 WITH ZONE PUMPS - WIRING DIAGRAM

150 & 205 With Zone Pumps

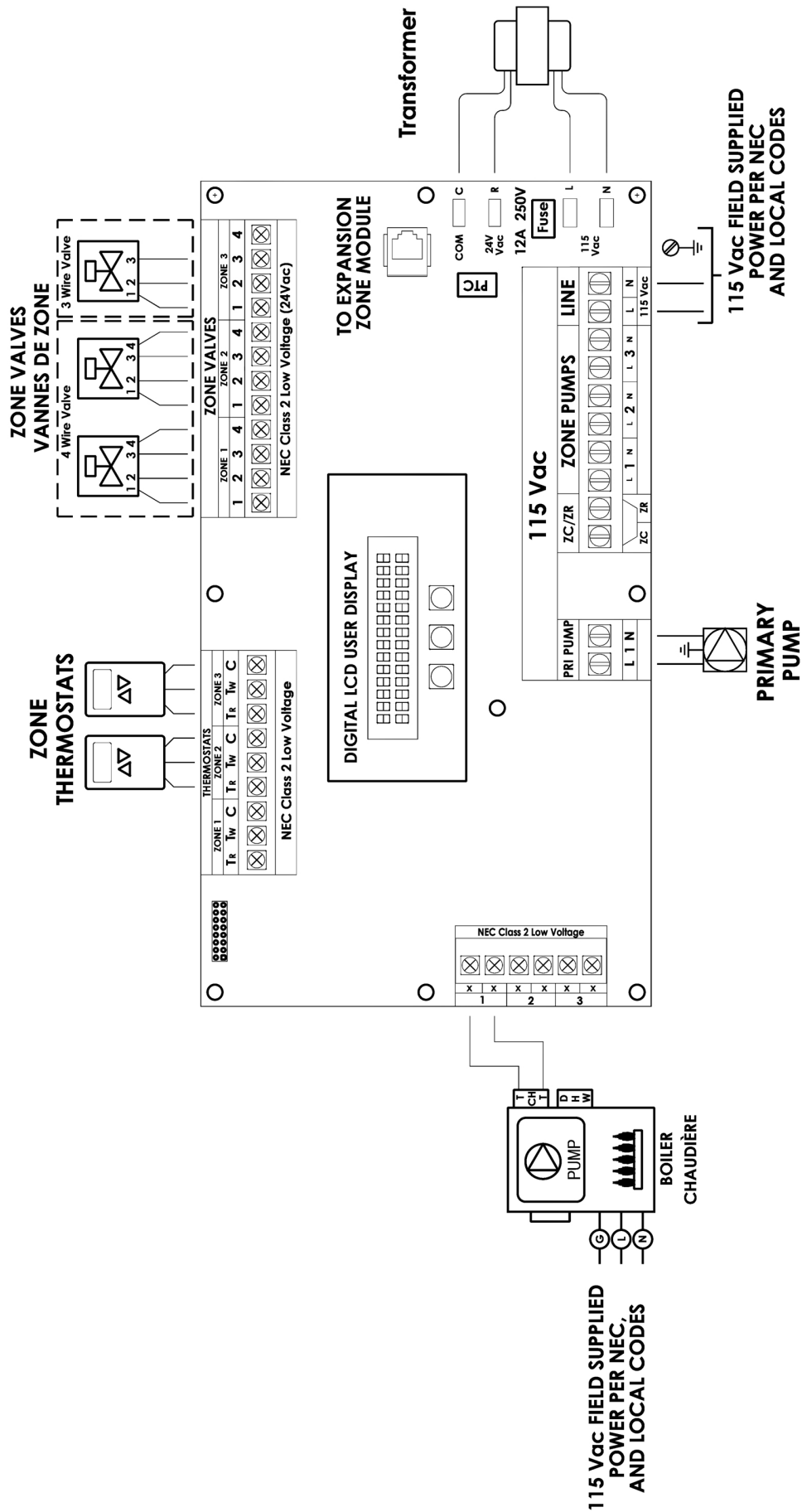


150 & 205 with Zone Valves



150 & 205 WITH ZONE VALVES - WIRING DIAGRAM

150 & 205 With Zone Valves



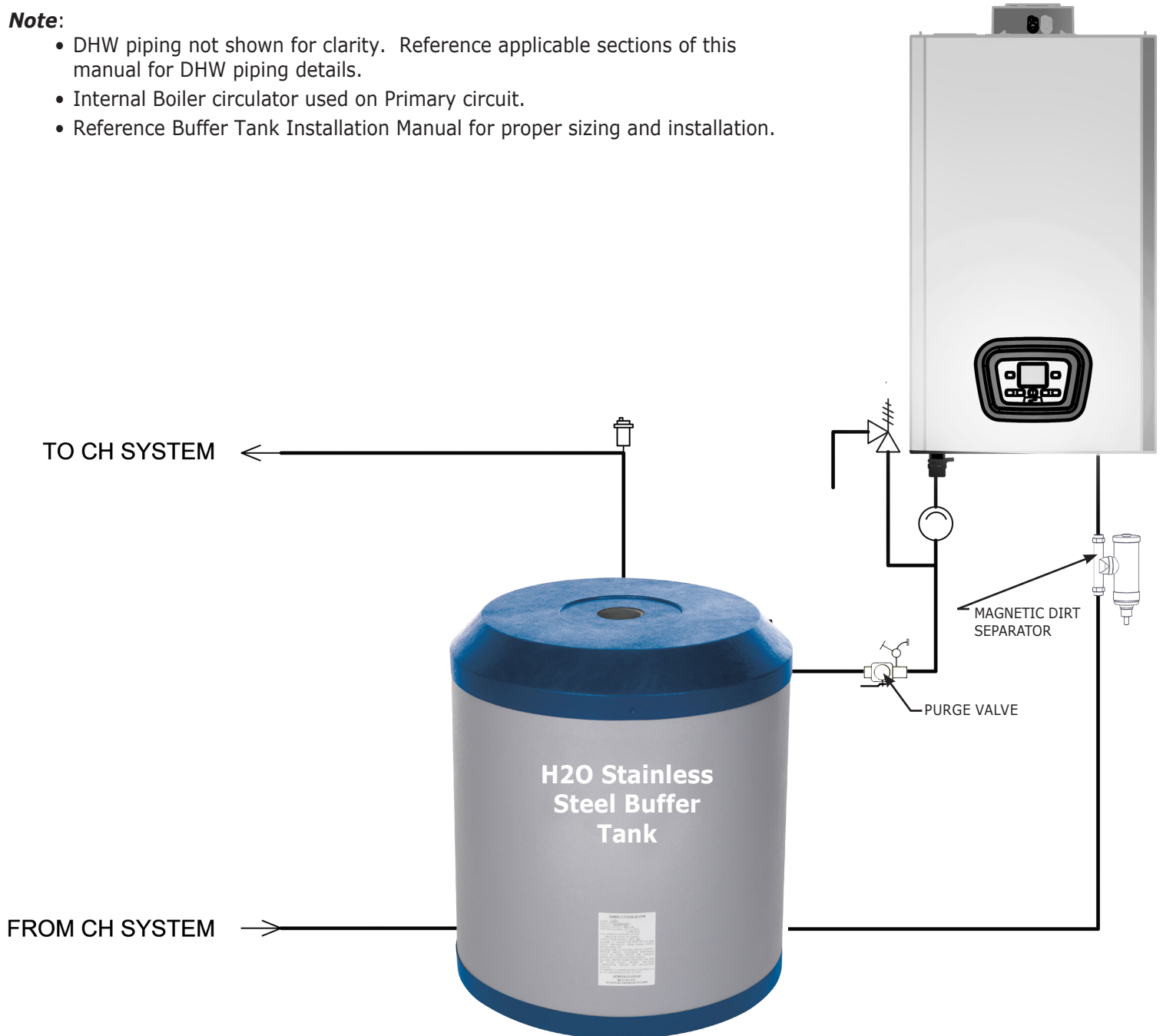
Low Mass Piping

When installing low mass systems, additional water mass may be required to avoid short cycling by the boiler. In these applications it is recommended that a buffer tank be installed.

Buffer Tank on Central Heat Circuit

Note:

- DHW piping not shown for clarity. Reference applicable sections of this manual for DHW piping details.
- Internal Boiler circulator used on Primary circuit.
- Reference Buffer Tank Installation Manual for proper sizing and installation.



Low Mass Boiler Wiring with Buffer Tank

Connect the buffer tank aquastat to terminals 6 and 7 on terminal block M2.

System wiring remains as shown in the previous wiring diagrams.



OPTIONAL EQUIPMENT

Optional Equipment

IMPORTANT: Sensors supplied with this boiler are proprietary to the manufacturer. Use of alternate market sensors *WILL* diminish boiler performance.

1. **1k Ω** Outdoor Air Sensor, if used.
 - A. Boiler automatically recognizes sensor when used.
 - B. See Chart 1 for sensor data. Sensor part number BD710487302V
 - C. Locate outdoor sensor to protect against wind and direct sunlight. Mounting instructions provided with sensor.
 - D. Maximum wire length is 100 ft (30m) for 22 ga. wire, or 150 ft (45m) for 18 ga. wire.
 - E. Connect wires to M2 OUTDOOR SENSOR terminals 4 & 5. Wires are interchangeable. See Accessories.

2. **10k Ω** Sensor for Indirect DHW Tank (Heating Only Boiler).
 - A. See Chart 2 for sensor data.
See Accessories section of this manual for wiring diagram.

CHART 1 -1k Ω OUTDOOR AIR SENSOR DATA			
T [°F]	R [Ohm]	T [°F]	R [Ohm]
-4.0	7,578	53.6	1,690
-2.2	7,193	55.4	1,621
-0.4	6,831	57.2	1,555
1.4	6,489	59.0	1,492
3.2	6,166	60.8	1,433
5.0	5,861	62.6	1,375
6.8	5,574	64.4	1,321
8.6	5,303	66.2	1,268
10.4	5,046	68.0	1,218
12.2	4,804	69.8	1,170
14.0	4,574	71.6	1,125
15.8	4,358	73.4	1,081
17.6	4,152	75.2	1,040
19.4	3,958	77.0	1,000
21.2	3,774	78.8	962
23.0	3,600	80.6	926
24.8	3,435	82.4	892
26.6	3,279	84.2	858
28.4	3,131	86.0	827
30.2	2,990	87.8	796
32.0	2,857	89.6	767
33.8	2,730	91.4	740
35.6	2,610	93.2	713
37.4	2,496	95.0	687
39.2	2,387	96.8	663
41.0	2,284	98.6	640
42.8	2,186	100.4	617
44.6	2,093	102.2	595
46.4	2,004	100.4	617
48.2	1,920	102.2	595
50.0	1,840	104.0	575
51.8	1,763	106.0	556

CHART 2 -10k Ω INDIRECT TANK SENSOR DATA			
T [°F]	R [Ohm]	T [°F]	R [Ohm]
32.0	32,505	86.0	8,060
33.8	30,898	87.8	7,726
35.6	29,381	89.6	7,407
37.4	27,946	91.4	7,103
39.2	26,590	93.2	6,813
41.0	25,308	95.0	6,537
42.8	24,094	96.8	6,273
44.6	22,946	98.6	6,021
46.4	21,859	100.4	5,781
48.2	20,829	102.2	5,551
50.0	19,854	104.0	5,332
51.8	18,930	105.8	5,123
53.6	18,054	107.6	4,923
55.4	17,223	109.4	4,732
57.2	16,436	111.2	4,549
59.0	15,689	113.0	4,374
60.8	14,980	114.8	4,207
62.6	14,306	116.6	4,047
64.4	13,667	118.4	3,894
66.2	13,060	120.2	3,748
68.0	12,483	122.0	3,608
69.8	11,935	123.8	3,473
71.6	11,414	125.6	3,345
73.4	10,919	127.4	3,222
75.2	10,447	129.2	3,104
77.0	9,999	131.0	2,991
78.8	9,572	132.8	2,882
80.6	9,166	134.6	2,778
82.4	8,779	136.4	2,679
84.2	8,411	138.2	2,583

ACCESSORIES

Accessories:

1. 1k Ω Outdoor Temperature Sensor Kit - BD710487302V

Use Outdoor Sensor Kit with Heating Only or Combi Boilers. Wire Control to boiler M2 terminal strip terminals #4 and #5 as shown below.

Install/locate Control according to instructions supplied with sensor kit and Installation, Operation and Maintenance Manual (IOM).

Setting "Kt" Climate Curve:

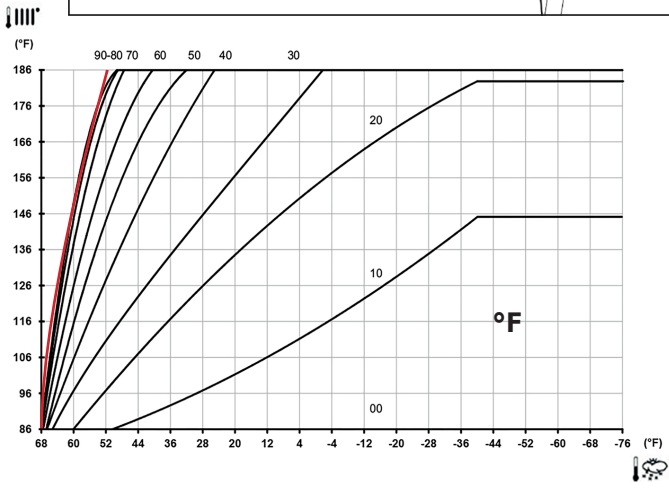
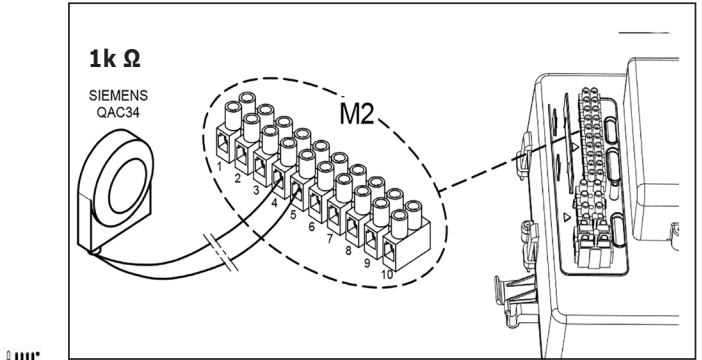
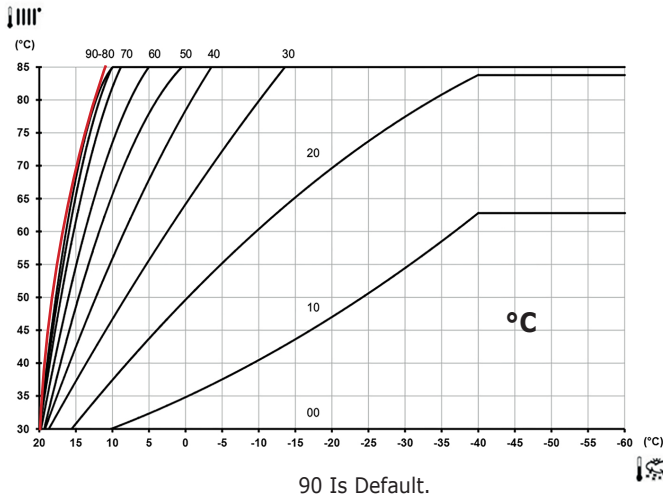
Start boiler in CH mode. Depress CH control button once.



Boiler control will recognize installed OAS sensor. Display will change to show current default "Kt" value. Note display value.

When operation in CH mode, Kt value setting will override maximum CH boiler control set point based on current outdoor temperature.

- Refer to applicable °F (or °C) chart,
- Identify Kt range that will satisfy the desired boiler delivery temperature based on average (extreme) outdoor temperature range expected for climate location.



- Use lower value of range as the desired Kt value.
(example): to deliver 186°F water @ OT of -20°F = Kt range is 90 thru 25. Select 25.
- To change "default" Kt value on boiler control use +/- CH Heating buttons.

When scrolling has stopped, boiler will automatically "SAVE" value as new Kt default value and automatically return to CH mode when no Kt adjustment activity is sensed. Kt values can be changed in +/- 1 point increments.

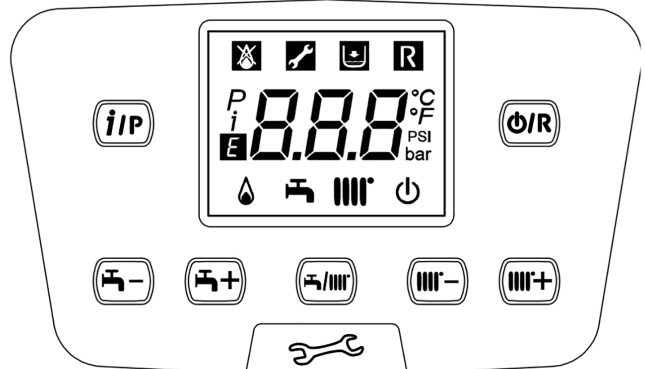
To return to check or change current Kt "default value" - depress one of the CH setpoint adjustment buttons (once), while in any heating or standby mode. Adjust Kt value to obtain desired comfort level.

Note For temperatures below -40°F (-40°C), maximum heating flow temperature set point no longer increases and curves on the graph become horizontal.

BUTTONS Key

	DHW temperature adjustment (+ to increase the temperature and - to decrease it)
	Heating water temperature adjustment (+ to increase the temperature and - to decrease it)
	Boiler operating information
	Operating mode: DHW – DHW & Heating – Heating Only
	Off – Reset – Exit menu/functions

Boiler Control Panel





ACCESSORIES

2. 10k Ω Indirect Storage Tank Sensor Kit

Heating Only boiler can be electrically connected to Indirect Storage Tank.

Diagram of hydraulic connection of external indirect storage tank is shown below.

Connect DHW priority sensor to terminals #9 and #10 on terminal block M2. The element of the sensor must be inserted in the sensor well located on the indirect storage tank.

Verify the exchange capacity of the storage boiler coil is appropriate for power of the boiler. Adjust DHW temperature (+95°F...+140°F / +35°C...+60°C) by pressing   buttons on boiler control panel.

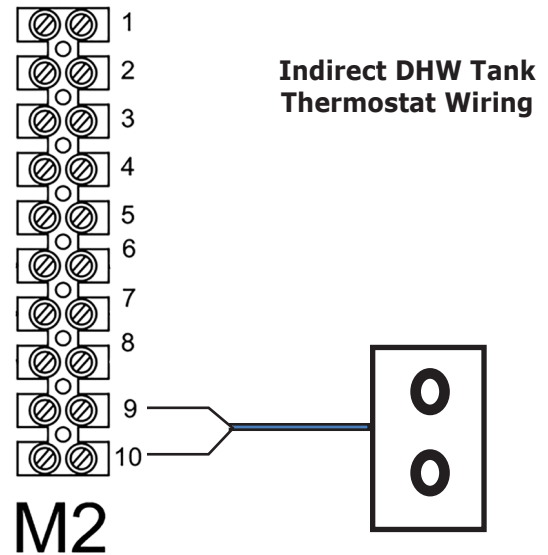
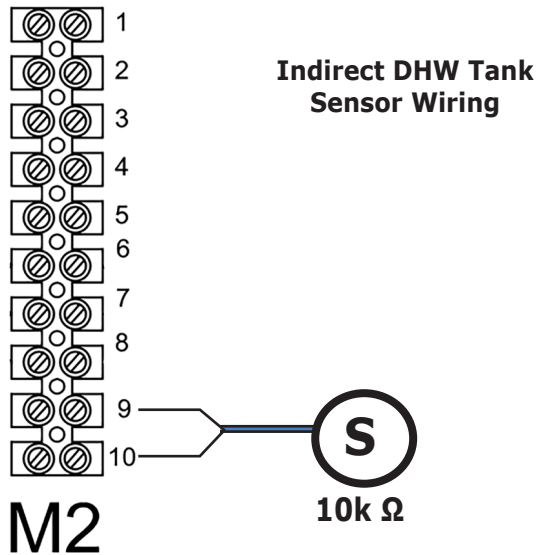
Note → Parameter PO3 for **Heating Only** boiler, with no indirect tank remains Factory Set at 08. No change is required.

If adding an Indirect Tank with a sensor to **Heating Only Boiler** - change PO3 parameter from 08 to 05.






If adding an Indirect Tank with a thermostat to **Heating Only Boiler** - change PO3 parameter from 08 to 04.

See Section 9, Parameter Settings, in boiler's Installation, Operation, and Maintenance Manual.

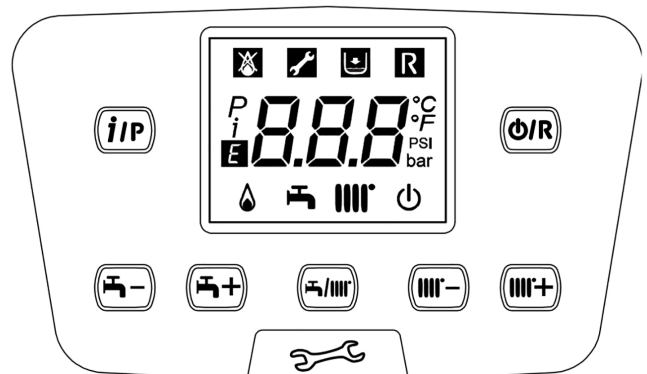
Parameter PO3 for **COMBI** boiler factory set at 00 requires no change.



BUTTONS Key

	DHW temperature adjustment (+ to increase the temperature and - to decrease it)
	Heating water temperature adjustment (+ to increase the temperature and - to decrease it)
	Boiler operating information
	Operating mode: DHW – DHW & Heating – Heating Only
	Off – Reset – Exit menu/functions

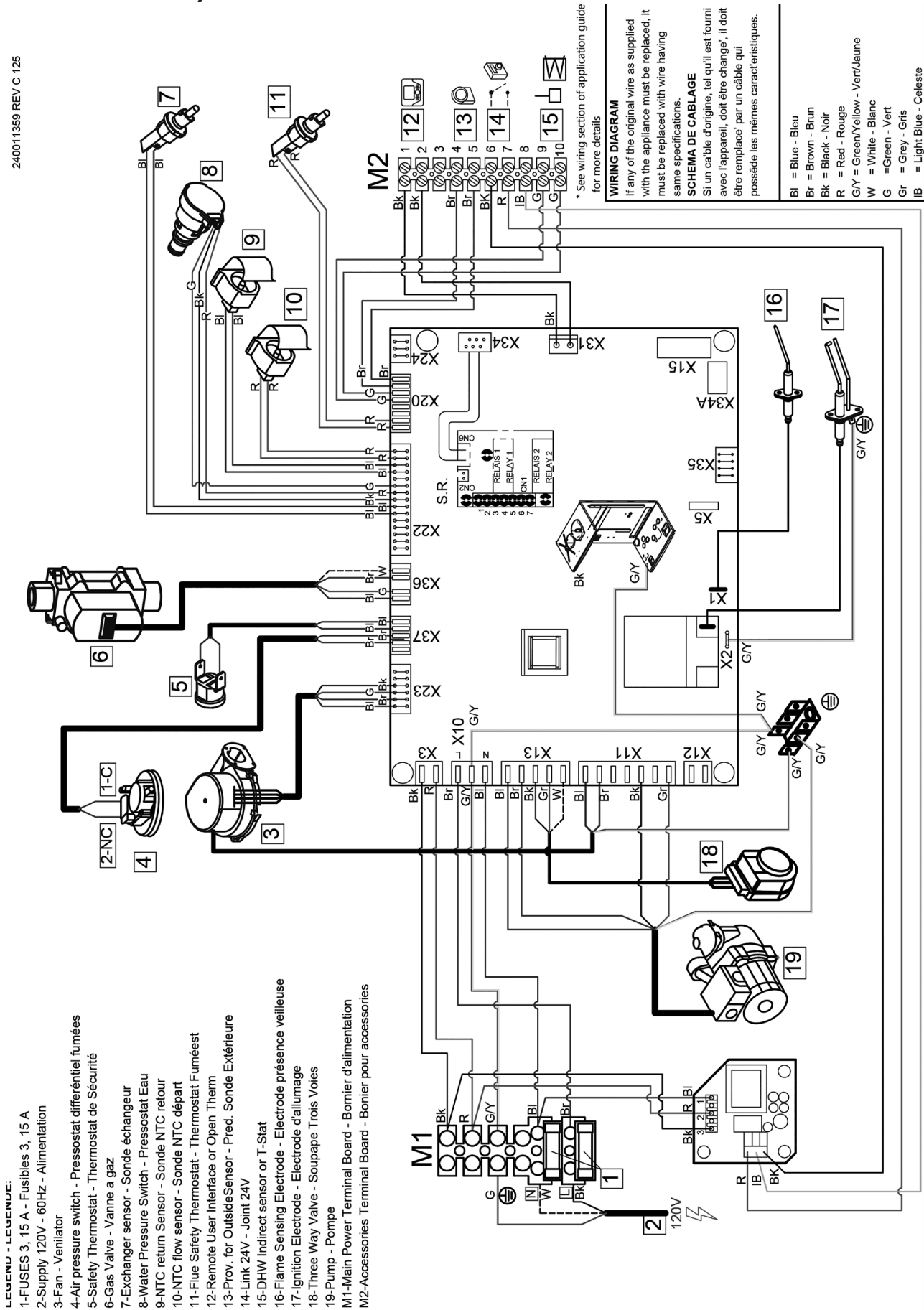
Boiler Control Panel



125 - HEAT ONLY WIRING DIAGRAM

MODEL 125 - Heat Only

240011359 REV C 125



LEGENU - LEGENDE:

- 1-FUSES 3, 15 A - Fusibles 3, 15 A
- 2-Supply 120V - 60Hz - Alimentation
- 3-Fan - Ventilator
- 4-Air pressure switch - Pressostat différentiel fumées
- 5-Safety Thermostat - Thermostat de Sécurité
- 6-Gas Valve - Vanne a gaz
- 7-Exchanger sensor - Sonde échangeur
- 8-Water Pressure Switch - Pressostat Eau
- 9-NTC return Sensor - Sonde NTC retour
- 10-NTC flow sensor - Sonde NTC départ
- 11-Flue Safety Thermostat - Thermostat Fumées
- 12-Remote User Interface or Open Therm
- 13-Link 24V - Joint 24V
- 14-DHW Indirect sensor or T-Stat
- 15-Flame Sensing Electrode - Electrode présence veilleuse
- 16-Ignition Electrode - Electrode d'allumage
- 17-Three Way Valve - Soupape Trois Voies
- 18-Pump - Pompe
- M1-Main Power Terminal Board - Bornier d'alimentation
- M2-Accessories Terminal Board - Bornier pour accessoires

* See wiring section of application guide for more details

WIRING DIAGRAM

If any of the original wire as supplied with the appliance must be replaced, it must be replaced with wire having same specifications.

SCHEMA DE CABLAGE

Si un câble d'origine, tel qu'il est fourni avec l'appareil, doit être changé, il doit être remplacé par un câble qui possède les mêmes caractéristiques.

- BI = Blue - Bleu
- Br = Brown - Brun
- Bk = Black - Noir
- R = Red - Rouge
- G/Y = Green/Yellow - Vert/Jaune
- W = White - Blanc
- G = Green - Vert
- Gr = Grey - Gris
- IB = Light Blue - Celeste

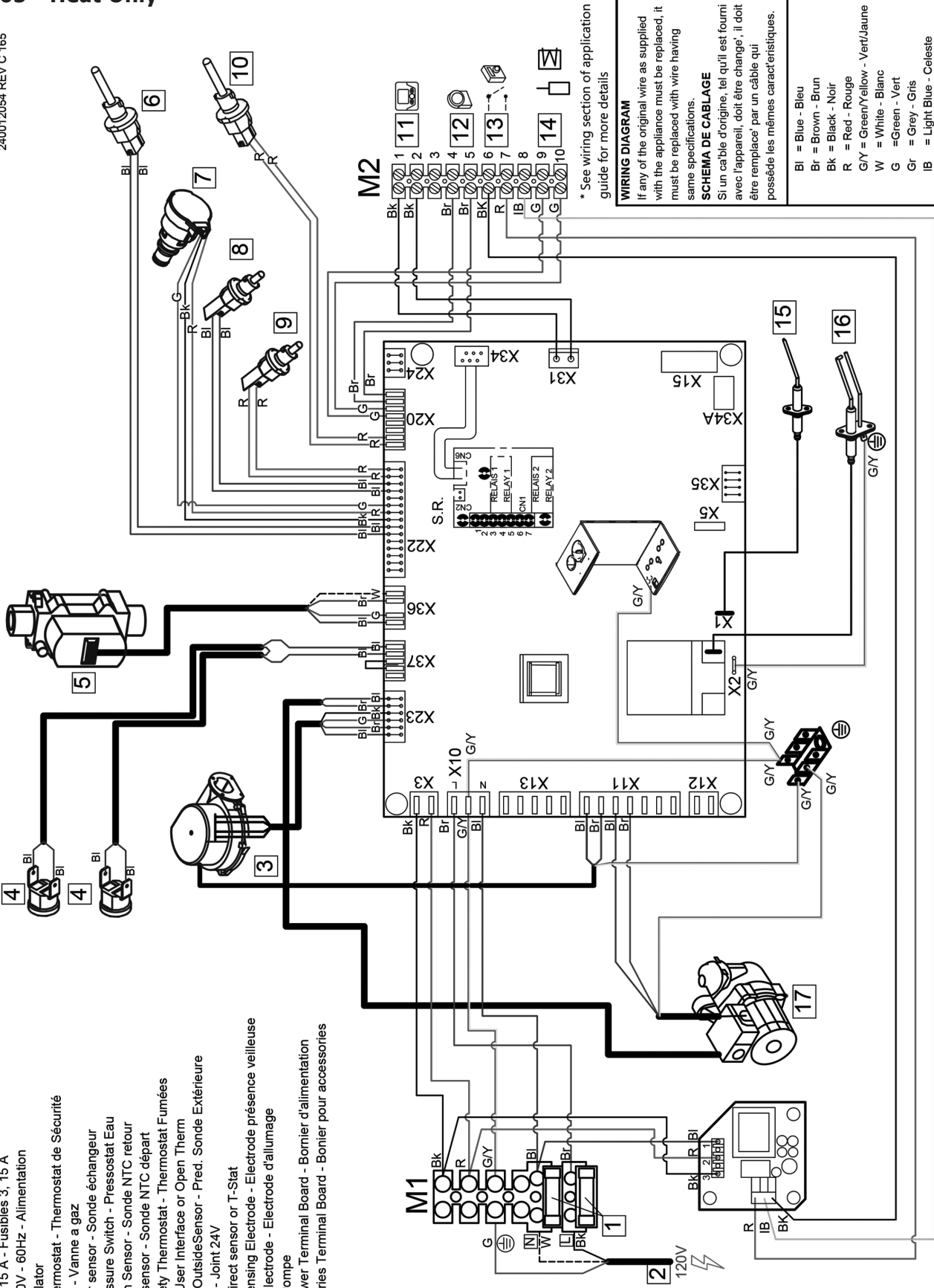
165 - HEAT ONLY WIRING DIAGRAM

MODEL 165 - Heat Only

240012054 REV C 165

LEGEND - LEGENDE:

- 1-FUSES 3, 15 A - Fusibles 3, 15 A
- 2-Supply 120V - 60Hz - Alimentation
- 3-Fan - Ventilator
- 4-Safety Thermostat - Thermostat de Sécurité
- 5-Gas Valve - Vanne a gaz
- 6-Exchanger sensor - Sonde échangeur
- 7-Water Pressure Switch - Pressostat Eau
- 8-NTC return Sensor - Sonde NTC retour
- 9-NTC flow sensor - Sonde NTC départ
- 10-Flue Safety Thermostat - Thermostat Fumées
- 11-Remote User Interface or Open Therm
- 12-Prov. for OutsideSensor - Pred. Sonde Extérieure
- 13-Link 24V - Joint 24V
- 14-DHW Indirect sensor or T-Stat
- 15-Flame Sensing Electrode - Electrode présence veilleuse
- 16-Ignition Electrode - Electrode d'allumage
- 17-Pump - Pompe
- M1-Main Power Terminal Board - Bornier d'alimentation
- M2-Accessories Terminal Board - Bornier pour accessoires



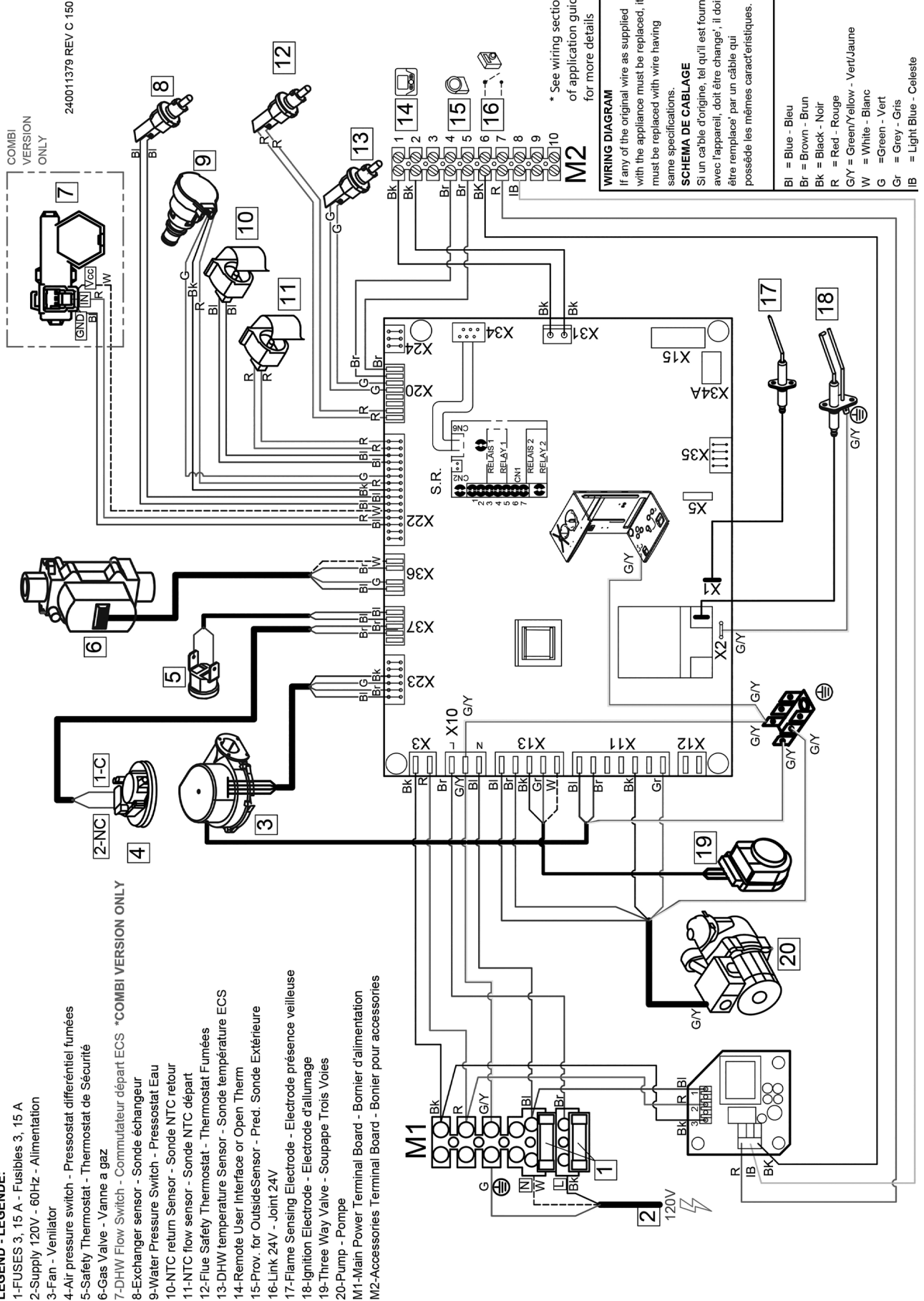
WIRING DIAGRAM
 If any of the original wire as supplied with the appliance must be replaced, it must be replaced with wire having same specifications.
SCHEMA DE CABLAGE
 Si un câble d'origine, tel qu'il est fourni avec l'appareil, doit être changé, il doit être remplacé par un câble qui possède les mêmes caractéristiques.

- BI = Blue - Bleu
- Br = Brown - Brun
- Bk = Black - Noir
- R = Red - Rouge
- G/Y = Green/Yellow - Vert/Jaune
- W = White - Blanc
- G = Green - Vert
- Gr = Grey - Gris
- IB = Light Blue - Celeste

* See wiring section of application guide for more details

150 - COMBI WIRING DIAGRAM

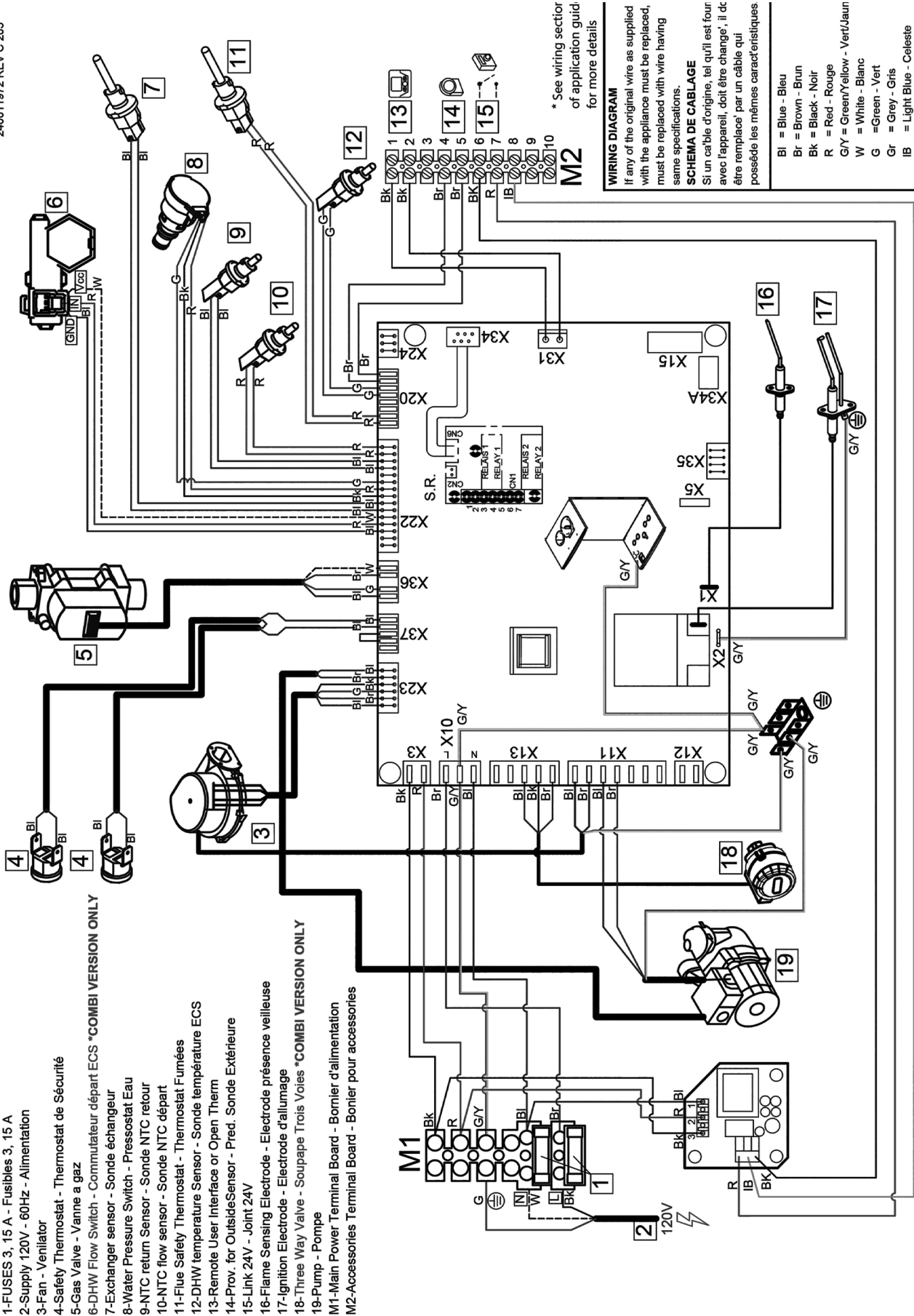
MODEL 150 - Combi



205 - COMBI WIRING DIAGRAM

MODEL 205 - Combi

240011972 REV C 205



LEGEND - LEGENDE:

- 1-FUSES 3, 15 A - Fusibles 3, 15 A
- 2-Supply 120V - 60Hz - Alimentation
- 3-Fan - Ventilator
- 4-Safety Thermostat - Thermostat de Sécurité
- 5-Gas Valve - Vanne a gaz
- 6-DHW Flow Switch - Commutateur départ ECS *COMBI VERSION ONLY
- 7-Exchanger sensor - Sonde échangeur
- 8-Water Pressure Switch - Pressostat Eau
- 9-NTC return sensor - Sonde NTC retour
- 10-NTC flow sensor - Sonde NTC départ
- 11-Flue Safety Thermostat - Thermostat Fumées
- 12-DHW Temperature Sensor - Sonde température ECS
- 13-Remote User Interface or Open Therm
- 14-Prev. for OutsideSensor - Pred. Sonde Extérieure
- 15-Link 24V - Joint 24V
- 16-Flame Sensing Electrode - Electrode présence veilleuse
- 17-Ignition Electrode - Electrode d'allumage
- 18-Three Way Valve - Soupape Trois Voies *COMBI VERSION ONLY
- 19-Pump - Pompe
- M1-Main Power Terminal Board - Bornier d'alimentation
- M2-Accessories Terminal Board - Bornier pour accessoires

* See wiring sector of application guide for more details

WIRING DIAGRAM

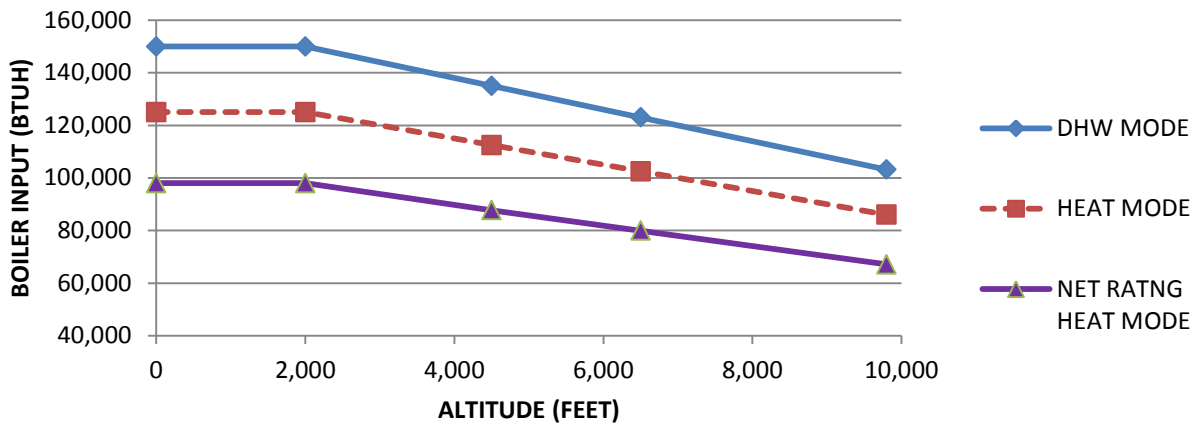
If any of the original wire as supplied with the appliance must be replaced, must be replaced with wire having same specifications.

SCHEMA DE CABLAGE

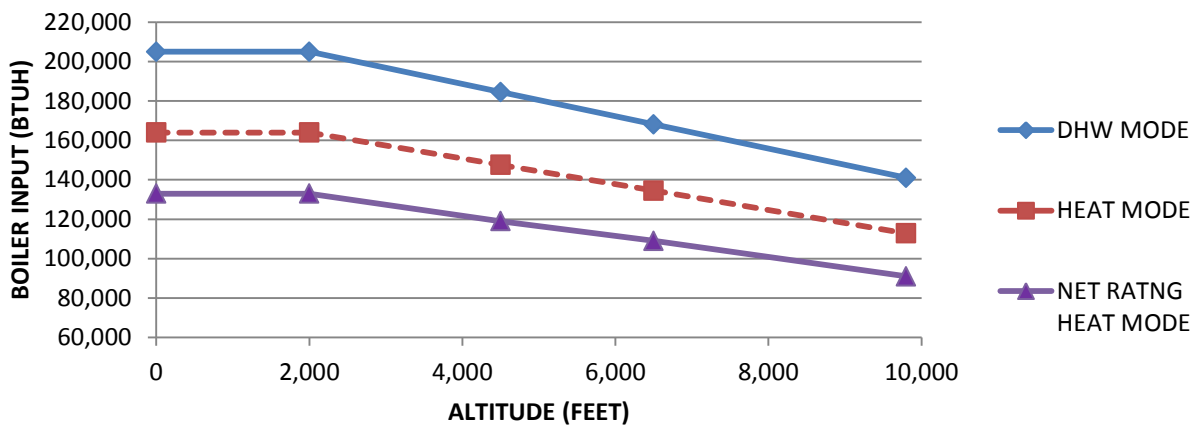
Si un câble d'origine, tel qu'il est four avec l'appareil, doit être change, il dc être remplacé par un câble qui possède les mêmes caractéristiques.

- Bl = Blue - Bleu
- Br = Brown - Brun
- Bk = Black - Noir
- R = Red - Rouge
- GY = Green/Yellow - Vert/Jaun
- W = White - Blanc
- G = Green - Vert
- Gr = Grey - Gris
- IB = Light Blue - Celeste

MODELS 125/150
CALCULATED EFFECTS OF HI-ALTITUDE ON BOILER
PERFORMANCE



MODELS 165/205
CALCULATED EFFECTS OF HI-ALTITUDE ON BOILER
PERFORMANCE



'HEATING ONLY' BOILER (125,000 BTUH)

		BOILER OUTPUT (BTUH/HR)			
		50,000	60,000	80,000	100,000
H2O30					
1st HOUR RATING (GAL/HR)	140 F	94	106	106	106
	115 F	119	138	158	158
CONTINUOUS RATING (GAL/HR)	140 F	67	79	79	79
	115 F	92	111	131	131
H2O40 / H2O40L					
1st HOUR RATING (GAL/HR)	140 F	103	115	119	119
	115 F	128	147	174	174
CONTINUOUS RATING (GAL/HR)	140 F	67	79	83	83
	115 F	92	111	138	138
H2O50					
1st HOUR RATING (GAL/HR)	140 F	112	124	133	133
	115 F	137	156	192	192
CONTINUOUS RATING (GAL/HR)	140 F	67	79	88	88
	115 F	92	111	147	147
H2O60 / H2O60L					
1st HOUR RATING (GAL/HR)	140 F	121	133	147	147
	115 F	146	165	208	208
CONTINUOUS RATING (GAL/HR)	140 F	67	79	93	93
	115 F	92	111	154	154

Notes:

**176 °F Boiler Supply Water Temperature
 AHRI Rating Conditions - 50 °F Inlet Water
 @ 4.0 GPM FLOW RATE**

**Boiler output over 100,000 BTU does not effect
 tank performance.**

A - LOW WATER CUTOFF

Low Water Cut Off - Heating Only and Combi Boilers

These guidelines are supplied when necessary to install an additional Low Water Cut Off (LWCO), for sensing a low water level condition in a boiler, as required by the Authority Having Jurisdiction.

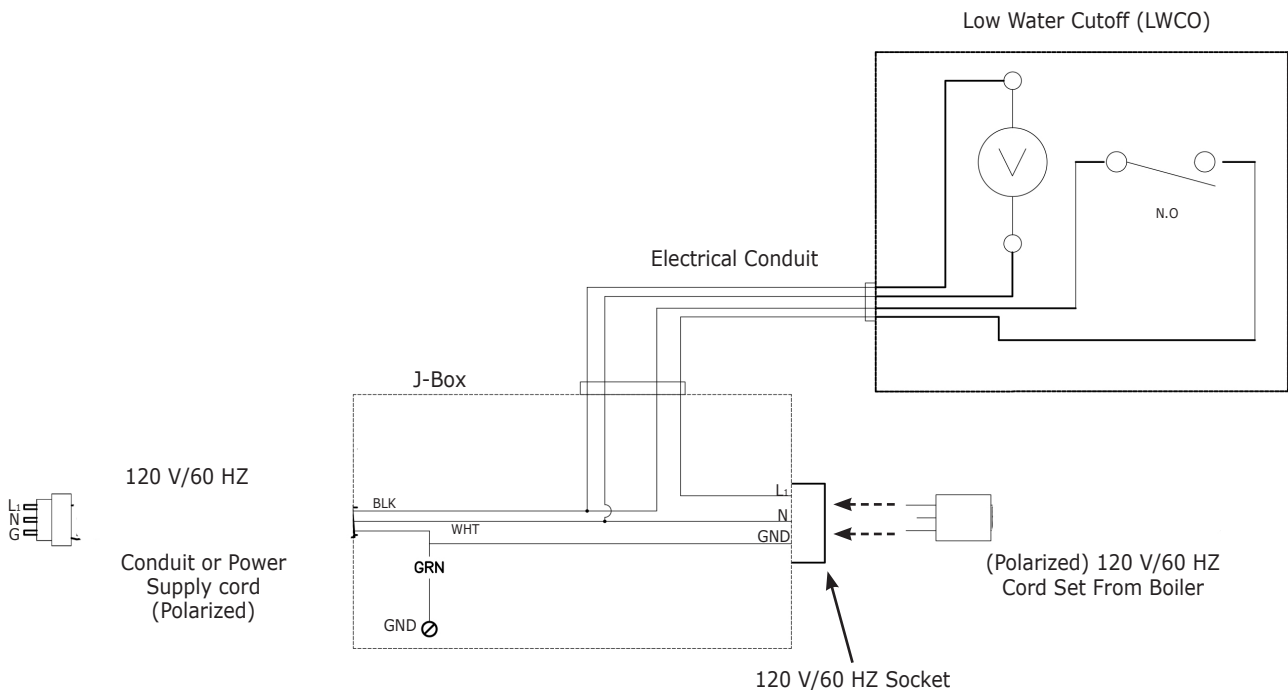
Follow LWCO manufacturer installation instructions for type of LWCO selected in addition to these instructions.

LWCO shall be 120V/60HZ control and dry contacts sized for load being connected. Wire control to boiler. See Figure 1.

Connect LWCO device to the system ground. Ground in accordance with the requirements of the authority having jurisdiction or, in the absence of such requirements, with the National Electrical Code (NEC) or Canadian Electrical Code CEC.

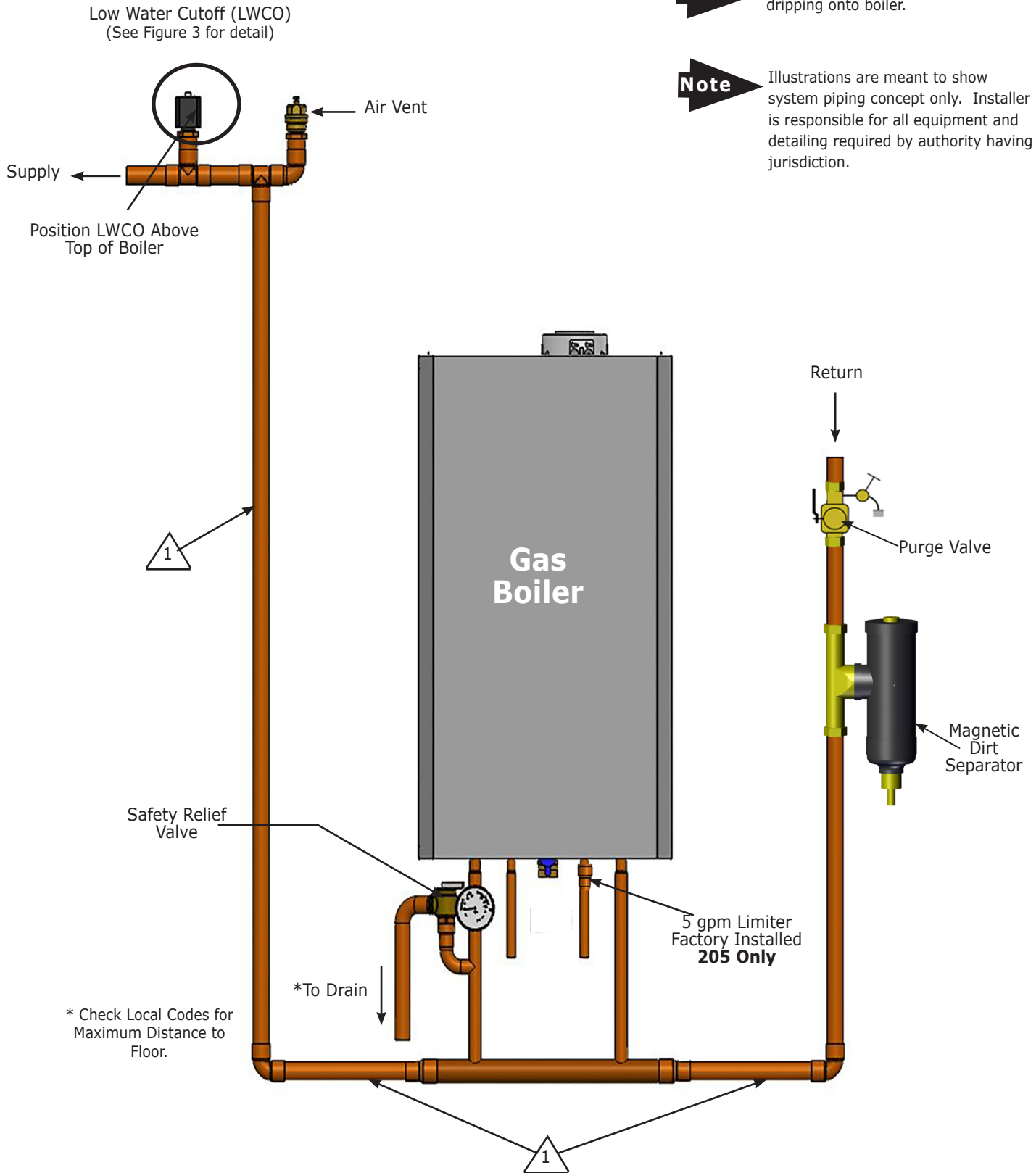
- Locate LWCO sensing device in the supply piping, above the minimum height of boiler. See Figure A-2, Piping Diagram.
- Position control in HORIZONTAL piping to assure proper boiler protection (upright or 90° rotation).
- For proper operation, sensing element of the LWCO control shall be positioned in the tee to sense the main water stream. Maintain minimum 1/4" spacing from pipe walls. Element shall NOT contact the rear, or side walls of the tee. See Figure A-3.
- Install an air vent using a tee to avoid nuisance shutdowns.
- Apply small amount of pipe sealant to threaded connections.
- Arrange piping to prevent water dripping onto boiler.
- DO NOT install water shutoff valve between boiler and LWCO sensing device.

LWCO Wiring Diagram



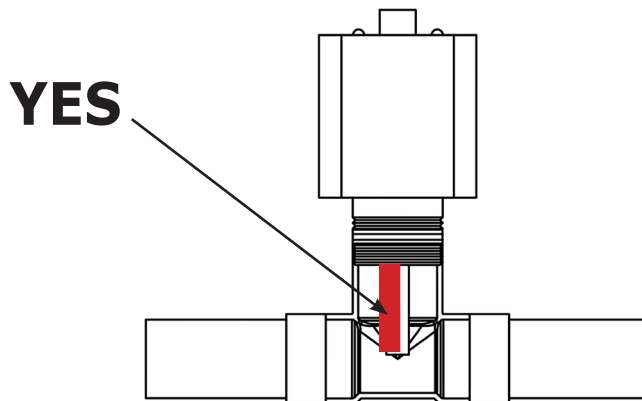
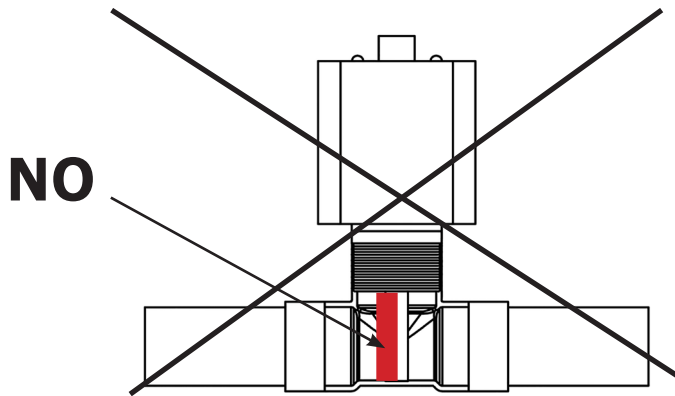
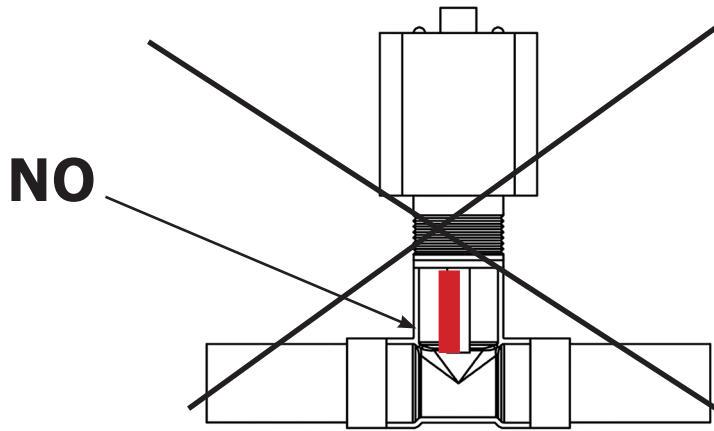
LOW WATER CUTOFF

Piping Diagram - LWCO Location



LOW WATER CUTOFF

Low Water Cutoff - Detail





ECR International Inc. 2201 Dwyer Avenue, Utica, NY 13501
Tel. 800 253 7900
www.ecrinternational.com

All specifications subject to change without notice.
©2018 ECR International, Inc.

IMPORTANT INFORMATION
READ THIS LEAFLET BEFORE COMMISSIONING THE BOILER

IMPORTANT:

**Upon startup of this new boiler please call
ECR International, Inc. Technical Support
for installation assistance and registration.**

**Technical Support and Product Registration
Monday - Friday 8AM to 6PM Eastern time.
1.800.253.7900**

Described below is the procedure to activate the De-Aeration Function/Gas Type Check when power is first supplied to the boiler and the actions required when on a Gas E (LPG) supply.

De-Aeration Function

- When power is supplied to the boiler for the first time **000** will be displayed. If **⏻** is shown, press **⏻R**, for at least 2 seconds **000** will now be displayed.
- Press **iP** & **||||+** together and hold for at least 6 seconds. The “De-Aeration” Function will be activated & “On” showing.
- The boiler pump will run for up to 10 minutes. For 3-way valve models the valve will switch between heating & hot water. This will purge air from the system. The display will show **3 12**.

Gas Type Check

- Once de-aeration is complete on first fire-up the boiler will light and operates for 6 or 7 minutes to automatically check the gas type Gas A (Natural Gas “NG”) or Gas E (Liquefied Petroleum Gas “LPG”). The boiler software check the combustion value against the set value. **000** will be displayed alternating the % value of ignition power and the temperature value °F(°C).
- On a Gas A (Natural Gas) supply the display shows **n G** for at least 10 seconds and the boiler is ready for the normal operation. If the display shows **LPG**, press **⏻R** & **iP** together and hold for at least 4 seconds to exit the function without saving.
- On a Gas E (LPG) supply the display show **LPG**, press **iP** for at least 6 seconds to confirm that this is the intended gas type for the installation.
If the display shows **n G**, press **⏻R** & **iP** together and hold for at least 4 seconds to exit the function without saving then modify **P02=01** as described in the Manual Instructions for the Installer section “PARAMETERS SETTING”.
- While the gas type is being identified, the boiler may be noisy.

IF THE BOILER IS TO BE OPERATED ON GAS E (LP) REPLACE THE EXISTING LABEL WITH THE GAS E LABEL SUPPLIED WITH THIS INSTRUCTION. ASSURE FACTORY SUPPLIED CONVERSION LABEL IS APPLIED TO PRODUCT IF CONVERTING TO LP.

IMPORTANT: Gas type Check

Ensure the maximum heat exchange to the system in Heating or DHW mode (DHW request) in order to avoid the boiler shutoff for overheating.

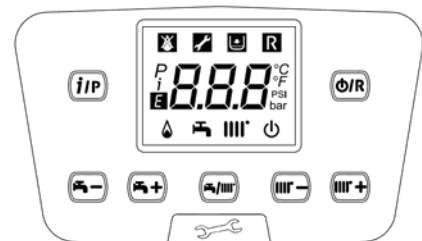
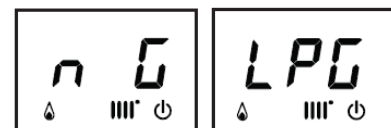
FUNCTION INTERRUPT

If either De-aeration or Gas Check is interrupted by electrical power failure is necessary to reactivate the function by pressing **iP** & **||||+** together for at least 6 seconds. During De-aeration, if the display shows E118 (water low pressure), open the water filling tap and repressurising the system to the correct pressure value. During Gas Type Check, if the display shows E133 (Ignition Failure), press **⏻R** button to Reset then press together **iP** & **||||+** for at least 6 seconds to restart the function. During Gas Type Check, if the boiler switch off for overheating failure is necessary to reactivate the function by pressing **iP** & **||||+** together for at least 6 seconds.

IMPORTANT: The combustion for this appliance has been checked, adjusted and pre-set at the factory for operation on the gas type specified on the appliance data plate.

During the Gas Type Check Function the combustion ratio will increase for a short time while the gas type is established.

The display shows the Gas Type Check



CG_2120

INFORMATIONS IMPORTANTES



LIRE CET IMPRIMÉ AVANT DE METTRE LA CHAUDIÈRE EN MARCHÉ

IMPORTANT : Lors du démarrage de cette nouvelle chaudière veuillez appeler recueil International, Inc. de support technique pour l'assistance à l'installation et l'enregistrement.



Support technique et enregistrement du produit
lundi - vendredi 8h00 à 18h00 heure de l'Est.
1.800.253.7900

Ci-après la procédure d'activation de la Fonction Désaération/Identification Type de Gaz lorsque la chaudière est raccordée pour la première fois à la réseau électrique et les actions à mettre en œuvre en cas d'alimentation avec du gaz propane.

Fonction Désaération

- Lorsque la chaudière est raccordée pour la première fois à la réseau électrique l'afficheur indique **000**. Si  est affiché, appuyer pendant au moins 2 secondes sur la touche  ; l'afficheur montrera alors le symbole **000**.
- Appuyer simultanément sur les touches **iP** et **|||+** pendant au moins 6 secondes. La fonction « Désaération » est alors activée et l'indication « On » apparaît sur l'afficheur.
- La pompe de la chaudière se met en marche pendant environ 10 minutes. Pour les modèles à production instantanée d'eau chaude, la vanne à 3 voies effectuera la commutation entre les fonctions chauffage et eau chaude sanitaire, ainsi que la purge de l'air présent dans l'installation. L'afficheur indique **3 12**.

Identification du type de gaz

- Quand la désaération est terminée la chaudière se mise en marche pendant environ 6-7 minutes pour vérifier automatiquement le type de gaz utilisé **nG** Gaz A (gaz naturel) ou Gaz E **LPG** (gaz liquide). Le logiciel de la chaudière compare la valeur de combustion avec la valeur prédéfinie. L'afficheur montre **000**, en alternance avec la valeur en % de la puissance d'allumage et la valeur de la température °F (°C) de départ du chauffage.
- Si la chaudière est alimentée au Gaz A (gaz naturel), l'afficheur indiquera **n G** pendant environ 10 secondes. La chaudière est donc prête à fonctionner normalement. Si l'afficheur montre **LPG** appuyer simultanément sur les touches  et **iP** pendant au moins 4 secondes pour quitter sans modifier le réglage d'usine.
- Si la chaudière est alimentée au Gaz E **LPG** (gaz liquide), l'afficheur montrera **LPG**. Appuyer pendant au moins 6 secondes sur la touche **iP** pour valider le type de gaz effectivement utilisé. Si l'afficheur indique **n G** car le gaz d'alimentation n'est pas reconnu, appuyer simultanément sur les touches  et **iP** pendant au moins 4 secondes pour quitter la fonction, puis modifier le paramètre **P02=01** comme cela est décrit dans le manuel d'utilisation pour l'installateur dans « CONFIGURATION PARAMÈTRES » de la chaudière.
- Pendant le phase d'identification du type de gaz la chaudière peut être bruyante.

Si la chaudière est exploitée à GAS E (LP) remplacer l'étiquette existante avec le gaz E ÉTIQUETTE FOURNIE AVEC CETTE NOTICE. Assurer la conversion de la configuration usine étiquette est appliquée au produit SI LA CONVERSION DE LP.


IMPORTANT : Identification du type de gaz

Garantir l'échange thermique maximum à l'installation de chauffage ou de production d'ECS afin d'éviter que la chaudière ne s'éteigne suite à un problème de surchauffe.

INTERRUPTION DE LA FONCTION

Si la fonction de désaération ou d'identification du gaz est interrompue par une coupure de l'alimentation électrique, une fois que le courant est rétabli, réactiver la fonction en appuyant simultanément sur les touches **iP** et **|||+** pendant au moins 6 secondes.

Si pendant la Fonction de Désaération l'afficheur signale l'erreur E118 (basse pression du circuit hydraulique), manœuvrer le robinet de remplissage de l'appareil pour rétablir la pression correcte.

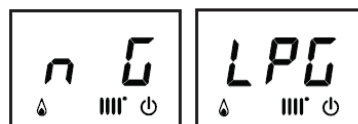
Si la fonction d'identification du gaz est interrompue suite à une erreur (par exemple, E133 absence de gaz), appuyer sur la touche  pour réinitialiser, puis appuyer simultanément sur les touches **iP** et **|||+** (pendant au moins 6 secondes) pour réactiver la fonction.

Si la fonction d'identification du gaz est interrompue suite à un problème de surchauffe, réactiver la fonction en appuyant simultanément sur les touches **iP** et **|||+** pendant au moins 6 secondes.

REMARQUE : la combustion de cet appareil a été contrôlée, étalonnée et prédéfinie en usine pour fonctionner avec du gaz NATUREL.

Pendant la Fonction de Contrôle du Type de Gaz, le rapport de combustion augmentera pour une courte durée afin de permettre l'identification du type de gaz.

L'afficheur montre l'identification du type de gaz.



CG_2120

Required Inspection Schedule To Be Completed By Qualified Service Technician

Inspection Items			Date Completed			
			Year 1	Year 2	Year 3	Year *4
Piping	Near boiler piping	Check boiler and system piping for any sign of leakage, verify pipes are properly supported.				
	Vent	Check condition of all vent pipes and joints. Verify vent piping terminations are free of obstructions and blockages.				
	Safety Relief Valve	Follow manufacturers instructions for maintenance and repair.				
System	Visual	Do full visual inspection of ALL system components.				
	Functional	Test all functions of the system (heat and safety)				
	Temperatures	Verify safe settings on boiler or anti-scald valve.				
Verify programmed temperature settings.						
Electrical	Connections	Check wire connection. Verify connections are tight.				
	Smoke and Co detector	Verify devices are installed and working properly. Change batteries if necessary.				
	Circuit Breakers	Check that circuit breaker is clearly labeled and operates correctly.				
Chamber/ Burner	Combustion Chamber	Check burner and combustion chamber. Clean following directions in maintenance section of IOM. Replace gaskets whenever checking combustion chamber.				
	Spark Electrode	Clean. Set gap according to IOM directions. Clean probe with plumbers cloth to remove oxides.				
	Flame Sensor	Clean probe.				
Condensate	Neutralizer	Check condensate neutralizer - replace if necessary.				
	Condensate pipe/trap	Disconnect condensate pipe. Clean out any dirt or accumulation. Fill with water level of outlet and reinstall. NOTE: verify flow of condensate, make sure hose is properly connected during final inspection.				
Gas	Pressure	Measure incoming pas pressure (3.5 to 14" WC).				
	Pressure drop	Measure drop in pressure on light off (no more than 1" WC).				
	Leaks	Check gas piping. Test for leaks and signs of aging. Make sure all pipes are properly supported.				
Combustion	CO/CO ₂ Levels	Check CO and CO ₂ level in exhaust. See Start-up Procedures for ranges. Record at high and low fire.				
Safety	All Sensors	Check continuity of all sensors. Replace if corroded. Verify all connections through ohms reading.				
Final Inspection	Check List	Verify you have completed entire check list.				
	Homeowner	Review findings and service with Homeowner.				

* Continue inspections beyond 4th year. Maintenance should continue annually for the life of the boiler to ensure safe worry free operation.