



SFH SERIES 5 WATER OIL FIRED CAST IRON BOILER

INSTALLATION, OPERATION & MAINTENANCE MANUAL

Models

SFH-3085W(T)

SFH-4100W(T)

SFH-4125W(T)

SFH-5160W(T)

SFH-6185W(T)

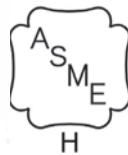

Tested For 75 psi
ASME
Working Pressure



Manufactured by:
ECR International Inc.
2201 Dwyer Avenue, Utica, NY 13501
Tel. 800 253 7900
www.ecrinternational.com
PN 240013073 REV. A [08/31/2020]

1 - TABLE OF CONTENTS

CONTENTS

2 - DIMENSIONS	3
3 - SAFETY INFORMATION.....	4
4 - BEFORE YOU START.....	6
5 - LOCATING THE BOILER.....	7
6 - VENTILATION & COMBUSTION AIR	8
7 - CONNECTING SUPPLY AND RETURN PIPING.....	11
8 - SYSTEM PIPING	17
9 - VENTING SYSTEM INSPECTION & INSTALLATION.....	18
10 - OIL TANK AND PIPING	19
11 - FIELD ASSEMBLY	20
12 - ELECTRICAL WIRING	21
13 - ELECTRICAL WIRING DIAGRAMS	22
14 - OPERATING INSTRUCTIONS	24
15 - BURNER SETTINGS	26
16 - BOILER RATINGS & CAPACITIES	27

For Parts lists see manual 240013074 included with your boiler literature package.

Information and specifications outlined in this manual were in effect at the time of printing of this manual. ECR Internation reserves the right to discontinue, change specifications or system design at any time without notice and without incurring any obligation, whatsoever.

2 - DIMENSIONS

Figure #1 - Dimensional Data

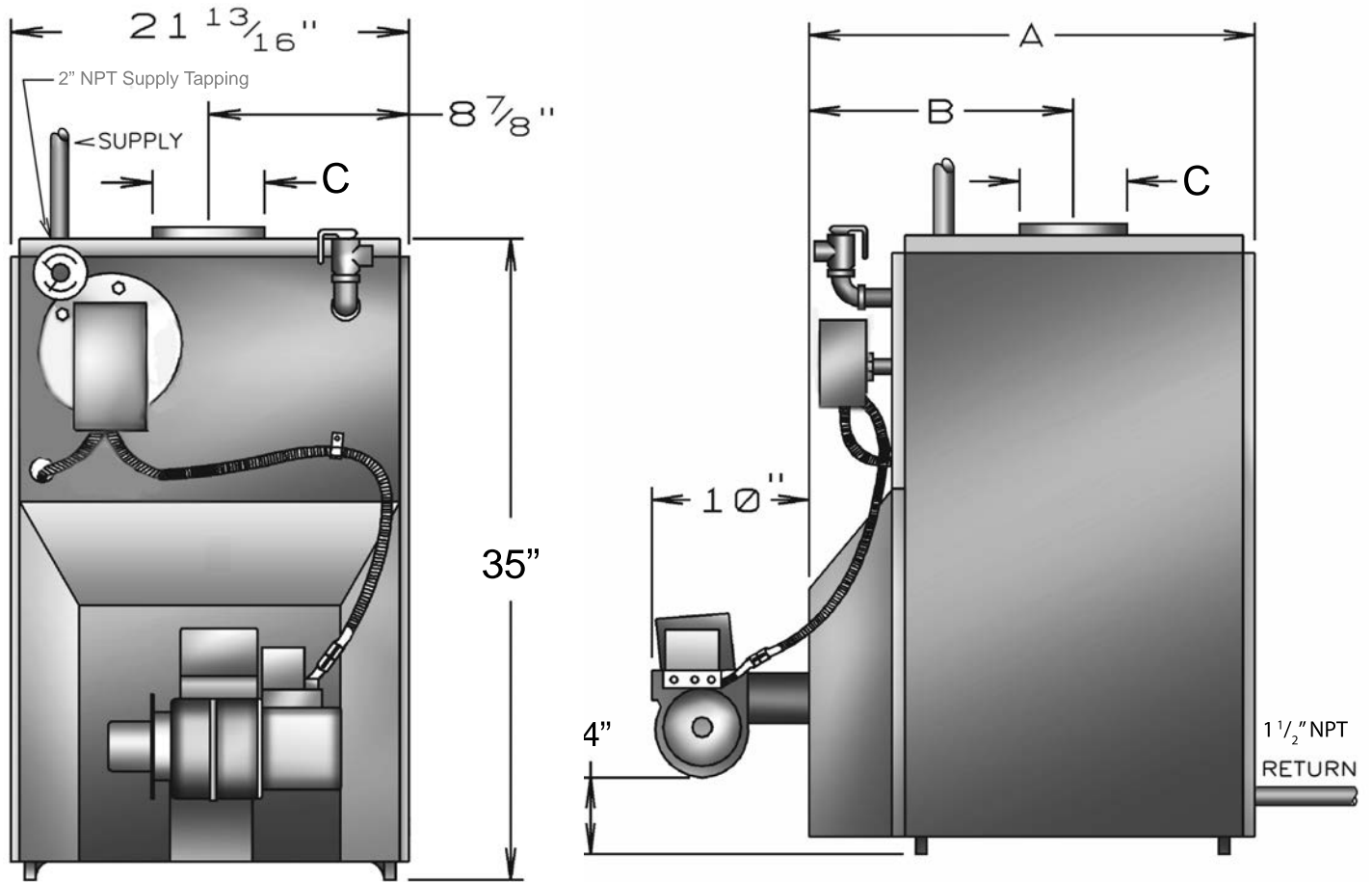

Table - 1

BOILER SECTION	A DEPTH OF FLUSH JACKET	B FRONT OF CASING TO CENTER LINE OF FLUE OUTLET	C DIAMETER OF FLUE OUTLET
3	17 7/8"	11 1/4"	6"
4	21 1/2"	12 5/8"	6"
5	25 1/8"	14 1/4"	7"
6	29 1/4"	15 15/16"	8"

3 - SAFETY INFORMATION

3.1 - General

Boiler installation shall be completed by qualified agency.

WARNING

Fire, explosion, asphyxiation and electrical shock hazard. Improper installation could result in death or serious injury. Read this manual and understand all requirements before beginning installation.

WARNING

Modification, substitution or elimination of factory equipped, supplied or specified components could result in death or serious injury.

WARNING

Installation or venting a boiler or any other oil appliance with improper methods or materials may result in serious injury or death due to fire or to asphyxiation from poisonous gases such as carbon monoxide which is odorless and invisible.

WARNING

Fire, Explosion, Asphyxiation, Electrical shock hazard! Flooding will result in damages such as electrical problems, corrosion, inoperative parts, mold and other unforeseen issues which can occur over time. Any equipment determined by a professional as damaged by a flood, defined as excess of water or other liquid, shall be replaced. Failure to follow these directions will result in a Hazardous Situation.

Become familiar with symbols identifying potential hazards.



This is the safety alert symbol. Symbol alerts you to potential personal injury hazards. Obey all safety messages following this symbol to avoid possible injury or death.

DANGER

Indicates a hazardous situation which, if not avoided, WILL result in death or serious injury

WARNING

Indicates a hazardous situation which, if not avoided, could result in death or serious injury.

CAUTION

Indicates a hazardous situation which, if not avoided, could result in minor or moderate injury.

NOTICE

Used to address practices not related to personal injury.

WARNING

Before filling boiler verify heat exchanger is not hot. Adding water to hot water could result in heat exchanger failure. Failure to follow these instructions could result in death or serious injury.

WARNING

Construction materials of appliance and products of combustion and fuel contain alumina, silica, heavy metals, carbon monoxide, nitrogen oxides, aldehydes and /or other toxic or harmful substances which can cause death or serious injury and which are known to the State of California to cause cancer, birth defects and other reproductive harm. Always use proper safety clothing, respirators and equipment when servicing or working nearby the appliance.

3.2 - Installation shall conform to requirements of authority having jurisdiction or in absence of such requirements to current edition of ANSI/NFPA 31, "Standard for the Installation of Oil Burning Equipment". Such applicable requirements take precedence over general instructions of this manual.

3.3 - Installation shall conform to requirements of authority having jurisdiction or in absence of such requirements to Current Edition of American National Standard ANSI/NFPA 211 "Standard for Chimneys, Fireplaces, Vents and Solid Fuel Burning Appliances" for venting.

3.4 - Where required by authority having jurisdiction, installation shall conform to Standard for Controls and Safety Devices for Automatically Fired Boilers, ANSI/ASME CSD-1.

Additional manual reset low water cutoff and manual reset high limit may be required.

3.5 - Requirements for Commonwealth of Massachusetts:

Boiler installation must conform to Commonwealth of Massachusetts code 248 CMR which includes but is not limited to: Installation by licensed plumber or gas fitter.

FOR YOUR SAFETY READ BEFORE OPERATING



Hot Water Can Scald!

Water heated to temperature for clothes washing, dish washing and other sanitizing needs can scald and cause permanent injury.

Children, elderly, and infirm or physically handicapped persons are more likely to be permanently injured by hot water. Never leave them unattended in bathtub or shower. Never allow small children to use a hot water tap or draw their own bath.

If anyone using hot water in the building fits the above description, or if state laws or local codes require certain water temperatures at hot water taps, you must take special precautions:

- Use lowest possible temperature setting.
- Install some type of tempering device, such as an automatic mixing valve, at hot water tap or water heater. Automatic mixing valve must be selected and installed according to manufacturer's recommendations and instructions.
- Water passing out of drain valves may be extremely hot. To avoid injury:
 - Make sure all connections are tight.
 - Direct water flow away from any person.

Water Temperature Setting	1st Degree Burn Exposure Time For An Adult	2nd and 3rd Degree Burn Exposure Time For An Adult
120° F	1 minute	5 minutes
130° F	5 seconds	30 seconds
140° F	2 seconds	5 seconds
150° F	1 second	1.5 seconds
160° F	Instantaneous	0.5 seconds

Note: Warning for Infants, Children, and Elderly: Great care must be taken when exposing the aforementioned groups to warm or hot water as they can be badly burned in exposure times less than half of the time for an adult.

⚠ WARNING

Combustion chamber insulation in this product contains ceramic fiber material. Ceramic fibers can be converted to cristobalite in very high temperature applications. The International Agency for Research on Cancer (IARC) has concluded, Crystalline silica inhaled in the form of quartz or cristobalite from occupational sources is carcinogenic to humans (Group1). Avoid breathing dust and contact with skin and eyes. Use NIOSH certified dust respirator (N95). This type of respirator is based on the OSHA requirements for cristobalite at the time this document was written. Other types of respirators may be needed depending on the job site conditions. Current NIOSH recommendations can be found on the NIOSH website <https://www.cdc.gov/niosh/topics/silica/>. approved respirators, manufacturers, and phone numbers are also listed on this website. Wear long-sleeved, loose fitting clothing, gloves, and eye protection. Apply enough water to the combustion chamber lining to prevent dust. Wash potentially contaminated clothes separately from other clothing. Rinse clothes washer thoroughly.

NIOSH stated First Aid. Eye: Irrigate immediately. Breathing: Fresh air.

⚠ CAUTION

Laceration, burn hazard. Metal edges and parts may have sharp edges and/or may be hot. Use appropriate personal protection equipment to include safety glasses and gloves when installing or servicing this boiler. Failure to follow these instructions could result in minor or moderate injury.

WARNING

Verify oil burner nozzle is proper size. Over-firing will result in early failure of boiler sections, and result in a potentially dangerous situation. Failure to follow these instructions could result in death or serious injury.

4.1 Installation and Operation

1. Do not operate unit if any control, switch, components or devices have been underwater or subject to water damage.
2. Before servicing, allow boiler to cool. Always shut off any electricity and oil supply to boiler when working on it.
3. Inspect oil line and connections for leaks.
4. Verify oil burner nozzle is proper size. Over-firing will result in early failure of boiler sections, and result in a potentially dangerous situation.
5. Never vent boiler into enclosed space. Always vent to the outside. Never vent to another room or inside a building.
6. Verify adequate air supply for complete combustion.
7. Relief valve automatically lifts open when system pressure exceeds 30 psi. Before installing relief valve read manufacturer's instructions. Pipe relief valve to a safe location. Check with authorities having jurisdiction.
8. Consider system total water volume, temperature, initial fill pressure and arrangement when sizing and installing expansion tank. Improperly installed and sized expansion tank may result in frequent lifting of relief valve or other heating system problems. Follow expansion tank manufacturer guidelines for installation, and sizing.
9. Purge heating system of air and gases is critical for proper circulation and quiet performance. Once the air is purged, for boiler installations using float type vents, air vents should be closed for normal operation. If air is heard or noticed by loss of heat, purge system and open vents for short period of time.

4.2 Prior To Installing The Boiler

- Verify you have selected right size boiler with proper capacity. AHRI rating of boiler selected should be greater than or equal to calculated peak heating load (heat loss) for building or area(s) served by boiler and associated hot water heating systems. Use heat loss calculations based on approved methods. See Table 6, page 27.
- Boiler must be supplied with proper oil supply and oil piping, sufficient fresh combustion air, and suitable electrical supply.
- Connect boiler to suitable venting and piping systems adequate to distribute heating load.
- Installation is not complete unless pressure relief valve is installed at 3/4" tapping located at front of unit.
- Thermostat must be properly located and installed
- Failure to pipe boiler correctly may result in excessive noise or other related problems.

4.3 Existing Water System Evaluation

A good system will prevent oxygen contamination of boiler water.

1. Causes of oxygen contamination may be:
 - A. Addition of excessive make up water as a result of leaks.
 - B. Absorption through open tanks and fittings.
 - C. Oxygen permeable materials in the distribution system.
2. To insure long product life, oxygen sources must be eliminated.

Take the following measures:

 - A. Repair system leaks.
 - B. Eliminate open tanks from the system.
 - C. Eliminate and/or repair fittings which allow oxygen absorption.
 - D. Use non-permeable materials in the heating system.

WARNING

Fire hazard. Do not install on carpeting, wood, or vinyl flooring. Failure to follow these instructions could result in death or serious injury.

NOTICE

Clearance for access should exceed fire protection clearance.

1. Boiler is listed for installation on non-combustible flooring only.
2. Locate boiler in front of final position before removing crate.
3. Locate unit so vent pipe connection to chimney will be short and direct.
4. When installed in utility room, door should be wide enough to allow largest boiler part to enter, or to permit replacement of another appliance such as water heater
5. For basement installation, provide solid elevated base, such as concrete, if floor is not level, or if water may be encountered on floor around boiler.
6. Minimum clearances to combustible construction are:
 - TOP 24 IN.
 - FRONT 24 IN.
 - FLUE CONNECTOR 9 IN.
 - REAR 6 IN.
 - LEFT SIDE 6 IN.
 - RIGHT SIDE.....24 IN.
 - FLOOR.....NON-COMBUSTIBLE
7. Fresh air for combustion and ventilation must be available at boiler. Ventilating and combustion air must enter boiler room without restrictions.
8. Keep boiler area clear and free from combustible materials, gasoline and other flammable vapors and liquids.
9. DO NOT obstruct air openings to the boiler room.

⚠ WARNING

Asphyxiation, fire hazard. Do not obstruct air openings to combustion area. Follow instructions below, to maintain adequate combustion air.

**Table 2 - COMBUSTION AIR REQUIREMENTS
(MINIMUM OPENING IN SQUARE INCHES)**

INPUT (Mbh)	*UNCONFINED AREA		**CONFINED AREA	
	OUTSIDE COMBUSTION AIR	INSIDE COMBUSTION AIR	OUTSIDE COMBUSTION AIR	
	1 IN ² /5000Btu/HR (PARAGRAPH 4)	1 IN ² /1000 Btu/HR (MIN 100IN ²) (Figure 1)	1 IN ² /4000 Btu/HR (Figures 2&3)	1 IN ² /2000 Btu/HR (Figure 4)
119	24	119	30	60
140	28	140	35	70
175	35	175	44	88
203	41	203	51	102
224	45	224	56	112
245	49	245	62	123
259	52	259	65	130
294	59	297	74	147

* Unconfined area: A space whose volume is not less than 50 cubic feet per 1000 Btu per hour of all appliances installed in that space (cubic feet of space = height x width x length).

** Confined area: A space whose volume is less than 50 cubic feet per 1000 Btu per hour of all appliances installed in that space (cubic feet of space = height x width x length).

1. Provide combustion air and ventilation air in accordance with the section "Air for Combustion and Ventilation," of NFPA 31: *Standard for the Installation of Oil-Burning Equipment*.
2. Boiler room ventilation must be adequate enough to provide sufficient air to properly support combustion. See Table 2.
3. When boiler is located in an unconfined space in a building of conventional construction frame, masonry or metal, infiltration normally is adequate to provide air for combustion and ventilation. However, in any building which has been altered to conserve energy or to minimize infiltration, boiler area should be considered as a CONFINED SPACE.
4. When a boiler is installed in an unconfined space, in a building of unusually tight construction, air for combustion and room ventilation must be obtained from outdoors or from spaces freely communicating with the outdoors. A permanent opening or openings having a total free area of not less than 1 square inch per 5,000 Btu per hour of total input rating of all appliances shall be provided. Ducts may be used to convey make-up air from the outdoors and shall have the same cross-sectional area of the openings to which they are connected.

6 - VENTILATION & COMBUSTION AIR

5. When air for combustion and room ventilation is from inside buildings, confined space shall be provided with two permanent openings, one starting 12 inches from the top and one 12 inches from the bottom of the enclosed space. Each opening shall have a minimum free area of 1 square inch per one thousand (1,000) Btu per hour of the total input rating of all appliances in the enclosed space, but must not be less than one hundred (100) square inches. These openings must freely communicate with the interior areas having adequate infiltration from the outside. See Figure #2.
6. When the boiler is installed in a confined space and all air is provided from the outdoors, the confined space shall be provided with two permanent openings, one commencing within 12 inches from the top and one commencing 12 inches from the bottom of the enclosure. The openings shall communicate directly, or by ducts, with the outdoors or spaces (crawl or attic) that freely communicate with the outdoors. One of the following methods must be used to provide adequate air for ventilation and combustion.
 - A. When directly communicating with the outdoors, each opening shall have a minimum free area of 1 square inch per 4,000 Btu per hour of total input rating of all equipment in the enclosure. See Figure #3.
 - B. When communicating with the outdoors by means of vertical ducts, each opening shall have a minimum free area 1 square inch per 4,000 Btu per hour of total input rating of all appliances in the enclosed space. See Figure #4.
 - C. If horizontal ducts are used, each opening shall have a minimum free area 1 square inch per 2,000 Btu per hour total input rating of all appliances in the enclosed space. See Figure #5.
 - D. When ducts are used, they shall be of the same cross sectional area as the free area of the area of the openings to which they connect. The minimum dimension of rectangular air ducts shall not be less than 3 inches.
7. In calculating free area using louvers, grills or screens for the above, consideration shall be given to their blocking effect. Screens used shall not be smaller than $\frac{1}{4}$ inch mesh. If the free area through a design of louver or grill is known, it should be used in calculating the size opening required to provide the free area specified. If the design and free area is not known, it may be assumed that wood louvers will have 20-25% free area and metal louvers and grills will have 60-75% free area. Louvers and grills shall be fixed in the open position or interlocked with the boiler so that they are opened automatically during boiler operation. Refer to *Combustion Air Requirements* chart on page 8 for combustion air minimum opening requirements.

Figure #2

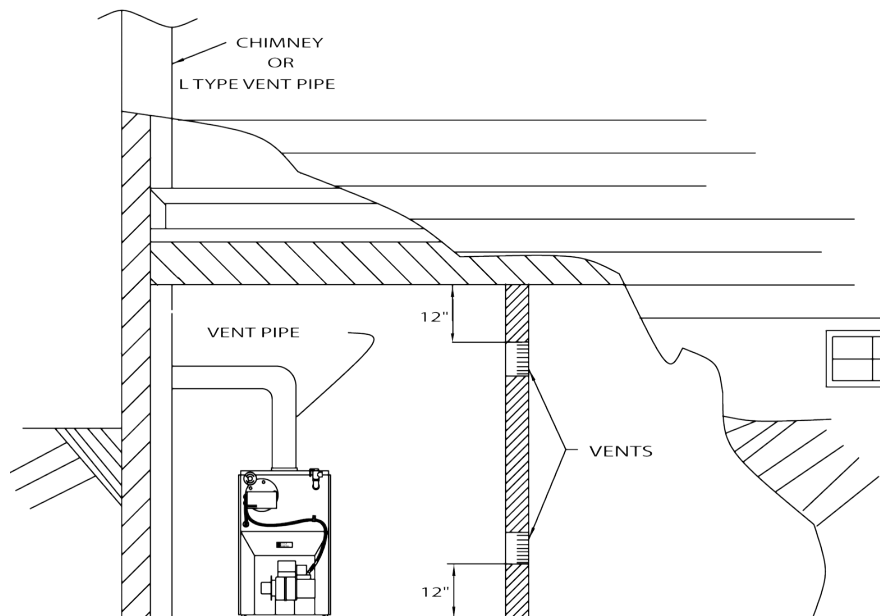

Figure #3

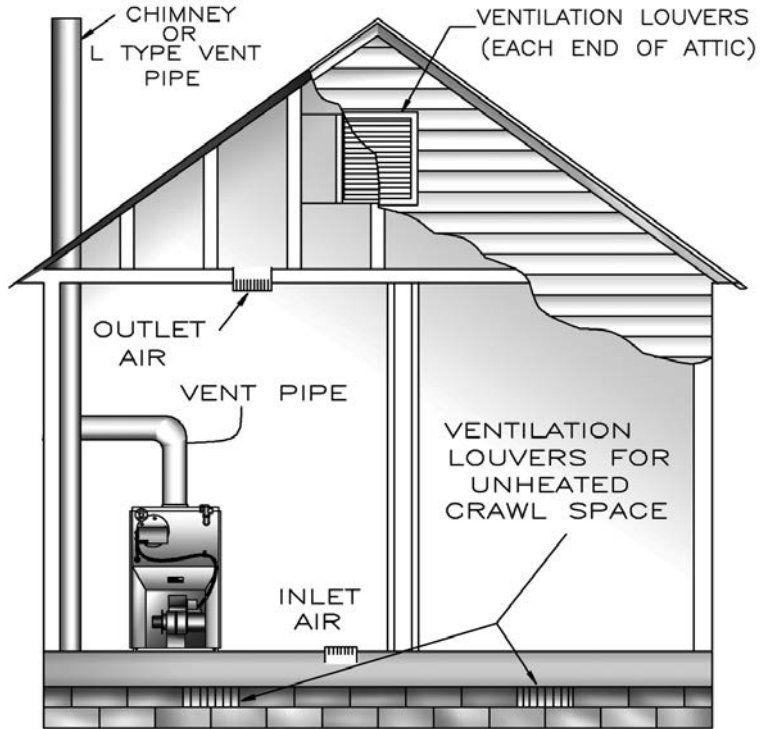

Figure #4

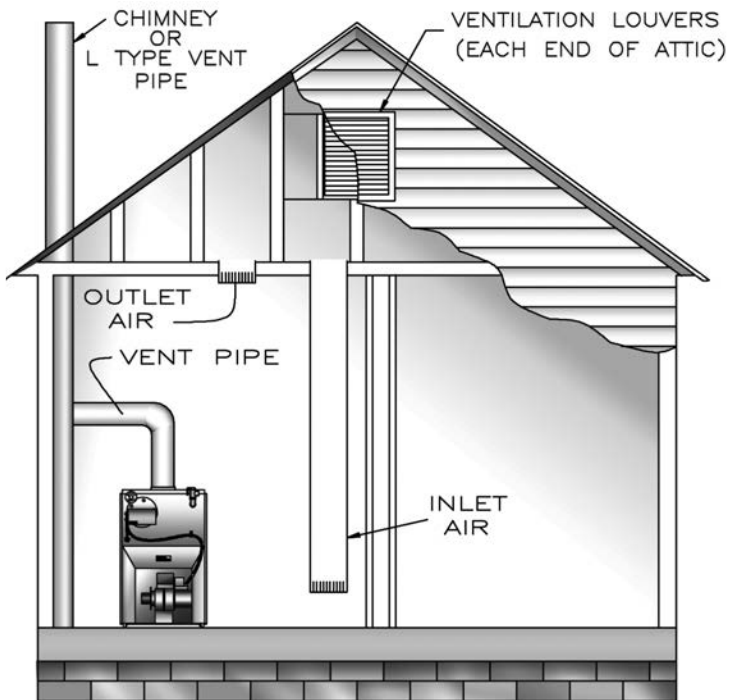
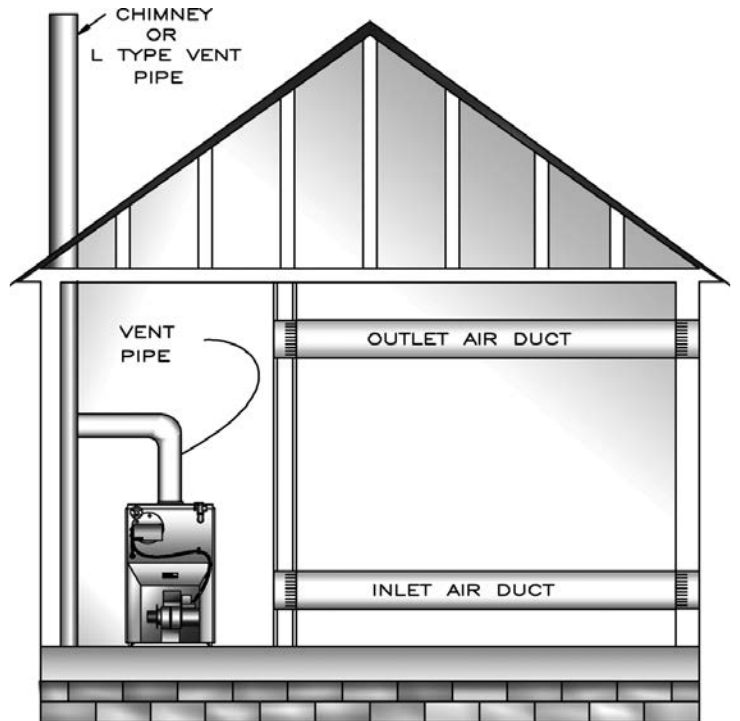

Figure #5



7 - CONNECTING SUPPLY AND RETURN PIPING

1. Connect supply and return piping. See Figure #6. When boiler is used in connection with refrigerated systems:
 - A. Chilled medium *must be in parallel* with boiler.
 - B. Use appropriate valves to prevent chilled medium from entering heating boiler.
2. During heating cycle open valves A and B, close valves C and D.
3. During cooling cycle open valves C and D, close valves A and B.
 - A. Maintain minimum clearance of one inch to hot water pipes.
4. Hot water boilers installed above radiation level must be provided with low water device either as part of boiler or at time of boiler installation.
5. When boiler is connected to heating system utilizing multiple zoned circulators, each circulator must be supplied with flow control valve to prevent gravity circulation.
 - * *Reduced pressure back flow preventer shall be used under provisions required by the Environmental Protection Agency, (EPA).*
6. Bypass piping is an option which gives ability to adjust supply boiler water temperature to fit system or condition of installation. Although, this method of piping is not typically required for baseboard heating systems.

In air handling units where they may be exposed to refrigerated air circulation, boiler piping system **MUST** be supplied with flow control valves or other automatic means to prevent gravity circulation of boiler water during cooling cycle.

Figure #6 Typical Piping Configuration

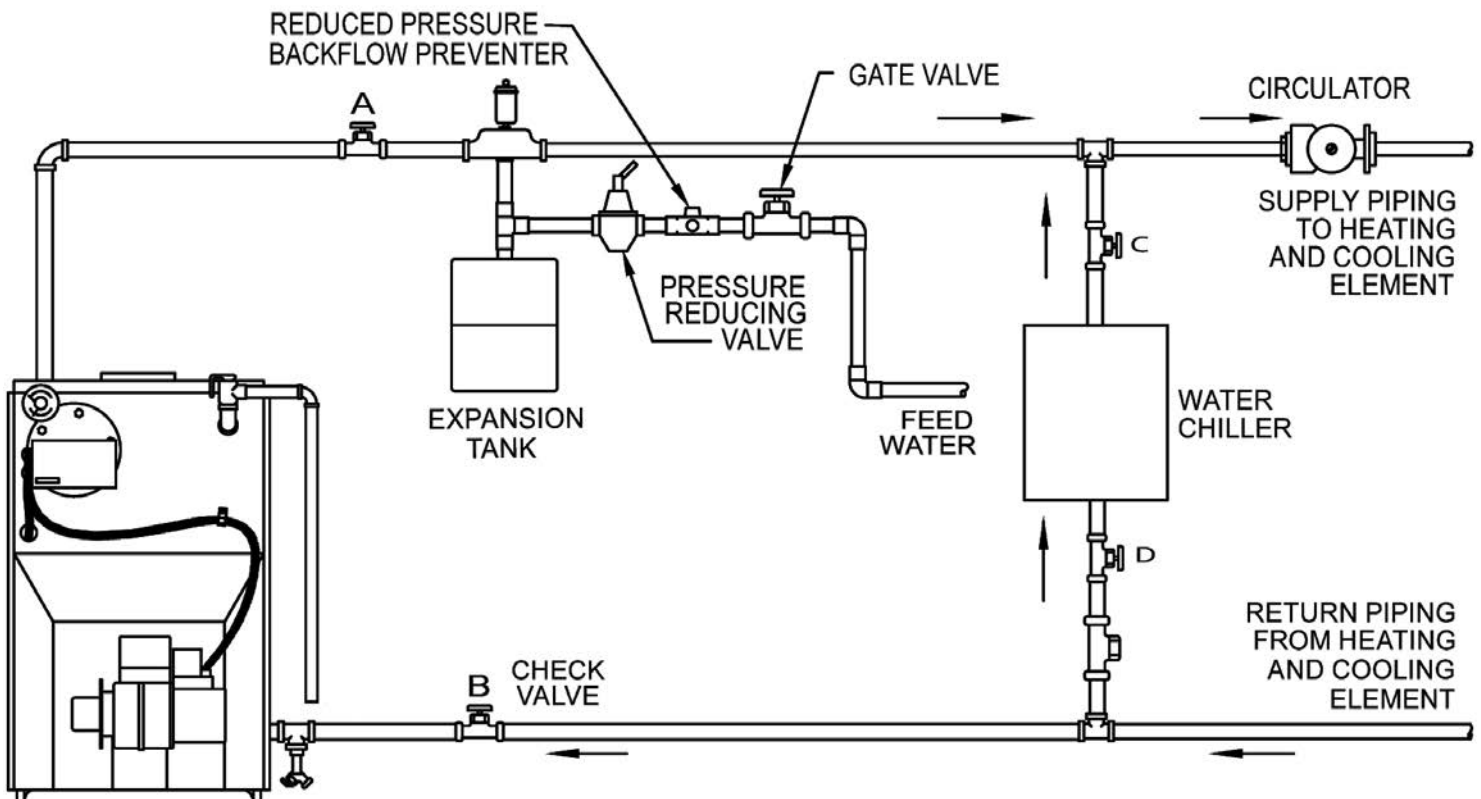

7 - CONNECTING SUPPLY AND RETURN PIPING

- A. This method is used to protect boilers from condensate forming due to low temperature return water. Generally noticed in large converted gravity systems or other large water volume systems. See Figure #7.
- B. These methods are used to protect systems using radiant panels and material they are encased in from high temperature supply water from boiler and protect boiler from condensation. See Figures #8 and #9.
- C. This method is used to protect boilers from condensate forming as well as protecting heating system from high water temperature. See Figure #9.

Note: When using bypass piping, adjust valves A and B until desired system temperature is obtained.

- 7. Bypass loop piping must be same size piping for supply and return.

Figure #7 Bypass Piping

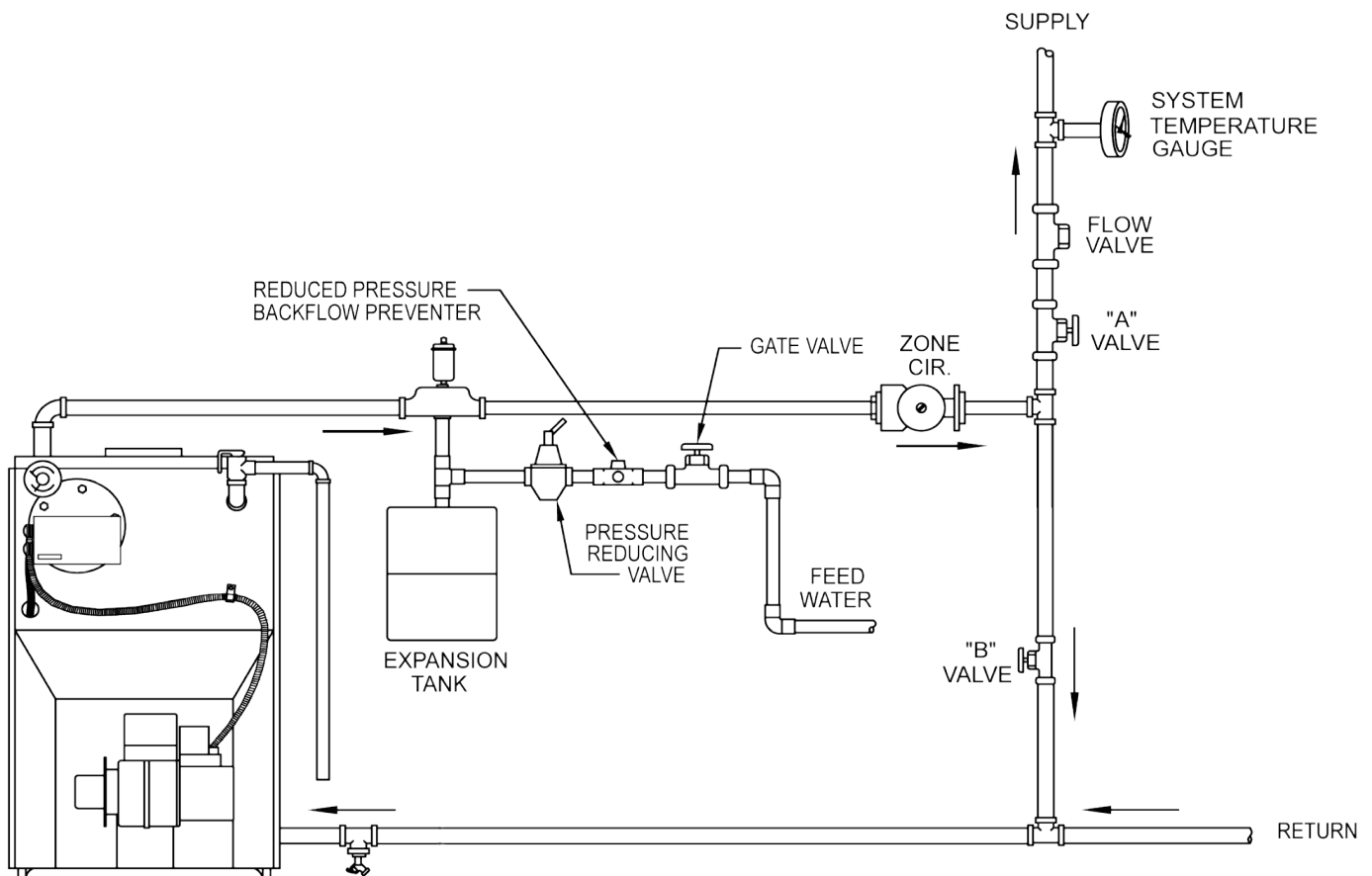

Figure #8 - Mixing Valve Piping

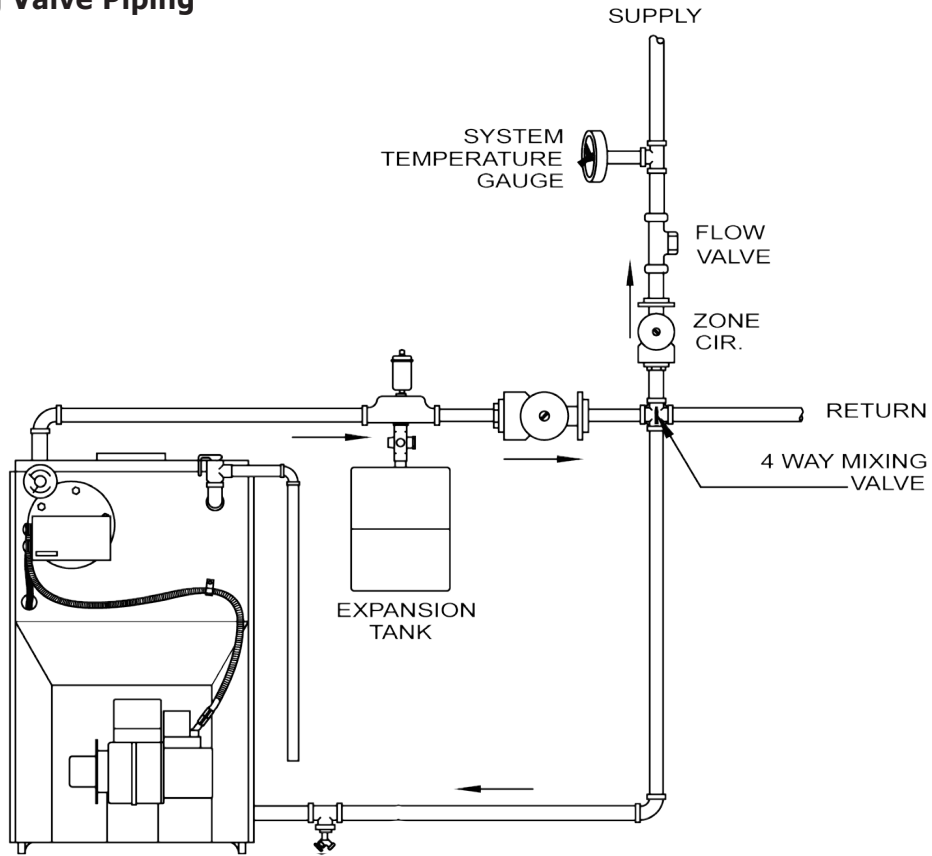

Figure #9 - Primary Secondary Piping With Bypass

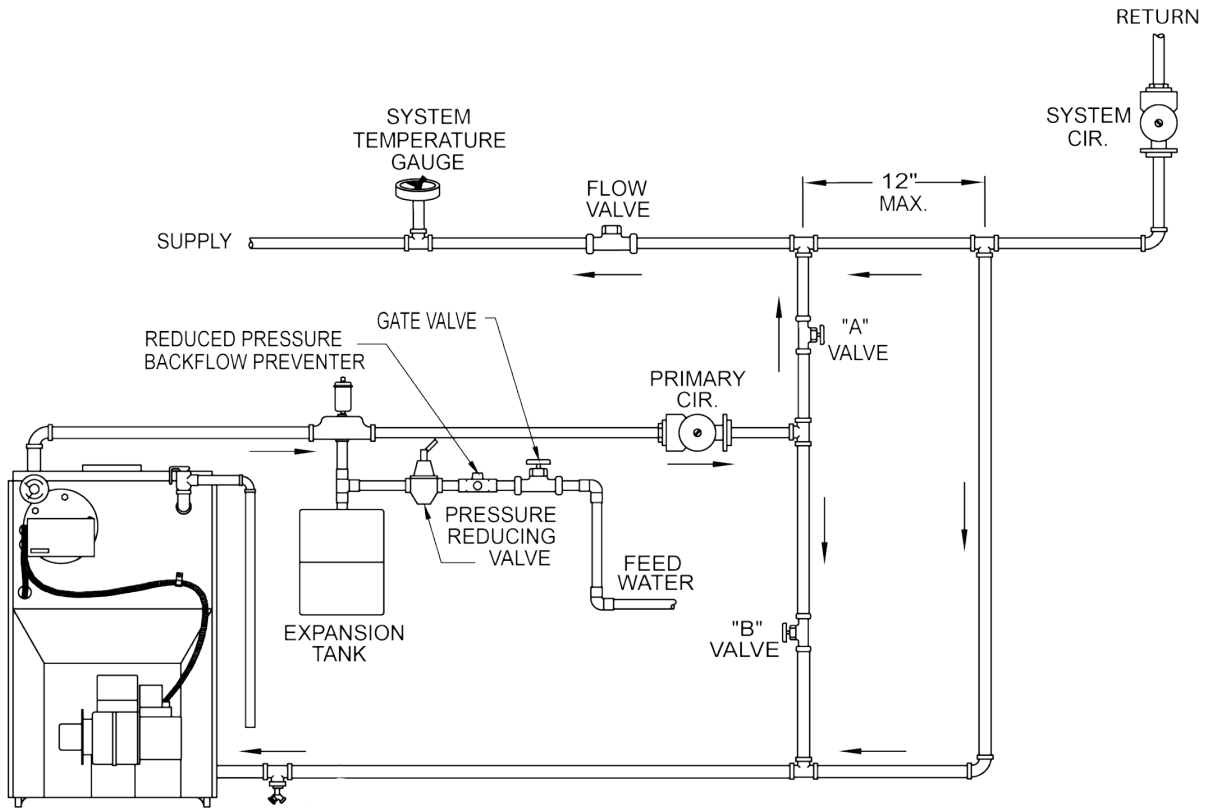

Figure #10 - Indirect Water Heater Piping with Circulator

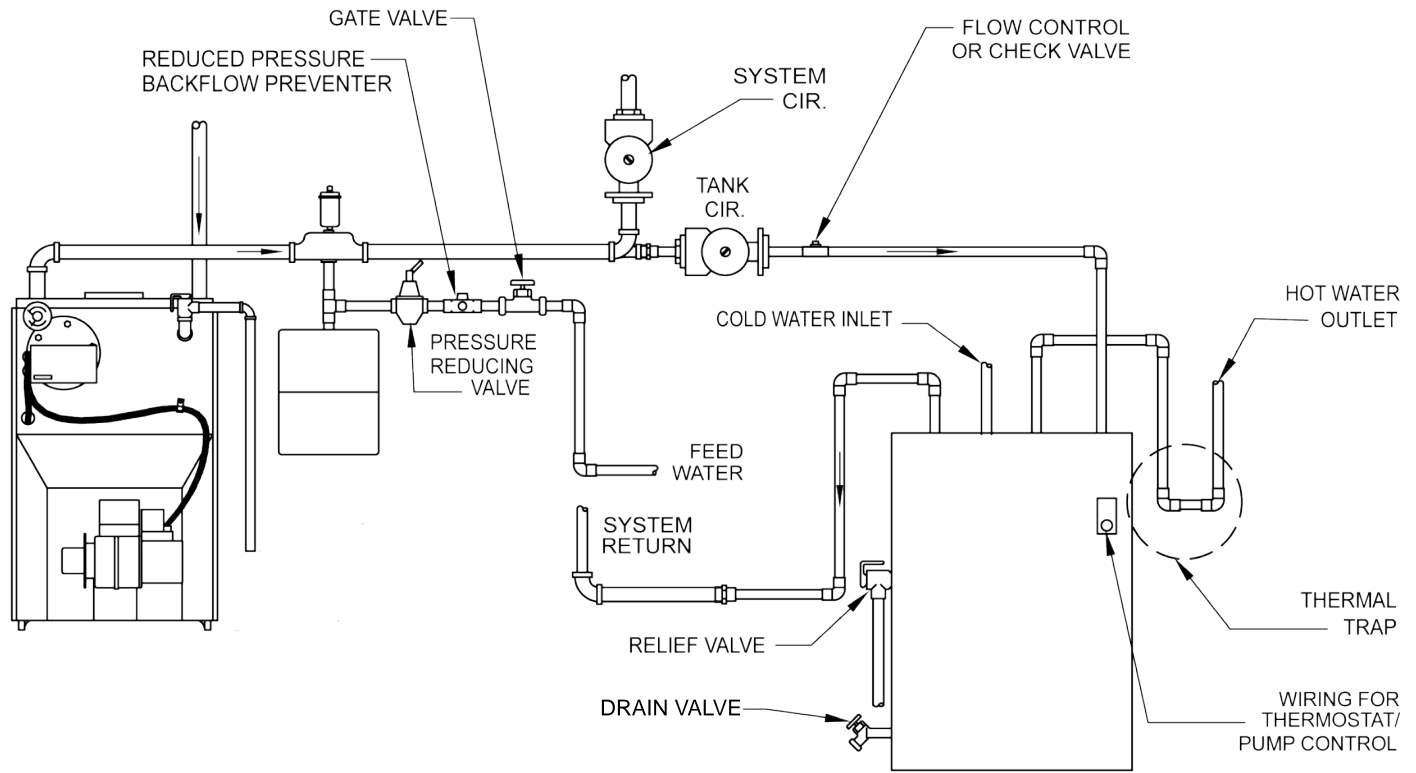

Figure #11 - Indirect Water Heater Piping with Zone Valve

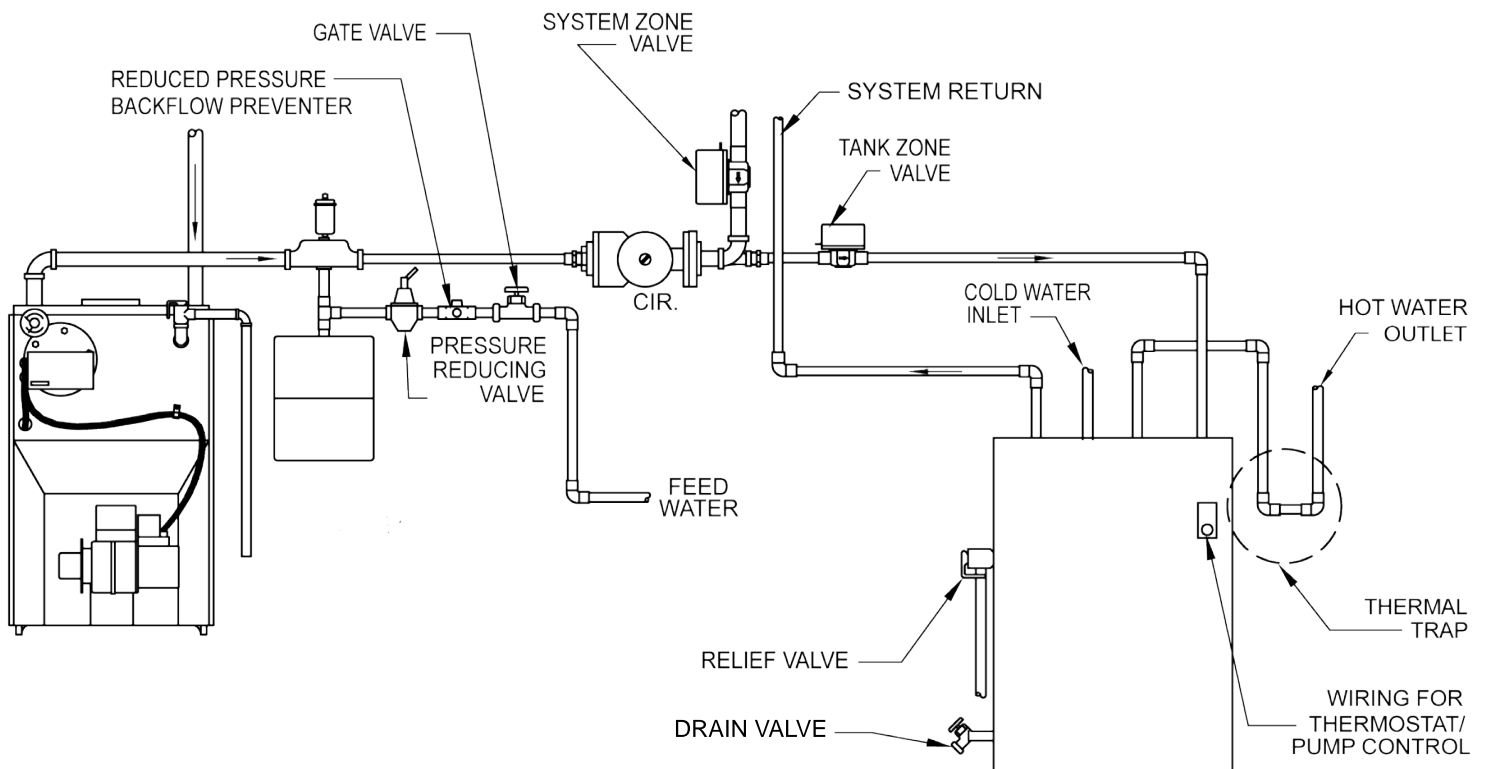
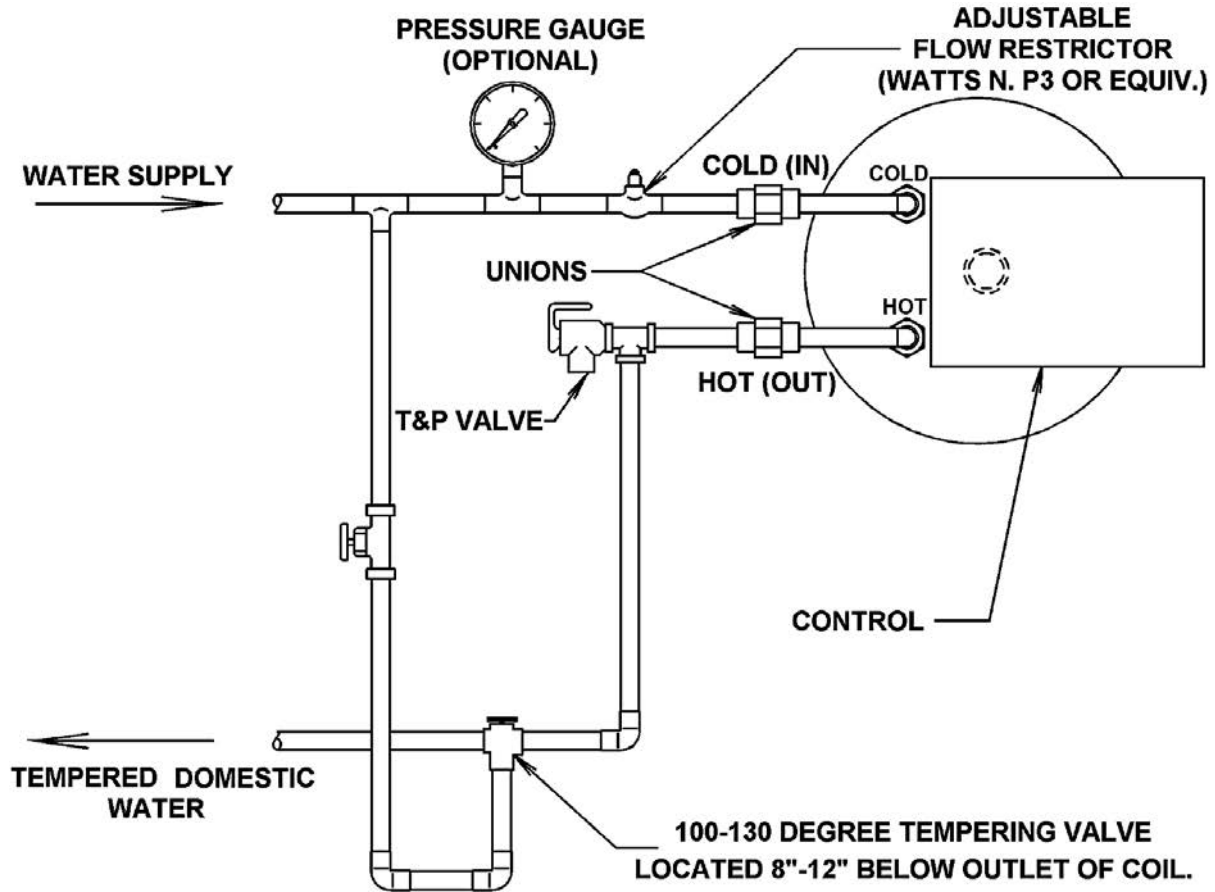

Figure #12 - Recommended Piping For Boilers Equipped With T3 Or T4 Tankless Heater



⚠ DANGER

Water temperatures exceeding 125°F will cause severe burns instantly or death by scalding.

8. Typical indirect water heater installation using circulators is shown in Figure #10.
9. Typical indirect water heater installation using zone valves is shown in Figure #11.
10. Install automatic mixing valve on outlet of domestic coil. Installation must comply with valve manufacturer's recommendations, and instructions.
 - Do not remove bolts or limit at time of installation.
 - Pipe in accordance with boiler's Installation, Operation and Maintenance Manual.
 - Due to varying water conditions, adjustable flow restrictor must be installed in cold water inlet of this coil.

7 - CONNECTING SUPPLY AND RETURN PIPING

OPTIONS UTILIZING 3/4" TAPPING

Figure #13 - Optional Location For Air Vent

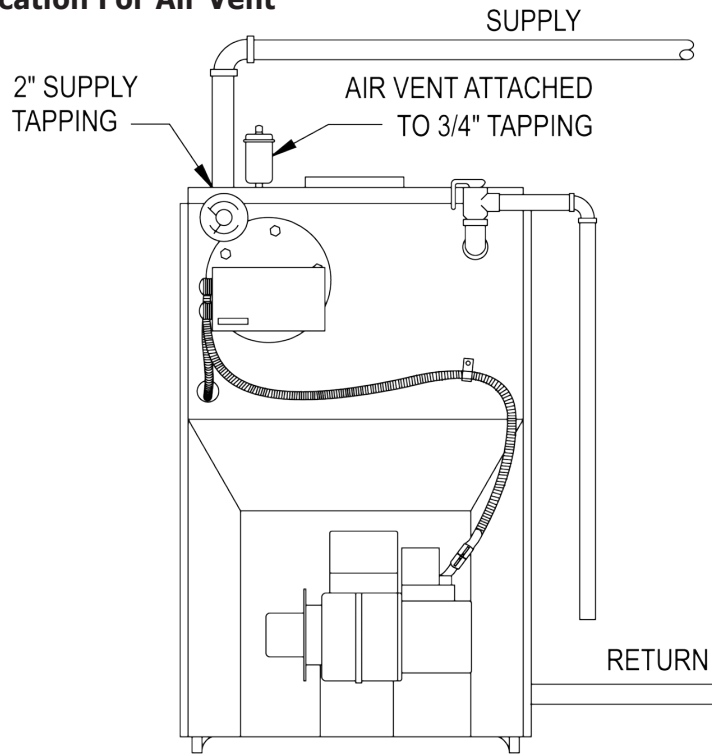
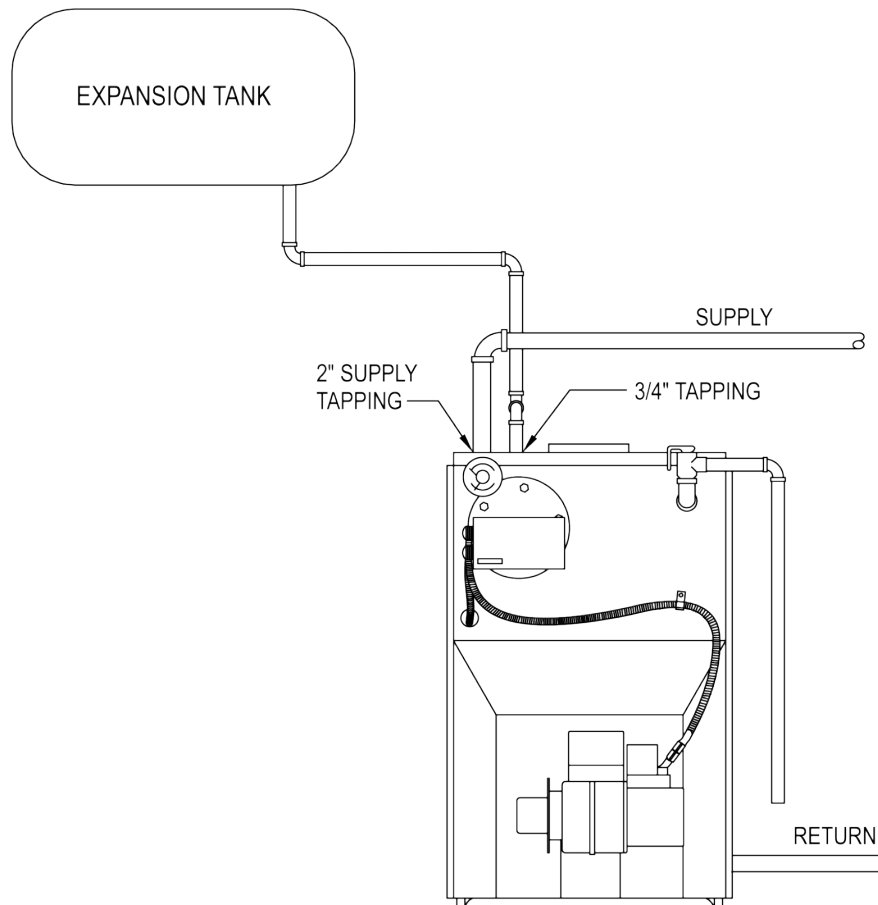

Figure #14 - Optional Location For Expansion Tank (Non-Diaphragm Type)



8 - SYSTEM PIPING

⚠ WARNING

Burn and scald hazard. Safety relief valve could discharge steam or hot water during operation. Install discharge piping per these instructions.

1. Install safety relief valve using pipe fittings provided with boiler.
2. Install safety relief valve with spindle in vertical position.
3. Do not install shutoff valve between boiler and safety relief valve.
4. DO NOT pipe in area where freezing can occur. DO NOT install shutoff valves, plugs or caps.
5. Install discharge piping from safety relief valve. See Figure #15.
 - Use $\frac{3}{4}$ " or larger pipe.
 - Use pipe suitable for temperatures of 375°F (191°C) or greater.
 - Individual boiler discharge piping shall be independent of other discharge piping.
 - Size and arrange discharge piping to avoid reducing safety relief valve relieving capacity below minimum relief valve capacity stated on rating plate.
 - Run pipe as short and straight as possible to location protecting user from scalding and properly drain piping.
 - Install union, if used, close to safety relief valve outlet.
 - Install elbow(s), if used, close to safety relief valve outlet and downstream of union (if used).
 - Terminate discharge pipe with plain end (not threaded).

Figure #15 - Discharge Piping From Safety Relief Valve

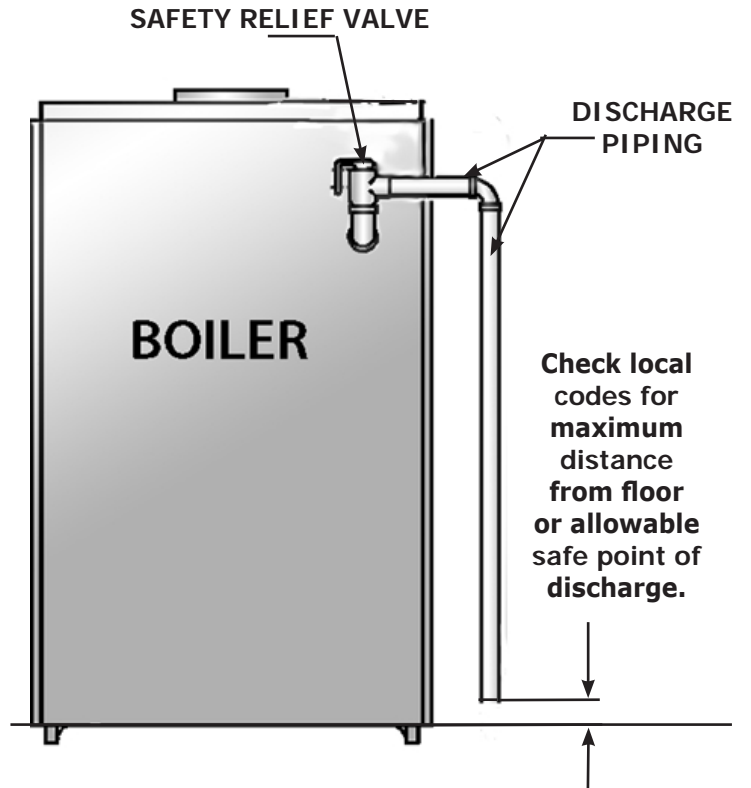

9 - VENTING SYSTEM INSPECTION & INSTALLATION

Chimney construction shall conform to the requirements of authority having jurisdiction or in absence of such requirements *NFPA 211, Standard for Chimneys, Fireplaces, Vents and Solid-Fuel Burning Appliances.*

Venting system installation shall conform to the requirements of the authority having jurisdiction or in the absence of such requirements, to *NFPA 31 - Standard for the Installation of Oil Burning Equipment.*

1. INSPECT CHIMNEY

- Boiler shall be installed into chimney which has masonry or metallic chimney liner.
- An unlined chimney will have leaks that will cause poor chimney performance (NO DRAFT), and could result in positive pressure in combustion chamber.
- Horizontal portions of venting system should not exceed 10 feet in length. Horizontal lengths over 10 feet will have negative effect on chimney performance.
- Chimney should extend at least 2 feet above any portion of building within 10 feet. See Figure #16. It should produce negative draft of .06 to .08 inches of water column, (W.C.), as measured with draft gauge between boiler and barometric draft control while maintaining .02 inch W.C. negative draft in combustion chamber.
- Inadequate draft will cause improper combustion, resulting in dirty flue ways and high fuel bills.

2. CONNECT FLUE PIPE

- Connect flue pipe same size as boiler outlet to chimney, sloping upward continuously toward chimney approximately $\frac{1}{4}$ " per foot. Bolt or screw joints together to avoid sag.
- If oil fired water heater is vented into same flue as boiler, provide separate hole into chimney whenever possible. When not possible, use "Y" connection in flue pipe, using separate draft regulator for each unit.
- When chimney will not provide adequate draft to handle input from water heater and boiler simultaneously, wire units so that only one will operate at a time, favoring water heater.

Figure #16

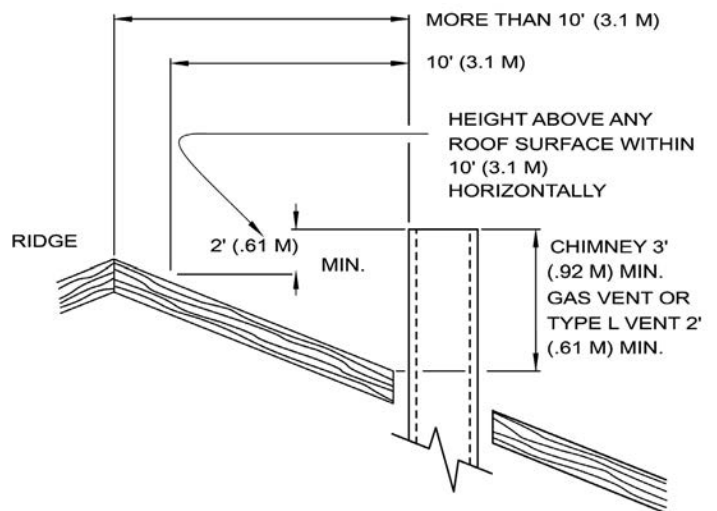

10 - OIL TANK AND PIPING

1. Installation of oil tank and piping shall conform to requirements of authority having jurisdiction or in absence of such requirements to *NFPA 31 - Standard for the Installation of Oil-Burning Equipment*.
 2. Installation of oil storage tank, vent, fill pipe and caps shall conform to requirements of authority having jurisdiction.
 - In no case should vent pipe be smaller than 1¼" I.P.S.
 - Fill pipe should not be less than 2" I.P.S.
 - Suction line from tank to burner should be one continuous piece of tubing to prevent air entering line
 - Suction line, must be ¾" O.D. copper tubing for runs of 50 feet or less, and ½" O.D. for longer runs.
 - Use oil return line, same size as the suction line, on installations where bottom of tank is below fuel unit of burner.
 - Bury oil lines or protect from mechanical injury.
 - Flare fittings on all oil lines are required. Compression fittings on suction line often allow air to be drawn into fuel pump, making it difficult to maintain oil pressure at nozzle.
 - Do not run overhead fuel lines from tank to oil burner.
- Follow instructions, attached to fuel pump, for fuel pump and by-pass connections.
 - Install two stage fuel unit if tank is more than 20' from boiler in place of single stage pump supplied as standard equipment with burner. Verify rotation and speed are identical and pump is suitable for burner horsepower rating.
 - Install oil line filter and shut-off valve in suction line.
 - Install Shut-off valves in both suction and return lines at burner for convenience in servicing burner.
 - Allow extra tubing at burner so burner may be removed from boiler for cleaning without disconnecting tubing. See Figures #17 and #18.
 - Use flexible oil lines so burner swing door can be opened without disconnecting oil supply piping.

Figure #17 - Typical Installation Single Pipe Oil System

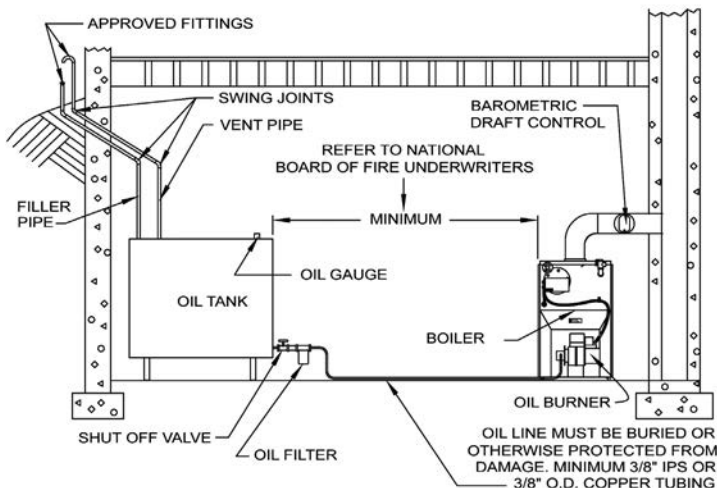
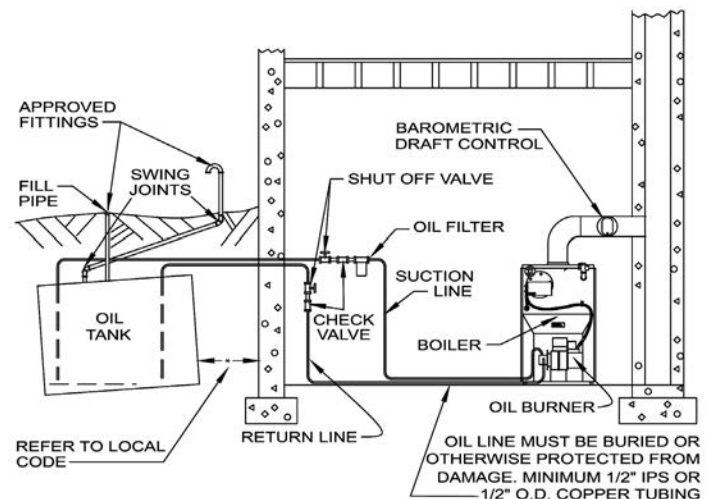

Figure #18 - Typical Installation Two Pipe Oil System



1. Install oil burner. Follow burner manufacturer specific instructions for installation.
 - Check oil nozzle in burner for size, angle and type, inspect electrode settings, check head setting, check air band and air shutter settings. See "Oil Burner, Nozzle, & Air Settings" .
 - DO NOT install burner without gasket. Place oil burner gasket on face of burner swing door with 4 burner flange bolts installed part way.
 - Align round part of key hole slots of burner flange with burner door bolts. Turn burner to lock in place.
 - Tighten all 4 cap screws using diagonal sequence.
 - Plug burner power cord into burner harness.
 - Attach flexible oil hose included in parts box.
 - Connect burner quick connect to corresponding High Limit Control harness. See Figure #22.
2. Follow circulator manufacturer specific instructions included with circulator if appropriate.

⚠ WARNING

Electrical shock hazard. Turn OFF electrical power supply at service panel before making electrical connections. Failure to do so could result in death or serious injury.

12.1 Electrical wiring shall conform to requirements of authority having jurisdiction or in absence of such requirements ANSI/NFPA No. 70 National Electrical Code.

Electrically bond boiler to ground in accordance with requirements of authority having jurisdiction. Refer to: USA- National Electrical Code, ANSI/NFPA 70.

A. Electrical Service Field Wiring

120 volt power supply field wiring connects to limit control. Provide appropriate overcurrent protection and service disconnect switch.

B. Thermostat Installation

1. Thermostat should be installed on inside wall about four feet above the floor.
2. **NEVER** install thermostat on outside wall.
3. Do not install thermostat where it will be affected by:
 - Drafts
 - Hot or cold pipes
 - Sun light
 - Lighting fixtures
 - Television sets
 - Fireplace or chimney
4. Check thermostat operation by raising and lowering thermostat as required to start and stop burner.
5. Instructions for final adjustment of thermostat are packaged with thermostat (adjusting heating anticipator, calibration, ect.).

C. Hydrostat 3250 Hi-Limit/LWCO Control

See Figure #19

Combined High Limit, Low Limit and Low Water Cutoff.

- Well mounted to front of boiler.
- Temperature probe installed in well is attached to 4-pin plug inside limit control box.
- If connecting boiler to indirect water heating system change zone switch from Z to I on Hydrostat controller.
- Adjust High Limit and Low Limit dials to desired temperatures.
- See control manufacturer specific instructions for details on operation and settings.
- See Figures #20 and #21 for wiring connections.

Figure #19 - Hydrostat 3250 Hi-Limit/Low Water Cutoff Control

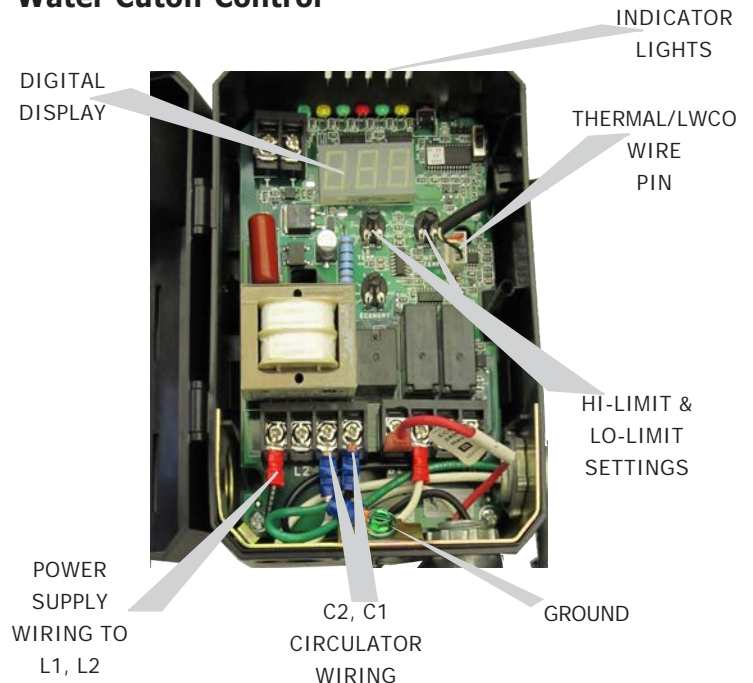

12.2 Sequence Of Operations

On call for heat, thermostat will actuate, completing circuit to limit. In turn, circulator and ignition systems are activated and ignition will begin.

In event boiler water temperature exceeds high limit setting on boiler mounted limit, power will be interrupted between limit and ignition system. Power will remain off until boiler water temperature drops below high limit setting. Circulator will continue to operate under this condition until thermostat is satisfied.

13 - ELECTRICAL WIRING

Figure #20 - Wiring Diagram Beckett AFG and Riello 40F10 with or without Tankless Heater

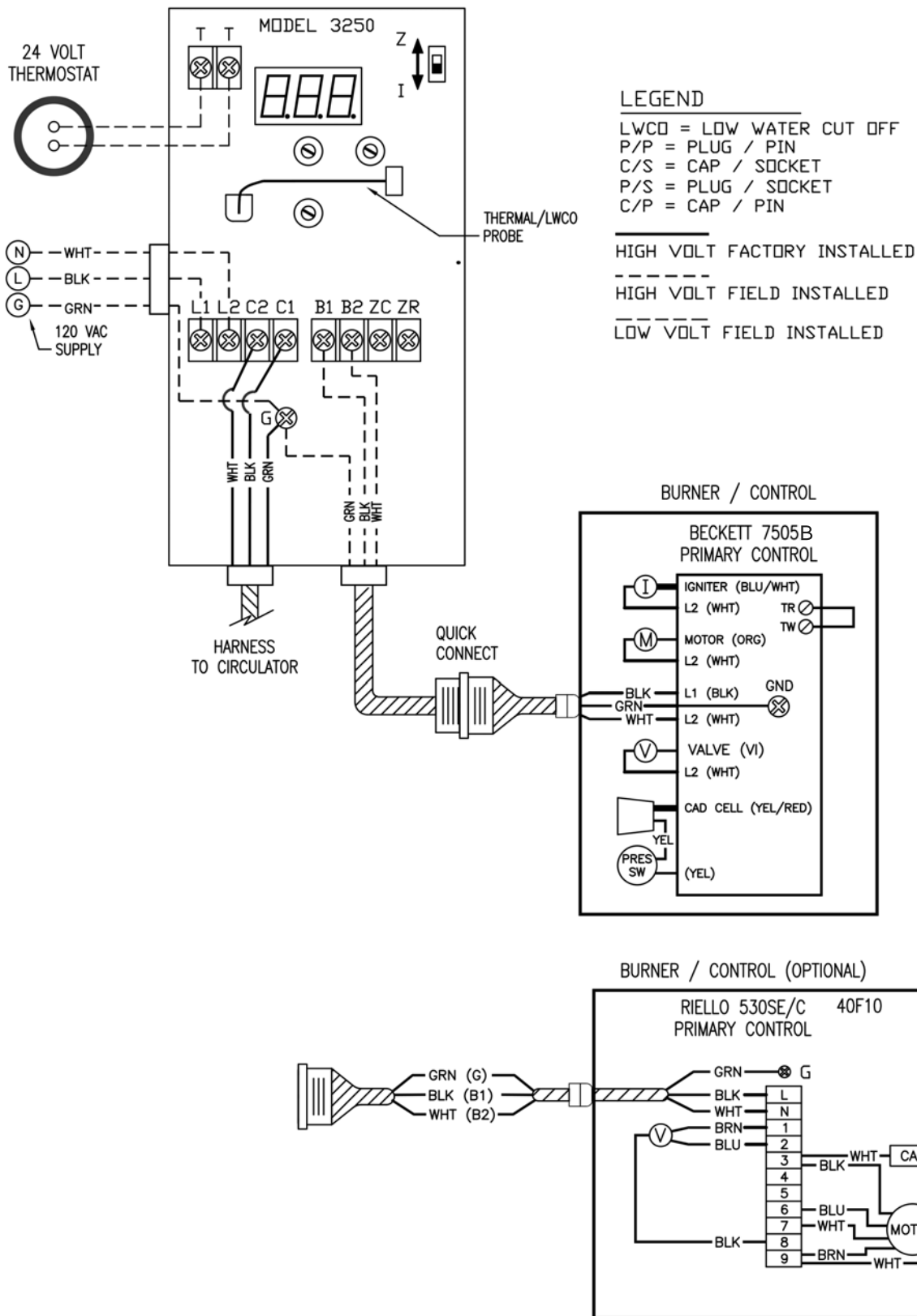

Note: Limit control program based on use with or without tankless heater. Refer to Hydrostat 3250 provided with boiler for additional information.

Figure #21 - Wiring Diagram Carlin EZ-1/2 and Riello 40F5 with or without Tankless Heater

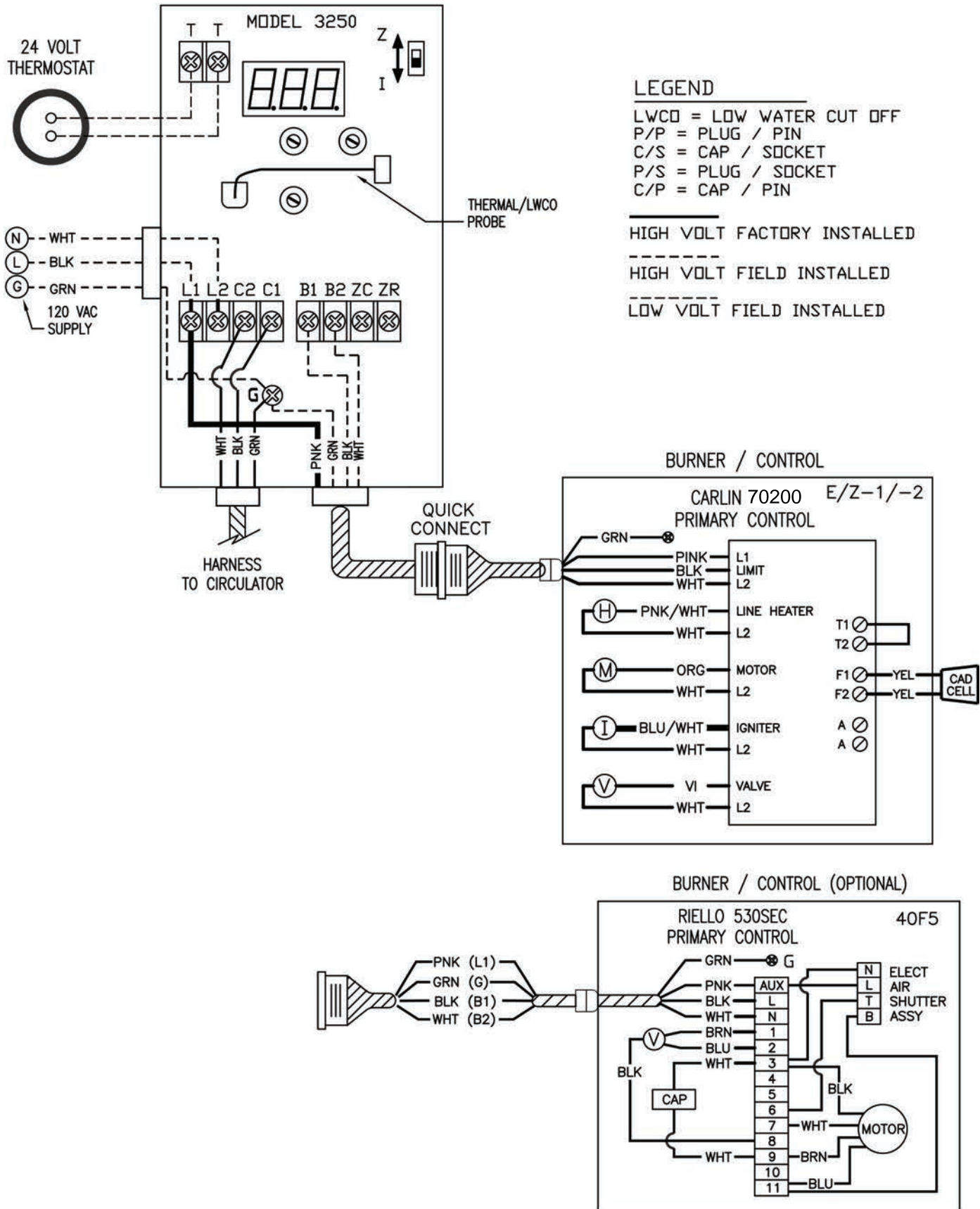

Note: Limit control program based on use with or without tankless heater. Refer to Hydrostat 3250 provided with boiler for additional information.

14.1 Operating Instructions

1. Inspect venting system at start of each heating season.
2. Check vent pipe from boiler to chimney for signs of deterioration by rust or sagging joints. Repair if necessary.
3. Remove vent pipe at base of chimney or flue and, using mirror, check for obstruction.

14.2 Safety Relief Valve - Follow valve manufacture specific instructions for operation and maintenance.

⚠ WARNING

Burn, scald hazard. Do not attempt to start the burner when excess oil has accumulated, when the unit is full of vapor, or when the combustion chamber is very hot.

NOTICE

Use only number 2 fuel oil. Do not use gasoline, crankcase drainings or any oil containing gasoline.

14.3 Start-Up And Adjustment Of Oil Burner

(See oil burner instructions for nozzle and electrode setting)

- Check oil nozzle in burner for size, angle and type, inspect electrode settings, check head setting, check air band and air shutter settings. See Oil Burner, Nozzle, & Air Settings page 26.
- DO NOT install burner without gasket. Place oil burner gasket on face of burner swing door with 4 burner flange bolts installed part way.
- Align round part of key hole slots of burner flange with burner door bolts. Turn burner to lock in place.
- Tighten all 4 cap screws using diagonal sequence.
- Plug burner power cord into burner harness.
- Attach flexible oil hose included in parts box.

Do not make firing adjustments visually. Instruments are only reliable method to determine proper air adjustments. Improperly adjusted burner causes soot and high fuel bills because of incomplete combustion of fuel oil. This in turn may require excessive boiler maintenance, service costs, and in some instances, house cleaning or redecorating. A competent service mechanic should be consulted to make proper adjustments with smoke tester, CO₂ indicator and draft gauge.

14.4 Instructions For Proper Operation Of Boiler Burner Unit

A ¼" diameter slot is provided in inspection cover plate to take draft readings in combustion chamber. See Figure #22. A ¼" diameter hole will be required in flue pipe between boiler and barometric damper to take draft, CO₂, smoke and temperature readings. Adjust air shutter on oil burner to obtain "trace" of smoke. Measure CO₂ at this point. Increase air adjustment to lower CO₂ approximately one (1) percent. Check to insure minimum negative .02" w.c., (water column), "overfire" draft and zero (0) smoke. If - .02" w.c. "overfire" draft can not be maintained, changes and/or modifications may be required in venting or chimney.

Tables on page 26 are provided as guidelines for initial start-up. Final adjustments shall be made using combustion instruments.

14.5 Check Safety Control Circuit - See Figure #19

High Limit (HL)

- A. Verify burner adjustments have been made.
- B. Place boiler in operation.
- C. Locate High Limit control. Open control cover and locate dial setting on Economy Switch. Turn Economy dial to off position. Economy light should be off.
- D. Note dial setting on High Limit Switch - HI Temp indicator light should be off. Lower dial set point unit limit switch turns burner off. Hi-limit light is now lit, indicating limit switch setting is exceeded.
- E. To reset the limit - set dial setting to original position. Indicator light will turn off when limit setting is satisfied. Set Economy switch to original setting.
- F. Close control cover.

Low Water Cutoff (LWCO)

- A. With boiler operating locate test/setting buttons near indicator light panel. Press and hold button for five (5) seconds or more. Digital display shows LCO and red LWCO light will illuminate. Burner circuit will shutoff if operating properly.
- B. After five (5) seconds display automatically returns to show actual boiler temperature (default). LWCO indicator light, red, will shut off if there is no actual low water condition sensed.
- C. Burner operation can now be restored.

Primary Control And Flame Sensor

- A. **Flame failure** - simulate by shutting off oil supply with hand valve while burner is on. After flame extinguishes, control goes through recycle period and attempts another ignition then locks out. To restart, open oil supply valve and reset safety switch. Refer to instructions included with burner.

14 - OPERATING INSTRUCTIONS

B. Ignition failure - with burner off, close oil supply valve and run through start-up procedure, The safety switch should lock out as in flame failure.

C. Power failure - Turn off main power supply switch while burner is operating. When burner stops, restore power and burner should start.

If operation is not as described as above, check wiring and controls.

14.6 Preventive Maintenance -

Inspect boiler and vent pipe for accumulation of soot or scale deposits periodically, at least once every year before start of each heating season. When soot is present on section walls and flueways, improper combustion will result, causing additional sooting and scaling until flueways are completely closed. To remove soot and scale from flueways, remove top jacket panel, top clean-out plate, open burner swing door. See Figure #22.

Periodic inspection and tightening of tankless heater/cover plate bolts will reduce risk of leaks.

14.7 Instructions For Opening Burner Swing Door

1. Turn off power to boiler.
2. Allow boiler to cool down.
3. Disconnect power cable at burner electrical quick connect. See Figure #22.
4. Loosen screws on the sides of lower front jacket panel.
5. Pull bottom part of lower front panel forward.
6. Lift lower front panel up and off boiler.
7. Close oil shutoff valve. See Figures #17 & #18.
8. Disconnect oil line from burner.
9. Do not try to swing door with oil line attached.
10. Remove nut from swing door stud on right hand side of door.
11. Swing open burner and door to the left.

14.8 Instructions For Closing Burner Swing Door

1. Swing burner and door to right until insulation is slightly compressed and stud is exposed.
2. Attach nut to stud and tighten until built in stop contacts the mounting door.
3. Replace oil line to burner.
4. Replace lower jacket panel, and tighten screws.
5. Connect power cable at burner electrical quick connect.
6. Turn on power to boiler. Open oil shutoff valve.
7. Bleed oil line.

14.9 Start of Heating System

- Using flue brush, brush soot and scale into combustion space where it can be removed through swing door opening.
- It is recommended to replace nozzle at start of each heating season.
- Lubricate burner motor and circulator motor - if required - with few drops of good grade light motor oil. Do not over oil.
- Have service agent service burner, check controls and check electrodes for carbon or cracks in insulators.
- Set burners to produce conditions shown in Start-up and Adjustment of Oil Burner procedure as stated in this section.
- Use caution when vacuuming in chamber area. Damage to chamber could result.

Figure #22

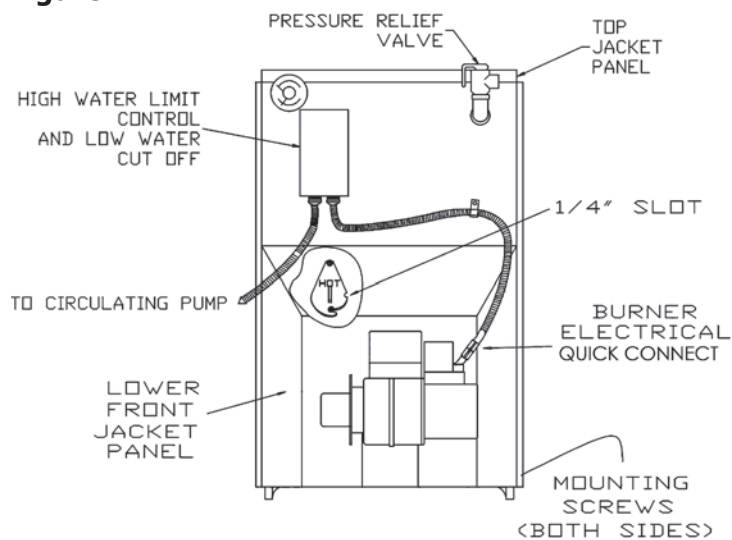

15 - BURNER SETTINGS

TABLE 3 -BECKETT AFG SETTINGS

BOILER NO.	HEAD TYPE	HEAD SETTING	STATIC PLATE	NOZZLE	PUMP PRESSURE [PSI]	AIR BAND	AIR SHUTTER
SFH-3085W(T)	L1	--	3 $\frac{3}{8}$	0.75-60°B	140	0	8
SFH-4100W(T)	V1	0	2 $\frac{3}{4}$	0.85-60°B	140	0	6
SFH-4125W(T)	V1	0	2 $\frac{3}{4}$	1.10-60°B	140	1	8
SFH-5160W(T)	F12	--	2 $\frac{3}{4}$	1.35-70°B	140	1	10
SFH-6185W(T)	F12	--	--	1.65-70°B	125	2	10

TABLE 4 - RIELLO 40F5/40F10 SETTINGS

BOILER MODEL	RIELLO BURNER MODEL	BURNER INSERTION [INCHES]	NOZZLE	PUMP PRESSURE [PSI]	TURBULATOR SETTING	AIR GATE SETTING
SFH-3085W(T)	40F5	2.25	0.70x80°W	145	0.0	2.0
SFH-4100W(T)	40F5	2.25	0.85x80°W	145	1.0	2.55
SFH-4125W(T)	40F5	2.25	1.00x80°W	155	2.0	4.0
SFH-5160W(T)	40F5	2.25	1.35x60°W	145	4.0	5.75
SFH-6185W(T)	40F10	4.75	1.65x45°B	125	2.0	3.4

TABLE 5 - CARLIN EZ-1/2 SETTINGS

BOILER MODEL	BURNER MODEL	FIRING RATE	NOZZLE MFR.	NOZZLE TYPE	PUMP PRESSURE [PSI]	HEAD BAR	AIR BAND SETTING	AIR SHUTTER
SFH-3085W(T)	EZ-1HP	0.85	DELAVAN	0.75 x 70 B	130	0.75	45%	BLANK
SFH-4100W(T)	EZ-1HP	1.00	DELAVAN	0.85 x 70 B	140	0.85/1.00	52%	BLANK
SFH-4125W(T)	EZ-1HP	1.25	DELAVAN	1.00 x 70 B	155	0.85/1.00	70%	BLANK
SFH-5160W(T)	EZ-2HP	1.60	DELAVAN	1.35 x 70 B	140	0.85/1.00	20%	3 SLOT
SFH-6185W(T)	EZ-2HP	1.85	DELAVAN	1.65 x 60 B	125	1.65/1.75	32%	3 SLOT

Above settings are preliminary settings only. Final adjustments must be made using combustion test instruments as previously outlined in the Operating Instructions



Table 6 - BOILER RATINGS

BOILER MODEL NUMBER		(1) OIL BURNER INPUT		(3) HEATING CAPACITY	(2) NET RATINGS WATER	(3) A.F.U.E.	CHIMNEY
		gph	*Mbh	*Mbh	*Mbh		
SFH-3085W	SFH-3085WT	0.85	119	103	90	86.0%	8X8X15
SFH-4100W	SFH-4100WT	1.00	140	124	108	87.0%	8X8X15
SFH-4125W	SFH-4125WT	1.25	175	152	132	86.0%	8X8X15
SFH-5160W	SFH-5160WT	1.60	224	195	170	86.0%	8X8X15
SFH-6185W	SFH-6185WT	1.85	259	226	197	86.0%	8X8X15

*Mbh = 1,000 Btu per hour [Btu = British Thermal Unit]

¹ Oil burner input based on 140,000 Btu per gallon.

² Net AHRI water ratings shown are based on a piping and pickup allowance of 1.15. Consult manufacturer before selecting a boiler for installation having unusual piping and pickup requirements, such as intermittent system operation, extensive piping systems, etc.

³ Heating Capacity and AFUE based on 13.0% CO₂ with -0.02" W.C. draft over fire and #1 smoke or less. Tested in accordance with U.S. Department of Energy test procedure.

T= Tankless

STANDARD EQUIPMENT: Crated Boiler, Flush Jacket, Oil Burner, Target Wall/Liner, Circulator- 1¼", Safety Relief Valve, Temperature Pressure Gauge, Drain Valve, Wiring Harness, Burner Electrical Disconnect, Plastic Cover, Supply Tapping-2", Return Tapping-1 1/2", High Limit, Low Limit and Circulator Control, Low Water Cut Off Primary Control. For Tankless Heater Units add Tankless Hot Water Coil.

Table 7 - TANKLESS WATER HEATER CAPACITIES

BOILER MODEL NUMBER	INPUT RATE G.P.H.	TANKLESS HEATER NUMBER	TANKLESS HEATER CAPACITY INTERMITTENT DRAW G.P.M.	BOILER WATER CONTENT GALS.
SFH-3085WT	0.85	T3	3	10.5
SFH-4100WT	1.00	T4	3¼	13.5
SFH-4125WT	1.25	T4	3¾	13.5
SFH-5160WT	1.60	T4	4	16.5
SFH-6185WT	1.85	T4	4¼	19.5

IMPORTANT

In accordance with Section 325 (f) (3) of the Energy Policy and Conservation Act, this boiler is equipped with a feature that saves energy by reducing the boiler water temperature as the heating load decreases. This feature is equipped with an override which is provided primarily to permit the use of an external energy management system that serves the same function.

THIS OVERRIDE MUST NOT BE USED UNLESS AT LEAST ONE OF THE FOLLOWING CONDITIONS IS TRUE:

- An external energy management system is installed that reduces the boiler water temperature as the heating load decreases.
- This boiler is not used for any space heating
- This boiler is part of a modular or multiple boiler system having a total input of 300,000 BTU/hr or greater.
- This boiler is equipped with a tankless coil.



2201 Dwyer Avenue, Utica, NY 13501
Tel. 800 253 7900
www.ecrinternational.com

All specifications subject to change without notice.
©2020 ECR International, Inc.