

Logamatic 4121, 4122 and 4126

For users

Read carefully before use

7 747 016 733 - 03/2008 GB/E

Buderus

1	Introduction	4
2	What you should know about your heating system.	5
3	Tips on energy-efficient heating	10
4	Safety	11
4.1	About these instructions	11
4.2	Correct use	11
4.3	Standards and guidelines/directives.	11
4.4	Symbol key	11
4.5	Please observe these notes.	11
4.6	Cleaning the control unit.	12
4.7	Disposal.	12
5	Controls and MEC2 programming unit	13
5.1	Control unit controls.	13
5.2	MEC2 programming unit.	15
5.3	Switching on the control unit	17
5.4	Switching off the control unit	17
6	Standard functions	18
6.1	Simple operation.	18
6.2	Permanent display	19
6.3	Selecting the operating mode.	20
6.4	Setting the room temperature.	23
6.5	Heating DHW.	25
7	Extended functions	28
7.1	Keys for extended functions	28
7.2	Controlling the extended functions.	29
7.3	Displaying operating values.	29
7.4	Changing the permanent display.	30
7.5	Setting the date and time	31
7.6	Selecting a heating circuit	33
7.7	Adjusting the room temperature for another heating circuit.	34
7.8	Heating circuits with MEC2 programming unit.	36
7.9	Selecting and modifying a heating program	37
7.10	Selecting a standard program	39
7.11	Summary of standard programs	40
7.12	Modifying the standard program by moving switching points	41
7.13	Setting the summer/winter time changeover.	44
7.14	Setting the DHW operating mode	46
7.15	Setting the operating mode for DHW circulation	47
7.16	Setting the holiday function	48

7.17	Interrupting and continuing the holiday function	50
7.18	Setting the party function	51
7.19	Setting the pause function	51
7.20	Room temperature matching.	52
7.21	Automatic maintenance message.	53
8	Additional programming options	54
8.1	Modifying the standard program by inserting/deleting switching points	54
8.2	Creating a new heating program	63
8.3	Creating a new DHW program.	66
8.4	Creating a new DHW circulation pump program.	67
8.5	Thermal disinfection	68
9	Modules and their functions	69
9.1	ZM424 central module.	70
9.2	FM441 function module (accessory)	72
9.3	FM442 function module (accessory)	74
9.4	FM445 function module (Logamatic 4126)	75
10	Boiler flue gas test	77
11	Troubleshooting	78
11.1	Simple troubleshooting	79
11.2	Troubleshooting.	80
12	Operation in the event of a fault	81
12.1	Emergency mode.	81
12.2	Manual mode Logamatic 4121.	82
12.3	Manual mode Logamatic 4126.	83
13	Setup report	84
14	Keyword index	85

1 Introduction

With your purchase of this Logamatic control unit you have acquired a product that promises you easy control over your heating system. It offers you optimum heating convenience and minimum energy consumption.

The control unit enables you to operate your heating system to be able to combine your economical and ecological aspirations. Of course, your personal comfort is always priority.

The control unit, which is regulated by the MEC2 programming unit, is set up at the factory for immediate use. Naturally, you or your heating contractor can modify these default settings and adapt them to your individual requirements.

The MEC2 programming unit is the central control unit.

Some functions which you may need are located behind a flap. The keys behind this flap enable you to make various adjustments.

**The control concept is:
"Push and turn"**

"This control unit speaks your language".

Your heating system offers a wealth of further useful functions. Some examples of these are:

- Automatic summer/winter time changeover
- Party/pause function
- Holiday function
- DHW heating at the touch of a button

2 What you should know about your heating system

Why should you become more familiar with your heating system?

Advanced heating systems offer many functions for saving energy without sacrificing comfort. Getting to know this heating technology may appear daunting at first, but after a short while you will recognise the advantages you can gain from a heating system that is set up to meet your personal requirements. The more you are aware of the options offered by your heating system, the greater the benefit you will be able to draw from it.

How does your heating system work?

Your heating system comprises the boiler with burner, heating control unit, pipework and radiators. A DHW cylinder or an instantaneous water heater heats the water required for a shower, bath or washing your hands. Subject to the way your heating system has been installed, it can operate either purely as a central heating system or together with a DHW cylinder. The important thing is that the various components match each other. The burner combusts fuel (e.g. gas or oil) and heats the water inside the boiler. Using pumps, this hot water is transported through the pipework to the consumers (radiators, underfloor heating system, etc).

Fig. 1 shows the heating circuit of a pumped central heating system: The burner [2] heats the water inside the boiler [1]. This heating water is transported by the pump [3] through the flow line [4] to the radiators [6]. The heating water flows through the radiators, and in doing so, gives off some of its heat. The heating water flows back to the boiler via the return line [7], where the cycle starts again.

The room temperature can be adjusted to your personal requirements using the thermostatic radiator valves [5]. All radiators are supplied with the same flow temperature. The heat transferred to the room depends on the radiator surface and the heating water throughput. Therefore, the heat transfer can be manipulated via the thermostatic radiator valves.

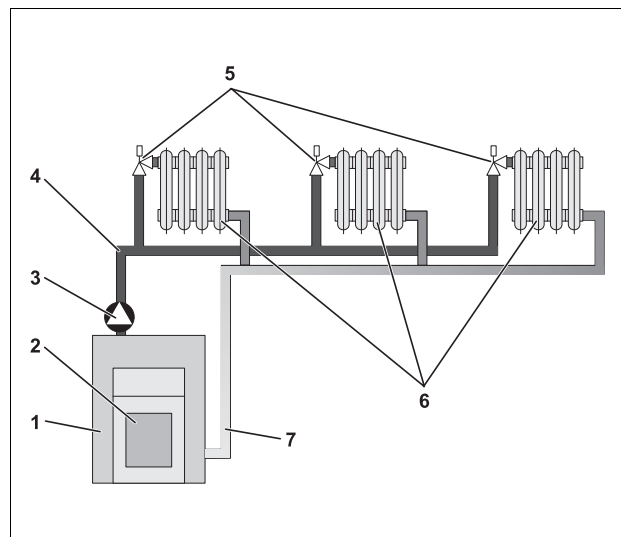

Fig. 1 Pumped central heating design

- 1 Boiler
- 2 Burner
- 3 Pump
- 4 Flow line
- 5 Thermostatic radiator valves
- 6 Radiators
- 7 Return line

What determines the heat demand of a room?

The heat demand of a room largely depends on the following factors:

- Outside temperature
- Required room temperature
- Type of construction/insulation of the building
- Wind chill factor
- Radiant energy from the sun
- Internal heat sources (open fireplace, occupants, lamps, etc.)
- Closed or open windows

Take these factors into consideration to achieve a comfortable room temperature.

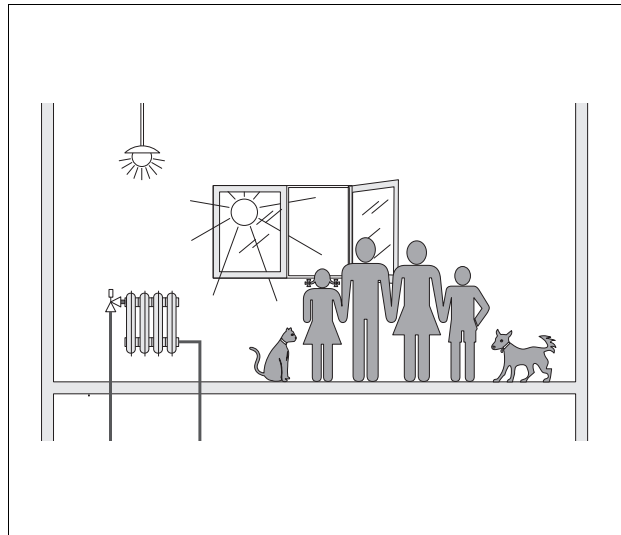

Fig. 2 Influences on the room climate

Why do you need a control unit?

The control unit ensures convenient heat and economical consumption of fuel and electrical energy. It starts the heat source (boiler and burner) and pumps when warm rooms or DHW are required. In doing so, it utilises the components of your heating system at the correct time.

Furthermore, your control unit records different variables that influence the room temperature and compensates for these.

What does the control unit calculate?

Advanced control units calculate the temperature required within the boiler (the so-called flow temperature) subject to the outside temperature. The relationship between the outside temperature and the flow temperature is described as the heating curve. The lower the outside temperature, the higher the flow temperature must be.

The control unit can operate in three control modes:

- Weather-compensated control
- Room temperature-dependent control
- Weather-compensated control with room temperature hook-up

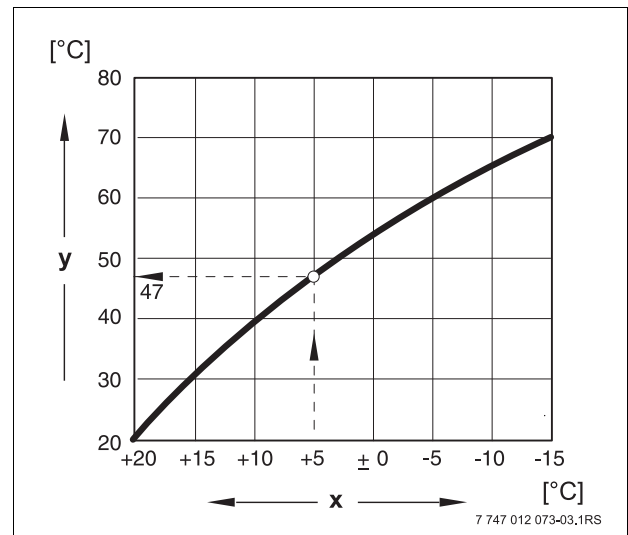

Fig. 3 Heating circuit curve (example)

x Outdoor temperature

y Flow temperature

Weather-compensated control

With weather-compensated control, only the outside temperature captured by the outside temperature sensor is decisive for the flow temperature level. Room temperature fluctuations through radiant energy from the sun, occupants, open fireplaces or similar external heat sources are then ignored.

If you utilise this type of control, adjust the thermostatic radiator valves so that the required room temperature is achieved in the different rooms.

Room temperature-dependent control

A further possible heating control method is room temperature-dependent control. The control unit calculates the flow temperature based on the set and actual room temperature.

To be able to utilise room temperature-dependent control, you need a room that is representative of your whole home. All factors influencing the temperature in this "reference room" – where the programming unit is located – will also apply to all other rooms. Not every home has a room that meets these requirements. Pure room temperature-dependent control has, in such cases, certain limitations.

Should you, for example, open a window in the room where the room temperature is measured, the control unit will "think" that you have opened the windows in every room in your house and will begin to heat vigorously.

Or the reverse might apply: You measure the temperature in a south-facing room with different heat sources (solar or other heat sources, e.g. an open fireplace). Now the control unit "thinks" that it is as hot in every room as in the reference room; consequently the boiler output will be severely reduced so that, for example, the north-facing rooms will become too cold.

With this kind of control you always need to keep all thermostatic radiator valves in the reference room fully open.

Weather-compensated control with room temperature hook-up

Weather-compensated control with room temperature hook-up combines the advantages of the other two control modes. The required flow temperature, which is mainly subject to the outside temperature, can be adjusted by the room temperature only to a limited degree. This achieves improved maintenance of the room temperature within the room containing the programming unit, without completely ignoring the other rooms.

With this kind of control you will also need to keep all thermostatic radiator valves in the reference room fully open.

Why do the thermostatic valves have to stay fully open?

If, for example, you want to reduce the room temperature in the reference room, and you therefore close the thermostatic valve further, the flow rate through the radiator is reduced and, therefore, less heat is transferred to the room. This reduces the room temperature. The control unit will endeavour to counteract the drop in room temperature by raising the flow temperature. However, raising the flow temperature does not raise the room temperature, as the thermostatic valve continues to limit the room temperature.

An excessive flow temperature results in unnecessary heat losses from boiler and pipework. At the same time, the temperature in all rooms without thermostatic valves increases due to the higher boiler water temperature.

Why do I need a time switch?

Advanced heating systems are equipped with a time switch to save energy. With a time switch you can set up an automatic changeover between two different room temperatures, subject to time. This enables you to set a reduced room temperature at night, or other times when a reduced temperature is sufficient, whilst operating your heating system with the standard room temperature during the day.

You have four options for reducing the room temperature via the control unit. Upon request, your heating contractor will select and set up one of these options:

- Total shutdown (no room temperature regulation)
- Reduced room temperature (a reduced room temperature will be regulated)
- Change between total shutdown and reduced heating subject to room temperature
- Change between total shutdown and reduced heating subject to outside temperature

With **total shutdown** of the heating system, no pumps or other system components are controlled. Heating only recommences if the heating system is subject to a risk of frost.

Heating with reduced room temperature (night mode) only differs from standard heating mode (day mode) through a lower flow temperature.

When **changing from total shutdown to reduced heating**, total shutdown is activated subject to **room temperature** when the actual room temperature exceeds the set room temperature. This function is only possible if a room temperature is being captured.

When **changing from total shutdown to reduced heating**, total shutdown is activated subject to **outside temperature** when the actual outside temperature exceeds the set outside temperature.

What are heating circuits?

A heating circuit describes the circuit taken by the heating water from the boiler via the radiators and back again (→ Fig. 1, page 6). A simple heating circuit comprises a heat source, a flow line, a radiator and a return line. A pump installed in the flow line circulates the heating water.

Several heating circuits may be connected to one boiler, for example, one heating circuit for supplying radiators and a further circuit for supplying an underfloor heating system. In this case, the radiators are supplied at a higher flow temperature than the underfloor heating system.

The supply of different flow temperatures to different heating circuits can be achieved by e.g. installing a three-way mixing valve between the heat source and the underfloor heating system.

Using an additional temperature sensor in the flow of the heating circuit to be supplied, sufficient cold return water is mixed via a three-way mixing valve into the hot flow water, to achieve the required lower temperature. It is important to note that heating circuits with three-way mixing valves require an additional pump. This pump enables the second heating circuit to be operated independently of the first heating circuit.

3 Tips on energy-efficient heating

Here are a few tips on how to heat economically, without sacrificing convenience:

- Only heat if you need warmth. Utilise the preset heating programs (standard programs) in the control unit, or those that have been tailored to your individual requirements.
- Air rooms correctly during the heating season:
Open windows three to four times a day for approximately 5 minutes. Having the window slightly open all the time does not provide an air change and wastes valuable energy.
- Close the thermostatic valves whilst ventilating.
- Windows and doors are places where a lot of heat is lost. Therefore, check whether the doors and windows are correctly sealed. Shut your roller shutters (if installed) at night.
- Never position large objects such as a sofa or a desk immediately in front of radiators (minimum clearance 50 cm). Otherwise, the heated air cannot circulate and heat the room adequately.
- In rooms you occupy during the day, you can, for example, set a room temperature of 21 °C, whilst 17 °C may be sufficient at night. To achieve this, use the standard heating mode (day mode) and the setback mode (night mode, → Chapter 6).
- Never overheat rooms; overheated rooms are unhealthy, plus they waste money and energy. If you reduce the day room temperature, for example from 21 °C to 20 °C, you can save approximately six percent of your heating bill.
- Also heat in an energy-conscious manner in spring and autumn, and utilise the summer/winter time changeover (→ Chapter 7).
- A pleasant room climate not only depends on the room temperature, but also on the relative humidity. The drier the air, the cooler a room feels. You can optimise the relative humidity with house plants.
- You can also save money when heating DHW: Only operate the DHW circulation pump via a time switch. Research has shown that it is generally sufficient to run the DHW circulation pump for only three minutes every half hour.
- Arrange for your local heating contractor to service your heating system annually.

4 Safety

4.1 About these instructions

These operating instructions contain important information for the safe and correct operation of the Logamatic 4121, 4122 and 4126 control units.

4.2 Correct use

The Logamatic 4121, 4122 and 4126 control units are designed to control and monitor heating systems with different types of boiler in detached houses, apartment buildings, residential complexes and buildings with medium to large heat demand.

4.3 Standards and guidelines/directives



The design and operation of this product conform to European Directives and the supplementary national requirements. Its conformity is demonstrated by the CE designation.

You can view the Declaration of Conformity on the internet at www.buderus.de/konfo or request a copy from your local Buderus sales office.

4.4 Symbol key

Two levels of danger are identified and signified by the following terms:



WARNING!

RISK TO LIFE

Identifies possible risks associated with a product that might lead to serious injury or death if appropriate care is not taken.



CAUTION!

RISK OF INJURY/ SYSTEM DAMAGE

Indicates a potentially dangerous situation which could lead to minor or moderately serious injuries or to damage to property.



USER INFORMATION

User tips for the optimum utilisation and adjustment of the appliance plus other useful information.

4.5 Please observe these notes

- Only operate the control unit as intended and if it is in perfect working order.
- Let your local heating contractor instruct you thoroughly in the operation of this system.
- Read these operating instructions carefully.
- Only enter or change the operating values detailed in these instructions. Other entries alter the control programs of the heating system and can lead to incorrect system functions.
- Maintenance and repairs as well as troubleshooting should only be carried out by authorised and qualified personnel.



WARNING!

RISK TO LIFE

from electric shock.

- Never open the control unit.
- In an emergency, switch off the control unit (e.g. with the heating system emergency stop switch) or isolate the heating system from the mains supply by removing the main fuse.
- Arrange for your local heating contractor to rectify any heating system faults immediately.



CAUTION!

RISK OF INJURY/ SYSTEM DAMAGE

from operator error.

Operator errors can result in injury and/or damage to property.

- Ensure that children never operate the appliance unsupervised or play with it.
- Ensure that only personnel able to operate the appliance correctly have access to it.

**WARNING!****RISK OF SCALDING**

For thermal disinfection, the entire DHW system is set at the factory to heat up to 70 °C (start: Tuesday night at 01:00 h).

- If required (e.g. shift work), your local heating contractor can alter the start time.
- During this time, never open any hot water tap without mixing in cold water if the DHW circuit of your heating system is not equipped with a thermostatic mixer.
- As there is a risk of scalding at temperatures above approximately 60 °C, ask your local heating contractor about the set DHW temperatures.

**CAUTION!****SYSTEM DAMAGE**

from frost!

When the heating system is switched off, it can suffer damage from frost.

- Protect your heating system against frost damage by draining it and the DHW pipework at the lowest possible point.

4.6 Cleaning the control unit

- Only clean the control unit with a damp cloth.

4.7 Disposal

- Dispose of the control unit packaging in an environmentally responsible manner.
- The lithium battery in the CM431 module may only be replaced by your local heating contractor.

5 Controls and MEC2 programming unit

5.1 Control unit controls

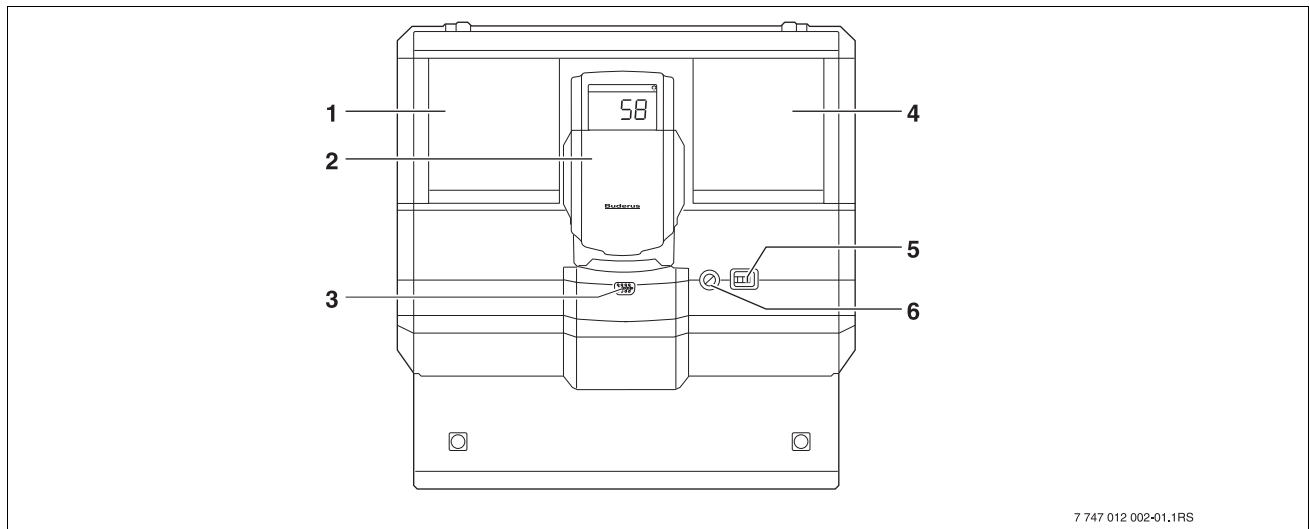

Fig. 4 Controls (example: Logamatic 4122)

- | | |
|--|--------------------|
| 1 Slot 1 | 4 Slot 2 |
| 2 ZM435 boiler display | 5 ON/OFF switch |
| 3 Connection for external service equipment and MEC2 | 6 Fuse 10 A (slow) |



USER INFORMATION

The Logamatic 4122 control unit is also available with the MEC2 programming unit.



USER INFORMATION

The system flow temperature is displayed on the boiler display.

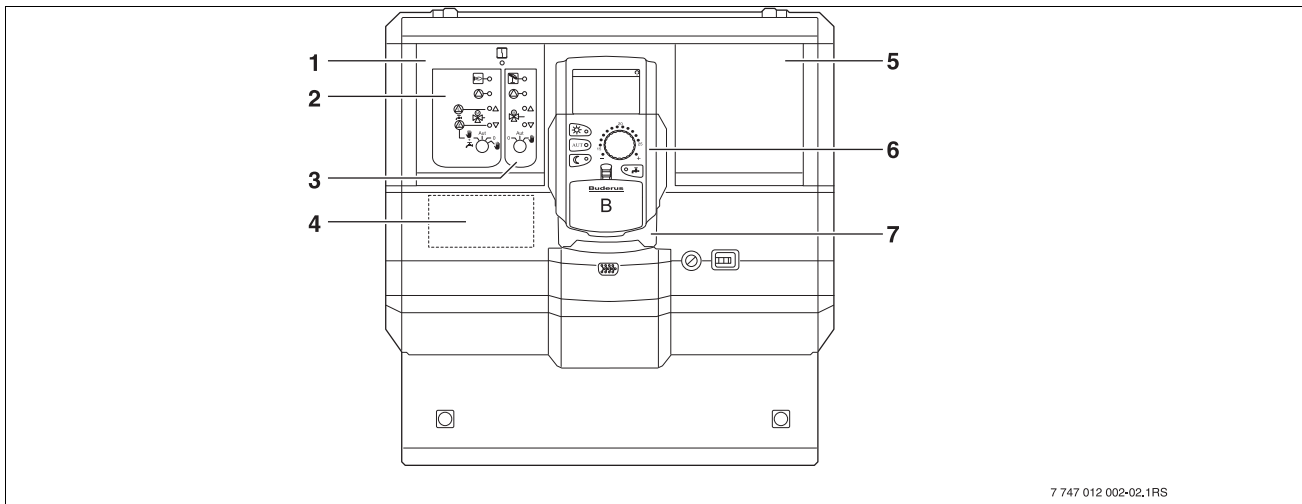

Fig. 5 Fitted modules (example: Logamatic 4121)

- | | |
|---|-----------------------------------|
| 1 Slot 1 for ZM424 module, comprising: | 5 Slot 2 for an additional module |
| 2 Heating circ 1 – mixed
alternative: Heating circ 1 – unmixed + DHW and DHW circulation | 6 MEC2 |
| 3 Heating circ 2 – mixed | 7 CM431 |
| 4 Slot A for FM455 module KSE1 | |



USER INFORMATION

For the Logamatic 4126 control unit, the FM445 module is installed in slot 1 (DHW via primary system) (→ Chapter 9.4).

5.2 MEC2 programming unit

The MEC2 programming unit is the central element with which you operate your Logamatic 412x control unit.

Display

The display (→ Fig. 6, [4]) indicates functions and operating values, e.g. the actual room temperature.

Rotary selector

The rotary selector (→ Fig. 6, [5]) is used to set new values and scroll through the menus.

Keys

You control the functions via the keys, and the relevant indications appear on the display. If you push a key and hold it down, you can change a value using the rotary selector.

The new value will be accepted and saved after you release the key.

You can reach certain functions, such as day room temperature, night room temperature, and possibly the DHW temperature or automatic heating mode, directly via the corresponding keys (→ Fig. 6, [1] to [3] and [6]).

Behind a flap (→ Fig. 6, [7]), further keys are available for additional settings, e.g. for the entry of weekdays or setting the current time.

The unit automatically returns to the standard display if no entry is detected for some time.

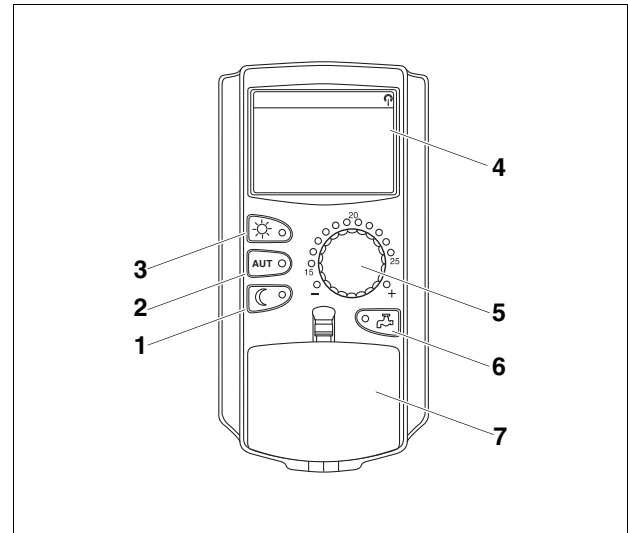
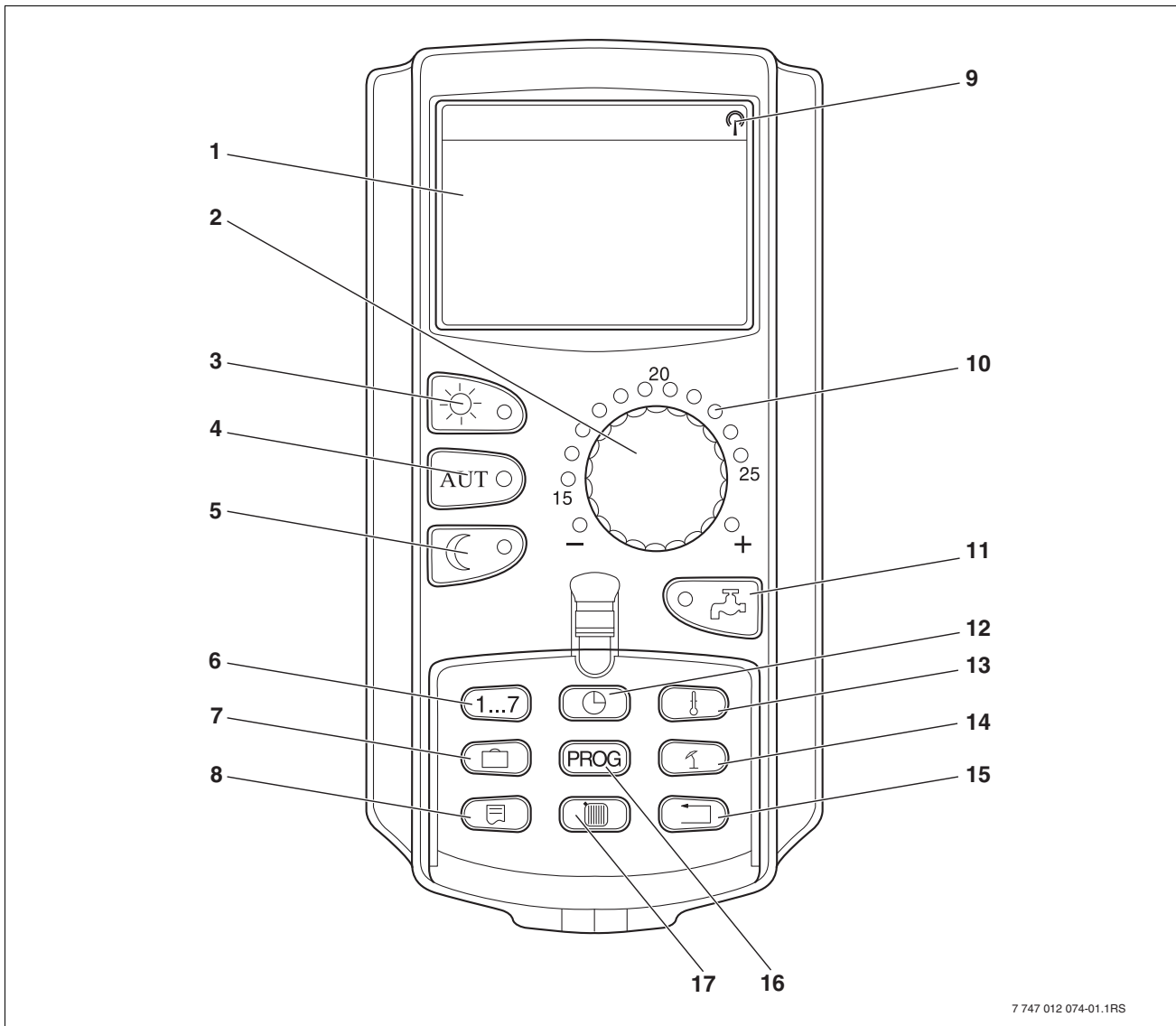

Fig. 6 MEC2 programming unit

- 1 Constant setback mode
- 2 Automatic heating mode in acc. with a time switch
- 3 Constant heating mode
- 4 Display
- 5 Rotary selector
- 6 Enter DHW temperature/reheating
- 7 Flap for the keypad of control level 2



7 747 012 074-01.1RS

Fig. 7 MEC2 programming unit

- | | |
|---|--|
| 1 Display | 9 Radio clock signal (only within Germany) |
| 2 Rotary selector | 10 Display for set room temperature |
| 3 Constant heating mode | 11 Enter DHW temperature/reheating |
| 4 Automatic heating mode in acc. with a time switch | 12 Set the time |
| 5 Constant setback mode | 13 Change temperature values |
| 6 Enter the day of the week | 14 Summer/winter time changeover |
| 7 Enter holidays | 15 Back to the standard display |
| 8 Select standard display | 16 Select a time switch program |
| | 17 Select heating circuits/DHW circuit |

5.3 Switching on the control unit

- Check that the control unit ON/OFF switch and the switches on the fitted modules are set to "I" or "AUT".
- Switch the control unit on by setting the ON/OFF switch to "I" (→ Fig. 4, [5], page 13).

After approximately 2 minutes all modules fitted to the control unit are recognised, and the standard display is shown.

5.4 Switching off the control unit

- Switch the control unit off by setting the ON/OFF switch to "0" (→ Fig. 4, [5], page 13).
- When there is a risk: Isolate the heating system from the mains supply with the emergency stop switch upstream of the boiler room, or by removing the main fuse.

6 Standard functions

In this chapter you will find information about the standard functions of the MEC2 programming unit and their use. The standard functions are:

- Selecting the operating mode
- Setting the room temperature
- Setting the DHW temperature
- Heating DHW once

6.1 Simple operation

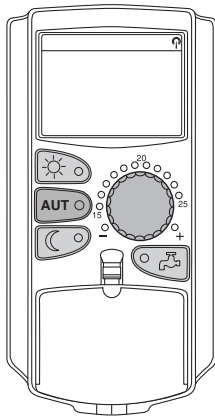

The standard functions are controlled by pressing one of the keys on the "Standard functions" keypad or by turning the rotary selector.

Example: Adjusting the room temperature for day mode



Press "Day mode" to select the standard heating mode (day mode). The LED of the "Day mode" key illuminates; day mode is enabled.



Set the required room temperature by turning the rotary selector. (Condition: For this, the programming unit flap must be closed.)

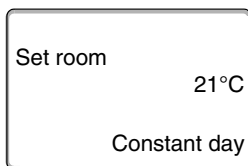

The display shows the set value.



USER INFORMATION

If your heating system is equipped with several heating circuits, first select the correct heating circuit (→ Chapter 7.6). Only then can you select the operating mode and room temperature.



USER INFORMATION

The following MEC2 displays only describe the possible displays:

- of the ZM424 module (standard equipment Logamatic 4121),
- of the FM456 and FM457 modules (cascade modules, accessories),
- and of the most frequently used FM441 and FM442 modules (accessories).

Subject to the way your heating contractor has configured your system, one or more MEC2 displays may not appear, although the above modules are fitted in your control unit.

Detailed descriptions of MEC2 displays for other modules are included in the corresponding module documentation.

6.2 Permanent display

There are two different permanent displays. Either one of the factory-set permanent displays is shown, subject to whether the MEC2 is fitted in a control unit or is installed as a wall mounted unit.

Factory-set permanent display, if the MEC2 is fitted in the control unit.

Common flow	45°C
Outside temp.	21°C

Factory-set permanent display, if the MEC2 is installed as a wall mounted unit.

Actual room	19.5°C
Outside temp.	0°C

6.3 Selecting the operating mode

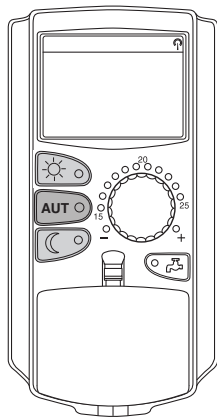

You can operate the MEC2 programming unit in two ways:

- In automatic mode
- In manual mode

Automatic mode

Generally, homes are heated less at night than during the day. With the MEC2 programming unit, you don't need to adjust the thermostatic radiator valves before bedtime or in the morning. The automatic changeover of the MEC2 programming unit does this for you. It changes over between day mode (standard mode) and night mode (setback mode).

The times at which your heating system changes from day to night mode – and vice-versa – are factory-set via standard programs (→ Chapter 7.10). However, you or your heating contractor can modify these settings (→ Chapter 7.12).

Manual mode

For example, if you want to heat longer in the evening or not quite as early in the morning, you can also select day and night mode manually (→ Chapter 6.3.2). You can also use manual mode to heat on cooler days when the system operates in summer mode.

6.3.1 Selecting automatic mode

In automatic mode your heating system will operate with the time switch program, i.e. central and DHW heating at preset times.

Example: Enabling automatic mode

Press "AUT".

The "AUT" LED illuminates; automatic mode is enabled.

In addition, either the "Day mode" or the "Night mode" LED will illuminate. This is subject to the set times for day and night mode.

Automatic day and night mode

At fixed times, central heating is provided or the room temperature is set back.

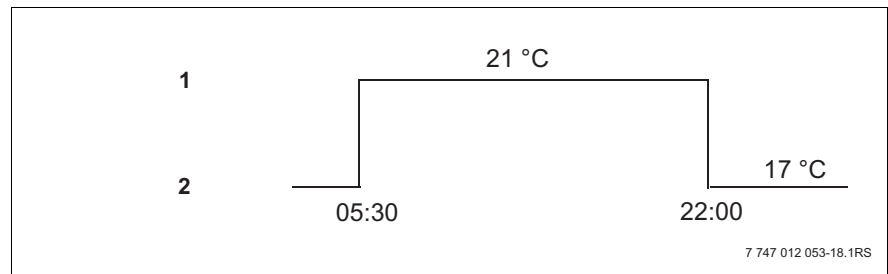
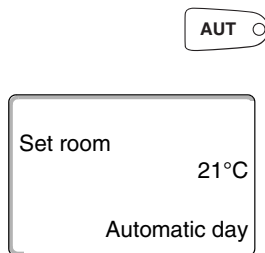

Fig. 8 Changeover from day and night mode at fixed times (example)

- 1 Day mode
- 2 Night mode

6.3.2 Selecting manual mode

Press either "Day mode" or "Night mode" to change to manual mode.

Press "Day mode".

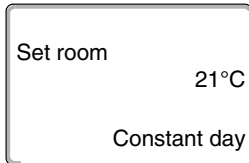

The "Day mode" LED illuminates. Now your heating system is in constant day mode (standard mode).

Press "Night mode".

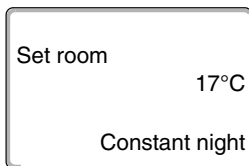

The "Night mode" LED illuminates. Your heating system is now in constant night mode (setback mode), and operates at a lower room temperature.



USER INFORMATION

If you have selected manual mode, other automatic controls will also be switched off, e.g. the summer/winter time changeover (→ Chapter 7.13).

6.4 Setting the room temperature

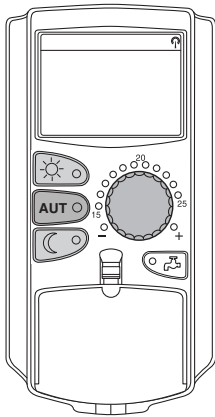

With the flap closed you can adjust the room temperature with the rotary selector. With the flap open, also press "Day mode" or "Night mode".

With the rotary selector, you can select the room temperature in degree steps between 11 °C (day), or 2 °C (night), and 30 °C. The set temperature is displayed via an LED next to the rotary selector. For temperatures below 15 °C or above 25 °C, the "-" or "+" LED illuminates.

The factory setting for the day room temperature is 21 °C.

The factory setting for the night room temperature is 17 °C.

Any adjustment applies to all heating circuits assigned to the MEC2 programming unit (→ Chapter 7.7).



USER INFORMATION

The set room temperature applies to the currently enabled heating mode, i.e. day or night mode. You can recognise the currently enabled heating mode because the green LED illuminates.

6.4.1 For the current operating mode

You are currently in automatic "Day mode" and would like to alter the room temperature.

(Condition: For this, the programming unit flap must be closed.)

Turn the rotary selector to the required day room temperature (here: "23°C").

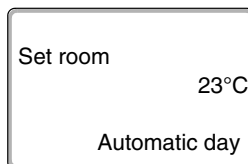

The day room temperature is now adjusted to 23 °C. The selected permanent display will then appear again.

6.4.2 For the operating mode not currently enabled

You may also adjust the room temperature for an operating mode that is not currently enabled.

For example, you are currently in automatic day mode and would like to alter the set night temperature.

Hold down "Night mode", and select the required night room temperature with the rotary selector (here: "16°C").

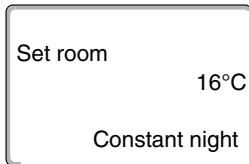

Release "Night mode".

The night setback temperature is now adjusted to 16 °C. The selected permanent display will then appear again.



Press "AUT".

The "AUT" LED illuminates; automatic mode is re-enabled.



USER INFORMATION

If you are currently in automatic night mode, and you wish to adjust the day mode, proceed as described above, but instead hold down "Day mode".

6.5 Heating DHW

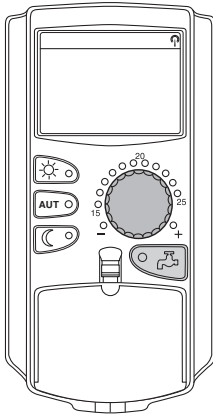

The programming unit also offers you the option of heating DHW in an energy-conscious manner. For this purpose, DHW heating can be selected via a time switch. You can select between the set values for DHW and "OFF", to stop DHW heating.

To save energy, DHW heating will be stopped outside the programmed times, i.e. DHW is not heated in night mode.

DHW heating is factory-set to 60 °C in automatic mode.

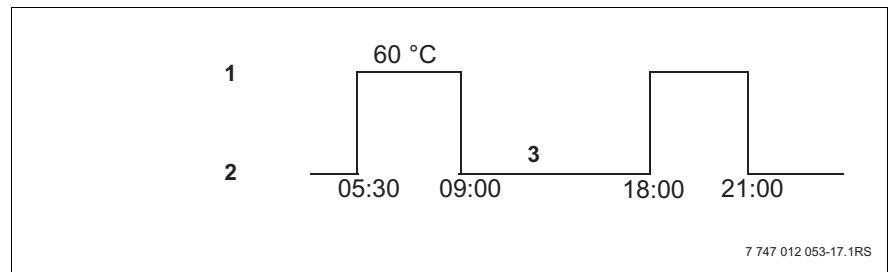

Fig. 9 Example: DHW heating

- 1 Day mode
- 2 Night mode
- 3 OFF

We recommend heating the DHW cylinder once in the morning, before central heating begins, and reheating once in the evening if necessary (see (→ Fig. 9).



USER INFORMATION

The DHW temperature will have fallen below the set value if the green "DHW" LED illuminates.

6.5.1 Setting the DHW temperature



WARNING!

RISK OF SCALDING

from hot water!

The DHW cylinder temperature is preset to 60 °C. There is a risk of scalding from hot water if your heating contractor has set the DHW temperature higher, or has enabled the "Therm. Disinfect" function, and the heating water circuit of your heating system is not equipped with a thermostatically controlled mixer. Please note that fittings can also get very hot.

- In such cases, only ever draw off mixed water (hot and cold).

You can change the DHW temperature as follows:

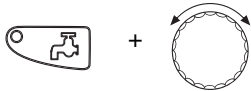

Hold down "DHW", and select the required DHW temperature with the rotary selector.

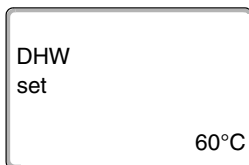

Release "DHW". The newly selected DHW temperature is saved within approximately 2 seconds. The permanent display will then appear again.



USER INFORMATION

For thermal disinfection, the DHW will be heated to at least 60 °C once or twice per week to kill off possible bacteria (e.g. legionella).

6.5.2 Heating DHW once

If the "DHW" LED illuminates, only a limited amount of hot water remains in the cylinder. Should you require a larger amount of DHW, proceed as follows:

Press "DHW".

The LED of the "DHW" key illuminates, and heating DHW once begins.

Subject to the size of the DHW cylinder and the boiler output, DHW will be available after approximately 10 to 30 minutes. With instantaneous water heaters, DHW is available almost immediately.

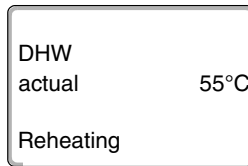

USER INFORMATION

For thermal disinfection, the DHW will be heated to at least 60 °C once or twice per week to kill off possible bacteria (e.g. legionella).

7 Extended functions

The extended functions are explained in this chapter. You need the extended functions to be able to change the factory settings of your heating system. You can use the following functions:

- Display the current operating values of your heating system
- Set the time
- Set the date
- Set heating circuits
- Select a heating program
- Set the room temperature for additional heating circuits

The keys for the extended functions are located behind the flap of the MEC2 programming unit.

7.1 Keys for extended functions

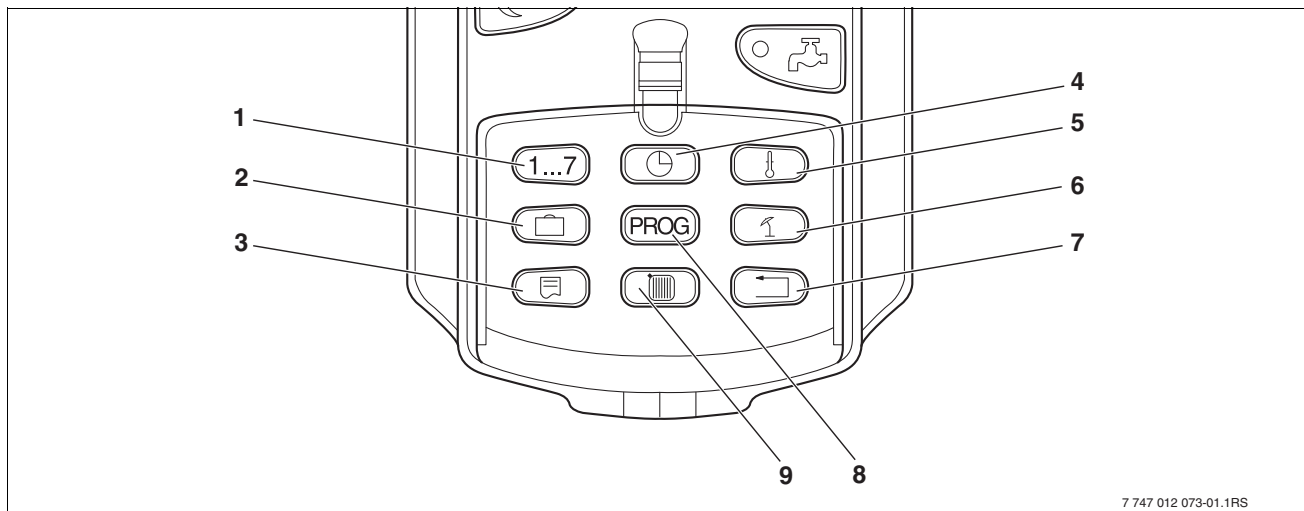

Fig. 10 Keys for the extended functions

- 1 Enter the day of the week
- 2 Enter holidays
- 3 Select standard display
- 4 Set the time
- 5 Change temperature values
- 6 Summer/winter time changeover
- 7 Return to the standard display
- 8 Select a time switch program
- 9 Select heating circuits/DHW circuit

7.2 Controlling the extended functions

The extended functions provide access to a further control level. At this level, proceed according to the "Push and turn" principle. The control procedure is always similar:

- Open flap.

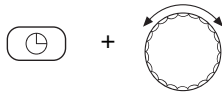

Hold the required key down, e.g. "Time", and simultaneously turn the rotary selector.

By turning the rotary selector you modify the values that flash on the display.

Release key. Modified values are saved.



"Back" key = Exit menu.

7.3 Displaying operating values

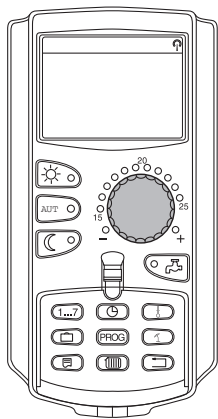

You can display and control the various operating values of the boiler, the selected heating circuit and the system.

Only the operating values of the selected heating circuit, e.g. heating circuit 0, are displayed (→ Chapter 7.6).



Turn the rotary selector clockwise without pressing any other key.

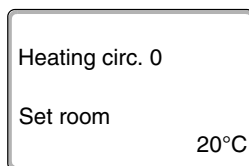

Subject to the modules, various of the following operating displays can be called up:

- Burner and hours run
- Actual heating circuit room temperature
- Set heating circuit room temperature
- Heating circuit operating state
- Actual heating circuit flow temperature
- Actual DHW temperature*
- Set DHW temperature*
- DHW operating mode*
- Operating state - DHW circulation pump and cylinder primary pump

*Only if a DHW function is installed.

7.4 Changing the permanent display

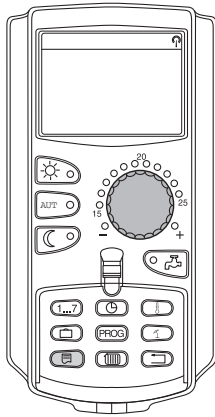

You can determine the permanent display of the programming unit.

The following permanent displays are available:

- System flow (if MEC2 is installed as a wall mounted unit)
- Outdoor temperature
- DHW*
- Time
- Date

**Only if a DHW function is installed.*

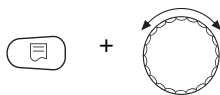

Hold down "Display", and select the required permanent display with the rotary selector (here: "Date").

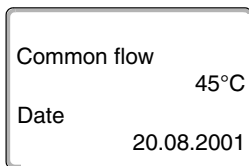

Release "Display". The selected permanent display has now been saved.

7.5 Setting the date and time



USER INFORMATION

Date and time are preset at the factory. This function is backed up by battery power independent of the mains power supply.

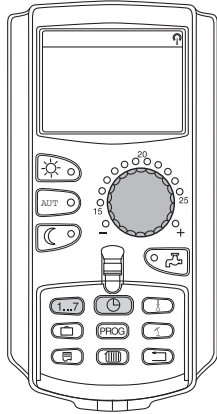

The MEC2 contains a radio receiver that, under normal reception conditions, constantly monitors and corrects the control unit time switch (if enabled).

Reception of the radio clock signal is indicated by symbol  on the display.



USER INFORMATION

We recommend leaving the radio clock receiver disabled outside Germany to prevent the reception of false signals (incorrect time setting).

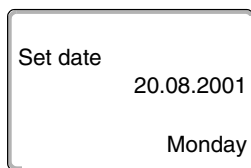
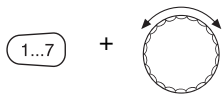

Set date

Hold "Weekday" down, and select the required date with the rotary selector (here: "20").

The name of the day automatically changes (here "Monday") if you set the date using the rotary selector (here "20").

Release "Weekday" to save your input.

Press "Weekday" again to enter the month.

Press "Weekday" again to enter the year.

The item flashing can be modified with the rotary selector.

Setting the time

Hold down "Time", and select the required time with the rotary selector.

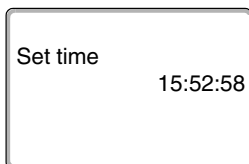
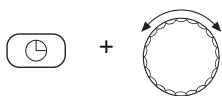

The time is set in one-minute steps.

Release "Time" to save your input.

7.6 Selecting a heating circuit

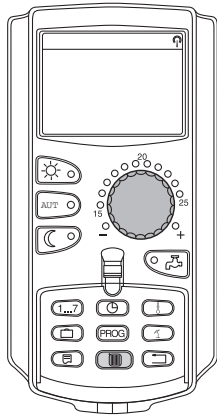

Your heating system may be equipped with several heating circuits. If you want to change a setting, e.g. the heating program, first select the heating circuit whose setting you want to change.

Subject to the equipment level of your heating system, the following heating circuits can be selected:

- MEC2 heating circuits (all heating circuits assigned to the MEC2
→ Chapter 7.8)
- Heating circuit 0 – 8
- DHW
- DHW circulation

- Open flap.

Hold down "Heating circuit", and select the required heating circuit with the rotary selector (here: "Heating circ. 2").

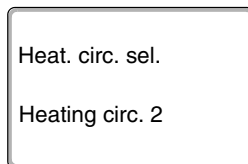
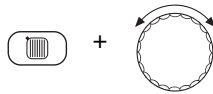

Release "Heating circuit". The displayed heating circuit is now selected.

As soon as the heating circuit has been selected, the display returns to the permanent display.

7.7 Adjusting the room temperature for another heating circuit

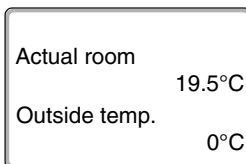
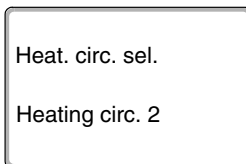
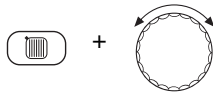
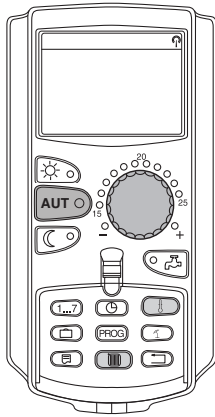

Your heating system may be equipped with several heating circuits. If you want to change the room temperature for a different heating circuit than the one last selected, first select the required heating circuit.

Subject to the equipment level of your heating system, the following heating circuits can be selected:

- MEC2 heating circuits (all heating circuits assigned to the MEC2 → Chapter 7.8)
- Heating circuit 0 – 8

If several heating circuits are assigned to the MEC2, the temperature for these heating circuits can only be adjusted for all. Otherwise a fault message "Setting Not possible. MEC heat. circ. select" will appear. In such cases select "MEC heat. circ.".

- Open flap.

Hold down "Heating circuit", and select the required heating circuit with the rotary selector (here: "Heating circ. 2").

Release "Heating circuit". The displayed heating circuit is now selected.

As soon as the heating circuit has been selected, the display returns to the permanent display.

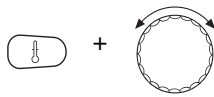

Press and hold down "Temperature". First, the heating circuit whose temperature you want to adjust is displayed. After approximately 2 seconds, the display will show the currently selected temperature and operating mode.

Adjust the temperature for the heating circuit with the rotary selector (here: "21°C").

Release the key to save your input.

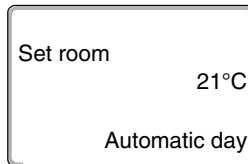

The day room temperature is now adjusted to 21 °C. The selected permanent display will then appear again.



USER INFORMATION

If you want to adjust the temperature for an operating mode that is not the current mode, first select the corresponding operating mode (e.g. by pressing "Night mode"). After modifying the temperature, reset the operating mode to the previous setting.



USER INFORMATION

For heating circuits with individual remote control units (e.g. BFU), you can adjust the room temperature only via these units (→ see remote control instructions).

7.8 Heating circuits with MEC2 programming unit

During installation, your heating contractor will determine which heating circuits are to be controlled by the MEC2 programming unit. These heating circuits will be designated "MEC heat. circ.".

MEC heat. circ.

The following adjustments made at the MEC2 apply all to "MEC heat. circ." simultaneously:

- Setting the room temperature
- Setting the summer/winter time changeover
- Selecting the operating mode
- Setting the holiday function
- Setting the party or pause function

Setting
Not possible
MEC heat. circ.
select

If you have selected an individual heating circuit that is assigned to the MEC2, and you want to make one of the above adjustments, the fault message "Setting Not possible. MEC heat. circ. select" will appear.

Select "MEC heat. circ." to program these settings (→ Chapter 7.6).

Individual heating circuits

The following adjustments can only be implemented for each individual heating circuit separately:

- Selecting the standard program
- Modifying the standard program by moving switching points
- Inserting or deleting switching points
- Deleting or connecting heating phases
- Creating a heating, DHW or DHW circulation pump program

Time switch
Not possible
Single heat circ
select

If you have selected "MEC heat. circ.", and you want to make one of the above adjustments, the fault message "Time switch Not possible. Single heat circ select" will appear.

Enter these settings for each heating circuit separately (→ Chapter 7.6).

7.9 Selecting and modifying a heating program

7.9.1 What is a heating program?

A heating program provides automatic changeover between operating modes (day and night mode) at fixed times. This automatic changeover is effected via a time switch.

Before you utilise this option, consider the following:

- At what time in the morning should your home be warm? Is this time also subject to the day of the week?
- Are there days when you don't want to heat?
- From what time in the evening do you no longer need to heat? This may also depend on the day of the week.

The length of time your heating system takes to heat up individual rooms may vary. This will be subject to the outside temperature, the building insulation and the room temperature setback.

The "Optimisation" function of the programming unit calculates the various heat-up times. Ask your heating contractor whether this function has been enabled. If so, all you need to do is enter the times at which your home should be warm.

With the programming unit, Buderus offers eight different, preset heating programs as standard programs.

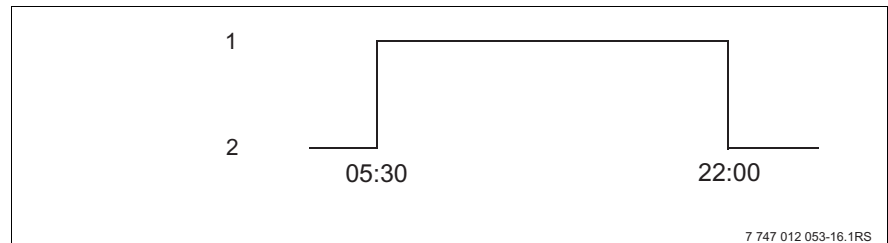

Fig. 11 Example for a standard program (here: "Family program" from Monday to Thursday)

- 1 Day mode
- 2 Night mode



USER INFORMATION

After commissioning, check whether the selected heating program suits your lifestyle. If not, several options are available for matching the heating program to your individual requirements.

7.9.2 Time switch program for DHW

You may enter your own heating program for DHW heating. This saves you energy.

Determine the time points so that DHW is only available when one heating circuit is in standard heating mode (day mode). In this case, DHW is heated 30 minutes before day mode of the first heating circuit, so it is available at the selected time.

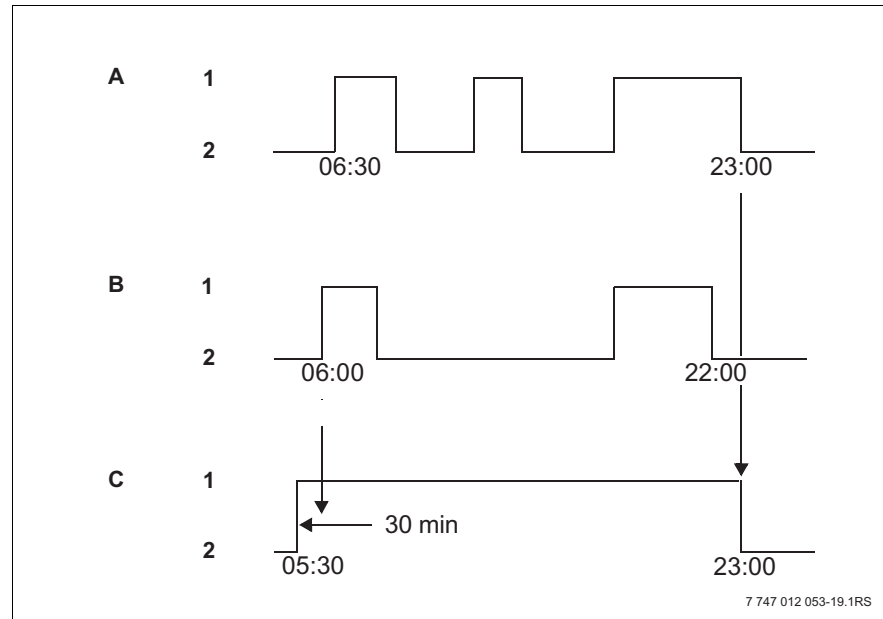

Fig. 12 DHW heating begins 30 minutes before day mode of the first heating circuit, and ends with the beginning of night mode of the last heating circuit.

- A Heating circ. 1
- B Heating circ. 2
- C DHW
- 1 Day mode
- 2 Night mode

If you require additional hot water, you may, at short notice, heat DHW with the "DHW heating once" function (→ Chapter 6.5.1).



USER INFORMATION

DHW will not be subject to a temperature setback if you operate one heating circuit in "Manual day" mode, and DHW is being heated "by heat. circs".



USER INFORMATION

DHW will not be heated if you are operating **all** heating circuits in the "Manual night" mode and DHW is heated "by heat. circs".

7.10 Selecting a standard program

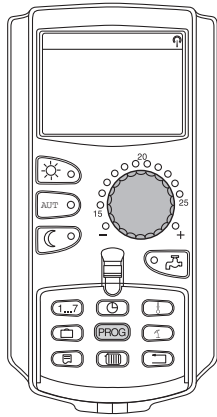

The MEC2 programming unit is equipped with eight different, preset heating programs that act as standard programs. See the following page for a summary of the preset times of the standard programs.

Please check which standard program best meets your requirements. First check the number of switching points, and then the times. The "Family" program is preset at the factory.

- Open flap.
- Select a heating circuit (→ Chapter 7.6).

Hold down "PROG". Initially the heating circuit is displayed for which you want to select a standard program. Approximately 2 seconds later the designation of the currently selected standard program will appear.

Select the required standard program with the rotary selector (here: "Seniors"). Release "PROG". The displayed program is now selected.

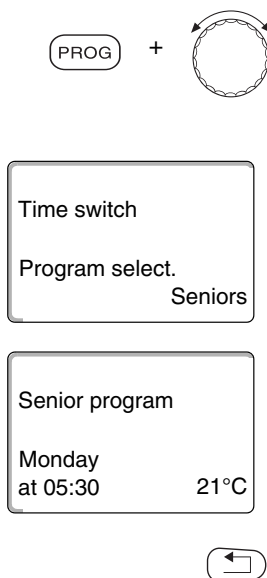

The display shows the program designation and the first switching point for the selected heating program (here "Senior program").

Press "Back" to return to the permanent display.



USER INFORMATION

Switching programs are only effective in automatic mode (→ Chapter 6.3.1).

7.11 Summary of standard programs

Program designation	Weekday	ON	OFF	ON	OFF	ON	OFF
"Family" (Factory setting)	Mo – Th Fr Sa Su	05:30 05:30 06:30 07:00	22:00 23:00 23:30 22:00				
"Early morning" Early shift	Mo – Th Fr Sa Su	04:30 04:30 06:30 07:00	22:00 23:00 23:30 22:00				
"Late evening" Late shift	Mo – Fr Sa Su	06:30 06:30 07:00	23:00 23:30 23:00				
"Morning" Part-time work in the morning	Mo – Th Fr Sa Su	05:30 05:30 06:30 07:00	08:30 08:30 23:30 22:00	12:00 12:00	22:00 23:00		
"Afternoon" Part-time work in the afternoon	Mo – Th Fr Sa Su	06:00 06:00 06:30 07:00	11:30 11:30 23:30 22:00	16:00 15:00	22:00 23:00		
"Noon" Noon at home	Mo – Th Fr Sa Su	06:00 06:00 06:00 07:00	08:00 08:00 23:00 22:00	11:30 11:30	13:00 23:00	17:00	22:00
"Single"	Mo – Th Fr Sa Su	06:00 06:00 07:00 08:00	08:00 08:00 23:30 22:00	16:00 15:00	22:00 23:00		
"Seniors"	Mo – Su	05:30	22:00				
"New"	You can enter your own individual program here:						
"Own 1"	If none of the standard programs suit you, you may alter them, have them changed by your heating contractor, or enter a new heating program (→ Chapter 8.2). This will be saved under "Own" and the number of the heating circuit.						

Tab. 1 Standard programs ("ON" = day mode, "OFF" = night mode)

7.12 Modifying the standard program by moving switching points

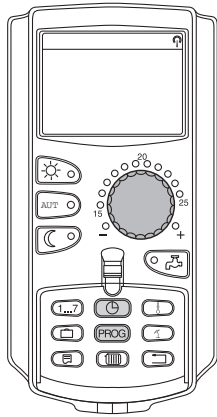

If the switching points, i.e. the times of a standard program at which the system changes over between day and night mode, only partially suit you, you may change them, or ask your local heating contractor to change them for you. The modified standard program is saved under "Own" and the number of the heating circuit. The heating program memory is available for this.

The following example shows how the switching points of the standard program "Family" can be changed for the days Monday to Thursday.

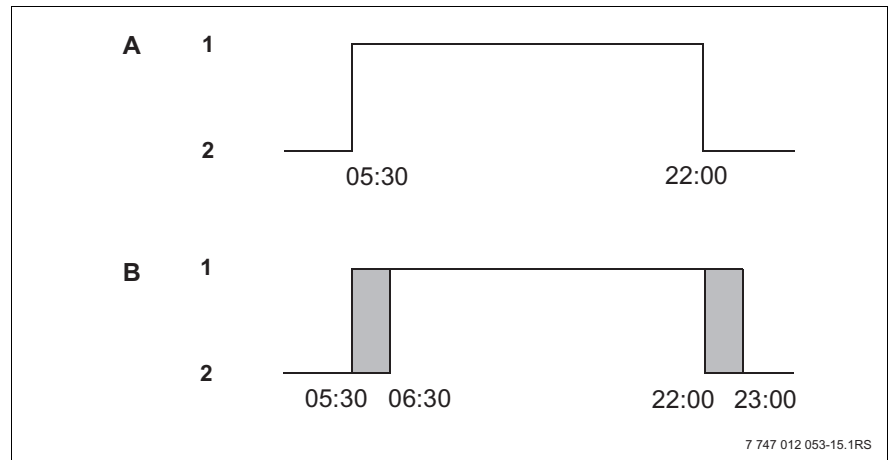

Fig. 13 Changing the switching points from 05:30 to 06:30 h and from 22:00 to 23:00 h (example)

A "Family program"

B New program "Own program 2"

1 Day mode

2 Night mode

- Open flap.
- Select a heating circuit (here: "Heating circ. 2", → Chapter 7.6).

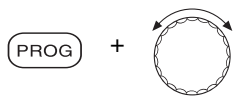

Hold down "PROG" and select the required standard program with the rotary selector.

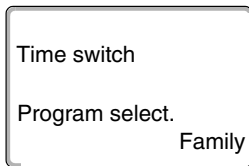

Release "PROG".

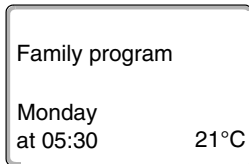

The first switching point (Monday, 05:30) appears.

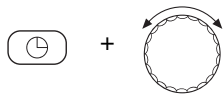

Hold down "Time", and select the required time with the rotary selector.
Example: "06:30".

Release "Time". The newly adjusted time for the "ON" switching point is now saved.

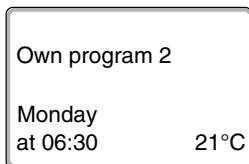

The modified switching point will be saved under the "Own" program and the number of the heating circuit (here "2").



Continue to turn the rotary selector, until the next switching point that you want to change is displayed.

The "OFF" switching point for Monday appears. Now you can modify the time for the "OFF" switching point.

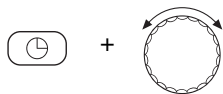

Hold down "Time", and select the required time with the rotary selector.
Example: "23:00".

Release "Time". The newly adjusted time for the "OFF" switching point is saved.

Next switching point



Continue to turn the rotary selector until the next switching point is displayed.

The next switching point (Tuesday, 05:30 h) appears.

Also change the following switching points to 06:30 and 23:00 h. The system will now heat from 06:30 h to 23:00 h Monday to Thursday.



Press "Back" to return to the permanent display.



USER INFORMATION

You can change the weekday if you press "Weekday" instead of "Time".

You can change the switching state ("ON"/"OFF") by pressing "Display" instead of "Weekday" or "Time". The operating mode determines the switching state: "ON" = day mode; "OFF" = night mode.

- Ensure that a stop point is associated with every start point.

The modified standard program is saved under "Own" and the number of the heating circuit.

7.13 Setting the summer/winter time changeover

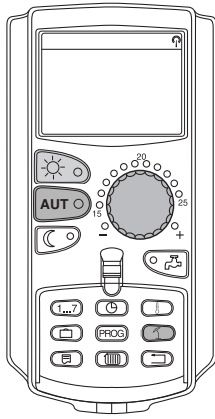

In addition to the outside temperature, your control unit considers the ability of the building to store heat and its thermal insulation (creating from these the "Adjusted outside temperature", → Fig. 14). After a delay, it automatically changes over between summer and winter mode.

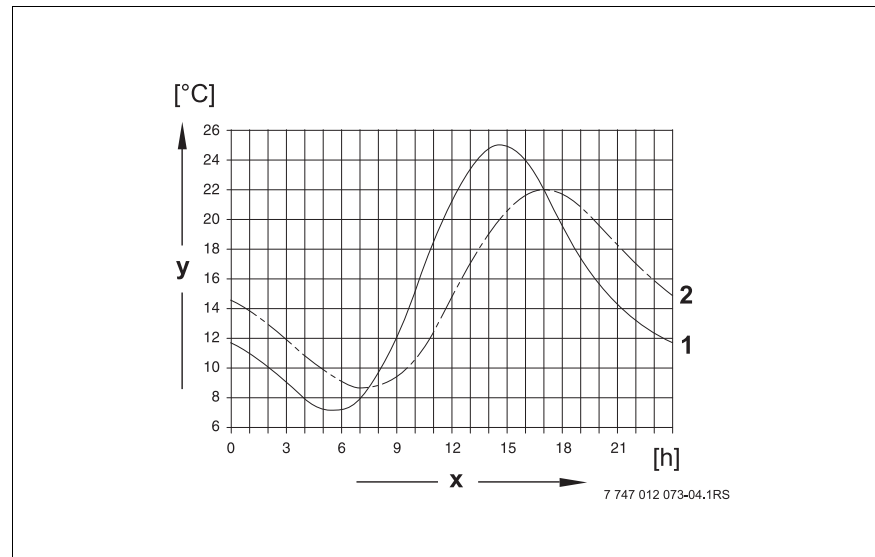

Fig. 14 Current and adjusted outside temperatures compared

- x** Outdoor temperature
- y** Time
- 1** Current outside temperature
- 2** Adjusted outside temperature

Summer mode

Heating operation is switched off if the "Adjusted outdoor temperature" exceeds the factory-set changeover threshold of 17 °C.

Summer mode is indicated on the display with symbol ☀.

DHW heating remains operational.

Press "Day mode" if you want to heat at short notice in summer mode.



The heating system returns to automatic summer mode if you press "AUT".

Winter mode

DHW and central heating are operational if the "Adjusted outside temperature" falls below the factory-set changeover threshold of 17 °C.

Setting the automatic summer/winter time changeover

Select the required heating circuit before calling up the summer/winter time changeover. You may select either an individual heating circuit or all circuits assigned to the MEC2.

- Select a heating circuit (→ Chapter 7.6).
Example: Heating circ. 2

Setting the changeover temperature

Hold down "Su/Wi". The display briefly shows the heating circuit. Then turn the rotary selector to the required changeover temperature, below which you want to heat (here: "18°C").

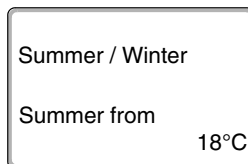
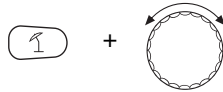

The display shows the set changeover temperature.

Release "Su/Wi" to save your input.

Setting up constant summer mode

- Select a heating circuit (→ Chapter 7.6).
Example: Heating circ. 2

Hold down "Su/Wi". The display briefly shows the heating circuit. Then turn the rotary selector to a changeover temperature below 10 °C.

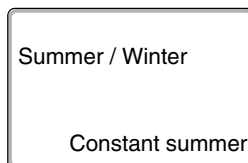
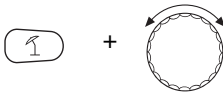

The display shows "Constant summer".

Release "Su/Wi" to save your input.

Your heating system will constantly operate in summer mode.

Setting up constant winter mode

- Select a heating circuit (→ Chapter 7.6).
Example: Heating circ. 2

Hold down "Su/Wi". The display briefly shows the heating circuit. Then turn the rotary selector to a changeover temperature above 30 °C.

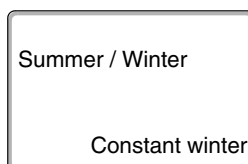
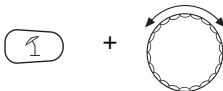

The display shows "Constant winter".

Release "Su/Wi" to save your input.

Your heating system will constantly operate in winter mode.

7.14 Setting the DHW operating mode

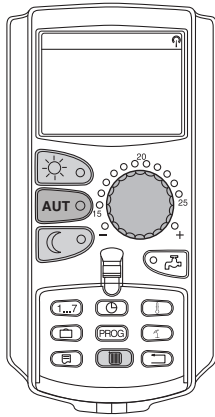

This allows you to change the DHW temperature in the DHW cylinder.

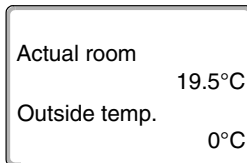
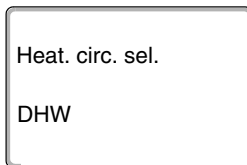
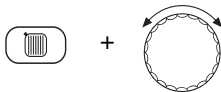

- Open flap.

Hold down "Heating circ." and select "DHW" with the rotary selector.

Release "Heating circuit".

The permanent display will then appear again.

Select one of the following operating modes for DHW:

- "Const. operation"
The water inside the DHW cylinder is constantly maintained at the set temperature.



Press "Day mode" to select constant operation. After approximately three seconds, the permanent display will appear again.

- "Automatic"
30 minutes before the first heating circuit is switched on, the DHW cylinder will heat the water to the set temperature, and stop when the last heating circuit is switched off (factory setting). Alternatively, you can enter your own DHW program (→ Chapter 8.3).



Press "Automatic" to select automatic mode. After approximately three seconds, the permanent display will appear again.

- "DHW circ. OFF"
DHW heating is switched off. By pressing "DHW", you will switch heating on for the duration of "DHW heating once".



Press "Night mode" to stop DHW heating. After approximately three seconds, the permanent display will appear again.

7.15 Setting the operating mode for DHW circulation

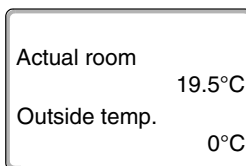
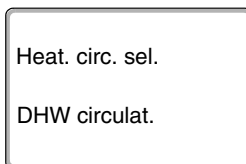
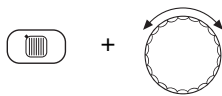
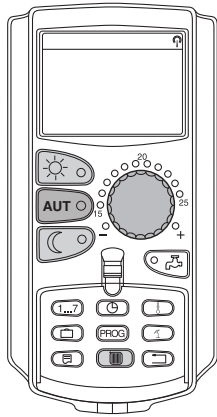

The DHW circulation pump provides an almost instantaneous supply of DHW to the draw-off points. For this, the DHW is circulated by a separate DHW circulation pump twice per hour for three minutes. Your heating contractor can match this interval to requirements at the service level.

You can modify the operating mode of DHW circulation as follows:

- Open flap.

Hold down "Heating circ." and select "DHW circulat." with the rotary selector.

Release "Heating circuit".

The permanent display will then appear again.

Select one of the following operating modes for the DHW circulation pump:

- "Constant operat."
The DHW circulation pump will operate at the set interval, i.e. independently of the heating circuits.

Press "Day mode" to select constant operation. After approximately three seconds, the permanent display will appear again.

- "Automatic"
30 minutes before the first heating circuit is started, the DHW circulation pump starts to run at the set interval, and stops when the last heating circuit is switched off (factory setting). Alternatively, you can enter your own DHW circulation pump program (→ Chapter 8.4).

Press "Automatic" to select automatic mode. After approximately three seconds, the permanent display will appear again.

- "DHW circulation OFF"
The DHW circulation pump will not be controlled. Pressing "DHW" switches the DHW circulation pump on for the duration of heating DHW once.

Press "Night mode" to switch off DHW circulation. After approximately three seconds, the permanent display will appear again.

7.16 Setting the holiday function

Using the holiday function, you can heat at a lower room temperature if you are away for a prolonged period.

Example:

If you are on holiday for the next five days and you want to heat less during that time, operate heating circuit 2 with a reduced room temperature of 12 °C, for example.



USER NOTE

As the holiday function is enabled immediately after completing your entry, you should only enter this function on the day of your departure.

- Select a heating circuit (→ Chapter 7.6).
Example: Heating circ. 2

Enter holiday function:

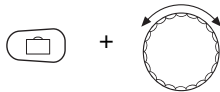
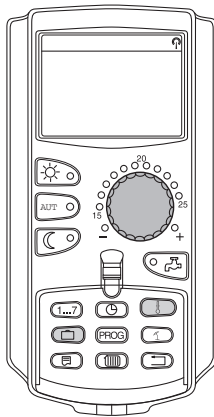

Hold "Holiday" down, and select the required number of days with the rotary selector (here: "5").

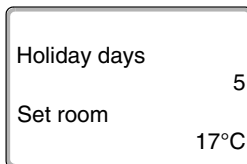

The display shows "5".

Release "Holiday" to save your input.



USER INFORMATION

The "Set room" display only appears if the "Hold room temp" holiday setback type or "Reduced" has been set by your heating contractor.

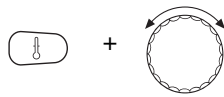

Hold "Temp" down, and select the required temperature with the rotary selector (here: "12°C").

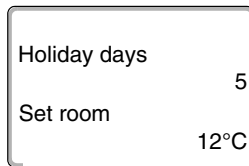

The display shows 12 °C.

Release "Temp" to save your input.

The holiday function is enabled immediately after entry.

You can cancel the holiday function any time by calling it up, as described above, and setting the number of holiday days to "0".



USER INFORMATION

DHW heating and DHW circulation will be switched off automatically if DHW is heated subject to the heating circuits ("Program select. by heat. circs", → Chapter 8.3), and all heating circuits are set to holiday mode. You cannot enter a separate DHW holiday function.



USER INFORMATION

A separate DHW holiday function can be entered if DHW is produced according to a separate time program ("Program selection own DHW", → Chapter 8.3). The DHW circulation pump is switched off automatically during the DHW holiday function.

7.17 Interrupting and continuing the holiday function

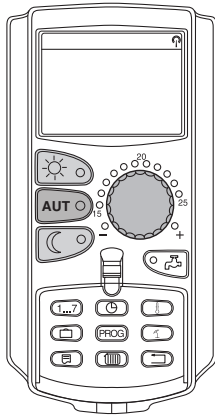

You may interrupt your holiday program at any time and provide heat according to the set day and night temperatures.

Only the "AUT" LED illuminates if a heating circuit is in holiday mode.

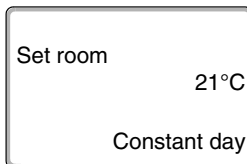

Interrupting the holiday function

Press "Day mode".

The display shows "Constant day".

You may interrupt the holiday function any time by pressing "Day mode". In this case the system heats according to the set room temperature (→ Chapter 6.4).



Continuing the holiday function

Press "AUT" to continue the interrupted holiday function.

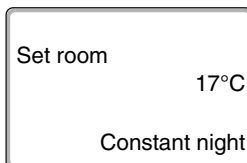

Interrupting the holiday function

Press "Night mode".

The display shows "Constant night".

You may interrupt the holiday function at any time by pressing "Night mode". In this case the system heats according to the set night temperature (→ Chapter 6.4).



Continuing the holiday function

Press "AUT" to continue the interrupted holiday function.

7.18 Setting the party function

This function only applies to heating circuits to which the MEC2 has been assigned as a remote control unit ("MEC heat. circ."). All heating circuits without an MEC2 continue to operate normally.

Enter the length of time the system should only heat to the preset room temperature.

Example:

You have a party and want to heat for the next four hours to the preset room temperature.

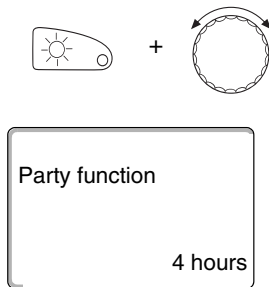

Hold down "Day mode", and **simultaneously open the flap of the MEC2**. "Party function" is enabled. Hold down "Day mode", and turn the rotary selector until the required number of hours is displayed (here: "4").

The display shows the party function together with the set number of hours.

Release "Day mode".

The party function starts immediately. After the set time has expired, the heating system returns to automatic heating mode.

If you want to cancel the party function, call up party function as described above and turn the rotary selector to "0".

7.19 Setting the pause function

This function only applies to heating circuits to which the MEC2 has been assigned as a remote control unit ("MEC heat. circ."). All heating circuits without an MEC2 continue to operate normally.

Enter the length of time the system should heat to the preset room temperature.

Example:

You are about to leave your home for three hours and would like to heat less whilst you are away.

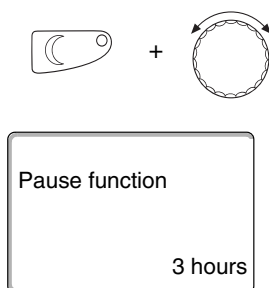

Hold down "Night mode", and **simultaneously open the flap of the MEC2**. The pause function is enabled. Continue to hold down "Night mode", and turn the rotary selector until the required number of hours is displayed (here: "3").

The display shows the pause function together with the set number of hours.

Release "Night mode".

The pause function starts immediately. After the set time has expired, the heating system returns to automatic heating mode.

If you want to cancel the pause function, call up pause function as described above and turn the rotary selector to "0".

7.20 Room temperature matching



USER INFORMATION

This function is only available if the MEC2 is fitted within the living space. If the room temperature shown on the display varies from the actual temperature measured with a thermometer, the display value can be adjusted using "Calibration MEC".

The factory setting is 0 °C. The possible correction range is between +5 °C and -5 °C.

Example:

Displayed room temperature 22 °C, actual room temperature 22.5 °C

- Open flap

Simultaneously press and then release "Display" and "Temp".

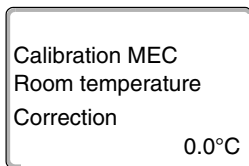

The display shows "Calibration MEC".

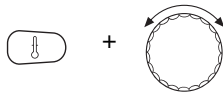

Hold down "Temp" and turn the rotary selector to the required value (here: "0.5°C").

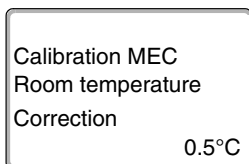

The display shows the set value.

Release "Temp" to save your input.



Press "Back" to return to the permanent display.

The display shows the corrected temperature (22.5 °C).

7.21 Automatic maintenance message

Note
maint. message



maint. after
Date
required

maint. after
Hours run
required

If your heating contractor has (with your agreement) enabled the "Automatic maintenance message", the maintenance message "Note maint. message" is displayed at the predetermined time.

- Open flap.

Turn the rotary selector.

You will see either "maint. after Date" or "maint. after Hours run".

- Notify your local heating contractor to schedule the inspection and maintenance work.

The Logamatic telecontrol system enables the maintenance message to be transmitted automatically to your mobile, PC or fax machine.



USER INFORMATION

The automatic maintenance message remains active until it is reset by your heating contractor.

8 Additional programming options

This chapter is intended to provide more detailed information to those of our customers who would like to familiarise themselves further with the functions of their heating system.

The following pages will explain how to change a standard program, if none of the preset standard programs (→ Chapter 7.11) match your lifestyle.

You will learn how to create a new heating program which accurately matches your personal circumstances.

8.1 Modifying the standard program by inserting/deleting switching points

8.1.1 Inserting switching points

You can interrupt heating phases by inserting switching points (details: Weekday/time/temperature) into an existing heating program.

Example:

The standard "Family" program provides constant heating on Fridays from 05:30 until 23:00 h. Insert two new switching points if, for example, you do not want to heat on Fridays from 10:00 to 13:00 h.

Your modified program will be saved under the program name "Own" and the number of the heating circuit.

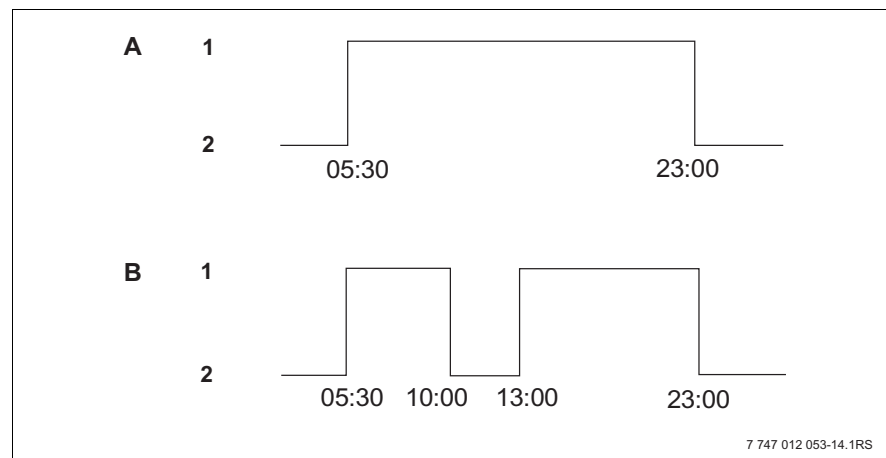
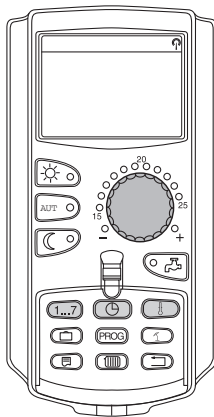
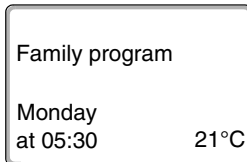

Fig. 15 Inserting switching points to interrupt a heating phase

- A "Family program"
- B New program "Own program 2"
- 1 Day mode
- 2 Night mode

- Select a heating circuit (→ Chapter 7.6).
Example: Heating circ. 2
- Select the standard program for the chosen heating circuit (→ Chapter 7.10).
(here: "Program select. family")

Release "Prog" to enable the selected standard program (here: "Family program").



The display shows the selected standard program.



Turn the rotary selector once anti-clockwise, until "New switch.point" is displayed.

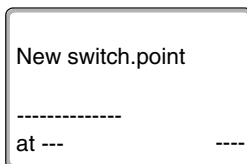

The display shows the blank screen "New switch.point" for the new switching point.

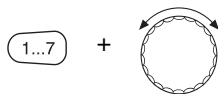

Hold down "Weekday" and turn the rotary selector to the required day (here: "Friday").

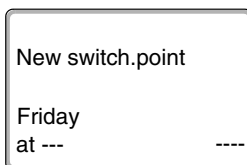

You can select days individually or in blocks:

- Monday – Thursday
- Monday – Friday
- Saturday – Sunday
- Monday – Sunday

Release "Weekday" to save your input.

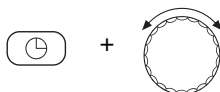

Hold "Time" down, and select the required time with the rotary selector (here: "10:00").

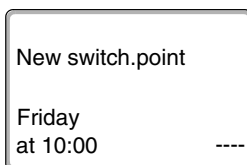

"Friday at 10:00" is now set as the new switching point.

Release "Time" to save your input.

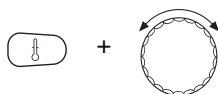

Hold "Temp" down, and select the required temperature with the rotary selector (here: "17°C").

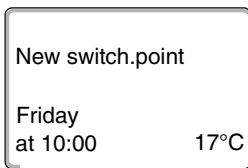

The display shows the set value.

Release "Temp" to save your input.



USER INFORMATION

You cannot freely enter any temperature here. Only the factory-set day and night temperatures are available, which you can, however, modify yourself (→ Chapter 6.4).



USER INFORMATION

Only after all three details (day/time/temperature) have been defined for the new switching point will it be automatically saved under "Own program" and the heating circuit number (here: "2"). This saving is not shown on the display. The display shows the blank screen "New switch.point" for the next switching point.

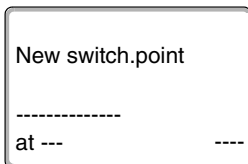

To enter the next switching point (e.g. "Friday, 13:00, 21 °C"), first repeat the procedure detailed above.



Press "Back" to return to the permanent display.

8.1.2 Deleting switching points

Example:

In the "Family program" for heating circuit 2, the switching point "Monday 22:00" is to be deleted.

Your modified program will be saved under the program name "Own" and the number of the heating circuit.

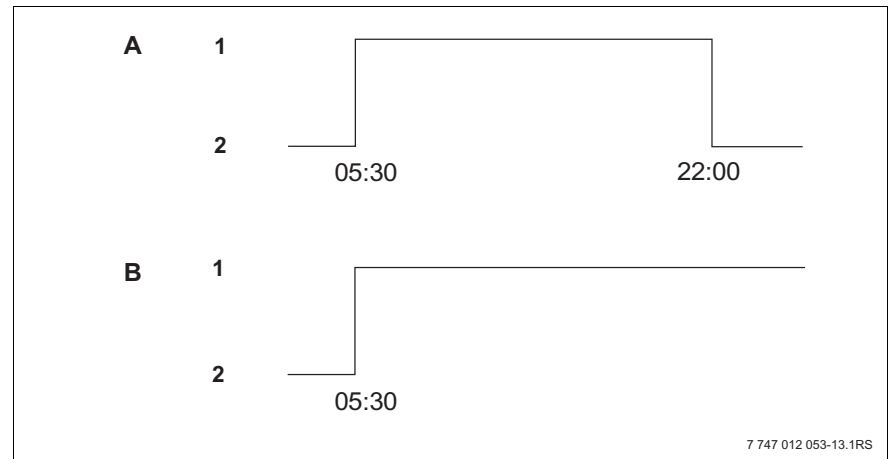
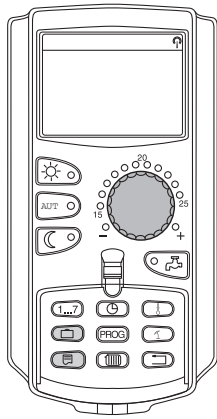

Fig. 16 Deleting a switching point

A "Family program"

B New program "Own program 2"

1 Day mode

2 Night mode

- Select a heating circuit (→ Chapter 7.6).
Example: Heating circ. 2
- Select the standard program for the chosen heating circuit (→ Chapter 7.10).
Example: Family program

The first switching point (start point): "Monday at 05:30" at "21°C" will be displayed.

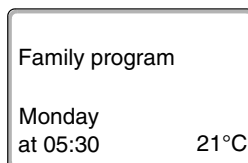



Turn the rotary selector to the switching point you want to delete (here: "22:00 h").

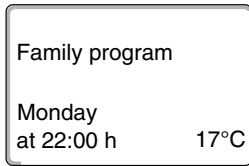

The switching point to be deleted is displayed.

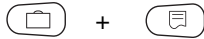

Simultaneously press and hold "Display" and "Holiday".

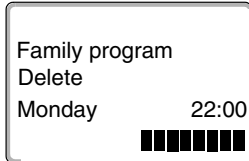

The bottom line shows eight blocks that are deleted in one-second intervals from left to right. The switching point has been deleted when no blocks are left.

The deleting process will be terminated if you release the keys prematurely.

Simultaneously release "Holiday" and "Display" to save your input.

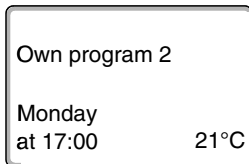

The display shows the next switching point.

The new program that has been modified by the deletion is saved under "Own program" and the relevant heating circuit number (here: "2").

You can call up your new program by pressing "Prog" and turning the rotary selector (→ Chapter 7.10).



Press "Back" to return to the permanent display.

8.1.3 Deleting a heating phase

A heating phase consists of two switching points - a start and a stop point. If you wish to delete a heating phase, both switching points must be deleted.

Example:

In the "Midday program" for heating circuit 2, you want to delete the Monday heating phase from 11:30 h to 13:00 h to create one single heating pause from 08:00 h to 17:00 h.

Your modified program will be saved under the program name "Own" and the number of the heating circuit.

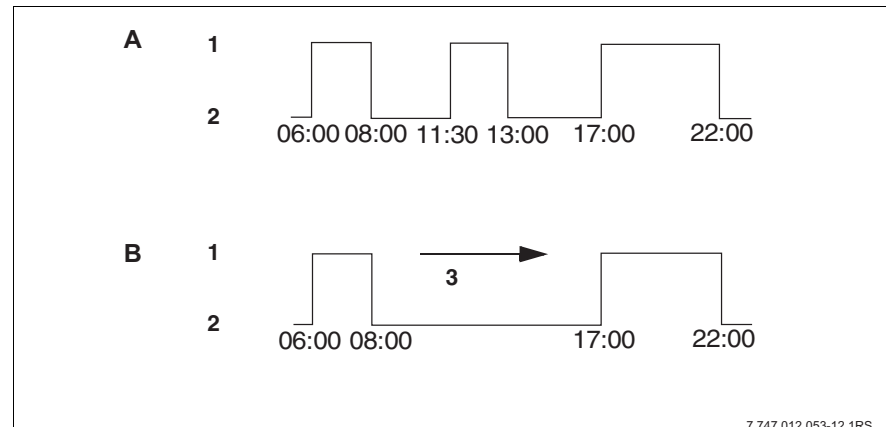
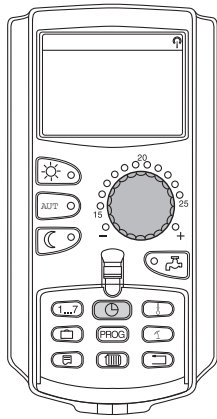

7 747 012 053-12.1RS

Fig. 17 Deleting a heating phase

A "Midday program"

B New program "Own program 2"

- 1 Day mode
- 2 Night mode
- 3 Delete

- Select a heating circuit (→ Chapter 7.6).

Example: Heating circ. 2

- Select the standard program for the chosen heating circuit (→ Chapter 7.10).

Example: "Midday program"

The first switching point (start point): "Monday at 06:00" at "21°C" will be displayed. The displayed temperature depends on the set room temperature.

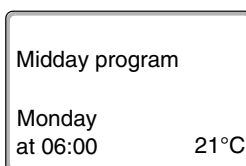



Turn the rotary selector to the start point of the heating phase you want to delete (here: "11:30").

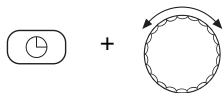
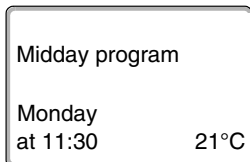

Hold down "Time" and turn the rotary selector to the stop point of the heating phase you want to delete (here: "13:00").



If you have selected the stop switching point of the heating phase you want to delete, the bottom line will show eight blocks that are deleted in one-second intervals from left to right. The heating phase has been deleted when no blocks are left.

The deleting process will be terminated if you release the "Time" key prematurely or turn the rotary selector back. In this case all switching points for the heating phase remain active.

Release "Time" to save your input.

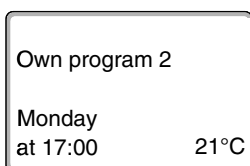

The display shows the next switching point.

The new program that has been modified by the deletion is saved under "Own program" and the relevant heating circuit number (here: "2").

You can call up your new program by pressing "Prog" and turning the rotary selector (→ Chapter 7.10).



Press "Back" to return to the permanent display.

8.1.4 Connecting heating phases

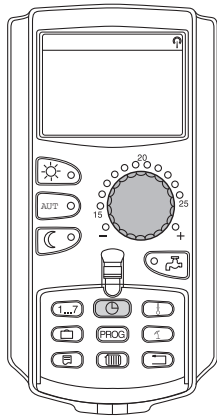

A heating phase consists of two switching points - a start and a stop point. To connect two consecutive heating phases, place the stop point of the first heating phase onto the start point of the next phase.

Example:

Starting from the "Midday program" for heating circuit 2, you want to join the Monday heating phase from 11:30 h to 13:00 h to the heating phase 17:00 h to 22:00 h. In other words you want to heat continually from 11:30 until 22:00 h.

Your modified program will be saved under the program name "Own" and the number of the heating circuit.

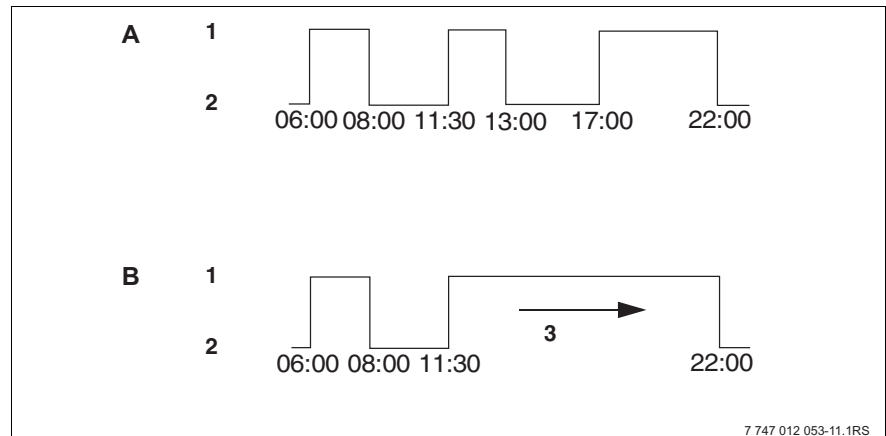

Fig. 18 Connecting two heating phases

A "Midday program"

B New program "Own program 2"

1 Day mode

2 Night mode

3 Turn from 13:00 to 17:00

- Select a heating circuit (→ Chapter 7.6).
Example: Heating circ. 2
- Select the standard program for the chosen heating circuit (→ Chapter 7.10).
(here: "Midday program")

The first switching point (start point): "Monday at 06:00" at "21°C" will be displayed.

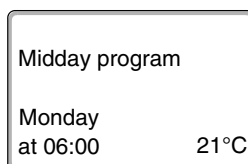

Turn the rotary selector to the stop point of the first heating phase you want to connect with another (here: "13:00").

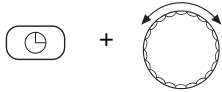
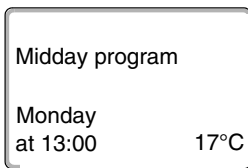

The display shows the stop point to be connected.

Hold down "Time" and turn the rotary selector clockwise, until the start point of the second heating phase, i.e. the next consecutive heating phase, is displayed, which you wish to combine with the first heating phase (here: "17:00").

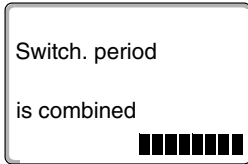

If you have selected the start point of the next consecutive heating phase, the bottom line will show eight blocks, which are deleted in one-second intervals from left to right. When no blocks are left both heating phases have been combined.

The deleting process will be terminated if you release the "Time" key prematurely or turn the rotary selector back. In this case all switching points for the heating phase remain active.



Release "Time" to save your input.

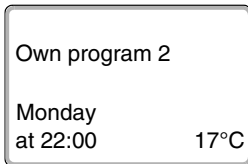

The new program that has been modified by the connection process is saved under "Own program" and the heating circuit number (here: "2").

You can call up your new program by pressing "Prog" and turning the rotary selector (→ Chapter 7.10).

Press "Back" to return to the permanent display.

8.2 Creating a new heating program

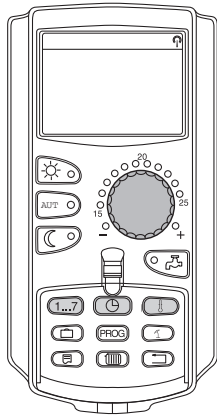

You may enter up to 42 switching points per week and heating circuit to create a new heating program. A single switching point comprises three details: Weekday, time and temperature.

The newly created program will be saved under "Own program" and the relevant heating circuit number.

Example:

Monday – Friday,
from 05:00 h 21 °C, from 21:00 h 17 °C

Saturday – Sunday,
from 09:30 h 21 °C, from 23:30 h 17 °C

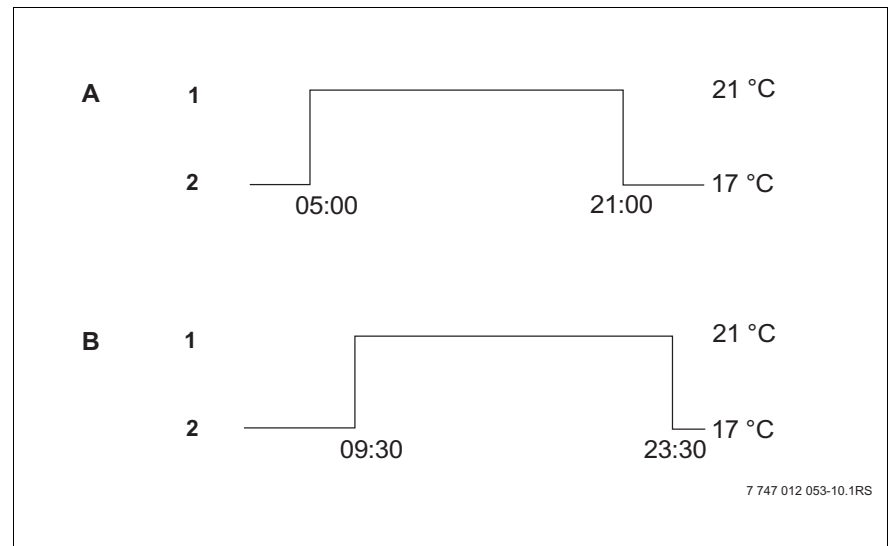

Fig. 19 New heating program

A New heating program "Own program 2"
Monday – Friday

B Saturday – Sunday

1 Day mode

2 Night mode

- Select a heating circuit (→ Chapter 7.6).
Example: Heating circ. 2
- Select the standard program "Program select. new" for this heating circuit (→ Chapter 7.10).

The display shows the blank screen "New switch.point".

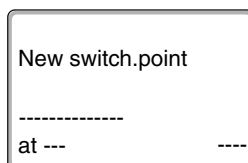

Enter the first switching point (Monday – Friday, 05:00 h, 21 °C)

You can select days individually or in blocks:

- Monday – Thursday
- Monday – Friday
- Saturday – Sunday
- Monday – Sunday

Hold down "Weekday" and select the required day or block with the rotary selector (here: "Monday-Friday").

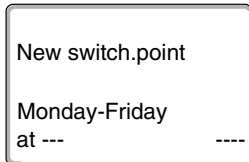
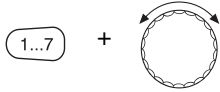

Release "Weekday" to save your input.

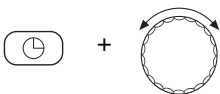

Hold "Time" down, and select the required time with the rotary selector (here: "05:00").

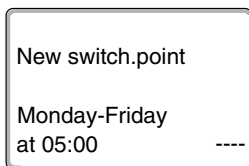

The display shows the new switching point.

Release "Time" to save your input.

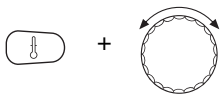

Hold "Temp" down, and select the required temperature with the rotary selector (here: "21°C").

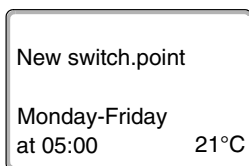

You cannot freely enter any temperature here. Only the factory-set day and night temperatures are available, which you can, however, modify yourself (→ Chapter 6.4).



Release "Temp" to save your input.

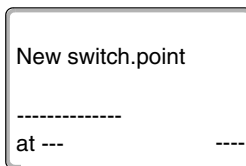

Only after all three details (day/time/temperature) have been set for the new switching point will it be automatically saved under "Own program" and the heating circuit number (here: "2"). This saving is not shown on the display. The display shows the blank screen "New switch.point" for the next switching point.

- Enter the second switching point (Monday – Friday, 21:00 h, 17 °C).
- Enter the third switching point (Saturday – Sunday, 09:30 h, 21 °C).
- Enter the fourth switching point (Saturday – Sunday, 23:30 h, 17 °C).

To enter the second to fourth switching points, you only need to repeat the steps described above.



Press "Back" to return to the permanent display only after all switching points have been correctly entered.

Your heating program will now operate according to your "Own program". You can call up your new "Own program" by pressing "Prog" and turning the rotary selector.

8.3 Creating a new DHW program

You may operate DHW heating either according to the factory settings "Program select. by heat. circs" or according to your own switching program "Program select. own DHW".



USER INFORMATION

With the factory setting "Program select. by heat. circs", DHW heating begins 30 minutes prior to the first switching point of all heating circuits associated with this control unit, and ends when the last heating circuit is switched off.

If DHW is to be heated independently of the heating circuits, you can enter your own new DHW program as follows:

Example:

On all weekdays DHW should be heated from 06:30 h until 09:00 h.

- Select a heating circuit (→ Chapter 7.6).
(here: "DHW")
- Select a program for the heating circuit "DHW" (→ Chapter 7.10).
(here: "Program select. new")

The display shows the blank screen "New switch.point" for the new switching point.

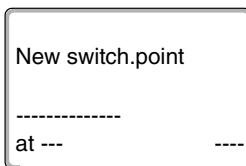

- Enter the switching points (→ Chapter 8.2).



USER INFORMATION

Only after all three details (day/time/temperature) have been defined for the new switching point will it be automatically saved under "Own program DHW", and the heating circuit selection "DHW". This saving is not shown on the display. The display shows the blank screen "New switch.point" for the next switching point. Repeat this process for all required switching points.

DHW heating will now operate according to your "Own program DHW". You can call up your new "Own program DHW" by pressing "Prog" and turning the rotary selector (→ Chapter 7.6).

8.4 Creating a new DHW circulation pump program

You can operate the DHW circulation pump either according to the factory settings "Program select. by heat. circs" or according to your own new switching program "Program select. own CP".



USER INFORMATION

With the factory setting "Program select. by heat circs", the DHW circulation pump will automatically start 30 minutes before the first switching point of all heating circuits associated with this control unit, and end when the last heating circuit is stopped.

If your circulation pump should work independently of the heating circuits, you can enter your own new DHW circulation pump program as follows:

Example:

The DHW circulation pump is to run on all weekdays from 06:30 to 09:00 h.

- Select a heating circuit (→ Chapter 7.6).
(here: "DHW circulat.")
- Select a program for the heating circuit "DHW circulat." (→ Chapter 7.10).
(here: "Program select. new")

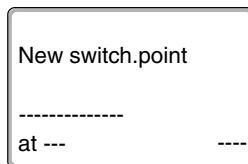

The display shows the blank screen "New switch.point" for the new switching point.

- Enter the switching points (→ Chapter 8.2).



USER INFORMATION

Only after all three details (day/time/temperature) have been defined for the new switching point will it be automatically saved under "Own program CP" and the heating circuit number "DHW circulat.". This saving is not shown on the display. The display shows the blank screen "New switch.point" for the next switching point. Repeat this process for all required switching points.

Your DHW circulation pump will now operate according to your "Own program CP". You can call up your new "Own program CP" by pressing "Prog" and turning the rotary selector.

8.5 Thermal disinfection



WARNING!

RISK OF SCALDING

from hot water in the DHW circuit of the heating system if it is not equipped with a thermostatic mixer.

- During and shortly after thermal disinfection, do not open any hot water tap without mixing in some cold water as well.

If "Therm. disinfect" has been selected for your heating system, the DHW is brought to a temperature once or several times a week that is high enough, for example, to kill off legionella bacteria.

The cylinder primary pump and DHW circulation pump (if installed) run constantly during thermal disinfection.

Thermal disinfection is started according to the times set at the factory. If required, your heating contractor can alter these settings.

Thermal disinfection is indicated by the LED display  on the FM441 and FM445 modules.

9 Modules and their functions

The following lists all the modules that are or can be fitted in Logamatic 412x control units.

Module		Logamatic		
		4121	4122	4126
	MEC2 programming unit	O	●	O
	ZM435 boiler display	X	●	X
	CM431 controller module	O	O	O
	ZM424 central module 2 heating circuits + 1 DHW circuit	O	–	–
	FM441 function module 1 heating circuit + 1 DHW circuit	–	X	–
	FM442 function module 2 heating circuits	X	X	X
	FM443 function module Solar circuit	X	X	X
	FM444 function module Alternative heat source	X	X	X
	FM445 function module LAP/LSP (primary system)	X	X	O
	FM446 function module EIB interface	X	X	X
	FM448 function module Central fault message	X	X	X
	FM455 function module KSE 1 (only with ZM424)	O	–	–
	FM456 function module KSE 2 (cascade - 2 boilers)	X	X	X
	FM457 function module KSE 4 (cascade - 4 boilers)	X	X	X
	FM458 function module Strategy module	–	–	–

Tab. 2 Modules and their functions

- O = Standard equipment level
- = Subject to version, either an MEC2 programming unit or a ZM435 boiler display may be fitted as standard equipment.
- X = Accessories
- = Combination/installation not possible

The following pages contain information regarding the most important modules you can use.

Particularly the modules FM443, FM444, FM446, FM448, FM456, FM457 and FM458 are described separately in the technical module documentation.

9.1 ZM424 central module

The ZM424 module together with the FM455 module are part of the standard equipment of the **Logamatic 4121** control unit.

The ZM424 module must always be installed in the l.h. slot 1. The FM455 module must always be installed below the ZM424 in slot A.

The switches on the module only have service and maintenance functions and only affect the 230 V outputs.

If the switches are not set to automatic, a message to this effect appears on the MEC2 programming unit and fault indicator  lights up.



USER INFORMATION

Never use the switches to shut down the heating system during temporary absence.

Use the holiday function for this purpose (→ chapter Chapter 7.16).

The control functions remain operational in manual mode.

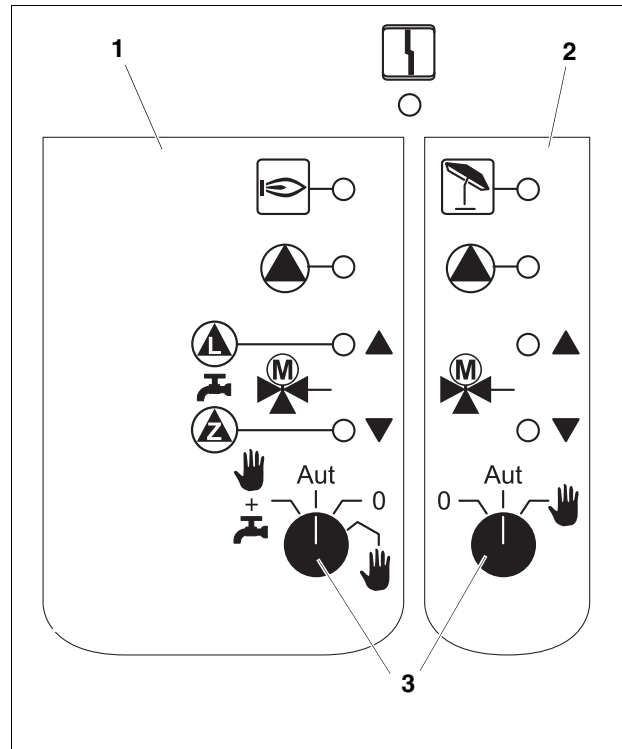









Fig. 20 ZM424

- 1 Boiler, heating circuit 1, DHW
- 2 Heating circ. 2
- 3 Switch

Display  General fault, e.g. on-site faults, sensor faults, external faults, wiring faults, internal module faults, manual mode. The fault messages appear as plain text on the MEC2 programming unit.

LEDs for the following functions:

- Display  Burner operational
- Display  "Mixer opens" (hotter)
- Display  "Mixer closes" (colder)
- Display  Heating circuit 2 in summer mode
- Display  Heating circuit pump operational
- Display  Cylinder primary pump operational
- Display  DHW circulation pump operational

Heating circuit and DHW function

Switch heating circuit and DHW

for heating circ. 1:

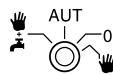

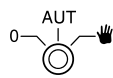

for heating circ. 2:



USER INFORMATION

In standard mode, set the switch to "AUT".

The positions **0** and **manual** (hand icon) are special settings reserved for heating contractors only.

-  : The heating circuit pump is switched on.
The mixer is switched to zero volt and can be manually operated.
- AUT: The central heating or DHW circuit operates in automatic mode.
- 0: The heating circuit pump and possibly the cylinder primary pump as well as the DHW circulation pump are stopped.
The mixer is switched to zero volt. The control functions continue to operate.
-  + : The heating circuit and cylinder primary pumps start when "4000 cylinder" has been selected in the "DHW" menu (→ service instructions).

LEDs indicate the current function status.

9.2 FM441 function module (accessory)

The FM441 module regulates one heating circuit and one DHW heating facility.

The switches on the module only have service and maintenance functions and only affect 230 V outputs.

Only fit this module in the control unit once.

If the switches are not set to automatic, a corresponding message appears on the MEC2 programming unit, and the  fault indicator illuminates.



USER INFORMATION

Never use the switches to shut down the heating system during temporary absence.

Use the holiday function for this purpose (→ operating instructions for Logamatic 412x control unit).

The control functions remain operational in manual mode.

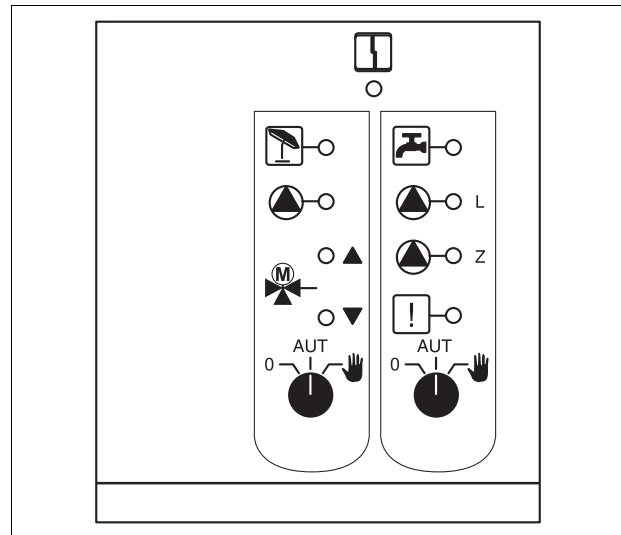

Fig. 21 FM441

Display



General fault, e.g. on-site faults, sensor faults, external faults, wiring faults, internal module faults, manual mode. Fault messages appear as plain text on the MEC2 programming unit.

LEDs for the following functions:

Display		"Mixer opens" (hotter)
Display		"Mixer closes" (colder)
Display		Heating circuit in summer mode
Display		DHW in night mode below the set temperature.
Display		Heating circuit pump operational
Display	- L	Cylinder primary pump operational
Display	- Z	DHW circulation pump operational
Display		Thermal disinfection enabled

Heating circuit and DHW function

Heating circuit switch (→ Fig. 22, [1]) and DHW (→ Fig. 22, [2]).

for heating circ. 1:



for DHW supply:



USER INFORMATION

In standard mode, the switches should be set to "AUT".

The positions **0** and (manual mode) are special settings reserved for heating contractors only.

- : The heating circuit pump or primary pump is switched on.
The mixer is switched to zero volt and can be manually operated.
The DHW circulation pump is switched off.
- AUT**: The heating circuit or DHW circuit operates in automatic mode.
- 0**: The heating circuit pump or cylinder primary pump as well as the DHW circulation pump are switched off.
The mixer is switched to zero volt. The control functions remain active.

Current functions are indicated by LEDs.

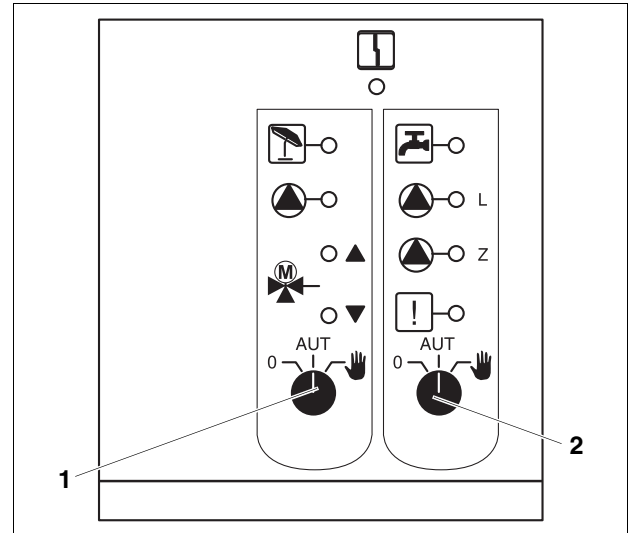



Fig. 22 FM441

- 1** Heating circuit switch
- 2** DHW switch

9.3 FM442 function module (accessory)

The FM442 module regulates two independent heating circuits with mixer. Several of these modules can be used in one control unit.

The switches on the module only have service and maintenance functions and only affect 230 V outputs.

If the switches are not set to automatic, a corresponding message appears on the MEC2 programming unit, and the fault indicator  illuminates.



USER INFORMATION

Never use the switches to shut down the heating system during temporary absence.

Use the holiday function for this purpose (→ operating instructions for Logamatic 412x control unit).

The control functions remain operational in manual mode.

Heating circuit function

Heating circuit switch

e.g. for heating circuits 1 and 2



USER INFORMATION

In standard mode, the switches should be set to "AUT".

The positions **0** and  (manual mode) are special settings reserved for heating contractors only.

 : The heating circuit pump is switched on. The mixer is switched volt-free and can be manually operated.

AUT: The heating circuit operates in automatic mode.

0: The heating circuit pump is switched off. The mixer is switched volt-free. The control functions remain active.

Current functions are indicated by LEDs.

The switches on the modules only have service and maintenance functions, and affect only the 230 V outputs.

If the switches are not set to automatic, a message to this effect appears on the MEC2 programming unit and fault indicator  illuminates.

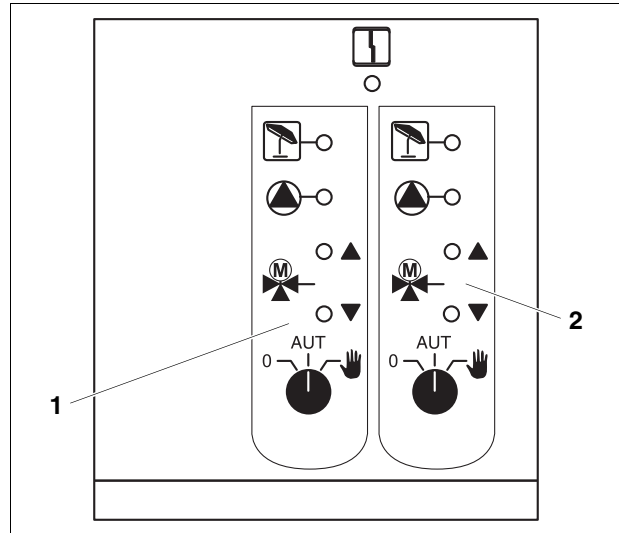



Fig. 23 FM442

1 Heating circuit x

2 Heating circuit y

Display  General fault, e.g. on-site faults, sensor faults, external faults, wiring faults, internal module faults, manual mode. Fault messages appear as plain text on the MEC2 programming unit.

LEDs for the following functions:

Display  "Mixer opens" (hotter)

Display  "Mixer closes" (colder)

Display  Heating circuit in summer mode

Display  Heating circuit pump operational

9.4 FM445 function module (Logamatic 4126)

The FM445 module controls DHW heating via a primary system.

Plug it into the r.h. slot (slot 2) of the control unit; this ensures the power supply to all other modules. Only use this module if no other FM441 has already been installed in the control unit.

The switches on the module are for service and maintenance purposes and only affect the 230 V outputs.

If the switches are not set to automatic, a message to this effect appears on the MEC2 programming unit and fault indicator  illuminates.



USER INFORMATION

Never use the switches to shut down the heating system during temporary absence.

Use the holiday function for this purpose (→ chapter Chapter 7.16).

The control functions remain operational in manual mode.

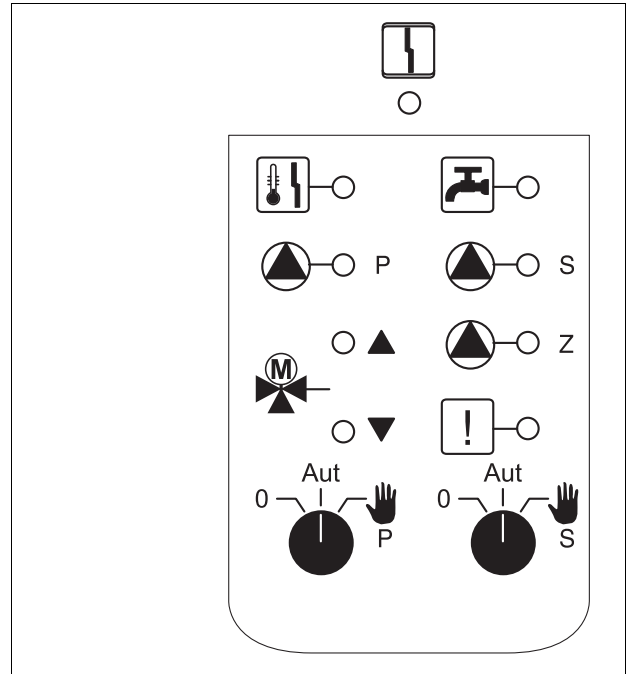











Fig. 24 FM445

Display  General fault, e.g. on-site faults, sensor faults, external faults, wiring faults, internal module faults, manual mode. The fault messages appear as plain text on the MEC2 programming unit.

LEDs for the following functions:

- Display  DHW is/remains below the set temperature in setback (night) mode
- Display  "Mixer opens" (hotter)
- Display  "Mixer closes" (colder)
- Display  - P Cylinder primary pump operational
- Display  - S Cylinder secondary pump operational
- Display  - Z DHW circulation pump operational
- Display  Thermal disinfection
- Display  Anti-scaling protection enabled, secondary pump cycles

DHW function

DHW switch

for primary circuit:

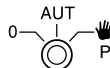

for secondary circuit:

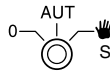
**USER INFORMATION**

In standard mode, set the switch to "AUT".

**RISK OF SCALDING****WARNING!**

In manual mode you are at risk from scalding.

- Always open the cold water tap and mix with hot water according to requirements.

The positions **0** and **manual** (👉) are special settings reserved for heating contractors only.

- 👉 : The secondary/primary pump is switched on. The mixer is switched to zero volt and can be manually operated.
- AUT: The DHW primary system operates in automatic mode.
- 0: The primary and secondary pumps and the DHW circulation pump are switched off. The mixer is switched to zero volt. The control functions continue to operate.

LEDs indicate the current functions.

10 Boiler flue gas test



WARNING!

RISK OF SCALDING

During the flue gas test, the water can reach a temperature in excess of 60 °C. This creates a risk of scalding at the draw-off points.

- Only draw off mixed hot and cold water during or just after a flue gas test. Note that when mono-lever mixer taps are in their usual position, the water drawn may be too hot.
- Never draw off hot water only when using twin-lever mixer taps.



USER INFORMATION

Observe the relevant national requirements regarding limiting the flue gas losses of your heating system.

- Arrange an annual flue gas test.
- The flue gas test is started at the boiler (see technical boiler documentation).

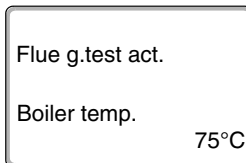

During the flue gas test the MEC2 will show the display on the left.

11 Troubleshooting

Have your heating contractor remedy any faults immediately.

All system faults are displayed on the MEC2 programming unit.

Report the fault by telephone to your heating contractor. Where necessary, set the module switches according to the instructions in (→ Chapter 12).

Provided your control unit is equipped with the above modules, the following faults may be reported:

– Boiler	Outside temperature sensor	– DHW	Inert anode
– Heating circuit x	Flow sensor	– DHW	Ext. fault input
– DHW	DHW sensor	– Heating circuit x	In manual mode
– DHW	stays cold	– DHW	In manual mode
– DHW	Therm. disinfect	– DHW	Primary pump in manual mode
– DHW	EMS	– DHW	Secondary pump in manual mode
– DHW	DHW warning	– DHW	HE sensor
– Heating circuit x	Remote control	– DHW	Sensor OFF
– Heating circuit x	Communication	– DHW	Sensor ON
– Heating circuit x	Heating circuit X in manual mode	– Boiler (x)	No connection
– Boiler x	Status y burner	– Low loss header	Flow sensor
– Heating circuit x	Fault mess. pump	– Boiler x	Three-way valve
– BUS system	ECO BUS has no reception	– Solar	Cylinder X in manual mode
– BUS system	No master		
– BUS system	Address conflict		
– Address	Conflict slot 1		
– Address	Conflict slot 2		
– Address	Conflict slot A		
– Address	Incorrect module slot 1		
– Address	Incorrect module slot 2		
– Address	Incorrect module slot A		
– Address	Unknown module slot 1		
– Address	Unknown module slot 2		
– Address	Unknown module slot A		

11.1 Simple troubleshooting

If no fault messages are displayed on the control unit in spite of cool rooms or cool DHW, there may be an incorrect setting.

Observation	Possible cause(s)	Measure
Control unit remains blank or does not function	<ul style="list-style-type: none"> - ON/OFF switch set to "OFF". - No power supply. 	<ul style="list-style-type: none"> - ON/OFF switch set to "ON". - Check mains electrical fuse. - Heating system emergency stop switch set to "ON".
MEC2 display dark	<ul style="list-style-type: none"> - MEC2 incorrectly plugged in (contact problems). 	<ul style="list-style-type: none"> - Fit MEC2 correctly.
Room cool	<ul style="list-style-type: none"> - Actual room temperature for the respective heating circuit is incorrectly displayed. 	<ul style="list-style-type: none"> - Check the heating circuit assignment.
	<ul style="list-style-type: none"> - Control unit operates in setback mode. 	<ul style="list-style-type: none"> - Check time and heating program, and modify if required.
	<ul style="list-style-type: none"> - Set room temperature is too low. 	<ul style="list-style-type: none"> - Correct the set room temperature.
	<ul style="list-style-type: none"> - DHW supply runs for too long. 	<ul style="list-style-type: none"> - Check DHW heating.
	<ul style="list-style-type: none"> - Heat sources deliver insufficient heating energy or are shut down. 	<ul style="list-style-type: none"> - Check heat sources.
DHW cool	<ul style="list-style-type: none"> - Room temperature sensor is incorrectly adjusted. 	<ul style="list-style-type: none"> - Sensor adjustment.
	<ul style="list-style-type: none"> - DHW is set to the wrong temperature. 	<ul style="list-style-type: none"> - Correct the DHW temperature setting.
	<ul style="list-style-type: none"> - Switching program is incorrectly set up. 	<ul style="list-style-type: none"> - Re-program the switching program.

Tab. 3 Simple troubleshooting

11.2 Troubleshooting

Fault	Effect	Remedy
DHW stays cold (in case of DHW heating via Logamatic 4000).	DHW is too cold.	Set DHW switch on module ZM424, FM441 or FM445 to manual mode. Notify your local heating contractor.
DHW stays cold (in case of DHW heating via Logamatic EMS).	DHW is too cold.	Notify your local heating contractor.
Remote control fault	The programming unit works with the last values set on the MEC2 programming unit.	Notify your local heating contractor.
External sensor fault Flow sensor fault	The heating system may heat with higher temperatures to safeguard the heat supply.	Notify your local heating contractor. Tell your heating contractor which temperature sensor is faulty.
Flow sensor fault	It may get too hot.	Manually adjust the mixer. Notify your local heating contractor.
Low loss header flow sensor fault	Possible over or under flow.	Notify your local heating contractor.
Heating circuit x communication fault	No communication between one BFU and the control unit.	Remote control may be faulty. Notify your local heating contractor.
Boiler 1 status y burner fault	It goes cold.	Try and remedy the boiler fault (→ see technical boiler documentation).
DHW sensor fault (DHW heating via Logamatic 4000)	If the DHW sensor is faulty, water will not be heated for safety reasons.	Notify your local heating contractor.
DHW sensor HE fault Sensor ON fault sensor OFF fault (in case of DHW heating via FM445)	If the DHW sensor is faulty, water will not be heated for safety reasons.	Notify your local heating contractor.
Heating circuit x in manual mode	Depending on switch positions, pumps, servomotors/actuators, etc. will be operated manually.	The switches were set to manual (for maintenance purposes or to remedy a fault). Return the switches to "AUT" after the fault has been removed.
Boiler x in manual mode	No automatic function, such as heating program.	This is not a fault. Turn the rotary selectors on the BC10 base controller to "AUT" if manual mode is no longer required.
Boiler x No connection fault	It goes cold.	Switch the boiler to manual. Notify your local heating contractor.

Tab. 4 Troubleshooting

12 Operation in the event of a fault



RISK TO LIFE

from electric shock.

WARNING!

- Never open the control unit.
- In an emergency, switch off the control unit (e.g. with the heating system emergency stop switch) or isolate the heating system from the mains supply by removing the main fuse.
- Arrange for your local heating contractor to rectify any heating system faults immediately.



CAUTION!

SYSTEM DAMAGE

If an underfloor heating system is installed: Before operating your heating system manually, check the temperature settings of the temperature limiter on the boiler. If the temperature is set incorrectly, the underfloor heating system could overheat.

Switches are provided for manual mode on the control unit and the modules.

In position  the relevant pump is started. The mixers remain volt-free and can be manually adjusted.

12.1 Emergency mode

If the electronics fail, the control unit can operate in emergency mode. In emergency mode, all pumps continue to run and the mixers are volt-free. Mixers can be manually set. In such cases, notify your local heating contractor.

12.2 Manual mode Logamatic 4121

Before making any adjustments for manual mode, check the individual modules for any settings which may be incorrect. If the control system indicates a fault you may temporarily run your heating system manually.



WARNING!

RISK OF SCALDING

The DHW temperature can be set to a maximum of 80 °C. Settings higher than 60 °C create a risk of scalding at the draw-off points.

- Ask your local heating contractor about the maximum set DHW temperature and/or check it yourself. The DHW temperature is set via the thermostat of the wall mounted boiler.



CAUTION!

SYSTEM DAMAGE

through closed mixer circuits.

- To ensure operational reliability, mixer circuits must not be fully closed.

- Switch on the control unit via the ON/OFF switch (→ Fig. 25, [1]).
- Set heating circuit 1 (poss. + DHW) (→ Fig. 25, [3]) at selector switch to manual or .
- Set heating circuit (→ Fig. 25, [2]) at selector switch to manual .
- Set boiler water thermostat on the boiler to the required temperature.
- Switch on "Flue gas test" switch on the wall mounted boiler.

In case of faults, immediately notify your local heating contractor, who will provide a professional service. Notify your contractor of the faults displayed on the MEC, or the fault code on the boiler.

Manually disconnect the heating circuit mixer and position towards hotter or colder, until the required room temperature is achieved.

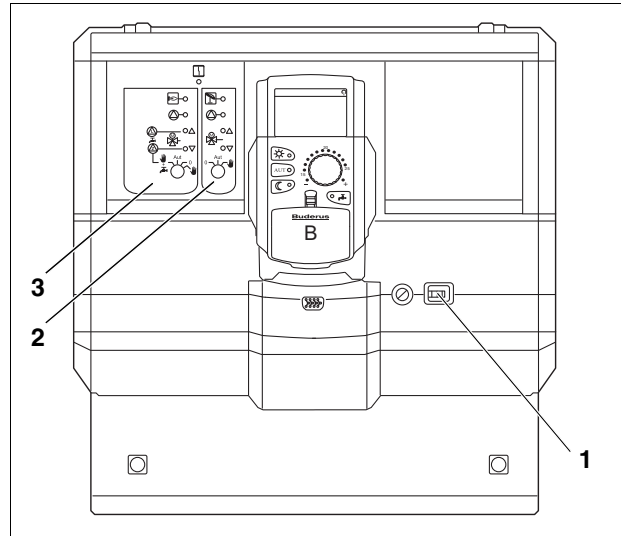

Fig. 25 Logamatic 4121

12.3 Manual mode Logamatic 4126

Before making any adjustments for manual mode, check the individual modules for any settings which may be incorrect. If the control system indicates a fault you may temporarily run your heating system manually.



RISK OF SCALDING

from hot water!

WARNING!

The DHW temperature can be set to a maximum of 80 °C. Settings higher than 60 °C create a risk of scalding at the draw-off points.

- Ask your local heating contractor about the maximum set DHW temperature and/or check it yourself. The DHW temperature is set via the thermostat of the wall mounted boiler.







SYSTEM DAMAGE

through closed mixer circuits!

CAUTION!

- To ensure operational reliability, mixer circuits must not be fully closed.

- Switch on the control unit via the ON/OFF switch (→ Fig. 26, [1]).
- Set primary circuit (→ Fig. 26, [2]) at selector switch  to manual .
- Set secondary circuit (→ Fig. 26, [3]) at selector switch  to manual .
- Set boiler water thermostat on the boiler to the required temperature.
- Switch on "Flue gas test" switch  on the wall mounted boiler.

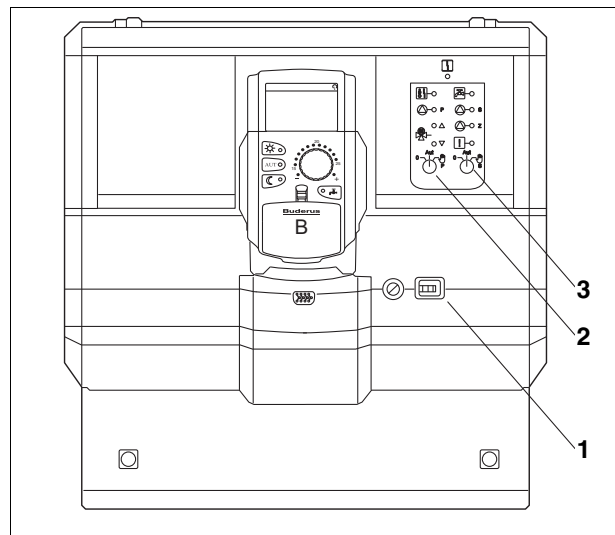

Fig. 26 Logamatic 4126

13 Setup report

Operating values	Input range	Factory settings	Setting
Program selection	Family Early morning Late evening Morning Afternoon Noon Single Seniors New	Family	
DHW	30 °C – 60 °C	60 °C	
Summer/winter time changeover	10 °C – 30 °C Constant summer Constant winter	17 °C	
Day room temperature	11 °C – 30 °C	21 °C	
Night room temperature	2 °C – 29 °C	17 °C	
Holiday room temperature	10 °C – 30 °C	17 °C	
Thermal disinfection	Yes/No	No	

Assignment of heating circuits

As part of the commissioning process, your heating contractor will assign the individual heating circuits of your heating system, e.g. heating circuit 1 = "l.h. side of ground floor".

Heating circ.	Assignment
Heating circ. 0	
Heating circ. 1	
Heating circ. 2	
Heating circ. 3	
Heating circ. 4	
Heating circ. 5	
Heating circ. 6	
Heating circ. 7	
Heating circ. 8	

14 Keyword index

A

Adjusted outside temperature	44
Automatic	53
Automatic mode	20, 21

B

Boiler5
------------------	----

D

Day mode9, 20
DHW circulation pump	47
DHW cylinder5
DHW function	71, 76
DHW heating	25
DHW temperature	26
Displayed faults	78

E

Emergency mode	81
Emergency stop switch	17

F

Factory settings	66, 84
DHW heating	25
Fault message "Setting not possible"	36
Fault message "Time switch not possible"	36
Fault messages	79
Faults	78
Fitted modules	14
Flow sensor	80
Flue gas test	77
FM441 function module	72
FM442 function module	74
FM445	75

H

Heating circuit	33, 34, 72
Heating circuit function	71, 73
Heating circuits - assignment	84
Heating control unit5
Heating phase	59
Heating program	28, 37, 39
Holiday function	48, 50
Holiday program	48

I

Instantaneous water heater5
--------------------------------------	----

K

Keypad	15
------------------	----

L

LEDs	72, 74
----------------	--------

M

Manual mode	20, 22, 80
-----------------------	------------

N

Night mode9, 20
----------------------	--------

O

Operating mode	
Automatic	21
Day	22
Manual	20, 22
Night	22
Operating values	29, 84

P

Permanent display	19, 30
Pipework5

R

Radiator5
Radio receiver	31
Room temperature	
matching	52
setting the required	18, 23

S

Setting the date	32
Setting the time	32
Setting up summer mode	45
Setting up winter mode	45
Setup report	84
Standard equipment	70
Standard program	39
Switching point	41

T

Thermal disinfection	68
Thermometer	52
Thermostatic radiator valves6
Thermostatic valve6
Time switch	31, 37
Troubleshooting	80

U

Underfloor heating system	81
-------------------------------------	----

Z

ZM424	70
-----------------	----

Buderus
Cotswold Way, Warndon, Worcester WR4 9SW
Customer service: 0870 421 5933
Technical support: 0870 421 5944
Fax: 01905 753130
www.buderus.co.uk

C & F Quadrant Ltd.
Unit L40 Cherry Orchard Industrial Estate
Cherry Orchard, Dublin 10
Tel.: 01.6305700
Fax.: 01.6305706 / 01.6305715
www.cfquadrant.ie
E-mail: sales@cfquadrant.ie

In the UK and IE, Buderus is a brand name of
Bosch Thermotechnology Ltd.

Bosch Thermotechnik GmbH
Sophienstrasse 30-32
D-35576 Wetzlar
www.buderus.de
info@buderus.de

Buderus