

# Sirius three WH

Installation operation and maintenance manual

Wall Hung Stainless Steel Condensing Boilers

130 - 150 kW



Working towards  
a cleaner future

**POTTERTON**  
COMMERCIAL

Dear Customer,  
 Thank you for your purchase. Our company is confident that your new product will meet all of your requirements. Purchasing this product gives you a solution that provides peace of mind, ease of use and exceptional performance. Please ensure that you read this manual before installing the product as it contains vital information for its correct use. Failure to install the product as advised in this manual may result in void of the warranty terms and conditions.

Our company declares that these products are marked **CE** in compliance with the essential requirements of the following Directives:

- Gas regulation (EU) **2016/426**
- Efficiency Directive **92/42/EEC**
- Electromagnetic Compatibility Directive **2014/30/EU**
- Low Voltage Directive **2014/35/EU**
- Ecodesign directive **2009/125/EC**
- Regulation (EU) No **2017/1369** (for boilers with Power<70kW)
- Ecodesign regulation (EU) No **813/2013**
- Energy labelling regulation (EU) No **811/2013** (for boilers with Power<70kW)

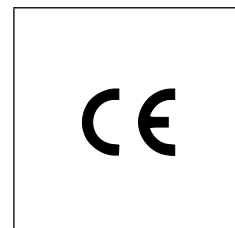

Our company, constantly striving to improve the products, reserves the right to modify the details given in this documentation at any time and without notice. These Instructions are only meant to provide consumers with use information and under no circumstance should they be construed as a contract with a third party.

**The appliance can be used by children aged 8 or over and by people with reduced physical, sensory or mental faculties, or who do not have the required experience or knowledge, provided they are supervised or have received instructions on using the appliance safely and understanding its intrinsic hazards. Children must not play with the appliance. The cleaning and maintenance operations reserved to the user must not be performed by unsupervised children.**

## CONTENT

DESCRIPTION OF SYMBOLS .....	3
SAFETY WARNINGS.....	3
GENERAL PRECAUTIONS .....	4
1. TECHNICAL SPECIFICATIONS.....	5
1.1 TECHNICAL PARAMETERS .....	6
1.2 PRODUCT FICHE.....	7
2. INSTALLING THE BOILER.....	8
3. INSTALLING THE FLUES.....	12
4. CONCENTRIC FLUES.....	12
5. CASCADE FLUES .....	14
6. GAS LINE PRESSURE DROP.....	14
7. BOILER PUMP.....	15
8. PUMP CAPACITY/ HEAD .....	16
9. ELECTRICAL CONNECTIONS.....	16
9.1 INSTALLING THE CONTROL PANEL ON THE WALL .....	18
9.2 OUTDOOR SENSOR.....	19
10. ACCESSORIES NOT INCLUDED IN THE PACKAGING .....	21
10.1 WIRING OF BOILER PUMP .....	21
10.2 HEATING SYSTEM PUMP .....	21
10.3 DOMESTIC HOT WATER CYLINDER.....	21
10.4 MIXED ZONES (SEE CHAP. "DIAGRAMS").....	21
10.5 OUTDOOR SYSTEM MANAGEMENT MODULES.....	21
10.6 BOILERS IN A CASCADE CONNECTION (SEE CHAP. "DIAGRAMS").....	21
10.7 AGU 2.550 .....	21
10.8 CONNECTING THE ROOM THERMOSTAT.....	22
11. COMMISSIONING THE BOILER.....	22
CONTROL PANEL .....	22
11.1 BASIC CONTROL PANEL SETTINGS.....	23
12. FILLING THE SYSTEM.....	23
13. SYSTEM AIR EXTRACTION FUNCTION .....	23
14. GAS VALVE COMMISSIONING.....	23
14.1 GAS CONVERSION .....	24
15. SPECIAL FUNCTIONS .....	24
16. TEMPERATURE ADJUSTMENT .....	25
17. OPERATING MODES .....	25
17.1 HEATING.....	25
17.2 HOLIDAY PROGRAMME .....	25
18. HOURLY PROGRAMMING.....	26
18.1 GROUPS OF DAYS .....	26
18.2 SINGLE DAYS.....	26
18.3 HOURLY PROGRAMMING EDIT PROCEDURE (HEATING / DHW) .....	26
18.4 CONTROL PANEL BLOCK FUNCTION .....	27
19. SWITCHING OFF THE BOILER .....	27
20. PROLONGED SHUTDOWN / FROST PROTECTION .....	27
ENERGY-SAVING TIPS.....	28
21. ACCESS TO THE PARAMETER CONFIGURATION MENUS .....	28
21.1 INFORMATION MENU .....	28
21.2 TIME AND DATE MENU .....	28
21.3 CHANGE LANGUAGE (OPERATOR UNIT MENU).....	29
22. FUNCTIONS ASSOCIATED WITH THE EASY MENU BUTTON (RAPID MENU  ).....	29

23.	FAULTS .....	29
23.1	RESETTING FAULTS .....	30
24.	FAULTS THAT CANNOT BE RESET BY THE USER .....	30
25.	ADJUSTMENT AND SAFETY DEVICES .....	31
26.	ROUTINE MAINTENANCE INSTRUCTIONS .....	31
27.	ANNUAL SERVICING .....	32
27.1	CLEANING THE HEAT EXCHANGER FUMES SIDE .....	32
27.2	CHECKING THE BURNER .....	33
	POSITIONING THE ELECTRODES .....	33
27.3	CLEANING THE CONDESATE TRAP .....	33
27.4	COMBUSTION PARAMETERS .....	33
28.	THERMAL FUSE REPLACEMENT OF HEAT EXCHANGER .....	34
29.	DISMANTLING, DISPOSAL AND RECYCLING .....	34
30.	DIAGRAMS .....	35

## DESCRIPTION OF SYMBOLS



### WARNING

Risk of damage to or malfunction of the appliance. Pay special attention to the warnings concerning danger to people.



### DANGER OF BURNS

Wait for the appliance to cool down before working on the parts exposed to heat.



### DANGER - HIGH VOLTAGE

Live components - electrocution hazard.



### DANGER OF FREEZING

Possible formation of ice due to low temperatures.



### IMPORTANT INFORMATION







Information to read with particular care as it is useful for the correct operation of the boiler.



### GENERIC PROHIBITION

It is forbidden to do/use the things indicated alongside the symbol.

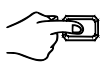
#### SYMBOLS ON THE CONTROL PANEL (section 9.1.1 - 11)

	Turn knob <b>B</b>		Display shows
	Press knob <b>B</b>		Press button <b>A</b> and knob <b>B</b> together
	Press button <b>A</b> or <b>C</b>		Press buttons <b>A</b> and <b>C</b> together

## SAFETY WARNINGS

### SMELL OF GAS

- Switch off the boiler.
- Do not activate any electrical device (such as switching on the light).
- Put out any naked flames and open the windows.
- Call an Authorised Service Engineer.

### SMELL OF COMBUSTION FUMES

- Switch off the boiler.
- Open all the doors and windows to ventilate the room.
- Call an Authorised Service Engineer.

### FLAMMABLE MATERIAL

Do not use and/or store highly flammable material (thinners, paper, etc.) near the boiler.

## SERVICING AND CLEANING THE BOILER

Switch off the boiler before working on it.



The appliance is not intended to be used by persons with reduced physical, sensory or mental capacities, or who lack experience or knowledge, unless, through the mediation of a person responsible for their safety, they have had the benefit of supervision or of instructions on the use of the appliance.

## GENERAL PRECAUTIONS

This boiler has been designed to heat water to a temperature lower than boiling point at atmospheric pressure. It must be connected to a central heating system and to a domestic hot water supply system according to its performance and power output. Before having the boiler installed by a qualified service engineer, make sure the following operations are performed:

- Make sure that the boiler is adjusted to use the type of gas delivered by the gas supply. To do this, check the markings on the packaging and the data label on the appliance.
- Make sure that the flue terminal draft is appropriate, that the terminal is not obstructed and that no exhaust gases from other appliances are expelled through the same flue duct, unless the latter has been specially designed to collect exhaust gas from more than one appliance, in compliance with current laws and regulations.
- Make sure that, if the boiler is connected to existing flue ducts, these have been thoroughly cleaned as residual products of combustion may detach from the walls during operation and obstruct the flow of fumes.
- To ensure correct operation and maintain the warranty, observe the following precautions:

### 1. DHW circuit

**1.1** If the water is harder than 20 °F (1 °F = 10 mg calcium carbonate per litre of water), install a polyphosphate dispenser or an equivalent treatment system, compliant with current regulations.

**1.2** Thoroughly flush the system after installation of the appliance and before use.

**1.3** The materials used for the DHW circuit comply with Directive 98/83/EC.

### 2. Heating circuit

**2.1 New system:** Before installing the boiler, the system must be cleaned and flushed to eliminate residual thread-cutting swarf, solder and any solvents, using suitable off-the-shelf non-acid and non-alkaline products that do not damage metal, plastic and rubber parts. To protect the system from scale, use inhibitors such as SENTINEL X100 and FERNOX protector for heating circuits. Use these products in strict compliance with the manufacturers' instructions.

**2.2 Existing system:** Before installing the boiler, drain the system and clean it to remove sludge and contaminants, using suitable proprietary products. Recommended cleaning products are: SENTINEL X300 or X400 and FERNOX regenerator for heating circuits. Use these products in strict compliance with the manufacturers' instructions. Remember that the presence of foreign bodies in the heating system can adversely affect boiler operation (e.g. overheating and excessive noise of the heat exchanger).

Initial lighting of the boiler must be carried out by an authorised Service Engineer who must first ensure that:

- The rated data correspond to the supply (electricity, water and gas) data.
- That the installation complies with current regulations.
- The appliance is correctly connected to the power supply and earthed.



**The appliance must be installed in a ventilated boiler room pursuant to current regulations (appliances with heating capacity > 40 kW).**





**Failure to observe the above will render the warranty null and void. Prior to commissioning, remove the protective plastic coating from the boiler. Do not use any tools or abrasive detergents to do this as you may damage the painted surfaces.**



**Do not leave any packaging (plastic bags, polystyrene, etc.) within the reach of children as they are a potential source of danger.**

# 1. TECHNICAL SPECIFICATIONS

Model: SIRIUS THREE		WH-130	WH-150
Category		II <sub>2</sub> H3P	
Gas used Natural Gas and LPG	-	G20 - G31	
Rated heat input	kW	123,8	143,0
Reduced heat input (G20)	kW	24,8	28,6
Reduced heat input (G31)	kW	35,4	40,9
Rated heat output 80/60 °C	kW	121,5	140,3
Rated heat output 50/30 °C	kW	130,6	150,9
Reduced heat output 80/60 °C (G20)	kW	24,3	28,1
Reduced heat output 80/60 °C (G31)	kW	34,7	40,0
Reduced heat output 50/30 °C (G20)	kW	26,2	30,2
Reduced heat output 50/30 °C (G31)	kW	37,3	43,1
Net Rated efficiency 50/30 °C	%	105,5	105,5
Max. pressure of water in heating circuit	bar	6	
Min. pressure of water in heating circuit	bar	1	
Capacity of boiler circuit (volume of water)	l	10	11
Temperature range in heating circuit	°C	25÷80	
Flue Types	-	C13 - C33 - B23	
Concentric flue duct diameter	mm	110/160	
Diameter of separate outlets	mm	110/110	
Max. mass flow rate of flue (G20)	kg/s	0,056	0,064
Min. mass flow rate of flue (G20)	kg/s	0,012	0,014
Max. temperature of fumes	°C	70	
NOx Class	-	6	
Natural gas supply pressure 2H (G20)	mbar	17÷25	
Propane gas supply pressure 3P (G31)	mbar	27÷45	
Power supply voltage	V	230	
Power supply frequency	Hz	50	
Rated power supply (Without Pump)	 W	187	283
Rated power supply (With Pump)	 W	360	460
Net weight (empty)	kg	93	96
Dimensions	- height	mm 952	
	- width	mm 600	
	- depth	mm 584	
Protection-limit against humidity (EN 60529)	-	IPX5D	
CE Certificate	Nr	0085CM0128	

## CONSUMPTION AT HEAT INPUT Q<sub>max</sub> and Q<sub>min</sub>

Q <sub>max</sub> (G20) - 2H	m <sup>3</sup> /h	13,09	15,12
Q <sub>min</sub> (G20) - 2H	m <sup>3</sup> /h	2,62	3,02
Q <sub>max</sub> (G31) - 3P	kg/h	9,62	11,11
Q <sub>min</sub> (G31) - 3P	kg/h	1,93	2,22

## 1.1 TECHNICAL PARAMETERS

POTTERTON COMMERCIAL			SIRIUS THREE WH-130	SIRIUS THREE WH-150
Condensing boiler			Yes	Yes
Low-temperature boiler <sup>(1)</sup>			No	No
B1 boiler			No	No
Cogeneration space heater			No	No
Combination heater			No	No
<b>Rated heat output</b>	$P_{rated}$	kW	122	140
Useful heat output at rated heat output and high temperature regime <sup>(2)</sup>	$P_4$	kW	121.5	140.3
Useful heat output at 30% of rated heat output and low temperature regime <sup>(1)</sup>	$P_1$	kW	40.4	46.6
<b>Seasonal space heating energy efficiency</b>	$\eta_s$	%		
Useful efficiency at rated heat output and high temperature regime <sup>(2)</sup>	$\eta_4$	%	88.4	88.4
Useful efficiency at 30% of rated heat output and low temperature regime <sup>(1)</sup>	$\eta_1$	%	97.8	97.8
<b>Auxiliary electricity consumption</b>				
Full load	$el_{max}$	kW	0.187	0.283
Part load	$el_{min}$	kW	0.051	0.052
Standby mode	$P_{SB}$	kW	0.003	0.003
<b>Other items</b>				
Standby heat loss	$P_{stby}$	kW	0.097	0.097
Ignition burner power consumption	$P_{ign}$	kW	0.000	0.000
Annual energy consumption	$Q_{HE}$	GJ		
Sound power level, indoors	$L_{WA}$	dB	60	64
Emissions of nitrogen oxides	NO <sub>x</sub>	mg/kWh	17	23
<b>Domestic hot water parameters</b>				
<b>Declared load profile</b>				
Daily electricity consumption	$Q_{elec}$	kWh		
Annual electricity consumption	$AEC$	kWh		
<b>Water heating energy efficiency</b>	$\eta_{wh}$	%		
Daily fuel consumption	$Q_{fuel}$	kWh		
Annual fuel consumption	$AFC$	GJ		
<p>(1) Low temperature means for condensing boilers 30°C, for low temperature boilers 37°C and for other heaters 50°C return temperature (at heater inlet).</p> <p>(2) High temperature regime means 60°C return temperature at heater inlet and 80°C feed temperature at heater outlet.</p>				

## 1.2 PRODUCT FICHE

POTTERTON COMMERCIAL		SIRIUS THREE WH-130	SIRIUS THREE WH-150
Space heating - Temperature application		Medium	Medium
Water heating - Declared load profile			
Seasonal space heating energy efficiency class			
Water heating energy efficiency class			
Rated heat output ( <i>Prated or Psup</i> )	kW	122	140
Space heating - Annual energy consumption	GJ		
Water heating - Annual energy consumption	kWh <sup>(1)</sup> GJ <sup>(2)</sup>		
Seasonal space heating energy efficiency	%		
Water heating energy efficiency	%		
Sound power level L <sub>WA</sub> indoors	dB	60	64
(1) Electricity (2) Fuel			

## 2. INSTALLING THE BOILER



After fixing the boiler on the wall, replace the cap at the bottom of the siphon with the one in the pack, reusing the ring nut and referring to the figure. Fill the siphon and check it for any leaks.

The template outline is shown in chap. "INSTALLING THE BOILER".

After deciding the exact location of the boiler, fix the template to the wall. Connect the system to the gas and water inlets present on the lower bar of the template. Make sure the rear part of the boiler (back) is as parallel as possible to the wall (otherwise, shim the lower part). Fit two G1" 1/2 taps (flow and return) on the central heating circuit; these taps make it possible to carry out important operations on the system without draining it completely. The hydraulic system must comply with BS6644 in respect to pressure relief valve rating, size and location. Fit a hydraulic separator, sized according to maximum boiler and system pressure, downline from the hydraulic connectors of the boiler. If you are either installing the boiler on an existing system or replacing one, as well as the above, fit a settling tank under the boiler on the system return line in order to collect any deposits and scale circulating in the system after flushing. After fixing the boiler to the template, connect the flue and air ducts, supplied as accessories, as described in the following sections. Connect the siphon to a drain trap, making sure the slope is continuous. Avoid horizontal stretches. The boiler is electronically fitted out to manage an external storage boiler.



**Take special care when filling the heating system. In particular, open any thermostat valves in the system, ensure the water enters slowly in order to prevent the formation of air inside the primary circuit until operating pressure is reached. Lastly, vent any radiators in the system. POTTERTON COMMERCIAL declines all liability for damage deriving from the presence of air bubbles in the primary exchanger due to the incorrect or imprecise observance of the above.**

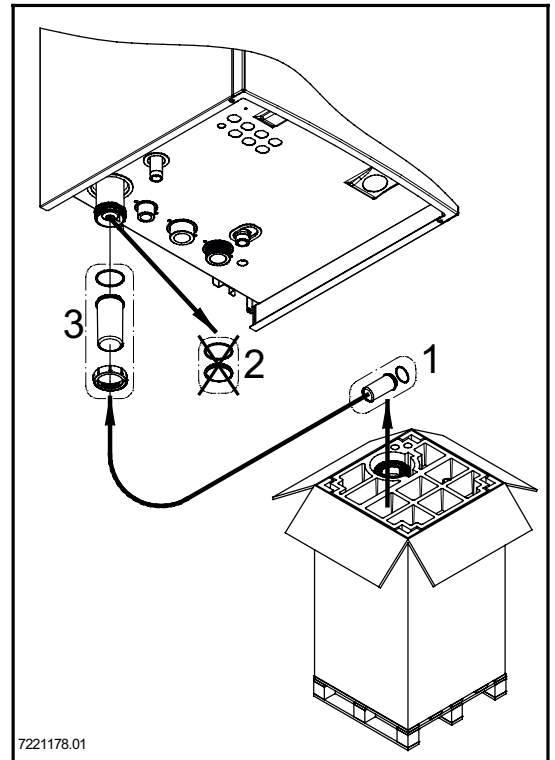

Tighten the boiler water connections with care (maximum tightening torque 30 Nm).



Do not lift the boiler exerting pressure on the plastic parts like the siphon and the flue turret.



Before starting up the boiler, fill the water siphon to prevent the fumes from diffusing in the room.



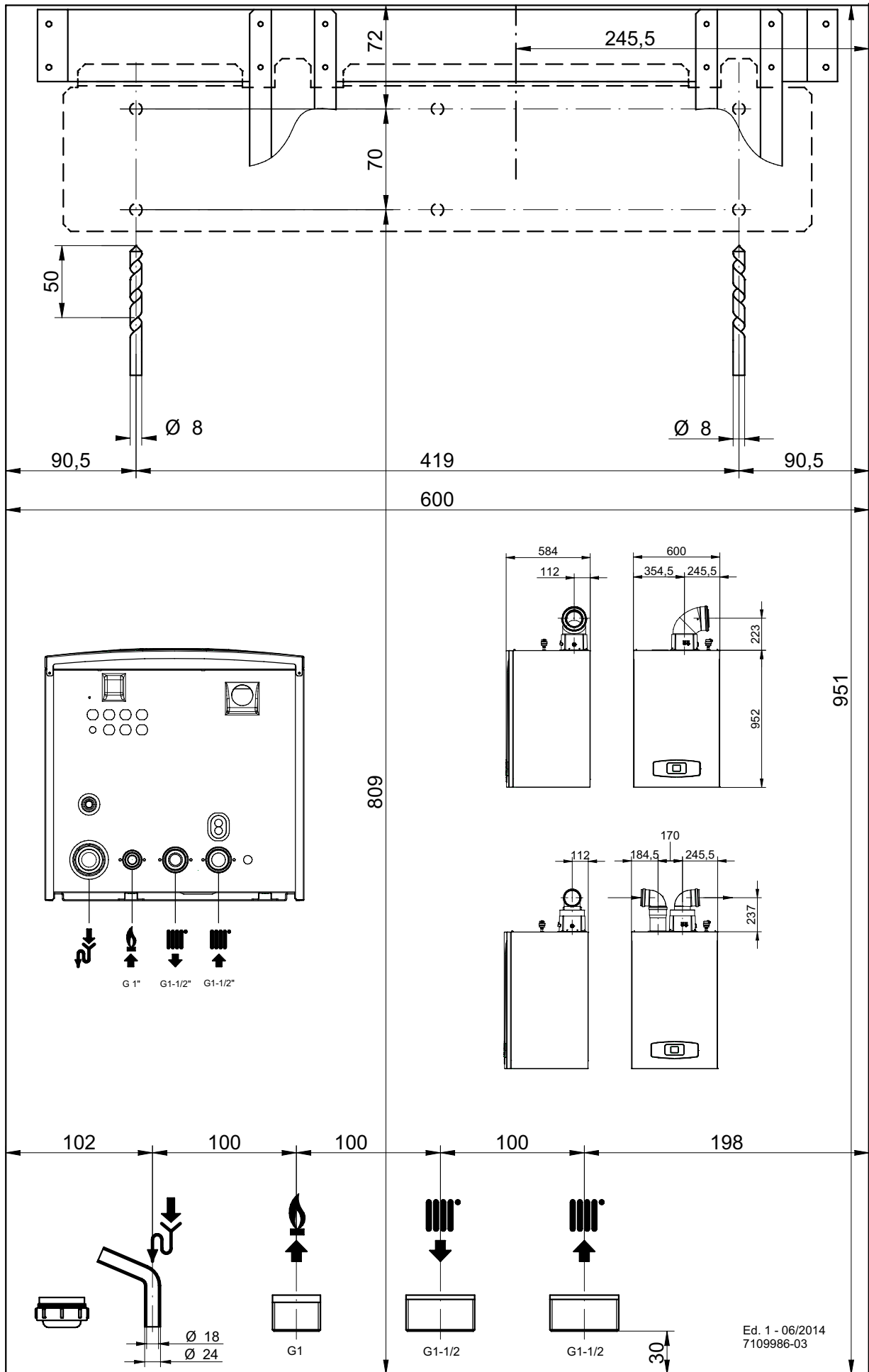

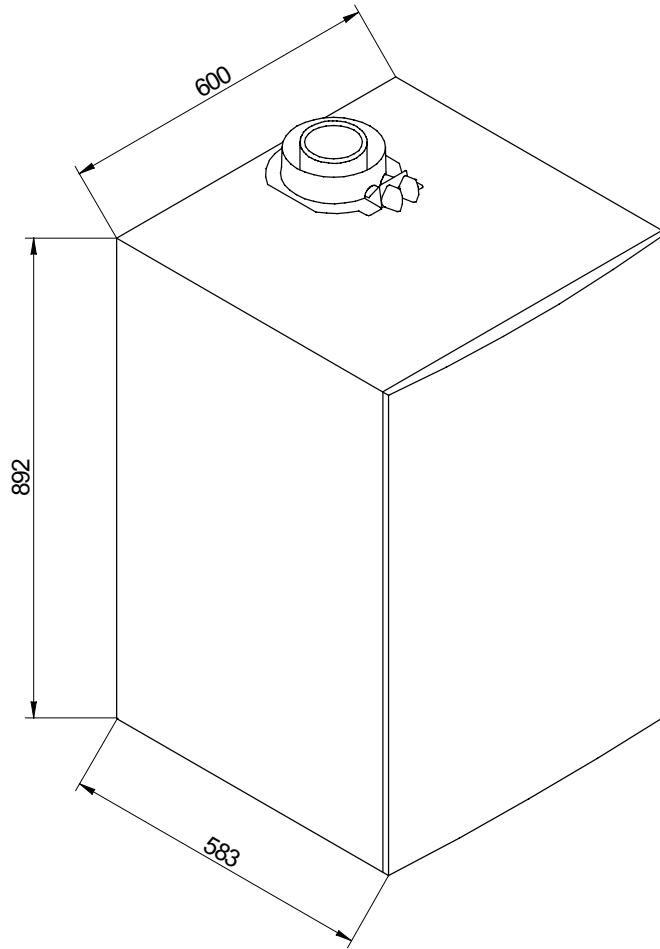

CR\_0775

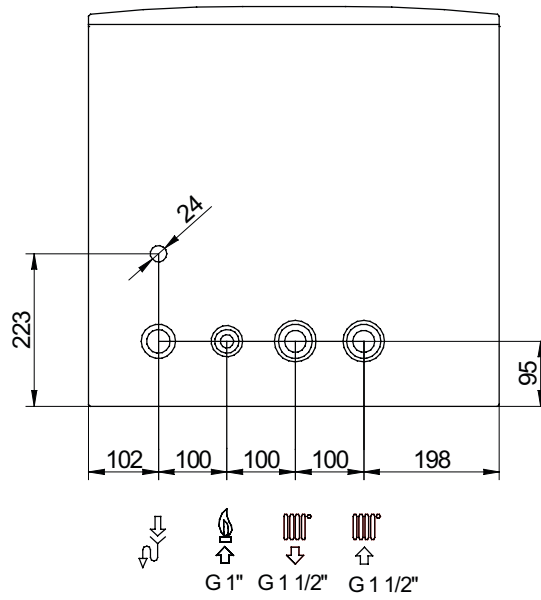

BOILER SCHEMATIC LAYOUT

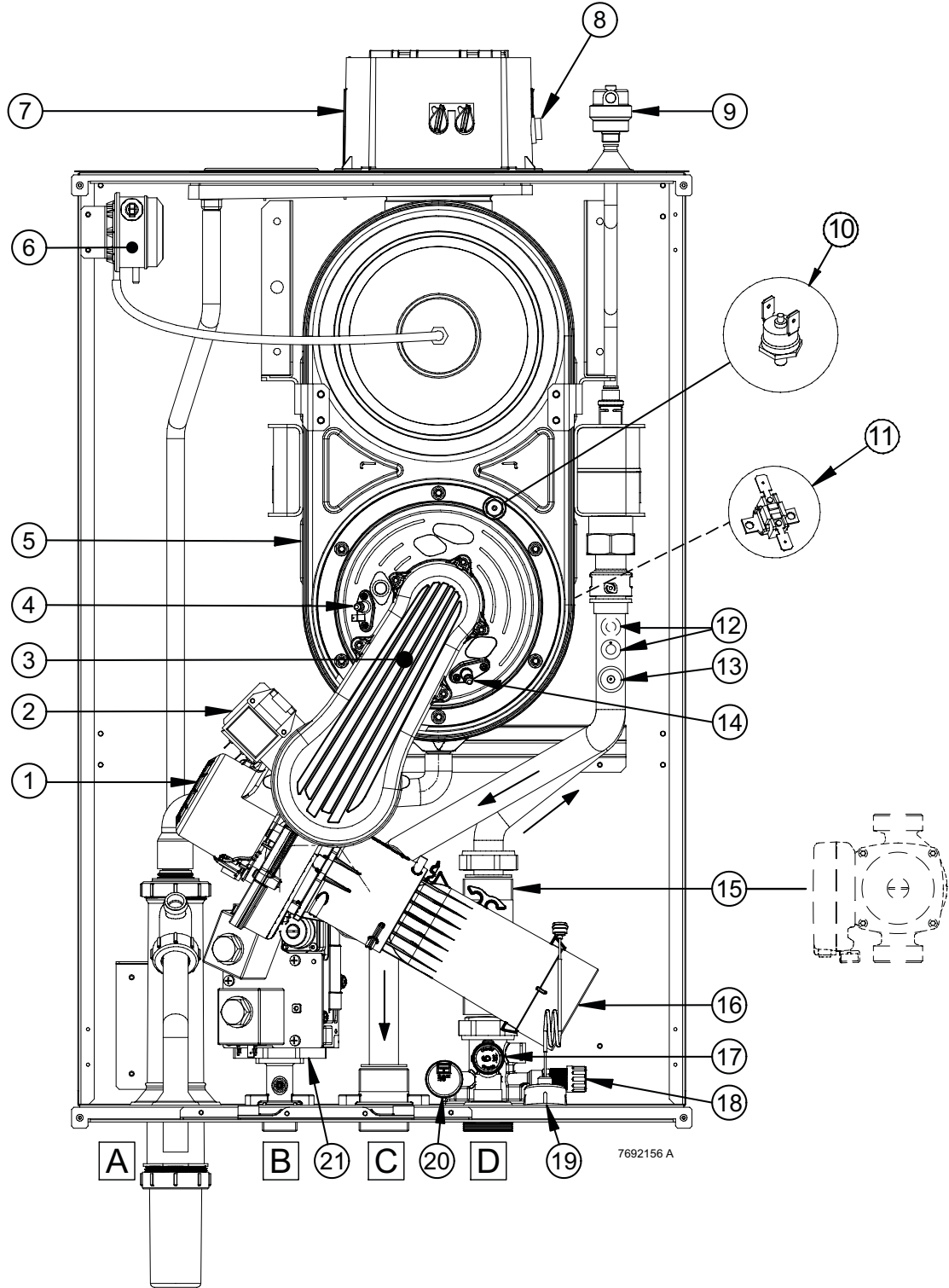

1	Fan	14	Flame detection electrode
2	Spark generator	15	Pump
3	Air/gas blend manifold	16	Venturi
4	Ignition electrode	17	Hydraulic Safety valve
5	Primary exchanger	18	Boiler drain tap
6	Fumes pressure switch	19	Pressure gauge
7	Coaxial flue connector	20	Hydraulic Pressure sensor
8	Flue sensor	21	Gas valve
9	Automatic air vent		
10	Exchanger flange thermostat	A	Siphon with condensate drain
11	Thermal fuse (rear)	B	Gas inlet connection
12	NTC water heating sensor (flow and return)	C	Heating flow connection
13	Safety overflow temperature thermostat	D	Heating return connection

### 3. INSTALLING THE FLUES

The boiler is easy and flexible to install thanks to the extensive range of available accessories, as described below. The boiler has been designed for connection to a vertical or horizontal concentric flue.

#### WARNINGS

**C13, C33** The terminals for separate flues must be fitted in accordance with the BS standard and the Clean Air Act 1993. Detailed instructions are provided with the individual accessories.



*For optimal installation, the accessories supplied by the manufacturer should be used.*

**TABLE 1A**

If the flue and air ducts installed are not supply by POTTERTON COMMERCIAL, make sure they are certified for the type of use and have a maximum pressure drop as indicated in the table to the side.

	$\Delta P$ (Pa)
WH-130	180
WH-150	270



To optimise operating safety, make sure the flues are firmly fixed to the wall with suitable brackets for every 1 metre of flue.



Make sure there is a minimum downward slope of 5 cm (3 degrees) per metre of duct towards the boiler.



*SOME OUTLET FLUE INSTALLATION EXAMPLES AND THEIR RELATIVE MAXIMUM LENGTHS ARE SHOWN IN CHAP. "CONCENTRIC FLUES".*

### 4. CONCENTRIC FLUES

This type of flue is used to discharge exhaust fumes and draw combustion air both outside the building. The 87° concentric bend allows the boiler to be connected to a flue-air in any direction as it can be rotated by 360°. It can also be used as a supplementary curve combined with a concentric flue or a 45° bend.

If fumes are discharged outside the building, the flue-air must protrude at least 200 mm from the wall to allow weathering surround to be fitted and sealed to avoid water infiltrations.

- The 87° bend reduces the total flue length by 1 metre.
- The 45° bend reduces the total flue length by 0.5 metres.
- The first 87° bend is not included when calculating the maximum available length.

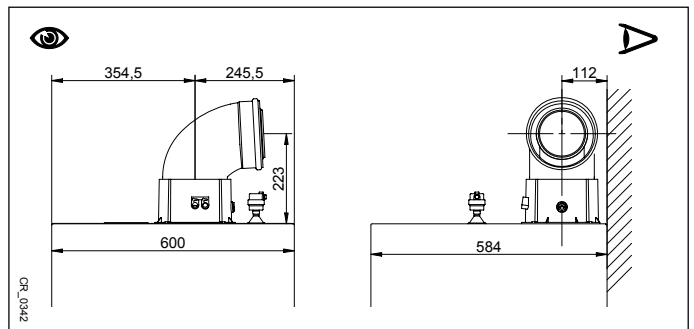

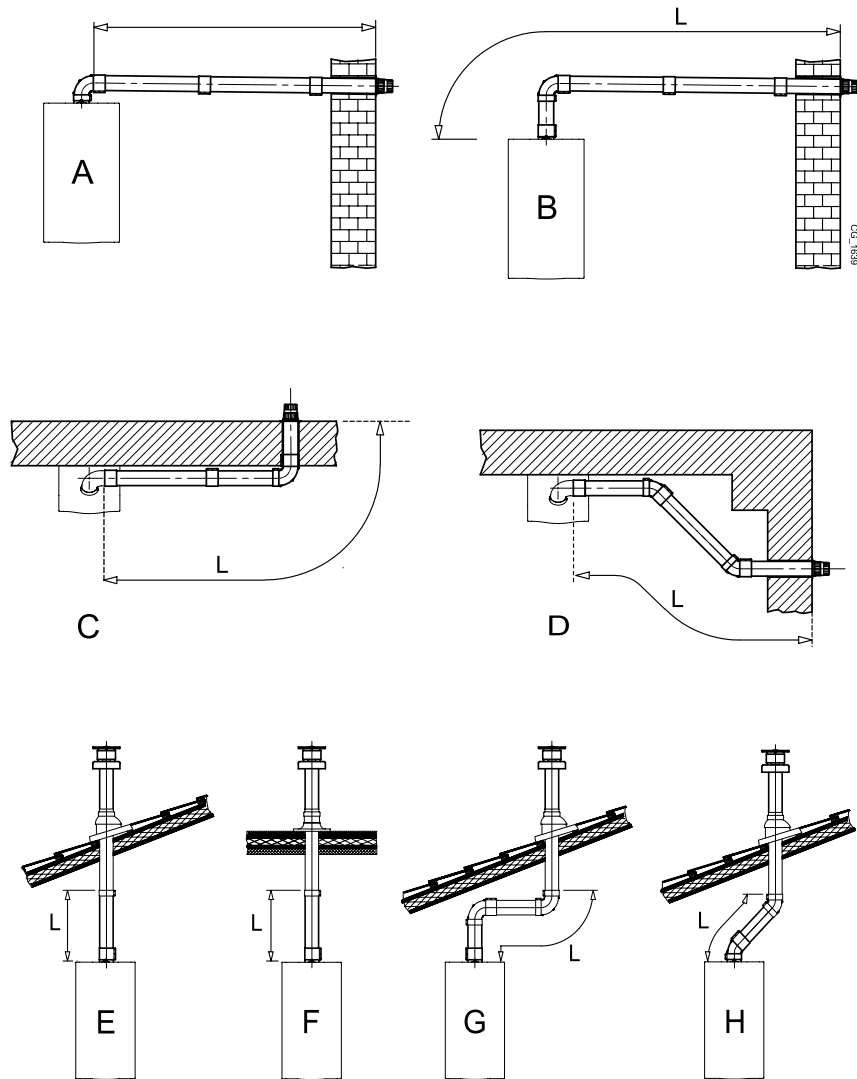

<b>A B</b>	$L_{max} = 8 \text{ m} - \text{Ø } 110/160 \text{ mm}$
<b>C D</b>	$L_{max} = 7 \text{ m} - \text{Ø } 110/160 \text{ mm}$
<b>E F</b>	$L_{max} = 8 \text{ m} - \text{Ø } 110/160 \text{ mm}$
<b>G</b>	$L_{max} = 6 \text{ m} - \text{Ø } 110/160 \text{ mm}$
<b>H</b>	$L_{max} = 7 \text{ m} - \text{Ø } 110/160 \text{ mm}$

## 5. CASCADE FLUES

This type of duct evacuates the products of combustion of more than one boiler in a cascade connection through a shared flue collector. The manifold has an incorporated clapet valve and must be used only to connect the boilers to the flue duct. The diameters available are: Ø160 mm and double diameter Ø160/250 mm. A range of accessories is available on request.

BOILER MODEL	MAXIMUM NUMBER OF BOILERS IN A CASCADE CONNECTION		PARAMETER 9524 Minimum power rpm	
	Ø 160 mm	Ø 160/250 mm	G20	G31
WH-130	2	4	1850	2000
WH-150	2	4	1850	2000

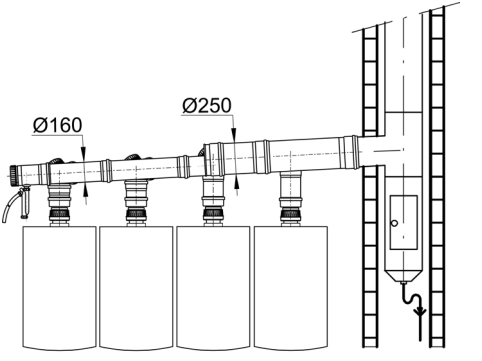

*In this outlet typology, a flue no-return valve, Ø 110/110 mm, must be fitted to each boiler. Change the parameter 9524 as shown in table following the procedure described in chapter 14.1.*



**The flue header size must be calculated by a qualified technician during the system design stage, as required by current regulations.**



## 6. GAS LINE PRESSURE DROP

In order to determine the actual working gas pressure at the boiler inlet the figure from the table below must be added to the measured pressure.

Model	Pressure drop (mbar) (Natural Gas)
WH-130	0,6
WH-150	0,8

## 7. BOILER PUMP

The boiler is supplied without the circulation pump. This component must be installed on the heating return to allow water to circulate between the boiler and the low loss header and can be purchased off the shelf or supplied by **POTTERTON COMMERCIAL** as an accessory (modulating pump).

- In the first case  the pump is installed on the heating return union near the boiler. To size it correctly see the Flow/Pressure drops chart in chap. "BOILER PUMP" (Size the pump in accordance to the  $\Delta T$  of the system design).
- In the second case  the pump is installed directly on the boiler removing the pipe on the internal circuit (first remove the front casing). For hydraulic performance data, see the Flow/Head charts in chap. "BOILER PUMP".

The water in the system is circulated by the relative pumps, see chap. "BOILER PUMP". Check that the flow of the water circulating in the boiler is not less than the value indicated in the following table.

Model	Minimum flow rate (l/h)	Operating flow rate (l/h) with POTTERTON COMMERCIAL low loss header
WH-130	2250	5400
WH-150	3150	5600

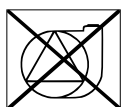

HYDRAULIC RESISTANCE

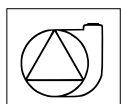
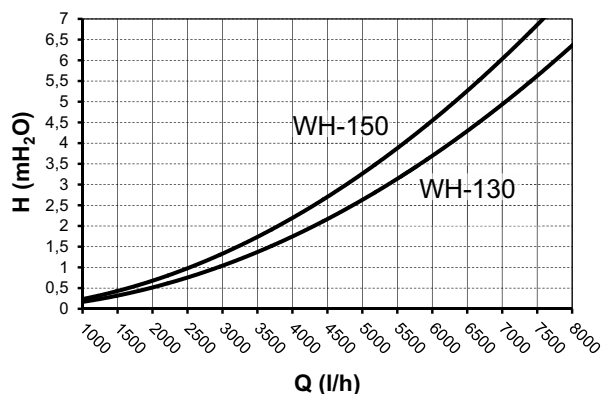

MODULATING PUMP OPERATION GRAPHS

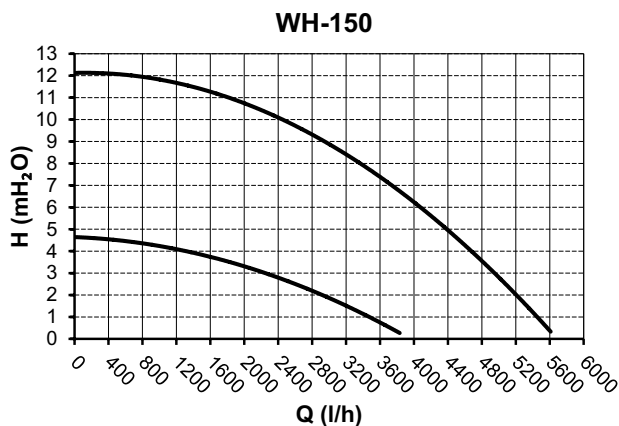
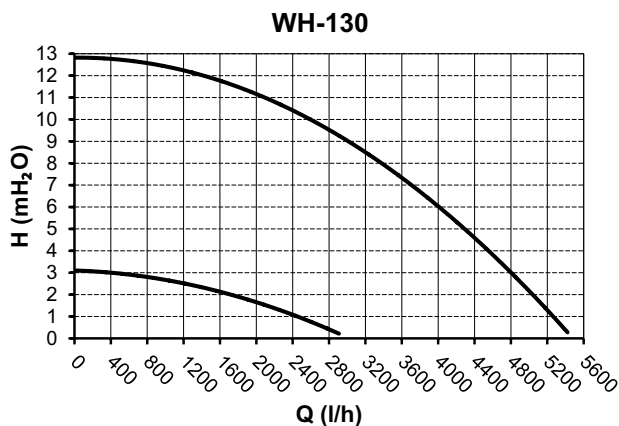

## 8. PUMP CAPACITY/ HEAD

The hydraulic pump, supplied as an accessory kit from POTTERTON COMMERCIAL, is a modulating pump. The purpose of the pump is to circulate the water between the boiler and the hydraulic separator.

KEY TO PUMP CHARTS - see chap. "BOILER PUMP"

Q	RATE OF FLOW
H	HEAD



THE PUMP FLOW / HEAD CHARTS CAN BE CONSULTED IN CHAP. "BOILER PUMP".

## 9. ELECTRICAL CONNECTIONS

This machine is only electrically safe if it is correctly connected to an efficient earth system in compliance with current safety regulations. Connect the boiler to a 230V single-phase earthed power supply using the supplied three core cable, observing correct Live-Neutral polarity.

**Use a double-pole switch with a contact separation of at least 3 mm.**

When replacing the power supply cable, fit a harmonised 3x0,75 mm<sup>2</sup> cable with a maximum diameter of 8 mm. To access the terminal block, remove the front boiler panel (fixed with two screws at the bottom), turn the control box downwards and access terminal blocks **M1**, **M2**, **M3**, used for the electrical connections, after removing the protective cover. The 3.15 A fast-blowing fuses are incorporated in the power supply terminal block (to check and/or replace the fuse, pull out the black fuse carrier).

SEE WIRING DIAGRAM IN CHAP. "ELECTRICAL CONNECTIONS"



Make sure that the overall rated power input of the accessories connected to the appliance is less than 2A. If it is higher, install a relay between the accessories and the electronic board.



The connections in terminal blocks M1- M3 are high voltage (230 V). Before making connections, make sure the appliance is disconnected from the power supply. Check the input polarity on terminal block M1: L (LINE) - N (NEUTRAL).

### TERMINAL BLOCK M1

(L) = Live (brown)

(N) = Neutral (light blue).

⊕ = Earth (yellow-green).

(1) (2) = contact for Room Thermostat.



Put back the jumper on terminals 1-2 of boiler terminal block M1 if the room thermostat is not used or if the Remote Control is installed.

### TERMINAL BLOCK M2

**Terminals 1 (back-lighting) - 2 (earth) - 3 (+12V):** connection to the Remote Control (low voltage) supplied as an accessory.

**Terminals 4 - 5 (common):** Outdoor temperature sensor

**Terminals 6 - 5 (common):** 2nd Auxiliary Sensor (sensors for solar plant, cascade system, zone system, etc.).

**Terminals 7 - 5 (common):** 1st Auxiliary Sensor (sensors for solar plant, cascade system, zone system, etc.).

**Terminals 9-10:** storage tank sensor connection.

**Terminal 8:** not used.

### TERMINAL BLOCK M3

**Terminal 1-2:** (230Vac - max 1A) power supply of modulating boiler pump (PWM)

**Terminal 2-3:** (max 1A) alimentazione pompa non modulante di caldaia (ON - OFF)

**Terminal 4:** not used

**Terminal 5-6:** PWM signal of the modulating pump

**Terminal 7-8:** not used

**Terminal 9 - 10:** Domestic Hot Water tank pump (max 1 Amp)

**Terminal 11 - 12:** Heating System pump (device connected downstream of the hydraulic separator - max 1 Amp)

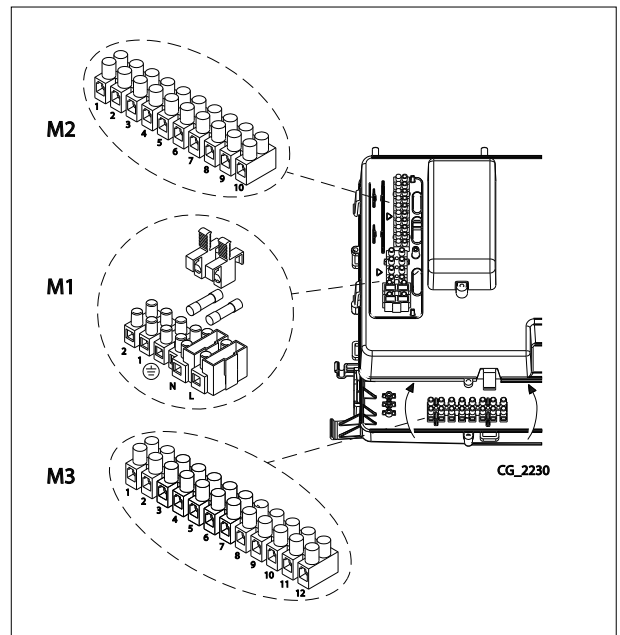

If the appliance is connected to an underfloor system, install a limit thermostat to prevent the circuit from overheating.



Use the relative cable grommets at the bottom of the boiler to thread the cables through to the terminal blocks.



A 250Vac/250Vac relay with a minimum current rating of 16A and able to withstand a starting current of above 100A is required to connect the external pumps.



# ILLUSTRATED WIRING DIAGRAMS

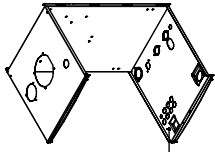

7734978

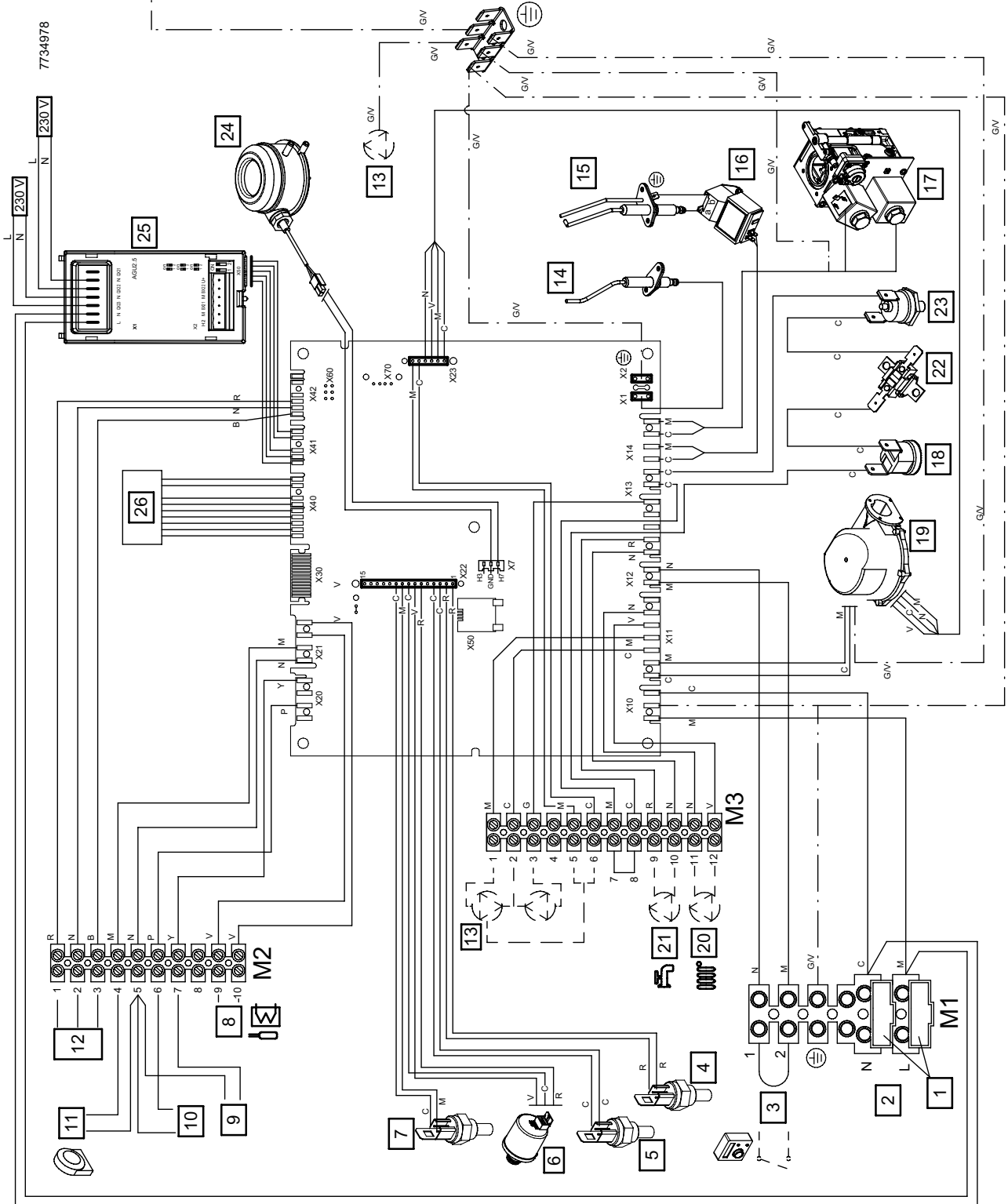

1	Fuses
2	230 V Power Supply
3	Room Unit (RU)
4	Heating flow sensor
5	Heating return sensor
6	Water pressure switch
7	Fumes sensor
8	DHW tank sensor
9	Auxiliary Sensor 1
10	Auxiliary Sensor 2
11	Outdoor sensor
12	Remote Control
13	Boiler pump
14	Flame sensor electrode
15	Spark electrode
16	Spark generator
17	Gas valve
18	Safety Thermostat 105°C
19	Fan
20	Heating circuit pump
21	DHW tank pump
22	Thermal fuse
23	Exchanger flange thermostat
24	Flue pressure switch
25	AGU 2.550
26	Bridge PCB
C	Blue
M	Brown
N	Black
R	Red
GV	Yellow/Green
V	Green
B	White
G	Grey
Y	Yellow
P	Violet

## 9.1 INSTALLING THE CONTROL PANEL ON THE WALL

For the boiler to work with the Control Panel mounted on the wall, purchase accessory **B** supplied with the base **B1** and position it on the boiler as shown in the figure. Also see the mounting and operation instructions supplied with the kit **B**. Proceed as follows:

- Switch off the boiler.
- Pass the three wires from the boiler terminal block **M2** through the hole in the base **B1** to apply to the wall.
- Connect wires **1-2-3** of the boiler terminal block **M2** to terminals **(1)-(2)-(3)** of the base terminal block **B1** respectively.
- Fix the base **B1** to the wall using the expansion grips and screws supplied with the accessory.
- Apply the Control Panel **A** to the base fixed to the wall, taking care not to apply excessive force.
- Place accessory **B** on the front boiler panel.
- Power the boiler making sure that the Control Panel lights up.



**The wire (1) from the boiler terminal block M2 powers the display backlighting (12 V). This wire does not have to be connected for the wall-mounted Control Panel to work.**

### KEY TO WALL-MOUNTED CONTROL PANEL CONNECTIONS

<b>A</b>	Control Panel	<b>B</b>	Led interface accessory	<b>B1</b>	Base for wall-mounted Control Panel
<b>(1)</b>	Display backlighting +12V	<b>(2)</b>	Earth connection	<b>(3)</b>	Power input/Signal +12V

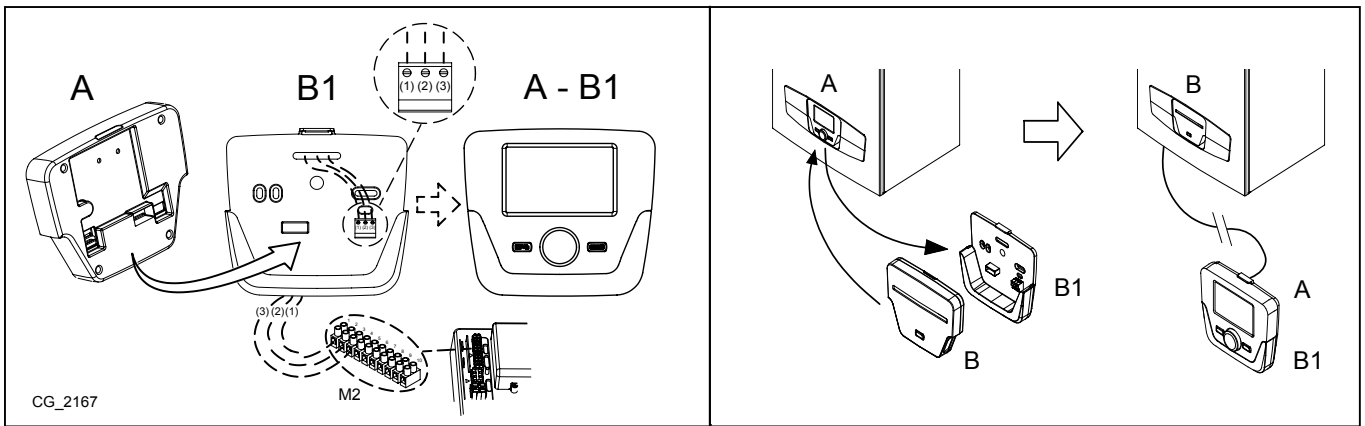

**For the wall-mounted Control Panel to work it must be configured (ambient probe and modulating flow temperature enabled).**

### 9.1.1 PARAMETERS SETTING



**ALL MODIFIED PARAMETERS SHOULD BE NOTED DOWN IN THE TABLE AT THE END OF THIS MANUAL.**

#### KEY TO FIGURE MENU

<b>1</b>	Enduser	<b>3</b>	Engineer
<b>2</b>	Commissioning	<b>4</b>	OEM

The following procedure is used to access the four boiler programming menus:

- from the main menu **C**.
- **A** and **C** (hold down for approx. 6 seconds) **B** menu **1-2-3-4** (see figure to side and key).
- **C** to go back one menu at a time to the main menu.

When the Control Panel is wall-mounted enable the **room sensor** and **flow temperature modulation** as follows:

#### A) ROOM SENSOR

- Access menu **2**.
- **B** **Operator unit** **B** to confirm.
- **B** programme row **40** (Used as) **B**.
- **B** (anti-clockwise) **Room unit 1** **B** to confirm (the room sensor is now active).
- **C** to return to the previous menu then **B** **Configuration** **B**.
- **B** programme row **5977** (Function input H5) then **B** to confirm.
- **B** **None** **B** to confirm.



**For correct operation of the environment unit during the reduced time band it is necessary to set the parameter 5977 = "none".**

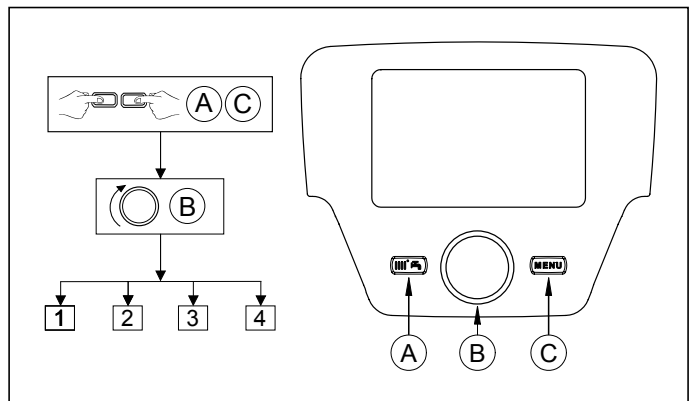

## B) FLOW TEMPERATURE MODULATION

To set flow temperature modulation, disable parameter **742** (HC1). Proceed as follows:

- Access menu **2**.
- **B** < **Temps / mode CH1** **B** to confirm **B** < **742** (Flow temp setpoint room stat) **B** to confirm.
- **B** (anti-clockwise) < "—" then **B** to confirm.



*If, when turning the knob B on the main menu, the display visualises the boiler flow temperature instead of the ambient temperature, parameter 742 has not been set correctly.*

After every system configuration (e.g.: solar combination, connection an external storage boiler, etc.) perform the following procedure to update the boiler board to the new configuration:

- Access menu 2 as indicated at the beginning of this section.
- **B** < **Configuration** **B** < programme row **6200** then **B**.
- **B** < **Yes** then **B** to confirm.

## ZONE SYSTEM WITH INSTALLATION OF THE REMOTE CONTROL

The electrical connection and the adjustments required to manage a system divided into zones with use of the Remote Control differs according on the accessories connected to the boiler. To install and configure, see the instructions of the **Expansion Module** supplied as an accessory.

## ADJUSTING THE TEMPERATURE OF THE HIGH TEMPERATURE HEATING SYSTEM

To avoid frequent starting and stopping, raise the minimum temperature setpoint of the boiler in the heating mode by setting parameters **740**, to not less than 25°C, using the procedure described in point **B**.

## TEMPERATURE ADJUSTMENT ON LOW TEMPERATURE HEATING SYSTEM

For a low temperature system (such as underfloor heating), reduce the maximum CH temperature setpoint on the boiler by setting parameter **741** (point B) to a value not greater than 55°C.

## 9.2 OUTDOOR SENSOR

The External Probe can be connected to the boiler as illustrated in the figure to the side. The following procedure is used to set a parameter, called **room influence** which is used to determine the importance of the ambient temperature with respect to the external temperature and vice-versa (the factory setting is 50%-50%).

*E.g.: if the ambient influence is set to 60%, the influence of the External Probe will consequently be 40% (the greater the set value of ambient influence, the lesser the influence of the External Probe will be in proportion, and vice-versa).*

The following procedure is used to set ambient influence:

- **C** then **A** and **C** (approx. 6 seconds) < Enduser – Commissioning - Engineer - OEM.
- **B** < **"Commissioning"** **B** to confirm.
- **B** < **"Temps / mode CH1"** **B** to confirm.
- **B** < programme row **750** (Room influence) **B** to confirm.
- **B** and choose the % value to assign to the parameter that determines how much the ambient affects the system then **B** to confirm.
- **C** to return to the previous menu.

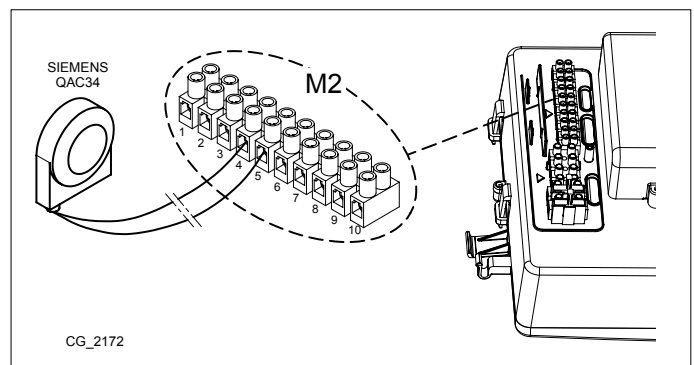

## SETTING THE "Kt" CLIMATE CURVE

To set the climate curve **Kt**, access **menu 2** as described in section 9.1.1 and proceed as follows:

- **B** < **720** (Heating curve slope) **B** to confirm
- **B** < **(from 0.10 to 4)** **B** to confirm.
- Select the climate curve from among those available, see the curve chart in chap. **"OUTDOOR SENSOR"** (the preset curve is 1.5).

KEY TO CURVE CHART **Kt** - see chap. **"OUTDOOR SENSOR"**

	Flow temp		Outside temp
--	-----------	--	--------------

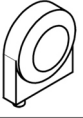

## WEATHER COMPENSATION CURVE GRAPHS

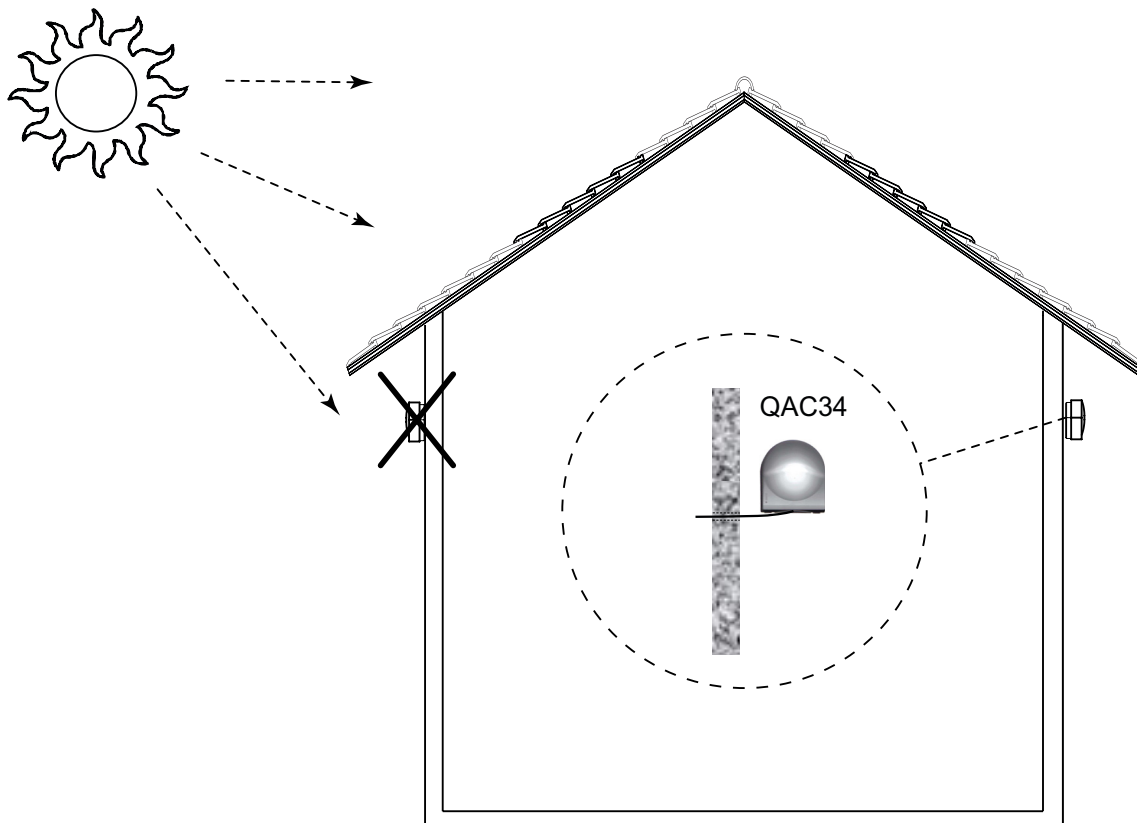
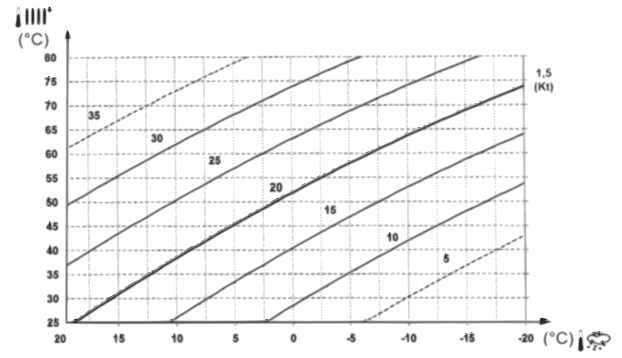
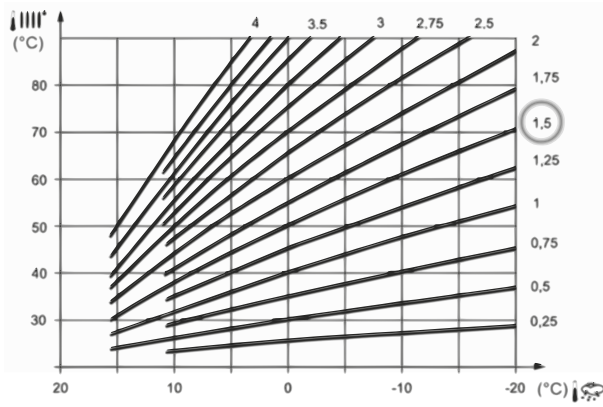

## 10.ACCESSORIES NOT INCLUDED IN THE PACKAGING

### 10.1 WIRING OF BOILER PUMP

Connect the boiler pump to terminals 1-2 of the **M3** terminal block as described in section 9. If the pump is a modulating pump connect the **PWM** signal to the terminals 5-6 of the **M3** terminal block.

### 10.2 HEATING SYSTEM PUMP

Install the system pump downline from the hydraulic separator. Choose the pump according to the required system capacity/head characteristics (see chap. "**BOILER PUMP**").



A 250Vac/250Vac relay with a minimum current rating of 16A and able to withstand a starting current of above 100A is required to connect the external pumps.

### 10.3 DOMESTIC HOT WATER CYLINDER

The boiler can be electrically connected to an external storage tank. A diagram of the hydraulic connection of the external storage tank is shown in chap. "**DIAGRAMS**". Connect the storage tank pump to terminals 9-10 of the **M3** terminal block (see chap. "**ELECTRICAL CONNECTIONS**"). Install the storage boiler downline from the hydraulic separator. Use the sensor supplied as an accessory and connect it to terminals 9-10 of terminal block **M2** (see chap. "**ELECTRICAL CONNECTIONS**"). Make sure that the exchange capacity of the domestic hot water coil is appropriate for the power of the boiler.



A 250Vac/250Vac relay with a minimum current rating of 16A and able to withstand a starting current of above 100A is required to connect the external pumps.



The anti-legionellosis function is NOT ENABLED. To enable it, set parameter 1640 as described below.

To activate the **ANTILEGIONELLOSIS** function, proceed as follows:

- Access MENU 2 as described in section 9.1.1.
- **Temps / mode hot water** programme row **1640** then to confirm.
- **Periodically** or **Fixed weekday** then choose one of the two items and to confirm.

Choose **Periodically** to enable the function once a week on the set day and at the set time. To set the day and time, use the same procedure described above: set parameter **1641** to establish which days (from 1 to 7) the function must activate and parameter **1644** to set the starting time of the function.

Choose **Fixed weekday** to enable the function once a week on the set day and at the set time. Set parameter **1642** to establish the day of the week (from Monday to Sunday) on which the function must activate and parameter **1644** to set the start time of the function.

### 10.4 MIXED ZONES (see chap. "DIAGRAMS")

A mixed zone can be managed using the **AVS75** external module, supplied as an accessory. This accessory can manage: a zone pump, a mixing valve, a temperature sensor, a limit thermostat and a room thermostat. To connect the components and adjust the system read the manual provided with the accessory.

### 10.5 OUTDOOR SYSTEM MANAGEMENT MODULES

The boiler can independently manage up to three heating circuits by using external accessories such as room units, remote controls and external modules (AVS 75.391 and AVS 75.370). The boiler electronics also comprises a wide range of functions for personalising and managing various system types. To assure correct system operation, a number (from 1 to 3) must be assigned to each accessory in order to allow the boiler board to recognise it. Consequently, carefully read the instructions provided with the accessories. The external module AVS 75.370 can be used to control modulation of 2 pumps: a zone pump and/or the storage boiler pump.

### 10.6 BOILERS IN A CASCADE CONNECTION (see chap. "DIAGRAMS")

The **AVS75** external unit, supplied as an accessory, is used to manage a heating system with up to 16 boilers connected in a cascade arrangement and a possible separate storage tank providing domestic hot water. This accessory, connected to one of the cascade boilers, can directly control the circuit components up to a maximum of 3 independent relay outlets, 2 temperature sensors, 1 high voltage limit thermostat connector and one 1 control input (e.g.: room thermostat). The system also requires an **OCI 345** interface on each boiler comprising in the cascade arrangement.



THE HYDRAULIC DIAGRAMS OF THE CASES DESCRIBED CAN BE FOUND IN CHAP. "DIAGRAMS".

### 10.7 AGU 2.550

Use the **AGU 2.550**, already installed in the boiler, to send information from the boiler as described below to a BMS panel.

ELECTRICAL CONNECTION	
X1 (L-N)	Power supply (230V 50Hz AC) connected to the boiler terminal block M1 (C+M)
X1 (QX21)	Not used
X1 (QX22-N)	Boiler OPERATION (light on = run)
X1 (QX23-N)	Boiler ALARM (light on = lockout)
X2 (H2-M)	INPUT Electrical Signal 0÷10 V

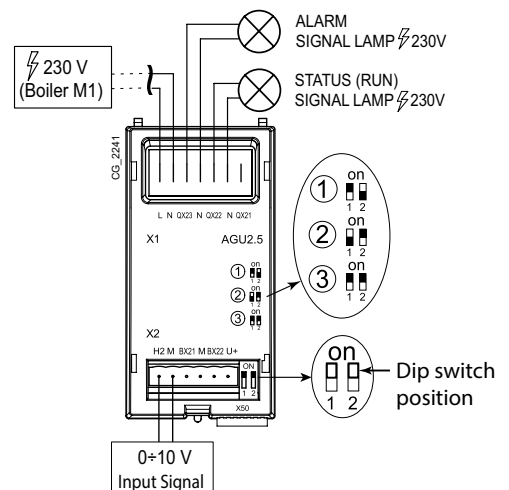

## 10.8 CONNECTING THE ROOM THERMOSTAT



The connections in terminal block M1 are in high voltage (230 V). Before making connections, make sure the appliance is disconnected from the power supply. Check the polarity: L (LIVE) - N (NEUTRAL).

To connect the Room Thermostat to the boiler, proceed as described below:

- Switch off the boiler;
- Access the terminal block **M1**;
- Remove the jumper from the ends of contacts **1-2** and connect the wires of the volt free Room Thermostat;
- Switch on the boiler and make sure the Room Thermostat works correctly.

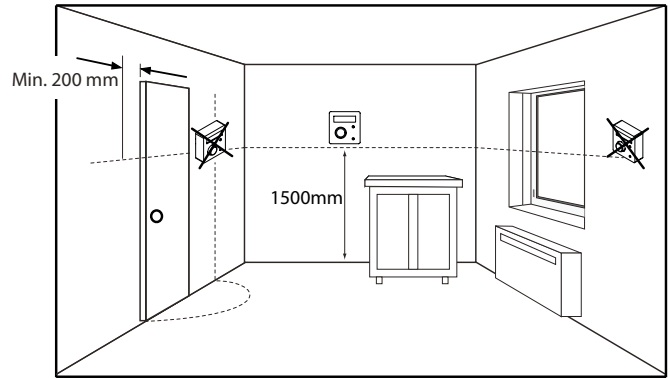

## 11. COMMISSIONING THE BOILER

When the boiler is powered up, the code "311" appears on the display and the boiler is ready for "initial ignition". Follow the procedure "SYSTEM AIR EXTRACTION FUNCTION" as described in the section below and enable programme 312. After this operation, the boiler is ready to ignite the burner.

To light the boiler correctly, proceed as follows:

- Check that the system pressure is correct (section 12);
- Power the boiler;
- Open the gas tap.



Before initial ignition ensure the gas line has been purged of air and tested for soundness as per current standards, see section OPERATING MODES.

### CONTROL PANEL

Key to SYMBOLS	
	Burner lit (Power %: 1<70% - 2>70%)
	Operating mode: comfort ambient temperature
	Operating mode: reduced ambient temperature (only if installed indoors)
	Operating mode in heating: 1 = zone 1 - 2 = zone 2 - 3 = zone 3
	Operating mode: DHW enabled
	Operating mode: AUTOMATIC
	Operating mode: MANUAL
	Ambient temperature (°C)
	External temperature (°C)
	Off: heating and DHW disabled (only boiler anti-freeze protection is active)
	Flue cleaner function enabled
	Holiday programme function enabled
	Data transmission (only if the WIRELESS device is connected)

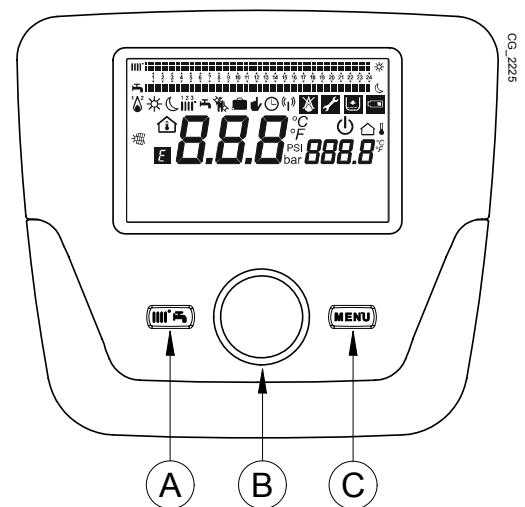

	Connection to SOLAR plant
	Fault
	Fault preventing the burner from lighting
	Technical Service Centre call-in
	Boiler/system water pressure low
	Set unit of measurement (SI/US)

# 11.1 BASIC CONTROL PANEL SETTINGS

## INITIAL IGNITION CONFIGURATION PROCEDURE

When igniting the boiler for the first time, perform the following procedure (the text is written in **ENGLISH** until the user is requested to set his/her language as illustrated in sequence A-B-C of the figure indicated below):

- **B** for 5 seconds;
- the display shows a percentage value from 1 to 100. Data synchronisation takes a few minutes to complete;
- set the language, date and time.

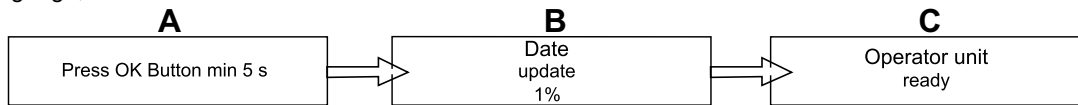

## 12. FILLING THE SYSTEM

The pressure displayed on the pressure gauge has to be between 1 - 1.5 bar, with the system cold. If it is lower, turn the system filling tap installed by the fitter.

**IMPORTANT:** open the tap very slowly in order to vent the air.



The boiler is fitted with a hydraulic pressure switch which prevents the boiler from working if there is no water.



If pressure drops occur frequently (monthly basis), have the system checked by the Authorised technical service agent.

## 13. SYSTEM AIR EXTRACTION FUNCTION

This function is used to facilitate the elimination of the air inside the heating circuit when the boiler is first installed or after maintenance when the water is drained from the primary circuit and re-filled. The electronic board will activate a pump on/off cycle lasting 10 minutes. The function will automatically stop at the end of the cycle.



To manually interrupt the function, repeat the procedure described above. When the function is disabled, "off" is shown on the display.



During this phase it is recommended to keep the pressure in the system at a value between 1 and 1.5 bar.

## 14. GAS VALVE COMMISSIONING

To commission the gas valve, enable the commission function as described in section "SPECIAL FUNCTIONS" and carry out the following operations:

### 1) Calibrating MAXIMUM heat output.

Check that the  $CO_2/O_2$  measured on the flue duct, with the boiler operating at maximum heat capacity, matches that indicated in table 1C. If it does not, remove the threaded cap on the gas valve and turn the adjustment screw (V). Turn the screw clockwise to decrease the level of  $CO_2$  and anti-clockwise to increase it.

### 2) Calibrating REDUCED heat output

Check that the  $CO_2/O_2$  measured on the flue duct, with the boiler operating at minimum heat capacity, matches that indicated in table 1C. If it does not, remove the threaded cap on the gas valve and turn the adjustment screw (K). Turn the screw clockwise to increase the level of  $CO_2$  and anticlockwise to decrease it.

<b>V</b>	Gas flow adjustment screw	<b>Pi</b>	Gas supply pressure tap
<b>K</b>	OFFSET adjustment screw		

For each  $CO_2/O_2$  value found at the maximum thermal capacity, there is a range of  $CO_2/O_2$  values at the minimum thermal capacity shown in the same line of the table.

The nominal calibration values of the gas valve for each type of gas used are shown in bold.

The  $CO_2/O_2$  values are with the cover closed.

The maximum permitted CO value must be lower than 250 ppm.

TABLE 1C

G20 (Natural Gas)				G31 (Propane Gas)			
CO <sub>2</sub> (%)		O <sub>2</sub> (%)		CO <sub>2</sub> (%)		O <sub>2</sub> (%)	
P max	P min	P max	P min	P max	P min	P max	P min
9,7	8,8+9,2	3,6	4,5+5,2	10,5	10+10,4	4,9	5,1+5,7
9,6	8,7+9,1	3,8	4,7+5,4	10,4	9,9+10,3	5,1	5,2+5,8
9,5	8,6+9	3,9	4,8+5,6	10,3	9,8+10,2	5,2	5,4+6
9,4	8,5+8,9	4,1	5+5,7	10,2	9,7+10,1	5,4	5,5+6,1
9,3	8,4+8,8	4,3	5,2+5,9	10,1	9,6+10	5,5	5,7+6,3
<b>9,2</b>	<b>8,3+8,7</b>	<b>4,5</b>	<b>5,4+6,1</b>	<b>10</b>	<b>9,5+9,9</b>	<b>5,7</b>	<b>5,8+6,4</b>
9,1	8,2+8,6	4,7	5,6+6,3	9,9	9,4+9,8	5,8	6+6,6
9	8,1+8,5	4,8	5,7+6,5	9,8	9,3+9,7	6,0	6,1+6,7
8,9	8+8,4	5	5,9+6,6	9,7	9,2+9,6	6,1	6,3+6,9
8,8	7,9+8,3	5,2	6,1+6,8	9,6	9,1+9,5	6,3	6,4+7,1
8,7	7,8+8,2	5,4	6,3+7	9,5	9+9,4	6,4	6,6+7,2

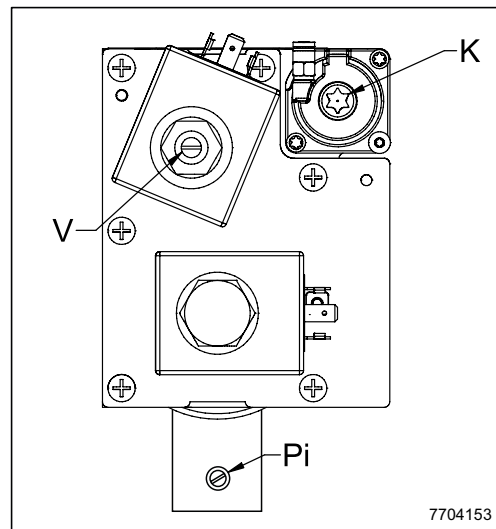

7704153



## 14.1 GAS CONVERSION



When converting from natural gas to propane (LPG), before calibrating the gas valve as described above, replace the gas nozzles (A) as indicated in the figure. Afterwards, make sure there are no gas leaks. Modify the parameters (fan rpm) as indicated in table 2.



For cascade ducts change the parameter 9524 (see table in chapter 5).

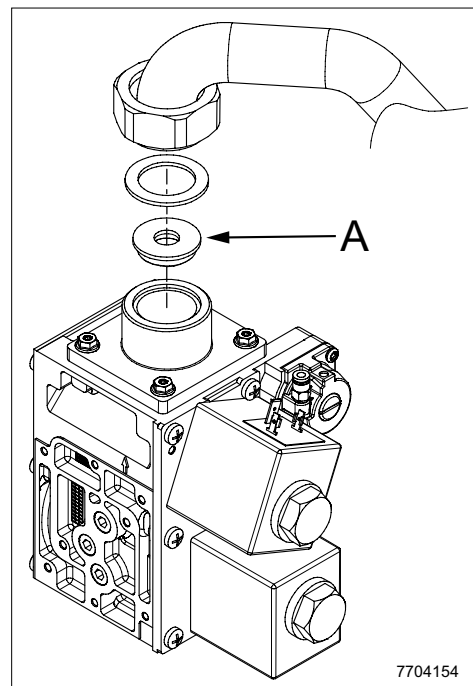

**TABLE 2**  
Access MENU 2 as described in section PARAMETERS SETTING.

- **Boiler Settings** **B** **B** **2441** **B**.
- **B** **B**.
- **C** **Boiler control** **B**.
- **B** **9524** **B**.
- **B** **B**.
- **B** **9529** **B**.
- **B** **B**.
- **B** **9512** **B**.
- **B** **B**.

Boiler model	PARAMETERS - rpm					GAS NOZZLES Ø (mm)	
	9524		2441 - 9529	9512			
	Min. power		Max. power	Ignition power			
	G20	G31	G20 - G31	G20	G31	G20	G31
<b>WH-130</b>	1550	1950	5800	2500	2700	12	11
<b>WH-150</b>	1800	2000	6900	2500	2700	12	11

## 15. SPECIAL FUNCTIONS

Available functions are:

- **Chimney sweeper** (programme row **303**) - Options: Full load (maximum thermal power of the boiler), Part load (reduced thermal power), Full heating load (maximum thermal power in the heating mode).
- **Controller stop function** (**304**) - Options: from 100% (maximum thermal power) to 0% (reduced thermal power). This function facilitates gas valve calibration operations.
- **Manual control** (**301**) - Options: 25 - 90 (° C) In this mode the boiler operates at the set temperature value.
- **Deaeration function** (**312**) - Options: On (function enabled) - Off (function disabled). See section "System air extraction function".

The procedure used to enable these functions is the following:

- From the main menu **A** and **C** (hold down for approx. 6 seconds) names of the FUNCTIONS (see figure to side: 303 - 304 - 301 - 312)
- **B** to choose the FUNCTION **B** to ENABLE the chosen function then **B** FUNCTION menu **B** to edit (see example below).

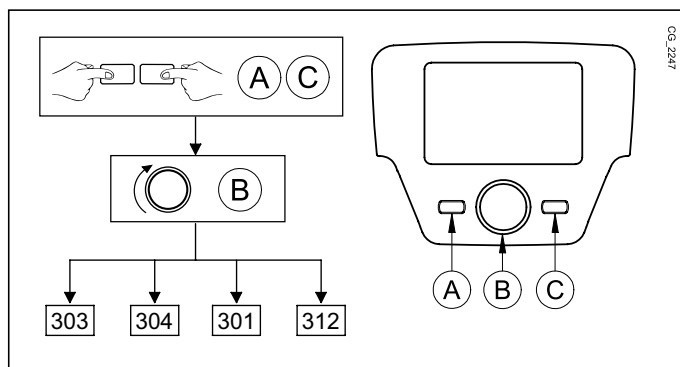



**E.g.:** turn knob **B** to enable the **CALIBRATION** function (programme row **304**), press knob **B**, the function is now active and preset to 100% (the boiler is at its maximum thermal power). Press the knob and turn it to select the required power percentage (0% corresponds to the reduced thermal power level).



To manually interrupt the function, repeat the procedure described above. When the function is disabled, "off" is shown on the display.



## 16. TEMPERATURE ADJUSTMENT

To adjust the temperature, turn knob **B** to the right  to increase and to the left  to decrease than  **B** to confirm.

### CENTRAL HEATING

The temperature to adjust can be:

- **Flow temperature:** if the Control Panel is installed on the boiler.
- **Ambient temperature:** if the Control Panel is installed on the wall.

### DOMESTIC HOT WATER

To adjust the Domestic Hot Water setpoint, select the "Hot water temp setpoint" function as described in section 3 and  **B** to set the request temperature value.

## 17. OPERATING MODES



### 17.1 HEATING

The boiler can operate in 4 different ways in the heating mode: On - Reduced - Timed - Off. To set one of the operating modes, proceed as follows:

#### CASE 1 : the Control Panel is installed in the boiler

Turn knob **B** to adjust the boiler flow temperature.



##### DESCRIPTION OF OPERATING MODES

- **On:** heating is always enabled (symbols displayed .
- **Reduced:** heating is always disabled (symbols displayed .
- **Timed:** heating depends on the set time band (symbols displayed .
- **Off:** heating is disabled.

#### CASE 2 : the Control Panel is installed on the wall

Turn knob **B** to adjust the ambient temperature of the room to heat.

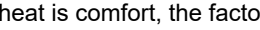
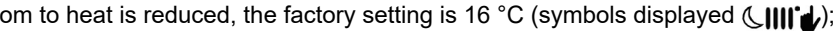
##### DESCRIPTION OF OPERATING MODES

- **On:** the temperature of the room to heat is comfort, the factory setting is 20 °C (symbols displayed .
- **Reduced:** the temperature of the room to heat is reduced, the factory setting is 16 °C (symbols displayed .
- **Timed:** heating depends on the set time band (symbols displayed .
- **Off:** the boiler start when the room temperature falls below 6°C.













*When the boiler operates in the Timed mode, turn the knob **B** to temporarily adjust the temperature. This modification remains valid until the subsequent time band change.*



*The boiler anti-freeze is always active, the boiler ignites when the flow temperature falls below 5 °C. The function operates if the appliance is electrically powered and there is gas.*

#### 17.1.1 ADJUSTING THE REDUCED AMBIENT HEATING TEMPERATURE

To set the **Reduced** ambient temperature, proceed as follows:





















-  **C**  **B**  "Temps / mode CH1"  **B**.
-  **B**  programme row **712** (Reduced temperature) then  **B** (the temperature value starts flashing) ;
-  **B** to edit the temperature and  **B** to confirm.
-  **C** to return to the previous menu.

Apart from using key **A** of section 3, the comfort ambient temperature can also be adjusted by editing parameter **710**, as described above.

### 17.2 HOLIDAY PROGRAMME

This function allows the user to choose what ambient temperature value to set during his/her absence (for example, during a holiday). The minimum **anti-freeze** temperature or the **reduced** temperature (programme row **648**) can be set. Programme row **641** (Select) features 8 programming levels called **Period 1** (8 programmable on/off time bands). When the function is enabled, the symbol  appears on the display.

The procedure to follow to enable the function and programme the time bands is shown below:

-  **C**   **Holiday Heating 1**
-  **B**  programme row **641** ("Preselection")  **B** **Period 1** (flashing)  **B** and select which one to set (from 1 to 8) then  **B**  programme row **642**.
-  **B** to set the start period (**642**)  **B**  **B** to set the month  **B** and  **B** to set the day  **B** to confirm.
- Repeat the same sequence of instructions to set programme row **643** (end of period, the boiler will become operative again the following day).
- After programming the start and end of the period  **B**  programme row **648**  **B**  **B** to set the minimum operating temperature **anti-freeze** or **reduced** and  **B** to confirm.
- Repeat these three points to set other periods or  **C** to return to the previous menu.

# 18. HOURLY PROGRAMMING



Before proceeding with programming, enable the Timed operating mode (section OPERATING MODES).

Hourly programming in the heating mode (Time central heating CH1) and in the DHW mode (Time hot water) is used to set the automatic operation of the boiler in certain daily time bands and in certain days of the week. The example indicated in the following figure refers to the daily time band 1 (see below) where **a** is the operating period at the comfort temperature and **b** is the operating period in the reduced mode (section OPERATING MODES). Boiler settings can be adjusted by **groups of days** or by **single days** (every day from Mon to Sun).

## PRESET WEEKLY INTERVALS (Programme row 500 for heating and 560 for DHW)

- Mon - Sun (groups of days)
- Mon - Fri (groups of days)
- Sat - Sun (groups of days)
- Mon - Tue - Wed - Thu - Fri - Sat - Sun (single days)

## PRESET DAILY TIME BANDS (Programme row 514 for heating and 574 for DHW)

- 06:00-08:00 .. 11:00-13:00 .. 17:00-23:00 (example in figure to side)
- 06:00-08:00 .. 17:00-23:00
- 06:00-23:00

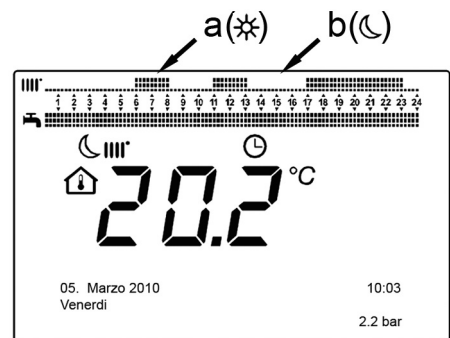

## 18.1 GROUPS OF DAYS

This function is used to set one of the 3 available weekly intervals, each with three hourly time bands for switching the boiler on and off. These are preset but can be modified by the user - programme rows 501...506. The intervals are:

**Mon - Sun** (factory setting) / **Mon - Fri** / **Sat - Sun**.



If the system is divided into zones, each with its own Control Panel/Ambient Unit, each single zone must be individually set on each device.

## 18.2 SINGLE DAYS

The daily boiler switching on and off phases can all be modified by the user. The 3 pre-set time bands are available for each single selected day, as indicated in the table at the end of this section.

## 18.3 HOURLY PROGRAMMING EDIT PROCEDURE (heating / DHW)

After performing hourly programming using the preset programmes, it is always possible to modify the three time bands - programme rows 501...506 for heating and 561...566 for DHW as described below.

### HEATING CIRCUIT PROGRAMMING EDIT PROCEDURE

- **C** **B** "Time central heating CH1" **B** programme row 500 (Select days).
- **B** and the **groups of days** field (section GROUPS OF DAYS) starts flashing **B** to scroll the days ("Groups of days" or "Single days") **B** to confirm.
- **B** programme row 514 (Select default timings?) **B** and **B** to select one of the 3 pre-set programmes of the "Groups of days" hourly programming (section GROUPS OF DAYS) or **B** clockwise by a click to pass to manual programming: programme rows 501....506.

### DHW CIRCUIT PROGRAMMING EDIT PROCEDURE

The procedure for enabling hourly programming of the DHW is the same as the hourly programming for the heating circuit. The only difference is the name of the menu "Time hot water" and the programme rows to set 560 (Select days). To disable this function, follow the procedure described in the "Resetting the Original Factory Programme" section.

### SUMMARY TABLE

GROUPS OF DAYS	PROGRAMME ROW 514 (heating) / 574 (DHW)		
Weekly interval	Preset programmes		
	On1 – Off1	On2 – Off2	On3 – Off3
<b>Mon-Sun</b>	06:00 – 08:00	11:00 – 13:00	17:00 – 23:00
<b>Mon-Fri</b>	06:00 – 08:00		17:00 – 23:00
<b>Sat-Sun</b>	06:00 – 23:00		
SINGLE DAYS	PROGRAMME ROWS 501 502 503 504 505 506 (heating) / 561 562 563 564 565 566 (DHW)		
Daily interval	Preset programmes		
	On1 – Off1	On2 – Off2	On3 – Off3
<b>Mon-Tue-Wed-Thu-Fri-Sat-Sun</b>	06:00 – 08:00	11:00 – 13:00	17:00 – 23:00



To simplify programming existing programmes can be copied to other days of the week. The following procedure is used.

## COPYING A PROGRAMME TO ANOTHER DAY

After programming the time band of a certain day, it can be copied to one or more days of the week.

The parameter between brackets "( )" refers to hourly programming in DHW

- From programme row **514 (574)** (if one of the 3 preset time bands has been used) or from programme row **501 (561)** (if manual programming has been performed) turn the knob clockwise to programme row **515 (575)**.
- **Copy?** appears on the display.
- **B** <|≡ **Copy to** and the day of the week flashes.
- **B** to scroll the days of the week, select which to copy the programme to and **B** to confirm.
- Repeat the above point to copy the same daily programme to other days.
- **C** to return to the previous menu.

## RESETTING THE ORIGINAL PROGRAMMING (FACTORY SETTING)

The weekly programming can be cancelled by enabling heating in the comfort mode (the set value is **00-24**, equal for all the days of the week).

- **C** **B** <|≡ **Time central heating CH1** **B** <|≡ programme row **500** (Time central heating CH1) or **560** (Time hot water).
- **B** by one position <|≡ programme row **516 (Pre-set values)** for heating and programme row **576** for DHW.
- **B** **B** by one position until **yes** is displayed **B** to confirm.
- **C** to return to the previous menu.



*After terminating the procedure, the daily programming bar on the main menu changes. Heating is always enabled during the day. To reprogramme the boiler, repeat the procedure described in section HOURLY PROGRAMMING.*

## 18.4 CONTROL PANEL BLOCK FUNCTION

In order to safeguard the set programming from unauthorised people, block all the functions associated with button **C**.

### BLOCK procedure

- **C** **B** <|≡ **Operator unit** **B** to confirm.
- **B** <|≡ programme row **27** (Programming lock) **B** to confirm.
- **B** <|≡ **On** **B** to enable the block function.

### RELEASE procedure

- **C** **A** and **B** (hold down for approx. 6 seconds) <|≡ **Programming temporarily unlocked**".

This release phase is temporary and lasts 1 minute, after which the block resumes automatically. To permanently disable the function, perform the temporary release procedure and then **B** to **Off** at programming row **27** (Programming lock) and **B** to confirm the release.

## 19. SWITCHING OFF THE BOILER

To turn off the boiler, disconnect the electric power supply using the two-pole switch. In the "Off" operating mode the boiler stays off but the electrical circuits remain powered and the frost protection function remains active.

## 20. PROLONGED SHUTDOWN / FROST PROTECTION

Do not drain the whole system as filling up with water again could cause unnecessary and harmful scale to build up inside the boiler and the heating elements. If the boiler is not used during winter and is therefore exposed to the danger of frost, add some specific anti-freeze to the water in the system (e.g.: propylene glycol coupled with corrosion and scale inhibitors). The electronic boiler management system includes a "frost protection" function for the heating system which, when delivery temperature falls below 5°C, lights the burner until a delivery temperature of 30°C is reached.



*The function is operative if: the boiler is electrically powered, there is gas, system pressure is normal and the boiler is not blocked.*

## ENERGY-SAVING TIPS

### Adjustment in the heating mode

Adjust the boiler flow temperature depending on the kind of system. For systems with radiators, set a maximum heating water flow temperature of approximately 60°C, and increase this value if the required room temperature is not reached. For systems with radiant floor panels, do not exceed the temperature indicated by the system designer. Use the External Sensor and/or Control Panel to automatically adjust the flow temperature to atmospheric conditions or the indoor temperature. This ensures that no more heat than that effectively necessary is produced. Use room thermostats to adjust the temperature without overheating the rooms. Every extra degree centigrade means consuming approximately 6% more energy. Also room ambient temperature depending on how the rooms are used. For example, the bedroom or the least used rooms can be heated to a lower temperature. Use the programmable timer and set the night-time room temperature at approximately 5°C lower than that during the day. There is no appreciable saving to be achieved by setting it any lower. Only in case of a prolonged absence, such as a holiday, should the temperature setpoint be lowered. Do not cover radiators as this prevents the air from circulating correctly. Do not leave the windows partially open to ventilate the rooms but open them completely for a short period.

### Domestic hot water

Setting the domestic hot water at the required temperature without mixing it with cold water saves a lot of money. Additional heating wastes energy and creates additional scale. Recommended minimum storage temperature of 60°C to reduce the Legionella risk.

## 21.ACCESS TO THE PARAMETER CONFIGURATION MENUS

### KEY TO DISPLAY (see figure to side)

a	Date: day, month, year
b	Day of the week
c	Pressure in boiler / heating circuit
d	Clock: hour and minutes

To access the list of configuration menus, proceed as follows (consult the "Description of Symbols" section):

C B to select the required menu; B to confirm or C to exit without saving.

The list of configuration menus is:

- Information (INFORMATION MENU)
- Set time and date (TIME AND DATE MENU)
- Operator unit (CHANGE LANGUAGE)
- Time central heating (HOURLY PROGRAMMING)
- Time central heating CH3
- Time hot water
- Time auxiliary
- Holiday heating (HOLIDAY PROGRAMME)
- Temps / mode
- Temps / mode hot water
- Instantaneous HW heater (not used)
- Error (FAULTS)
- Diagnostics heat generation

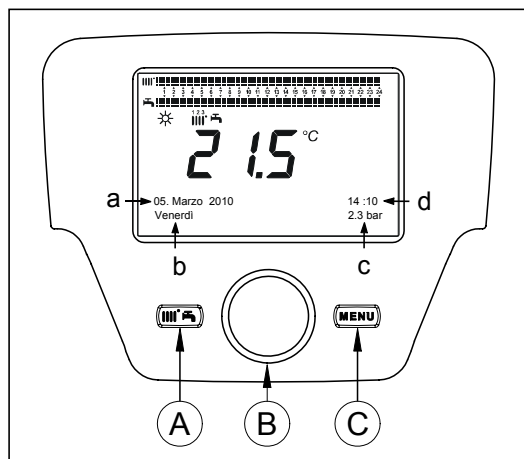

### 21.1 INFORMATION MENU



*In case a fault arises, the first data displayed is the fault code.*

To display boiler information, select "Information" as indicated in section 21.

Boiler temperature	°C	Boiler flow temperature
Outside temp	°C	Outside temp
Outside temp min	°C	Minimum memorised outside temperature value (with external probe connected)
Outside temp max	°C	Maximum memorised outside temperature value (with external probe connected)
DHW temperature	°C	DHW temperature (value read by the boiler DHW circuit probe)
Manifold temperature	°C	Instantaneous temperature of manifold sensor (with connection to solar plant)
State central heating (1,2,3)	(On/Off)	Heating circuit operating mode (circuits: 1,2,3)
State hot water	Charging	DHW circuit operating mode
State boiler	(On/Off)	Boiler operating mode
Solar state	-	Indicates if sunlight is sufficient (with connection to solar plant)
Telephone customer service	n	xxxxxxxxxx

### 21.2 TIME AND DATE MENU

To set the time and date, follow the procedure indicated in section 21 and proceed as follows:

- Access the **Set time and date menu** B 1 (Hours / minutes) B (the hour flashes)
- B to edit the hour B to confirm (the minutes flash) B to edit B to confirm.
- B to edit 2 (Day / month) and 3 (Year) performing the same procedure as above.
- C to return to the previous menu.

## 21.3 CHANGE LANGUAGE (Operator unit menu)

To set the language, follow the procedure indicated in section 21 and proceed as follows:

- access the **Operator unit menu** **B** and select programme row **20** (Change language);
- **B** to select a language **B** to save.
- **C** to return to the previous menu.

## 22. FUNCTIONS ASSOCIATED WITH THE EASY MENU BUTTON (rapid menu

Press **A** e **B** to scroll the following functions:

- Standby/operation
- Hot water boost
- Central heating mode CH1
- Room temperature CH1
- Hot water mode
- Rated DHW setpoint

then **B** to enable the selected function, **B** to modify the value and **B** to confirm.

### Standby/operation

If this function is enabled, appears on the display and boiler operation is disabled in the DHW and heating modes (the anti-freeze function remains enabled). To recover boiler operation, repeat the procedure described above.

### Hot Water boost

This function is used to heat the storage boiler, if fitted, until the set temperature is reached, regardless of the set time band.

### Central heating mode CH1

This menu is used to select the boiler operating mode as indicated in section 17.

### Room temperature CH1

Select this menu to change the comfort ambient temperature value.

### DHW mode

Select this menu to enable "On" or disable "Off" DHW. The "Eco" function disables pre-heating (only present in boilers producing domestic hot water).

### Rated DHW setpoint

Select this menu to change the maximum DHW temperature value.



When DHW is disabled, disappears from the display.



When the function of pre-heating is active, the symbol is flashing even without any D.H.W. request.

## 23. FAULTS

<b>A</b>	Main fault code (see table)
<b>B</b>	Secondary fault code
<b>C</b>	Description of fault

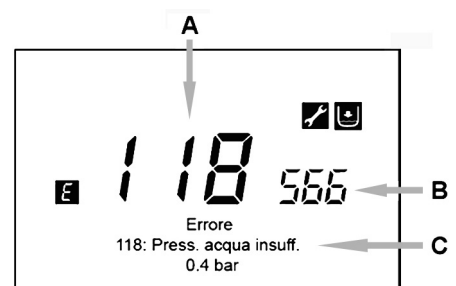

The faults shown on the display are identified with the symbol **E**, the information shown on the display is:

- A fault code (**A**)
- A secondary fault code (**B**);
- A brief description of the fault (**C**);
- The following symbols could appear on the display: the meaning of which is explained in section COMMISSIONING THE BOILER "CONTROL PANEL".

In the event of a fault, to display the main menu, **C**. The symbol **E** remains on the display indicating that the appliance is in the fault status. After a minute the display returns to visualise the fault screen as indicated in the figure.

## 23.1 RESETTING FAULTS





Faults can be reset AUTOMATICALLY, MANUALLY or by calling in the AUTHORISED TECHNICAL SERVICE CENTRE. The various modes are described in detail below:

### AUTOMATIC



If the flashing symbol  appears on the display, the fault will be automatically reset (temporary fault) as soon as the event that caused it is eliminated.

Faults of this type are often generated by elevated water flow and/or return temperatures in the boiler. They are therefore automatically reset as soon as the temperature falls below the critical value. If the same fault is repeated with a certain frequency and/or is not automatically reset by the boiler, contact the Authorised Technical Service Centre.

### MANUAL

To manually reset the fault, when the fault code appears  **B**  **B**  "Yes"  **B** to confirm. The fault code disappears after a few seconds.

### CALLING IN THE AUTHORISED TECHNICAL SERVICE CENTRE

If the symbol  appears on the display together with the symbol , contact the **AUTHORISED TECHNICAL SERVICE CENTRE**. Before calling, note down the fault code/s and the short message accompanying the fault.



If a fault code is displayed that is not included in the list or if a certain fault occurs frequently, contact the **AUTHORISED TECHNICAL SERVICE CENTRE**.

<b>E</b>	Description of fault	<b>E</b>	Description of fault
<b>10</b>	External probe sensor	<b>128</b>	No flame
<b>20</b>	NTC flow sensor	<b>130</b>	Fumes NTC tripped due to overtemperature
<b>28</b>	NTC fumes sensor	<b>133</b>	Ignition failure (4 attempts)
<b>40</b>	NTC flow sensor	<b>151</b>	Boiler board internal fault
<b>50</b>	NTC DHW sensor (only for heating-only model with storage boiler)	<b>152</b>	Generic parameter setting error
<b>52</b>	Solar DHW sensor (if connected to a solar plant)	<b>153</b>	Forced reset when the Reset button is pressed and held for more than 10 seconds (see section "FAULTS THAT CANNOT BE RESET BY THE USER")
<b>73</b>	Solar manifold sensor (if connected to a solar plant)	<b>160</b>	Fan fault
<b>83</b>	Communication problem between boiler board and control unit. Probable short circuit on wiring.	<b>162</b>	Flue pressure switch tripped (see section "FAULTS THAT CANNOT BE RESET BY THE USER")
<b>84</b>	Address conflict between control units (internal fault)	<b>321</b>	NTC domestic hot water sensor faulty
<b>98</b>	Accessory not detected or recognized (*)	<b>343</b>	Generic parameter setting error of solar plant (if connected to a solar plant)
<b>109</b>	Air in boiler circuit (temporary fault)	<b>384</b>	Abnormal light (parasite flame – internal fault)
<b>110</b>	Safety thermostat/thermal fuse/exchanger flange thermostat(**) tripped due to over temperature (pump probably blocked or air in heating circuit)	<b>385</b>	Input voltage too low
<b>111</b>	Safety thermostat tripped due to overtemperature.	<b>386</b>	Fan speed threshold not reached
<b>117</b>	Pressure in hydraulic circuit too high	<b>430</b>	No circulation safety trip (control performed via a pressure sensor)
<b>118</b>	Pressure in hydraulic circuit too low	<b>432</b>	No functional hearth or safety thermostat tripped due to over temperature (E110)
<b>125</b>	No circulation safety trip (control performed via a temperature sensor)		

(\*) After powering up the boiler (or after a Reset for lockout), the error appears on the display once the self-check is completed. The fault code is displayed permanently if the accessory is not recognized.

(\*\*) See Section "ADJUSTMENT AND SAFETY DEVICES".

## 24. FAULTS THAT CANNOT BE RESET BY THE USER

In the case of **FAULTS** that cannot be reset, for example E151 or E162 or exceeding of 5 attempts by the user to perform a manual RESET, it is necessary to RESET the board. Remove the control panel (if it is fitted in the boiler) and press the black button **R** located under the rubber cap (symbol .

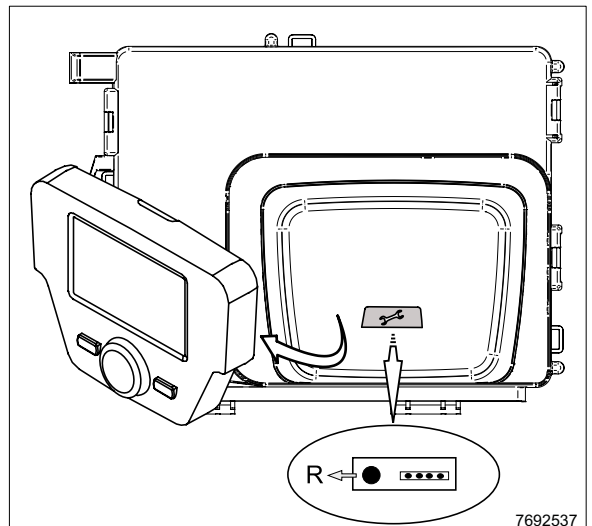

7692537

## 25. ADJUSTMENT AND SAFETY DEVICES

The boiler has been designed in full compliance with European reference standards and in particular is equipped with the following:

- **Limit thermostat**

Thanks to a sensor placed on the CH flow line, this thermostat interrupts the flow of gas to the burner if the water in the primary circuit overheats.

- **Exchanger flange thermostat (260°C)**

This device is located on the exchanger flange and interrupts the flow of gas to the burner if the front insulation yields and overheats the exchanger or the flange gasket develops a fault. Press the reset button on the thermostat and eliminate the fault.

- **Thermal fuse**

This device is located at the rear of the exchanger and interrupts the flow of gas to the burner if the rear insulation yields and overheats the exchanger. If this device cuts in, dismount the exchanger and replace the thermal fuse (see paragraph "THERMAL FUSE REPLACEMENT OF HEAT EXCHANGER").



It is forbidden to disable this safety device.

- **NTC flue sensor**

This device is positioned on the fumes duct. The electronic board stops gas from flowing to the burner in case of over heating.



The above reset operation is only possible if the temperature is less than 90°C.



It is forbidden to disable this safety device

- **Fumes pressure switch**

This device stops the flow of gas to the burner when the pressure in the flue ducts exceeds 600 Pa. Under these conditions, the boiler is blocked and only after the fault has been eliminated can the boiler be ignited again (see section "FAULTS THAT CANNOT BE RESET BY THE USER").

- **Flame ionisation detector**

The flame sensing electrode guarantees safety of operation in case of gas failure or incomplete ignition of the main burner. In these conditions, the boiler blocks.

- **Hydraulic pressure switch**

This device allows the main burner to be ignited only if system pressure is higher than 1 bar.

- **Pump post-circulation**

The electronically-controlled pump post-circulation function lasts 3 minutes and is enabled, in the heating mode, if the ambient thermostat causes the main burner to go out.

- **Antifreeze device**

The electronic boiler management system includes an "antifreeze" function for the heating and DHW systems which, when flow temperature falls below 5°C, operates the burner until a flow temperature of 30°C is reached. This function is enabled when the boiler is switched on, the gas supply is open and the system is correctly pressurised.

- **Pump anti-block function**

If no heat demand is received in the heating and/or DHW modes for 24 consecutive hours, the pumps will automatically start and operate for 10 seconds.

- **Hydraulic safety valve (heating circuit)**

This device is set to 6 bar and is used for the heating circuit. Connect the safety valve to a drain trap. Do not use it to drain the heating circuit.

- **Heating pump pre-circulation**

In case of a heat demand in the heating mode, the appliance can pre-circulate the pump before the burner is ignited. This pre-circulation phase last from a few seconds to a few minutes, depending on the operating temperature and installation conditions.

**The functions performed by the adjustment and safety devices are only operative if the boiler is switched on.**

## 26. ROUTINE MAINTENANCE INSTRUCTIONS

To keep the boiler efficient and safe, have it checked by a competent person at the end of every 12 months. Careful servicing ensures economical and safe operation of the system.

## 27. ANNUAL SERVICING

The service must be performed only by qualified and competent staff in accordance with the Gas safe, Installation and use regulations. In UK this person need to be approved by the Health and Safety Executive. To optimise boiler efficiency, carry out the following at the annual service:

- Check the appearance and airtightness of the gaskets of the gas and combustion circuits. Replace any worn seals with new original spares;
- Check the state and correct position of the ignition and flame-sensing electrodes;
- Check the state of the burner and make sure it is firmly fixed;
- Check for any impurities inside the combustion chamber. Use a vacuum cleaner to do this;
- Check the gas valve is correctly calibrated;
- Check the pressure of the heating system;
- Check the pressure of the expansion vessel (system);
- Check the fan works correctly;
- Make sure the flue and air ducts are unobstructed;
- Check for any blockages inside the siphon;
- Check correct operation of the fumes pressure switch, where present. Blow into the positive connector of the pressure switch without using electromechanical devices, until you hear the activation click.



**Before commencing any maintenance operations, make sure the boiler is disconnected from the power supply. After servicing, reset the original operating parameters of the boiler if they were changed.**

### 27.1 CLEANING THE HEAT EXCHANGER FUMES SIDE



**Before starting to clean the heat exchanger, wait until the temperature is lower than 40°C and protect all the electric components against splashes of water.**

Proceed as follows to clean the heat exchanger:

- Disconnect the boiler from the mains power supply.
- Close the gas inlet valve.
- Remove the front cover from the boiler.
- Lower the electrical box, ensuring it is protected against contact with water.
- Disconnect the cables of the ignition electrode, the flame sensing electrode, and the heat exchanger flange thermostat.
- Remove the fan-mixer-burner-flange assembly, unscrewing the 6 nuts M6 and the connector under the mixer.
- Protect the rear insulating panel (2) against water with a waterproof film, available in the cleaning kit.
- Accurately suck up the residue inside the combustion chamber and remove any scale, using a brush with plastic bristles available in the cleaning kit.
- Sprinkle the surfaces to be cleaned (1) generously with the appropriate liquid BX-HT Cleaner or similar using the appropriate spray bottle and wait 10 minutes (other products may be used, after consulting the authorised technical assistance service). Brush without rinsing and apply BX-HT Cleaner again. Let 10 more minutes pass, then brush again. If the result is not satisfactory, repeat the operation.
- When cleaning is finished, rinse with water.
- Replace the gasket of the burner support flange.
- To reassemble, proceed in the inverse order, tightening the 6 nuts of the flange with a torque of 5.5 Nm.

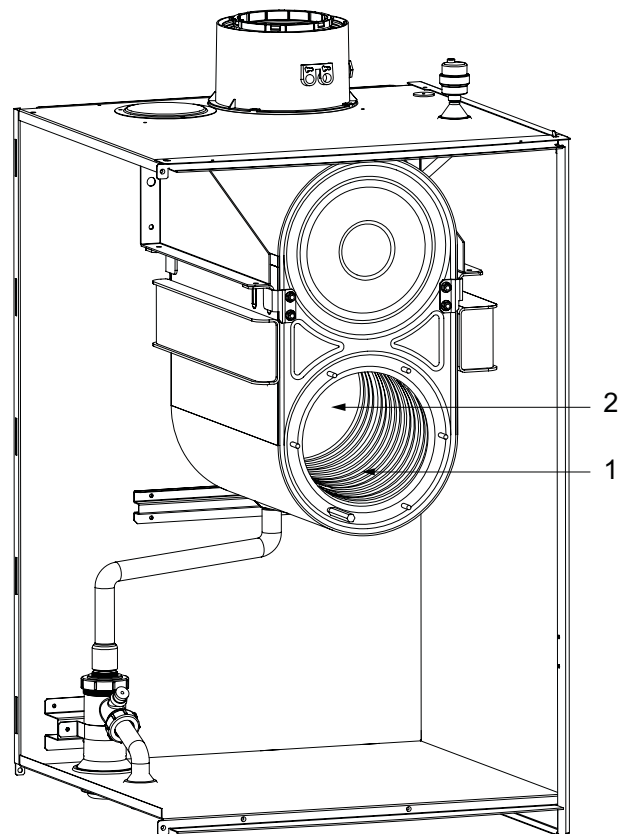



## 27.2 CHECKING THE BURNER

The burner needs no cleaning.

- Check the burner surface for damage, replace the burner if necessary.
- Check the positioning of the flame detection probe.
- Verify that the distance of the ignition electrode is within tolerance as shown in the figure.
- Check that the insulation of the burner flange it is not damaged otherwise replace it.

### POSITIONING THE ELECTRODES

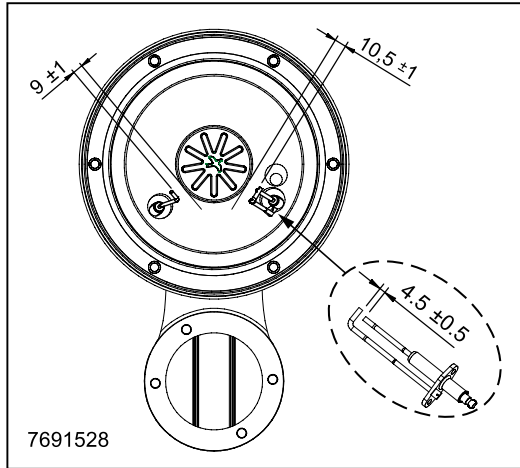

a	Flame detection probe
b	Ignition electrode
c	Burner
d	Burner surface insulation

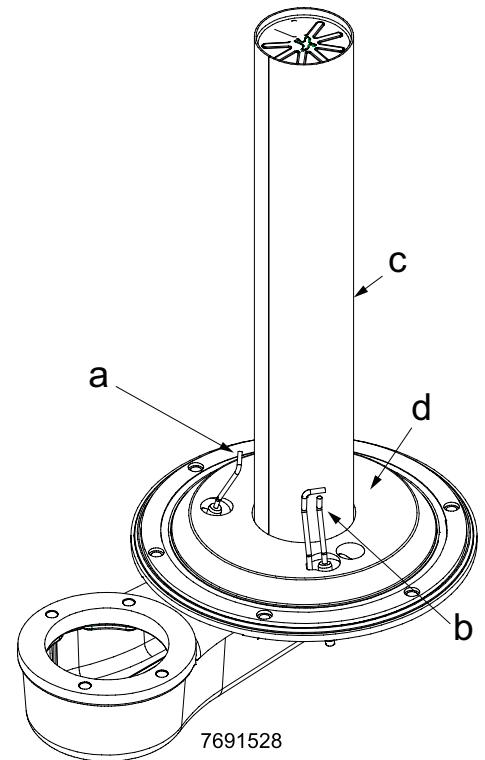

## 27.3 CLEANING THE CONDENSATE TRAP

Unscrew the lower section of the water condense trap.

- Clean the bottom of the trap by flushing it out with water.
- Fill the lower section with water until about 10 mm below the upper edge.
- Fasten the lower section onto the condense trap again.



**Do not operate the boiler with empty condense trap to avoid risk of poisoning through the gas combustions.**

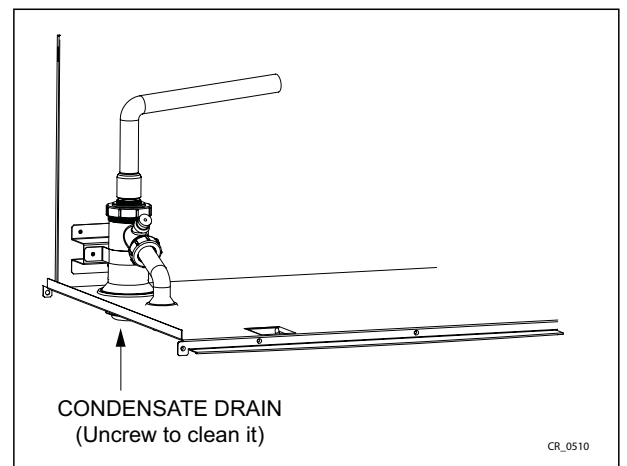

## 27.4 COMBUSTION PARAMETERS

To measure combustion efficiency and the emissions of the products of combustion, the boiler is fitted with two dedicated test points. One connection point is connected to the flue gas discharge circuit ( **A** ), and allows monitoring of the quality of the combustion products and the combustion efficiency. The other is connected to the combustion air intake circuit ( **B** ), allowing checking of any recycling of the combustion products in case of coaxial pipelines. The following parameters can be measured at the connection point on the flue gas circuit:

- temperature of the combustion products;
- oxygen ( $O_2$ ) or carbon dioxide ( $CO_2$ ) concentration;
- carbon monoxide ( $CO$ ) concentration.

The temperature of the combustion air must be measured on the test point located on the air intake flue ( **B** ) by inserting the measurement sensor by about 90 mm ( **C** ).

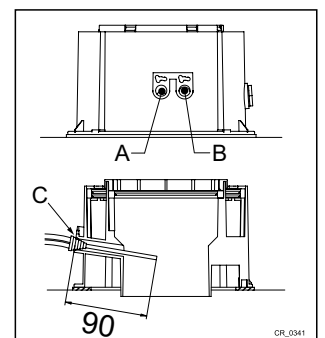

**To enable the "CHIMNEY SWEEP MODE" consult section "SPECIAL FUNCTIONS".**

## 28.THERMAL FUSE REPLACEMENT OF HEAT EXCHANGER

The thermal fuse is positioned on the rear of the heat exchanger as shown in the figure, is electrically connected in series with the safety thermostat. Its function is to protect the exchanger from overheating in case of insulation failure. When this occurs the device appears on the display the anomaly **E110**. If the cause is due to the rupture of the insulation it is necessary to remove the heat exchanger and replace the rear insulation and the thermal fuse.

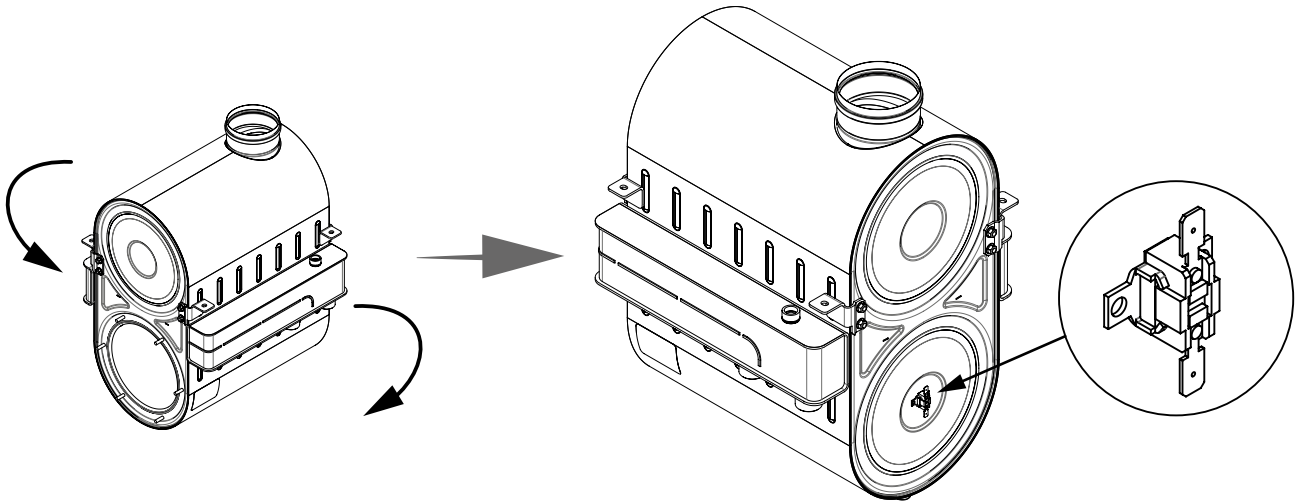

## 29.DISMANTLING, DISPOSAL AND RECYCLING



Only qualified technicians are authorised to service the device and system.

Before dismantling the appliance, be sure to disconnect the power supply, close the gas inlet shutoff valve and secure all of the boiler and system connections.

Dispose of the appliance correctly according to the laws and regulations in place. The appliance and accessories cannot be discarded along with normal household waste.

More than 90% of the materials that make up the appliance are recyclable.

# 30. DIAGRAMS

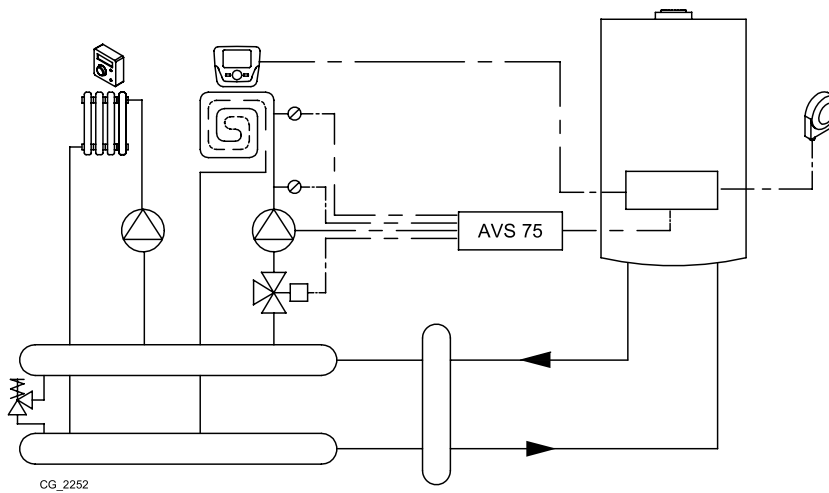
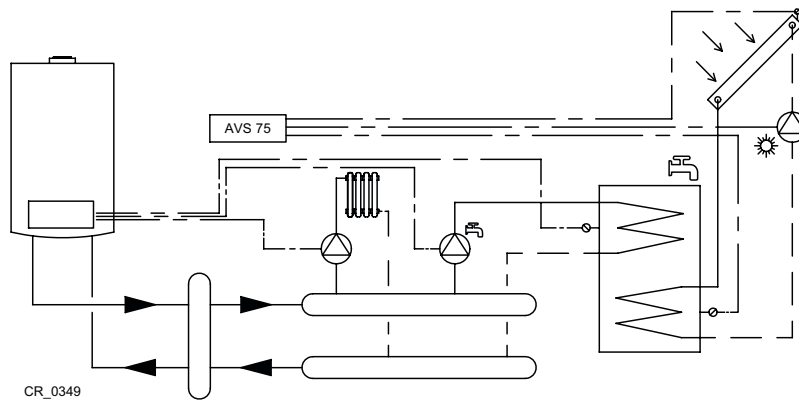
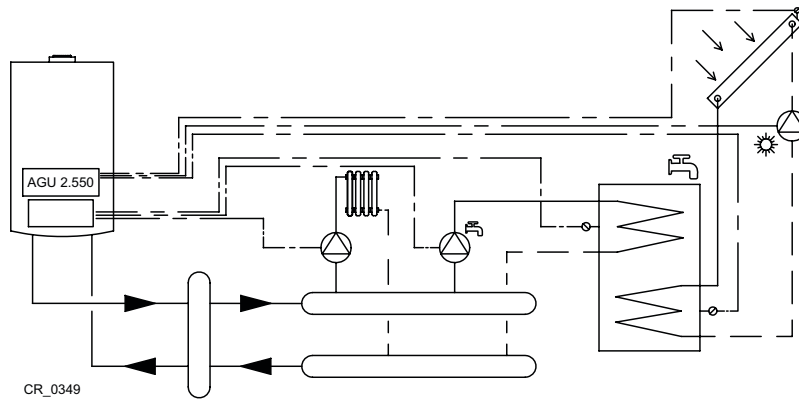
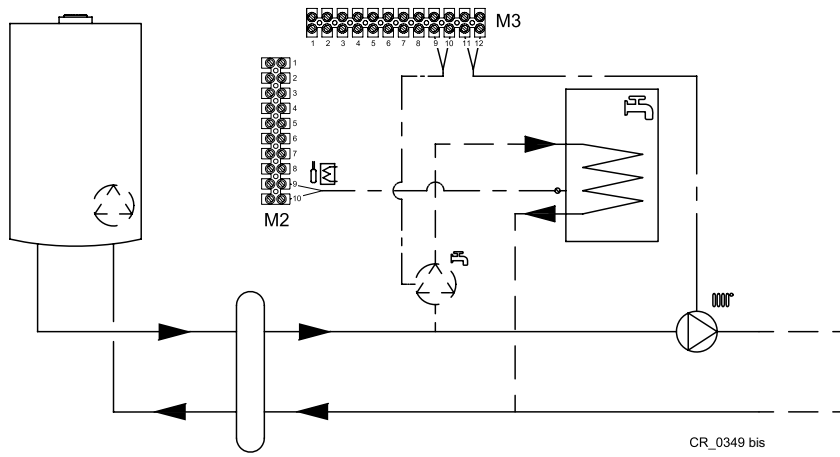

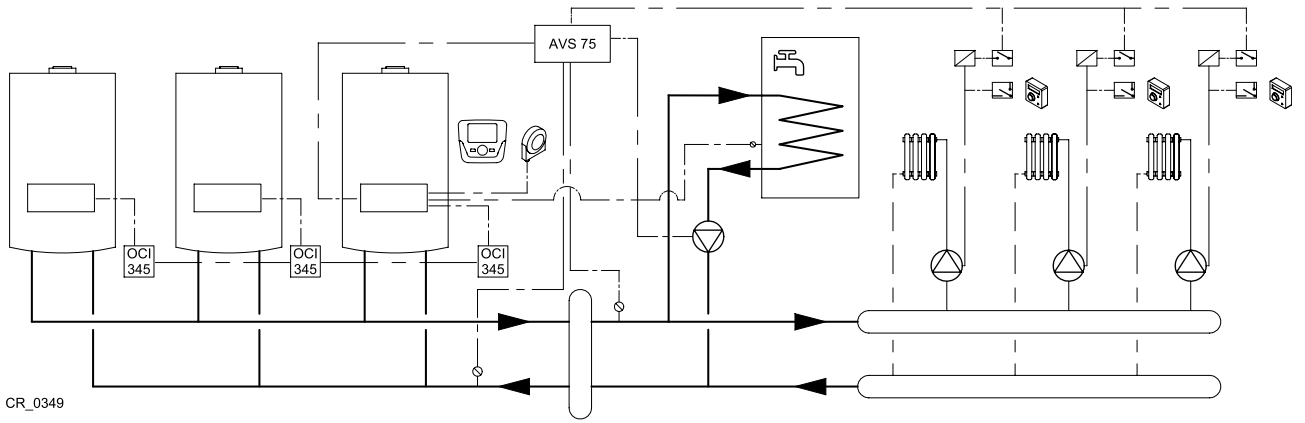

CR\_0349

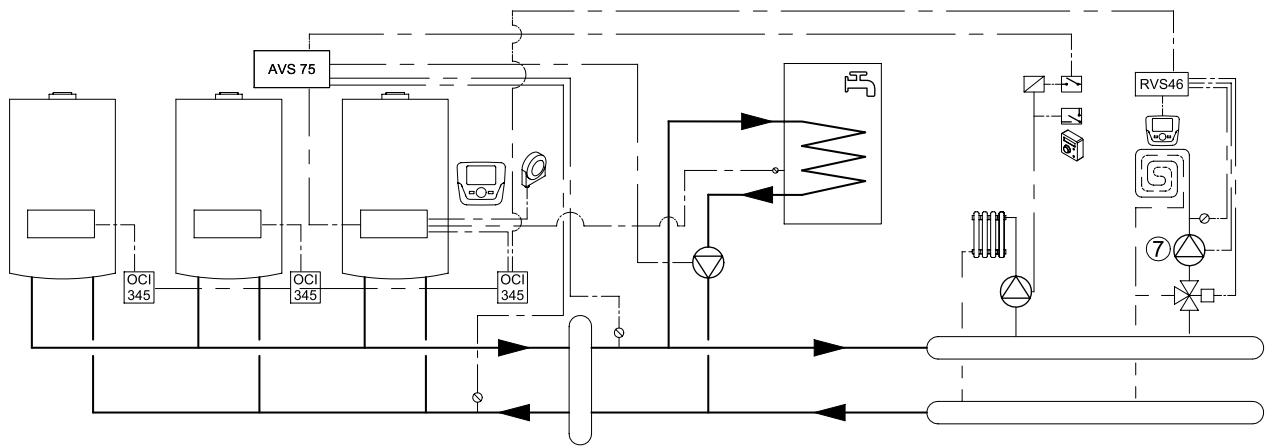

CR\_0349

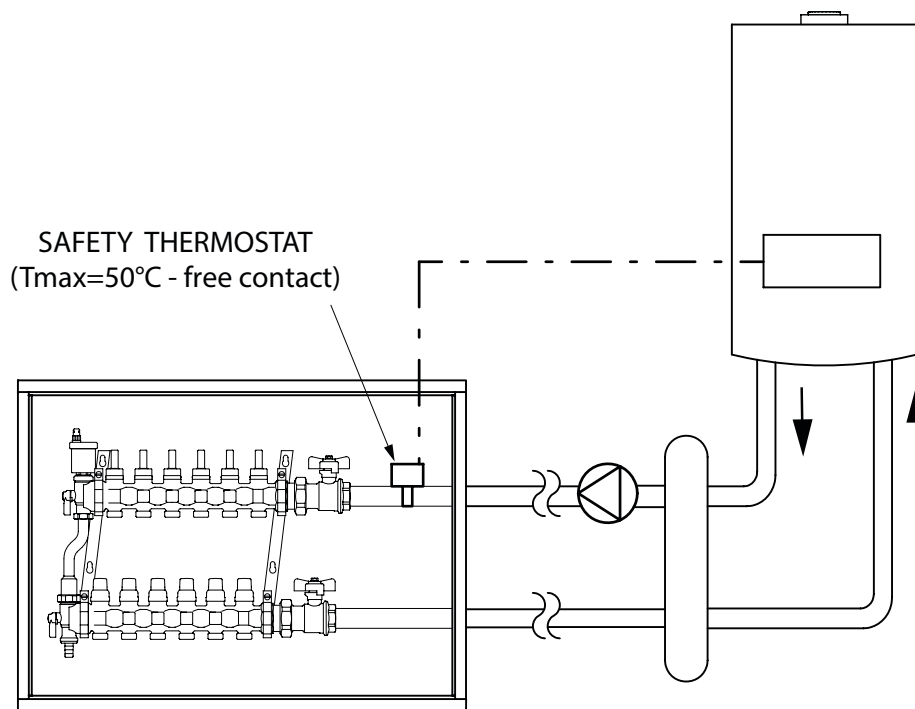

CG\_2482

### MODIFIED PARAMETERS

Nr	VALUE	NOTE





**Potterton Commercial**  
Brooks House  
Coventry Road  
Warwick  
CV34 4LL

Service:

Tel 0345 070 1058  
Fax 0345 070 1074

Technical:

Tel 0345 070 1057  
Fax 0345 070 1059



Email: [commercial.service@baxiheating.co.uk](mailto:commercial.service@baxiheating.co.uk)  
[www.baxiheating.co.uk](http://www.baxiheating.co.uk)



Authorised User No. 00264



RS 33961

**POTTERTON**  
COMMERCIAL